

# **VERTIFLO**

---

**Series 624-628  
SHORT SETTING  
INDUSTRIAL VERTICAL  
PROCESS PUMP**

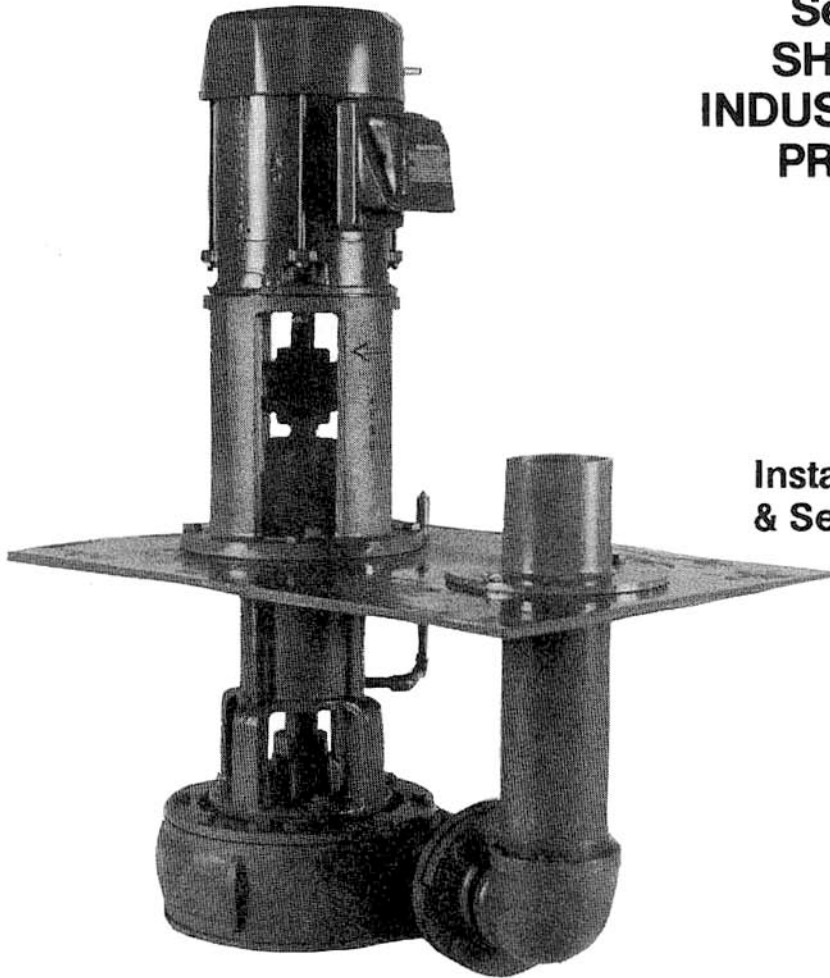

**Installation, Operation  
& Service Instructions**

---

## **IMPORTANT Handling Instructions**

Lifting equipment should be attached to motor support bracket or cover plate.

---

## I. INSTALLATION INSTRUCTIONS

**Vertiflo** Pump Division's short setting vertical process pumps, Series 624/628 are completely assembled, carefully adjusted and pre-lubricated at the factory before shipment.

### Important

**Series 624/628 pumps are constructed with the radial bearing below the support plate. Do not allow the high liquid level of the fluid being pumped to reach the radial bearing. Compliance to this statement will allow for longer pump life.**

A. Carefully lower the pump into position. The support plate (20) must be level and rest evenly at all points of contact where it will be located. (See pump cutaway-Figure 1.)

B. Turn pump shaft by hand to make sure that it rotates freely — after installation. If there is binding in the rotation, check the following:

1. Separate the pump half coupling (12B) from motor half coupling to determine if binding is in motor. If binding has not been corrected, see impeller adjustment section.
2. Connect the system piping to the pump discharge (38) being very careful that no stresses or piping loads are placed on the pump. A check valve and gate valve should be installed and properly supported at pump discharge to prevent fluid back-flow and reverse pump rotation.
3. Connect power lines to motor leads as shown on the motor wiring diagram for specific line voltage used. Follow all state and local wiring codes.
4. Check and be sure starter overload protection is proper for specific voltage used and for the amperage rating.
5. Jog motor starter quickly to check for proper rotation. Shaft rotation is clockwise when looking down on the motor. There is also a rotation arrow on the motor support.  
(1). If pump rotation is wrong, contact a qualified electrician to make necessary corrections. After correct rotation is obtained, connect the pump coupling.
6. Close gate valve and start pump. Open valve slowly to obtain desired capacity. Pump should now operate smoothly. If vibration occurs, check for pipe stress.

NOTE: Pipe stress cannot be tolerated by pumps. Pipes must be sufficiently supported by other means.

## II. LUBRICATION

All **Vertiflo** standard vertical short setting process pumps are properly lubricated at the factory. Further on-site lubrication schedules depend upon local operating conditions. It is recommended that all bearings be periodically inspected and greased.

- A. Thrust bearing (8) and radial bearing (12) should be greased every two or three months.
- B. A lithium base grease with corrosion inhibiting properties should be used.
- C. Motor should be lubricated in accordance with the manufacturer's recommendations.

## III. DESIGN

The 624/628 power frame consists of three basic parts. (1) The main cast iron bearing frame. The bearing bores are machined for a slip fit of both bearings. (2) Shaft is sized to allow both bearings to slide freely over shaft. (3) Bearings; supplied with cam locking collars, which, when in place on shaft can be locked and set-screwed to form an extremely rigid mating of shaft and bearing. The radial, or lower bearing, has the smaller O.D. and is preset and locked to the shaft before assembly of frame. The radial bearing is thus allowed to float freely in the bearing bore of the frame with the shaft during impeller adjustment. The thrust or top bearing is placed over the shaft before assembly, but not locked to the shaft. The thrust bearing must be firmly seated in the frame. Adjustment is accomplished by a threaded nut above the bearing. Turning the threaded nut raises or lowers the shaft, radial bearing, and impeller assembly thru the top thrust bearing bore to the proper position. The shaft is then locked into position with the thrust bearing lock collar.

## IV. IMPELLER ADJUSTMENT

1. Adjust impeller running clearance by first removing capscrews (7) holding thrust bearing cap (4) in place. Bend down metal locking tab on bearing lock washer (6) and turn locknut (5) counter-clockwise several turns. Loosen the set screw in the thrust bearing collar (8), then using drive pin in collar hole, strike the collar in the opposite direction of the normal shaft rotation, thus releasing the cam of the bearing with the cam of the bearing inner ring. Tap top of lock collar to seat bearing. Then gently tap the top of the pump shaft (22) to lower the rotating element and impeller to the face of the suction head (35).
2. To readjust, tighten bearing locknut (5) until shaft (22) just turns freely by hand. Turn nut  $\frac{1}{2}$  additional turn. With drift pin in hole of thrust bearing collar, strike in direction of shaft rotation to lock. Tighten set screw. Re-tighten lock nut if required and bend tang of lock washer (6) into slot of nut.
3. Turn shaft again by hand, making certain shaft and impeller turn freely. If shaft binds or impeller rubs, raise impeller an additional  $\frac{1}{4}$  turn. The correct clearance between the impeller and suction face is .020-.030, normally  $\frac{1}{2}$  turn of locknut (5).
4. Replace bearing cap.

## V. LIQUID END INSPECTION

(See Figure 1.)

NOTE: Before dis-assembly, match-mark parts for ease in re-assembly.

1. Disconnect wiring from motor. Close discharge gate valve and disconnect pump discharge pipe. Remove foundation bolts in the support plate (20) and lift pump and support plate (still assembled) from the tank and place horizontally on floor.
2. Remove pump discharge flange bolts (42).
3. Remove top case adaptor bolts (19) and remove casing and suction head as one piece.
4. To remove impeller, straighten cotten pin (21B) and back out of castellated impeller nut (21A). Unscrew impeller nut (21) by turning counter-clockwise while holding coupling (3) with a strap-type wrench. Remove impeller washer (21D).
5. To remove impeller from shaft, use three fully threaded cap screws  $\frac{1}{2}$ "-13NC x 2- $\frac{1}{2}$ " long as jackscrews in the threaded holes in the impeller shroud. The capscrews will tighten against the throttle housing, forcing the impeller off the shaft. Remove the impeller key (21C) from its slot in shaft. Remove (4)- $\frac{1}{2}$ " capscrews (18) holding case adaptor and throttle bearing housing. Remove adaptor (34), housing gasket (17) and throttle housing (16). Check housing I.D. bore for wear and replace if necessary.
6. Loosen setscrews and remove slinger (15) from the shaft.

## VI. INSPECT OR REPLACE BALL BEARINGS AND SEAL

(Follow liquid end inspection directions, then)

1. Remove the motor.
2. Remove bearing cap (4).
3. With a block of wood over threaded end of shaft, or rubber hammer, carefully strike shaft to push shaft and thrust bearing out of bearing frame. Once top thrust bearing has cleared frame, shaft with bearings can be pulled by hand from frame.
4. To remove bearing locknut (5) bend down metal locking tabs on bearing lock washer (6) and turn nut (5) counter-clockwise. Lift off bearing lock washer (6).
5. To remove ball bearing assemblies (8) thrust and (12) radial from shaft, loosen the set screw in the bearing collar and turn the collar in the opposite direction of the normal shaft rotation. File shaft smooth at set screw mark. Pull the bearing from the shaft. Remove grease retainer (15A) from shaft (if shaft or grease retainer is to be replaced). Loosen the screw and slide retainer from shaft.
6. When installing new bearings, seal (14) should also be replaced. Remove bottom lip seal.

## VII. REASSEMBLE BALL BEARINGS AND SEAL

NOTE: Inspect frame bearing bore at bearing area for any evidence of bearing rotation and wear. If wear is present, replace frame.

1. Press seal (13) into support head with spring side of seal being visible and facing towards liquid end. Apply sufficient grease to top of seal to fill space below the radial ball bearing (12).
2. Slide bottom radial bearing (12) on the shaft (cam up) and with lower edge of inner race in-line with score mark on shaft. Lock bearing on shaft by turning collar in direction of rotation until engaged. With drift pin in collar hole, strike in direction of rotation to lock. Tighten set screw in collar.
3. Slide the grease retainer (15A) onto the shaft until the lower edge of the retainer is in line with the score mark. Replace screw and securely lock grease retainer on the shaft.
4. Slide thrust bearing (with shield) (8) and collar on the shaft, but do not lock on shaft.
5. Place the bearing lock washer (6), with inner tab in shaft keyway, and bearing lock nut (5) on the shaft — but do not lock.
6. Insert shaft into support head (23) from motor end, threaded end first. Be careful not to damage seal (10) when inserting shaft. Make sure bearing is seated. Carefully press bearing shield into support head until flush.

## VIII. ASSEMBLY OF LIQUID END

1. Slide slinger (15) over shaft, but do not tighten.
2. Place throttle housing (16) over end of the shaft and against flange of support head (10).
3. Place throttle housing gasket (17) on top of casing adaptor (34) and replace throttle housing cap screws (18) and tighten.
4. Replace impeller key (21C) in shaft and slide impeller (33) on the shaft, lining up keyway and key.
5. Replace impeller washer (21D) and castellated nut (21A) on shaft and tighten. Insert cotter pin (21B) through castellated nut (21) and drilled hole in shaft thread and bend back.
6. Place gasket (36) on case adaptor, and replace case (32). Tighten top bolts (19) and flange bolts (42).
7. If pump has separate suction head, place casing gasket (36) on suction head (35), lining up holes. Tighten suction head bolts (19).
8. Turn pump shaft by hand to check for free rotation.
9. Tighten slinger to shaft just above and clearing throttle housing.
10. Refer to Installations Instructions for details on final impeller adjustment.

ITEM	DESCRIPTION
1	MOTOR SUPPORT
1A	MOTOR ADAPTOR
2	CAPSCREW
2A	CAPSCREW
3	COUPLING ASSEMBLY
4	CAP
5	BEARING LOCK NUT
6	BEARING LOCK WASHER
7	CAPSCREW
7A	FLAT WASHER
8	THRUST BEARING
9	GREASE FITTING
10	SUPPORT HEAD
11	LUBE LINE ASSEMBLY
12	RADIAL BEARING
14	LIP SEAL
15	SLINGER
15A	GREASE RETAINER
16	THROTTLE HOUSING
17	HOUSING GASKET
18	CAPSCREW
19	CAPSCREW
20	SUPPORT PLATE
21A	IMPELLER NUT
21B	COTTER PIN
21	IMPELLER KEY
21D	IMPELLER WASHER
22	SHAFT
32	CASING
33	IMPELLER
34	CASE ADAPTOR
35	SUCTION HEAD
36	CASE GASKET
37	DISC. ELBOW ASSEMBLY
38	DISC. PIPE
39	BACK-UP RING
40	DISC. FLANGE
41	CASE FLANGE GASKET
42	CAPSCREW
42A	LOCK WASHER
42B	HEX NUT

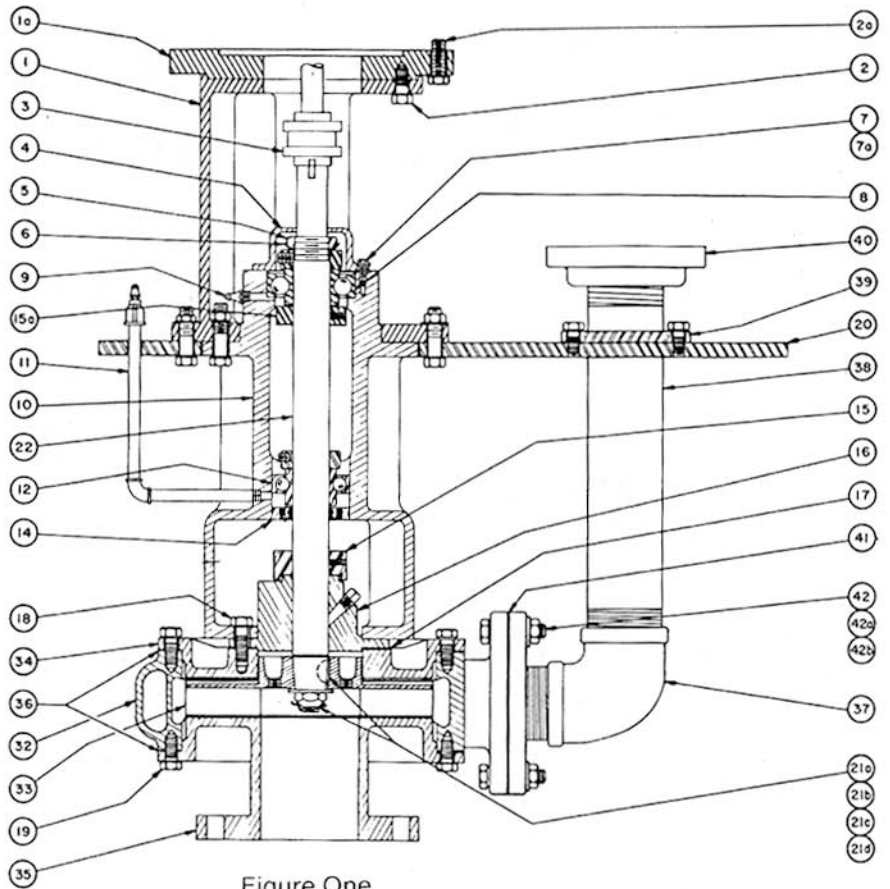

Figure One

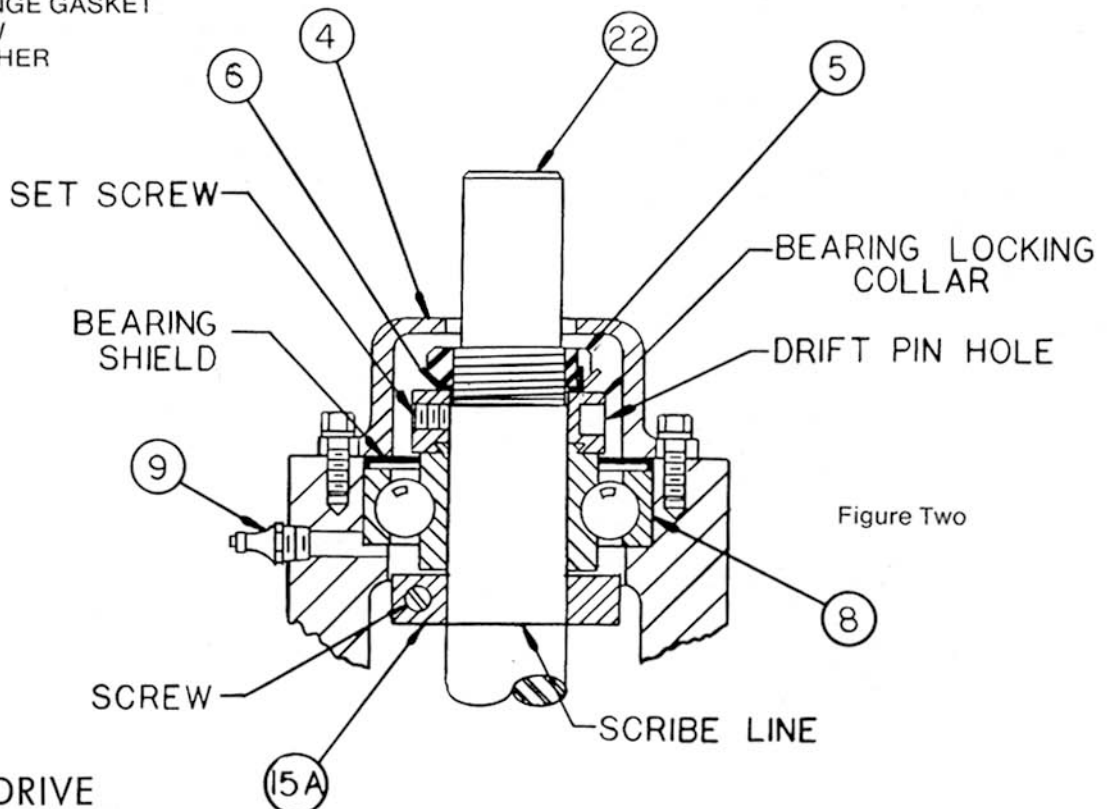

Figure Two