



T51 • E51 • M51 Series Regenerative Turbine Pumps



- Capacities to 40 GPM (120 LPM)
- Heads to 700 Feet (213 Meters)
- Temperatures to 250°F (120°C)



*Manufacturing MTH Pumps
in the USA since 1965*



MTH PUMPS
www.MTHPumps.com

T51 • E51 • M51 Series Regenerative Turbine Pumps

MTH T51•E51• M51 Series

Close-coupled and pedestal mounted regenerative turbine pumps represent the most economical, high performance alternative for low flow (2 to 40 GPM) clean fluid applications involving moderate to high pressures (heads to 700 feet). By combining the latest concepts in regenerative turbine pump design with precision computer controlled manufacturing, the T51 • E51 • M51 Series pumps deliver high efficiency operation, even at low NPSH. Costs are controlled by efficient manufacturing processes and highly optimized pump designs. Maintenance costs are kept to a minimum by combining an easily serviceable design with the use of high quality components to provide long life.

Water Passage Design

MTH masters one of the most critical design considerations for regenerative turbine pumps -- the shaping of water passageways to achieve highest capacity and pressure while minimizing horsepower requirements. By optimizing water passageway cross-sectional profiles for each impeller, MTH has improved both efficiency and pressure in the T51 • E51 • M51 Series, and exceeds the levels realized by previous techniques.

Impeller Profile

One of the most notable improvements in regenerative turbine

pump technology incorporated in T51 • E51 • M51 Series pumps involves the ability to determine the optimum impeller width and blade length. These factors have a significant effect on the required horsepower versus pressure curve for regenerative turbine pumps. By optimizing these for each T51 • E51 • M51 Series pump, peak efficiency is improved and “off peak” horsepower requirements are reduced as well.

Impeller Blades

After the most favorable impeller profile has been determined for a particular water passageway cross-section, MTH calculates the number of blades needed to maximize the performance of that pump. Current blade design in T51 • E51 • M51 Series pumps increases both efficiency and design pressure without the manufacturing difficulties associated with producing contoured blade impellers. State-of-the-art computer controlled machines simplify manufacturing of the various MTH impellers utilized in the T51 • E51 • M51 Series. The result is a high performance pump providing efficiency characteristics exceeding those of more expensive units.

NPSH Requirements

T51 • E51 • M51 Series regenerative turbine pumps meet low net positive suction head (NPSH) requirements without efficiency loss. This is achieved by keeping

the inlet fluid velocity low and then gently accelerating to passageway velocities. Special ramps are responsible for an almost shock-less fluid entry into the impeller blades and account for the high inlet efficiency of the T51 • E51 • M51 Series.

E51 Series

Similar to the T31 Series, the E51 takes advantage of our custom manufactured dual face D3 motors that incorporate a 304 stainless steel shaft and a heavy-duty bearing. The stainless steel shaft eliminates the necessity of a shaft sleeve, thereby reducing the parts count and simplifying maintenance and servicing procedures. All D3 motors feature a two-pole 50/60Hz rating, as well as CE Mark approval useful for OEM's with worldwide customers. The three-phase versions of the D3 motors feature a compact TEFC enclosure and a power output from 1/3 to 3HP. The single phase D3 motors have an ODP enclosure and a power range from 1/3 to 2HP. The E51 is available in horizontal close-coupled and vertical flange mounted configurations only. For other configurations, see the T51 Series. Please see **Design Features** for more detailed information on T51, E51 and M51 motor options.

STANDARD MATERIALS

PART	BRONZE FITTED	ALL IRON	ALL BRONZE	316 STAINLESS STEEL
Motor Bracket	Cast Iron ASTM A48	Cast Iron ASTM A48	Brass Alloy	Stainless Steel AISI 316
Cover	Cast Iron ASTM A48	Cast Iron ASTM A48	Brass Alloy	Stainless Steel AISI 316
Impeller	Brass Alloy	Carbon Steel 12L14	Brass Alloy	Stainless Steel Waukesha 88
¹ Sleeve/Bushing	Brass Alloy	Stainless Steel AISI 316	Brass Alloy	Stainless Steel AISI 316
² Shaft	Stainless Steel AISI 304	Stainless Steel AISI 304	Stainless Steel AISI 304	Stainless Steel AISI 304
“O” Rings	Buna N	Buna N	Buna N	Viton A
Seals	Buna/Carbon	Buna/Carbon	Buna/Carbon	Viton/Carbon
Seats	Buna/Ceramic	Buna/Ni-Resist	Buna/Ceramic	Viton/Ceramic

¹T51 • M51 Only: Sleeves for 3HP and under; Bushings for 5HP and over.

²E51 Only: See **Shaft Sleeves** under **Design Features** for T51 Shaft information.

LIMITATIONS

Discharge Pressure	300 PSI (20.6 Bar)
Seal Pressure*	200 PSI (13.8 Bar)
Suction Pressure (Min)	26" (880 mbar) Hg. Vac.
Speed** (Max.)	5500 RPM

Temperature

Standard Construction	-20° F (-29° C)
Ceramic Seal Seat - Water	+230° F (+110° C)
Ni-Resist Seal Seat - Water	+230° F (+110° C)
Silicon Carbide Seal Seat & Internal Seal Flush	+250° F (+121° C)

Horsepower

C3 - P3 - D3	1/3 ~ 3 HP (25-2.23kW)
C15 - P15	5 ~ 15 HP (3.7-11kW)

* Suction Pressure Plus 50 Percent of Differential Pressure

** With variable frequency drive @ 90Hz

Design Features

MTH T51, E51, and M51 Series pumps utilize the same major components, and are identical in performance, but utilize different motors. E51 pumps are restricted to close-coupled operation on our own custom designed D3 motors. The D3 motors have a dual C-face with two pole 50/60 Hz ratings as well as an upgraded heavy-duty bearing for extended service life. The three-phase motors have a TEFC IP55 enclosure and power capability from 1/3HP thru 3HP, while the single-phase motors have an ODP IP21 enclosure and range from 1/3HP to 2HP. All D3 motors feature a 304 stainless steel shaft and CE mark approval. T51 and M51 pumps can accept most commonly available motors through the use of close or flexible coupling. For wider fluid compatibility, T51 and M51 units 3HP and under feature a protective motor shaft sleeve, while motors 5HP and over utilize a corrosion resistant 316 stainless steel shaft. Motors for the T51 and M51 Series come in ODP, TEFC, and Explosion-proof enclosures and allow operation at two pole or four pole speeds (3450/2880 or 1750/1450 RPM) ranging from 1/3HP to 3HP (C3/P3 single or three phase) and 5HP to 15HP (C15/P15 three phase only).

Steep Operating Characteristics

Near-constant capacity is maintained over wide variations in pressure. High shut-off pressure overcomes temporary line resistance.

Self-Adjusting Impeller

A hydrodynamic film on each side of the impeller positions it for long life. The impeller exerts no thrust load on bearings. Pump operates equally well in a vertical or horizontal position.

Optional Features

CONSTRUCTION MATERIALS

Bronze fitted, all iron, all bronze and 316 stainless steel are available as stock materials. Consult the factory for special materials.

BEARING PEDESTALS. All T51 models can be pedestal mounted for flexible drive.

VERTICAL FLANGE MOUNT. All sizes are available as vertical mount

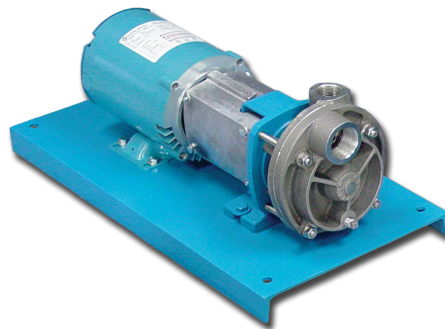

Mechanical Seals

Bronze fitted pumps have Buna N elastomers, high temperature carbon, and ceramic seats for best hot water service. Optional seats and materials are also available.

300# Case Working Pressure

Rigid structure is designed for maximum casing strength.

100% Tested

Every pump is fully tested to verify performance prior to shipment.

Volatile Fluid Handling.

Turbine impeller handles vapors in excess of 20% by volume, minimizing the possibility of vapor locks.

”O”Ring Gaskets

“O”ring seals are used throughout the T51 • E51 • M51 Series pumps to assure sealing and ease of service.

Shaft Sleeve

T51 • M51 pumps with motors 3HP and under utilize a protective shaft sleeve of an appropriate metallurgy according to the **Standard Materials** table. Motors 5HP and over have a 316 stainless steel shaft with an impeller bushing as listed under **Standard Materials**. E51 pumps do not utilize a shaft sleeve due to the use of a standard 304 stainless steel motor shaft.

units, with eight standard flange types available.

VERTICAL CLOSE COUPLED MOUNT. All sizes are available as vertical close coupled units.

INTERNAL FLUSH LINE. Internal passageway flushes mechanical seal seats. When used with the optional silicon carbide seal seat, allows operation in water up to 250°F.

Water Flinger

A water flinger provides added protection to ball bearings in the event of seal leakage.

Simple Construction

T51 • E51 • M51 Series pumps contain only three major components, allowing for easy service.

End Suction • Top Discharge

T51 • E51 Series pumps fit into small spaces easily. Discharge can be rotated in 90 degree, 180 degree and 270 degree positions.

Best Efficiency

New pump design optimizes efficiency for each size.

Non-Cavitating

T51 • E51 • M51 Series pumps may be operated under adverse inlet conditions without audible or measurable cavitation.

Low NPSH

New inlet design provides superior fluid handling ability at low head inlet conditions.

INLET STRAINER. A 90° suction strainer with a replaceable screen is available for installation in the suction line to help prevent foreign materials from entering the pump. A cap at the bottom of the strainer can be easily and quickly removed for screen cleaning or replacement.

SEALLESS CANNED VERSION

For difficult to seal applications. See the Sealless ST51 Brochure.

Horizontal Close Coupled

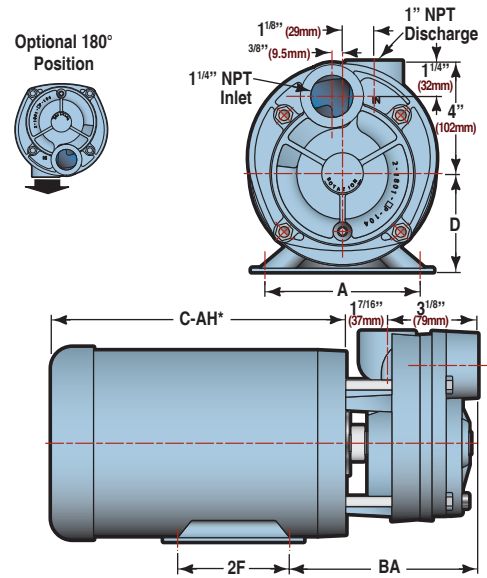
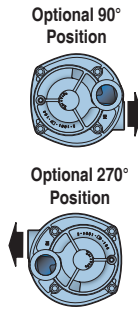
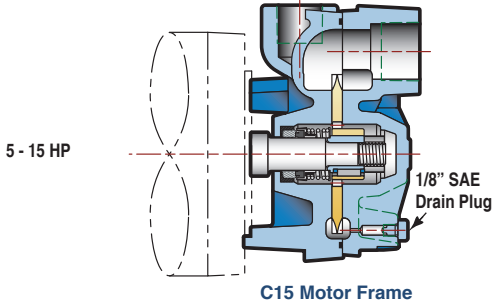
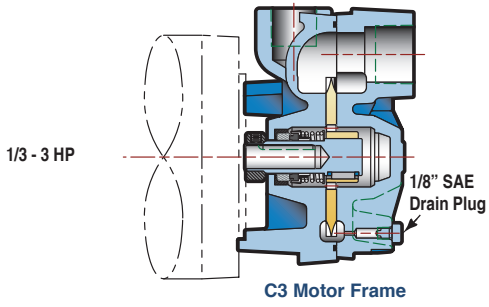

FRAME	A	D	BA	2F
56C	4 7/8 (124mm)	3 1/2 (89mm)	7 7/16 (189mm)	3 (76mm)
143TCZ	5 1/2 (140mm)	3 1/2 (89mm)	7 3/4 (197mm)	4 (102mm)
145TCZ	5 1/2 (140mm)	3 1/2 (89mm)	7 3/4 (197mm)	5 (127mm)
182TCZ	7 1/2 (191mm)	4 1/2 (114mm)	8 7/16 (214mm)	4 1/2 (114mm)
184TCZ	7 1/2 (191mm)	4 1/2 (114mm)	8 7/16 (214mm)	5 1/2 (140mm)

*See Motor Price Sheet for C-AH dimension

Vertical Flange Mounted

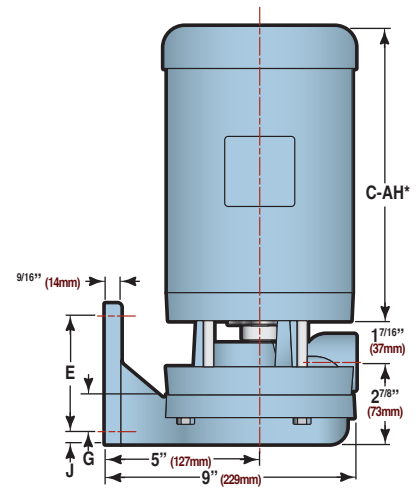
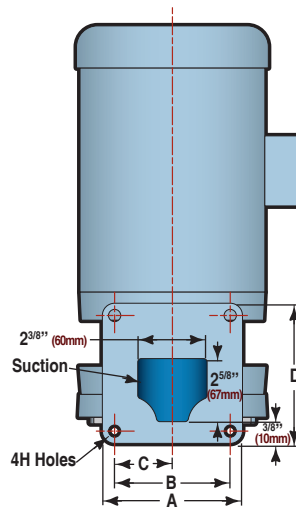
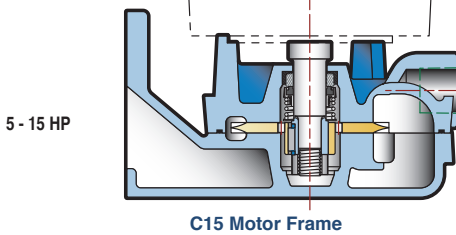
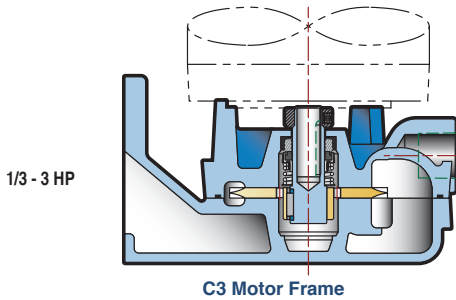

FLANGE STYLE	A	B	C	D	E	G	H	J
AU (7 1/2 x 4 1/2)	7 1/2 (191mm)	6 1/4 (159mm)	3 1/8 (79mm)	4 1/2 (114mm)	3 1/4 (83mm)	1 1/8 (29mm)	9/16 (14mm)	5/8 (16mm)
DB (4 1/2 x 4 1/2)	4 1/2 (114mm)	3.270 (83mm)	1.635 (42mm)	4 1/2 (114mm)	3.270 (83mm)	1.135 (29mm)	1/2 (13mm)	.615 (16mm)
FE (7 3/4 x 4 3/4)	7 1/2 (191mm)	6 1/4 (159mm)	3 1/8 (79mm)	4 1/2 (114mm)	3 1/2 (89mm)	1 1/4 (32mm)	9/16 (14mm)	1/2 (13mm)
PA (6 1/2 x 3 3/4)	6 1/2 (165mm)	5 1/2 (140mm)	2 3/4 (70mm)	3 3/4 (95mm)	2 5/8 (67mm)	1 1/8 (29mm)	9/16 (14mm)	5/8 (16mm)
SH & BU (6 1/4 x 4)	6 1/4 (159mm)	5 (127mm)	2 1/2 (64mm)	4 (102mm)	2 3/4 (70mm)	1 1/8 (29mm)	9/16 (14mm)	5/8 (16mm)
SK (6 1/8 x 4 1/8)	6.13 (156mm)	4.94 (125mm)	2.47 (63mm)	4.13 (105mm)	2.69 (68mm)	1.03 (26mm)	9/16 (14mm)	.72 (18mm)
ST (5 x 5)	5 (127mm)	3 3/4 (95mm)	1 7/8 (48mm)	5 (127mm)	3 3/4 (95mm)	1 1/8 (29mm)	1/2 (13mm)	5/8 (16mm)
WI (5 x 5)	5 (127mm)	4 1/8 (105mm)	2 1/16 (53mm)	5 (127mm)	4 1/8 (105mm)	1 5/16 (33mm)	7/16 (11mm)	7/16 (11mm)

*See Motor Price Sheet for C-AH dimension
All Dimensions in inches (millimeters)

Horizontal Close Coupled

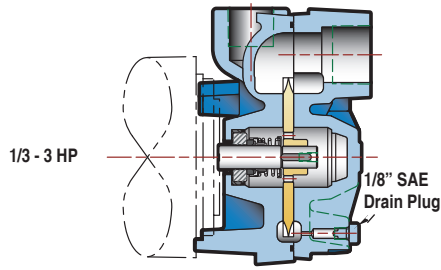

D3 Motor Frame

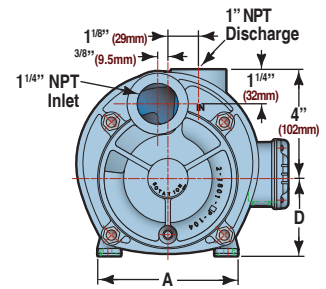
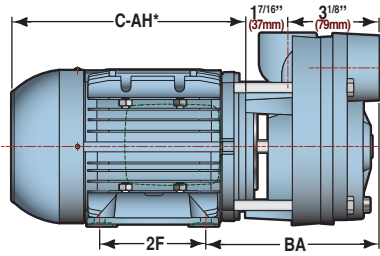
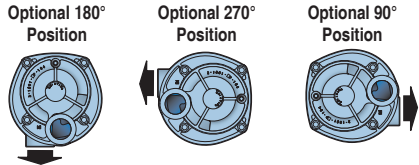

	HP	FRAME	A	D	BA	2F
E51 3φ	1/3 to 1	71	5 1/4 (133mm)	2 13/16 (71mm)	6 9/16 (167mm)	3 9/16 (90mm)
	1 1/2 to 2	80	6 1/8 (156mm)	3 1/8 (79mm)	6 3/4 (171mm)	3 15/16 (100mm)
	3	90	6 11/16 (170mm)	3 9/16 (90mm)	7 1/16 (179mm)	4 15/16 (125mm)
E51 1φ	1/3 to 1 1/2	48	4 1/4 (108mm)	3 (76mm)	7 1/4 (184mm)	2 3/4 (70mm)
	2	56	4 7/8 (124mm)	3 1/2 (89mm)	7 7/16 (189mm)	3 (76mm)

*See Motor Price Sheet for C-AH dimension

Vertical Flange Mounted

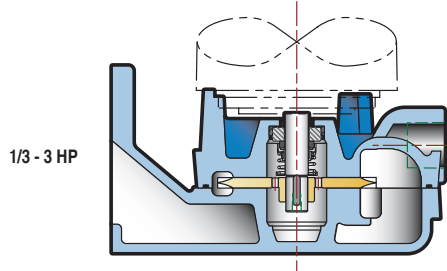

D3 Motor Frame

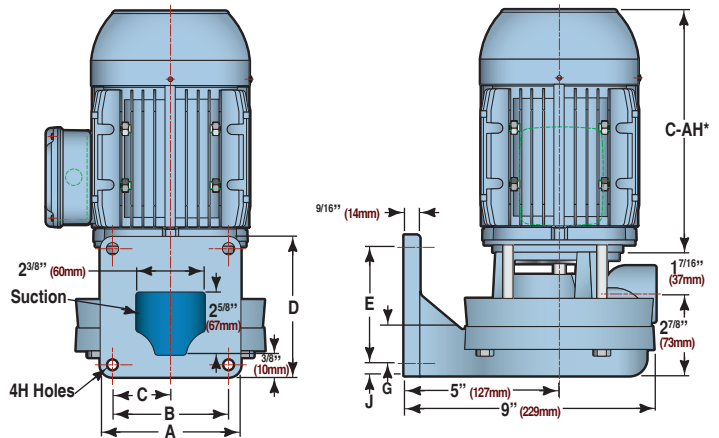

FLANGE STYLE	A	B	C	D	E	G	H	J
AU (7 1/2 x 4 1/2)	7 1/2 (191mm)	6 1/4 (159mm)	3 1/8 (79mm)	4 1/2 (114mm)	3 1/4 (83mm)	1 1/8 (29mm)	9/16 (14mm)	5/8 (16mm)
DB (4 1/2 x 4 1/2)	4.5 (114mm)	3.270 (83mm)	1.635 (42mm)	4.5 (114mm)	3.270 (83mm)	1.135 (29mm)	1/2 (13mm)	.615 (16mm)
FE (7 3/4 x 4 3/4)	7 1/2 (191mm)	6 1/4 (159mm)	3 1/8 (79mm)	4 1/2 (114mm)	3 1/2 (89mm)	1 1/4 (32mm)	9/16 (14mm)	1/2 (13mm)
PA (6 1/2 x 3 3/4)	6 1/2 (165mm)	5 1/2 (140mm)	2 3/4 (70mm)	3 3/4 (95mm)	2 5/8 (67mm)	1 1/8 (29mm)	9/16 (14mm)	5/8 (16mm)
SH & BU (6 1/4 x 4)	6 1/4 (159mm)	5 (127mm)	2 1/2 (64mm)	4 (102mm)	2 3/4 (70mm)	1 1/8 (29mm)	9/16 (14mm)	5/8 (16mm)
SK (6 1/8 x 4 1/8)	6.13 (156mm)	4.94 (125mm)	2.47 (63mm)	4.13 (105mm)	2.69 (68mm)	1.03 (26mm)	9/16 (14mm)	.75 (19mm)
ST (5 x 5)	5 (127mm)	3 3/4 (95mm)	1 7/8 (48mm)	5 (127mm)	3 3/4 (95mm)	1 1/8 (29mm)	1/2 (13mm)	5/8 (16mm)
WI (5 x 5)	5 (127mm)	4 1/8 (105mm)	2 1/16 (53mm)	5 (127mm)	4 1/8 (105mm)	1 5/16 (33mm)	7/16 (11mm)	7/16 (11mm)

*See Motor Price Sheet for C-AH dimension
All Dimensions in inches (millimeters)

Horizontal Pedestal Mounted

P3 Bearing Frame

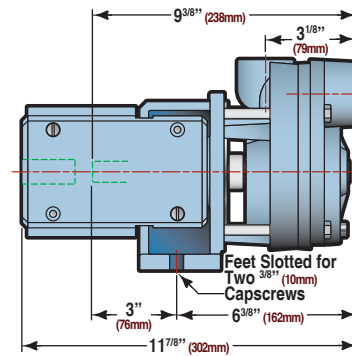
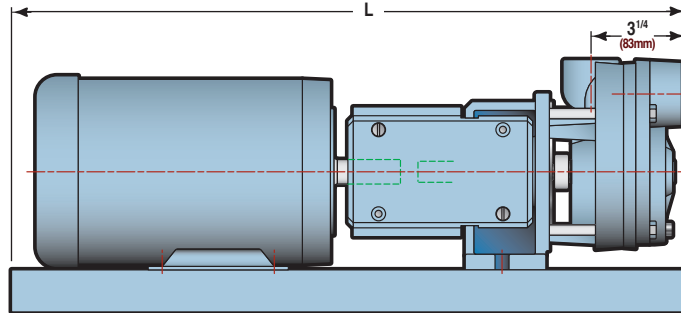
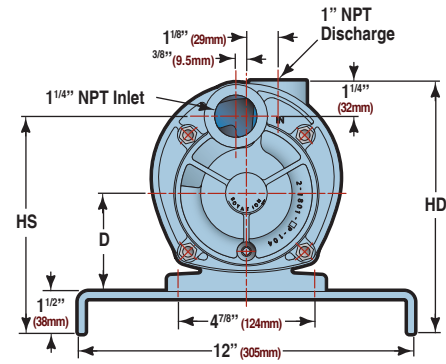
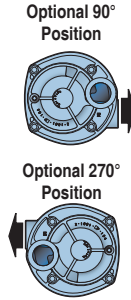
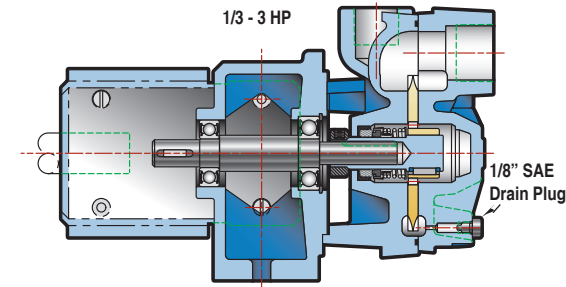

P15 Bearing Frame

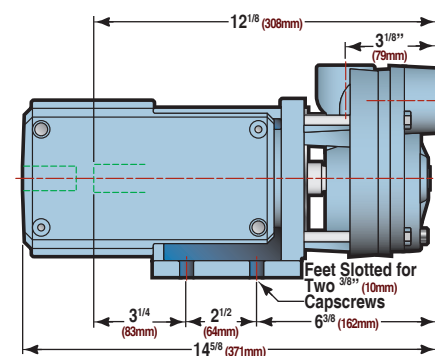
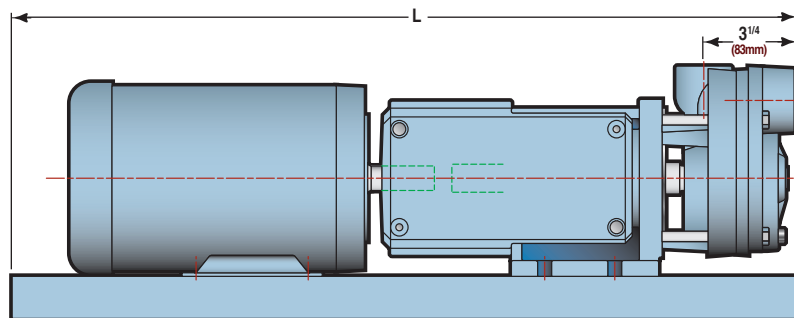
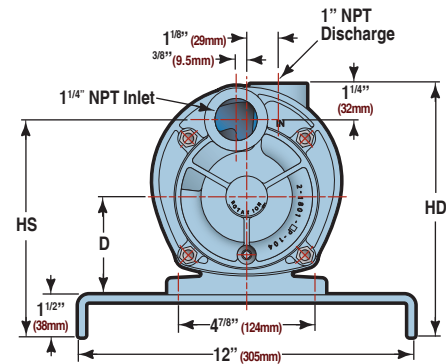
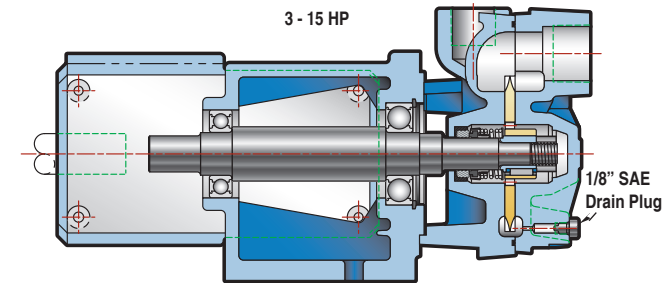

FRAME	D	HD	HS	L (P3)	L (P15)
56 T	3 1/2 (89mm)	9 (229mm)	7 3/4 (197mm)	24 (610mm)	
143 T	3 1/2 (89mm)	9 (229mm)	7 3/4 (197mm)	24 (610mm)	28 (711mm)
145 T	3 1/2 (89mm)	9 (229mm)	7 3/4 (197mm)	24 (610mm)	28 (711mm)
182 T	4 1/2 (114mm)	10 (254mm)	8 3/4 (222mm)	26 (660mm)	30 (762mm)
184 T	4 1/2 (114mm)	10 (254mm)	8 3/4 (222mm)	26 (660mm)	30 (762mm)
213 T	5 1/4 (133mm)	10 3/4 (273mm)	9 1/2 (241mm)		33 (838mm)
215 T	5 1/4 (133mm)	10 3/4 (273mm)	9 1/2 (241mm)		33 (838mm)

All dimensions in inches (millimeters). May vary ±1/4 inches

M51 Series Single Stage (M51)

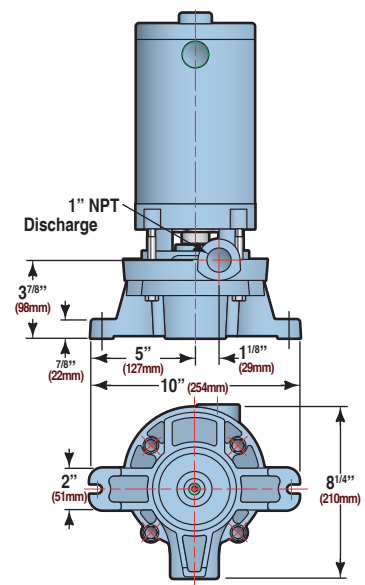
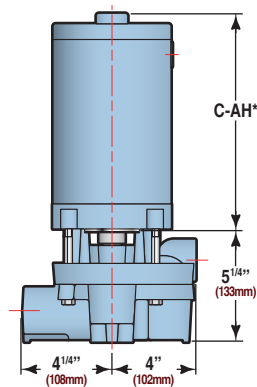
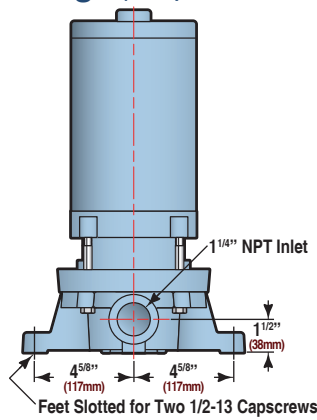

*See Motor Price Sheet for C-AH dimension

T51 • E51 • M51 Series

Engineering Specifications

Horizontal Close-Coupled

The contractor shall furnish (and install as shown on the plans) an MTH (E51)(T51) Series horizontal close coupled regenerative turbine type pump model _____ size 1" by 1 1/4" of (BRONZE FITTED) (ALL IRON) (ALL BRONZE) (316 STAINLESS STEEL) construction. Each pump shall have a capacity of _____ GPM when operating at a total head of _____ feet. Suction pressure will be _____ feet with a liquid temperature of _____ degrees F.

The pump is to be furnished with a mechanical seal with stainless steel metal parts, _____ elastomers, ceramic seat and carbon washer. A shaft sleeve or 304 SS shaft shall be furnished in pumps up to three horsepower and a 316 stainless steel shaft in pumps five horsepower and larger.

The pump casing shall be vertically split two piece, end suction and (TOP DISCHARGE) (90° DISCHARGE) (180° DISCHARGE) (270° DISCHARGE) with water passageways in each piece. The impeller shall be hydraulically self-centering and no external adjustment shall be necessary.

The pump shall be close-coupled to a _____ HP _____ Phase _____ Hertz _____ Volt _____ RPM horizontal (OPEN DRIP-PROOF) (TOTALLY ENCLOSED) (EXPLOSION PROOF) motor. The motor shall be sized to prevent overloading at the highest head condition listed in the specifications.

Vertical Flange Mount

The contractor shall furnish (and install as shown on the plans) an MTH (T51)(E51) Series vertical close coupled flange mount regenerative turbine type pump model _____ of (BRONZE FITTED) (ALL IRON) (ALL BRONZE) construction. Each pump shall have a capacity of _____ GPM when operating at a total head of _____ feet with a _____ style suction flange and a 1" discharge. Suction pressure will be _____ feet with a liquid temperature of _____ degrees F.

The pump is to be furnished with a mechanical seal with stainless steel metal parts, _____ elastomers, ceramic seat and carbon washer. A shaft sleeve or 304SS shaft shall be furnished in pumps up to three horsepower and a 316 stainless steel shaft in pumps five horsepower

and larger.

The pump casing shall be vertically split two piece design with water passageways in each piece. The impeller shall be hydraulically self-centering and no external adjustment shall be necessary.

The pump shall be close-coupled to a _____ HP _____ Phase _____ Hertz _____ Volt _____ RPM horizontal (OPEN DRIPPROOF) (TOTALLY ENCLOSED) (EXPLOSION PROOF) motor. The motor shall be sized to prevent overloading at the highest head condition listed in the specifications.

M51 Series Close Coupled

The contractor shall furnish (and install as shown on the plans) an MTH M50 Series (horizontal) (vertical base mount) close coupled regenerative turbine type pump model _____ size _____ of (BRONZE FITTED) (ALL IRON) (ALL BRONZE) (316 STAINLESS STEEL) construction. Each pump shall have a capacity of _____ GPM when operating at a total head of _____ feet. Suction pressure will be _____ feet with a liquid temperature of _____ degrees F.

The pump is to be furnished with a mechanical seal with stainless steel metal parts, (Buna) (EPR) (Teflon) (Viton) elastomers, (ceramic) (ni-resist) (silicon carbide) (tungsten carbide) seat and carbon washer. Pump will have shaft sleeve or stainless steel shaft which will prevent pumped fluid from contacting motor shaft.

The pump shall be vertically split design with replaceable external channel rings that have water passageways accurately machined into each ring. The suction and discharge will have (NPT) (SAE) (BSP) (ISO) threads located in the top vertical position for self-venting and shall be cast separately from one another. The impeller(s) shall be hydraulically self-centering and no external adjustment shall be necessary. The pump shall be mounted to a standard NEMA _____ HP _____ phase _____ Hertz _____ volt _____ RPM (horizontal) (vertical), (open dripproof) (totally enclosed) (explosion proof) motor. Each pump shall be tested at the specified capacity and head prior to shipment. The motor shall be sized to prevent overloading at the highest head condition listed in the specifications.

Horizontal Pedestal Mount

The contractor shall furnish (and install as shown on the plans) an MTH T51 Series horizontal pedestal mount regenerative turbine type pump model _____ size 1" by 1 1/4" of (BRONZE FITTED) (ALL IRON) (ALL BRONZE) (316 STAINLESS STEEL) construction. Each pump shall have a capacity of _____ GPM when operating at a total head of _____ feet. Suction pressure will be _____ feet with a liquid temperature of _____ degrees F.

The pump is to be furnished with a mechanical seal with stainless steel metal parts, _____ elastomers, ceramic seat and carbon washer. A shaft sleeve shall be furnished in pumps up to three horsepower and a 316 stainless steel shaft in pumps five horsepower and larger.

The pump casing shall be vertically split two piece, end suction and (TOP DISCHARGE) (90° DISCHARGE) (270° DISCHARGE) with water passageways in each piece. The impeller shall be hydraulically self-centering and no external adjustment shall be necessary.

The pump shall be mounted on a bearing pedestal with sealed, grease lubricated ball bearings having a two year minimum design life under a maximum pump differential pressure of 300 PSI. The pump shaft shall be of 416 stainless steel construction for up to three horsepower driver, and of 316 stainless steel construction for five horsepower and larger driver. Pump and motor shall be mounted on a common steel baseplate (WITH CAST IRON DRIP PAN). The pump is to be flexible-coupled with aluminum coupling guard to a standard horizontal NEMA _____ HP _____ Phase _____ Hertz _____ Volt _____ RPM horizontal (OPEN DRIPPROOF) (TOTALLY ENCLOSED) (EXPLOSION PROOF) motor. The motor shall be sized to prevent overloading at the highest head condition listed in the specifications. Coupling alignment shall be checked after installation.

Performance Curves

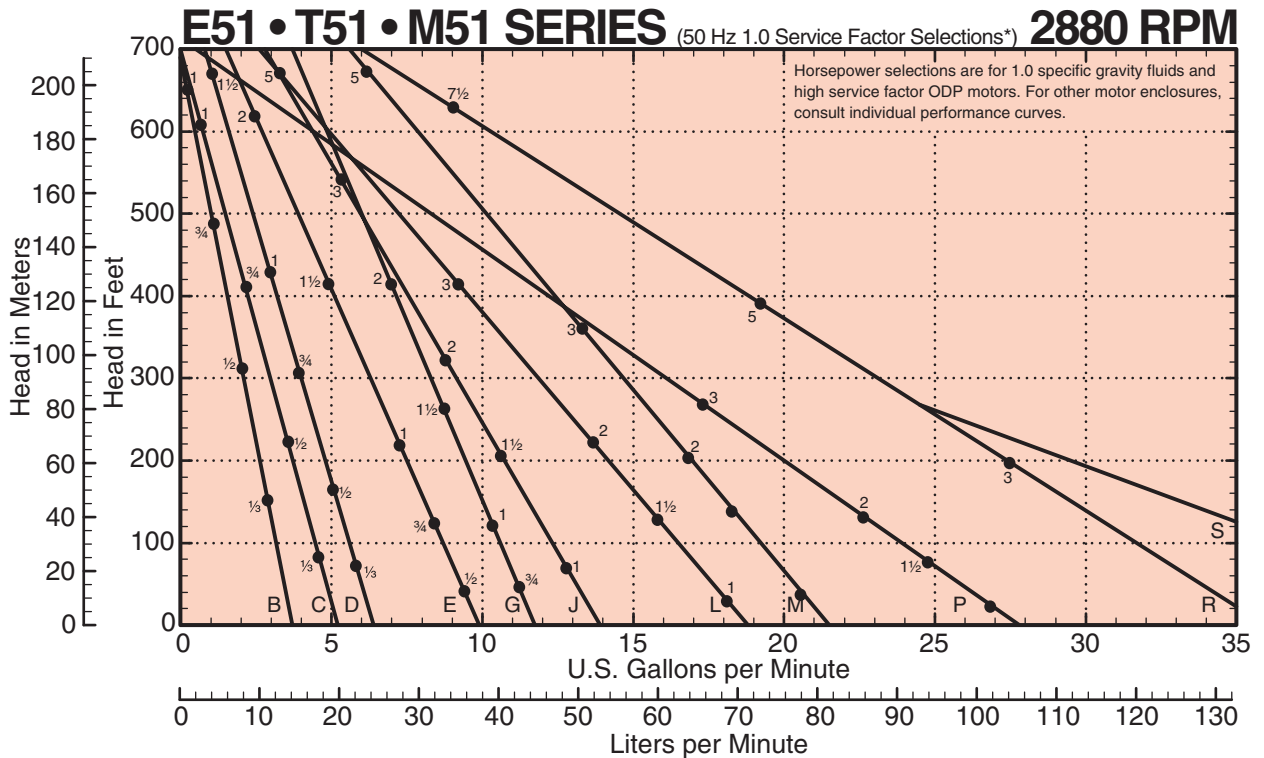
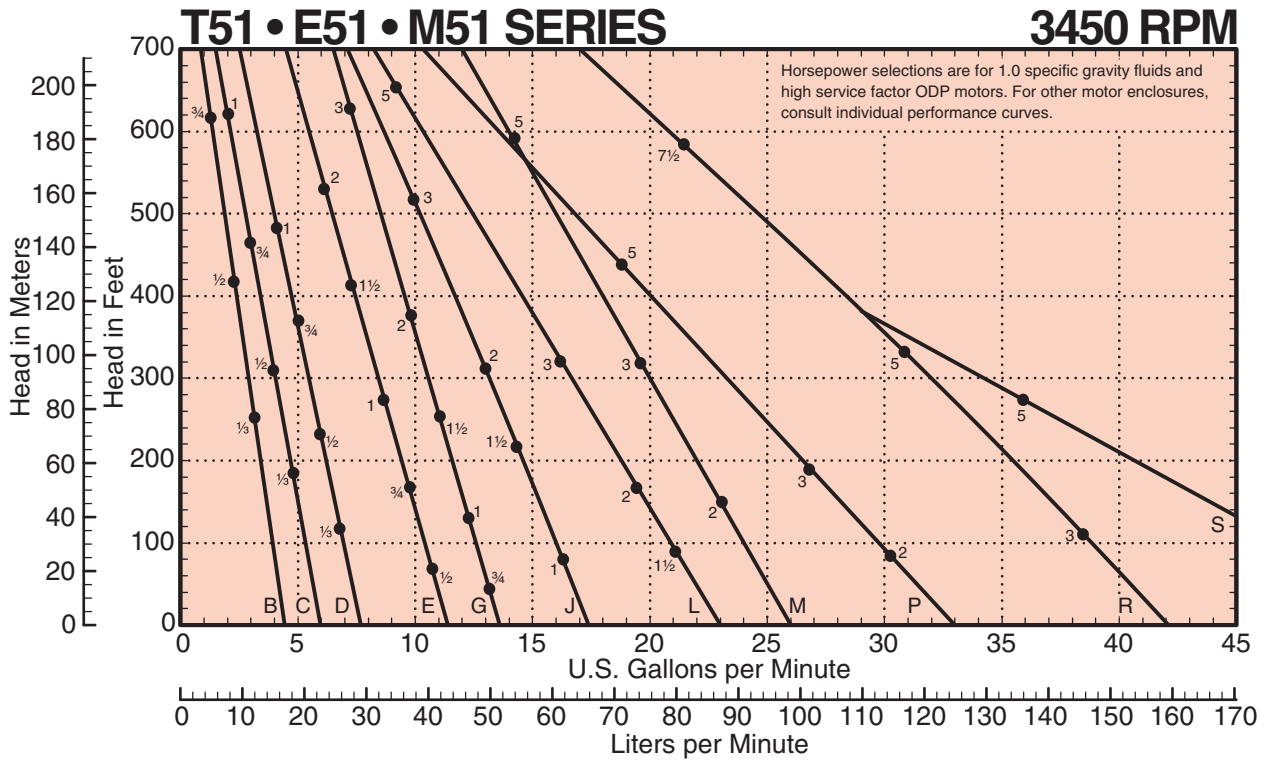

 **WARNING:**
CANCER AND REPRODUCTIVE HARM
WWW.P65WARNINGS.CA.GOV



*Manufacturing MTH Pumps
in the USA since 1965
ISO Registered Company*



MTH PUMPS

401 West Main Street • Plano, IL 60545-1436
Phone: 630-552-4115 • Fax: 630-552-3688
Email: SALES@MTHPUMPS.COM