

Richter Vortex Type Chemical Process Pumps



Higher solids contents
Larger and fibrous particles
Gas-laden media
Materials: PFA,
PTFE, PE-UHMW



RICHTER
Process Pumps & Valves



Conveyance of solids-containing and gas-laden media

Vortex pumps are preferably used for media with higher solids contents. In addition, they have relatively good gas/liquid pumping capability.

Media are conveyed gently for pump and medium

- Solids contents of up to roughly 50 % by volume, depending on grain sizes and properties
- Particle sizes of about $\frac{2}{5}$ - $\frac{4}{5}$ " (10 to 20 mm), depending on the pump size
- Long-fibre constituents
- Gas contents of up to 5 % by volume

Pressure/temperature range

- Operating temperature: -75 to 360 °F (-60 to +180 °C), depending on design and operating pressure
- Operating pressure up to 145 or 235 psi (10 bar or 16 bar), depending on housing design
- Version for elevated vacuum (at standstill) optional

Flanges

- for connection to DIN 2533/PN 16, on request for connection to ANSI or BS

Type code

- | | |
|---------------------------------------|------------|
| • with magnetic drive, frame-mounted | MNK-X/... |
| • with magnetic drive, close-coupled | MNK-XB/... |
| • with mechanical seal, frame-mounted | SCK-X/... |
| • PFA/PTFE lining | .../F |
| • PE-UHMW lining | .../E |

Antistatic and PFA-P highly permeation resistant linings on request.

Fields of application

Solids-containing media

Centrifugal pumps of standard designs involve the risk that solids may clog the impeller channels – especially with closed impellers – or cause increased wear in the space between the impeller and the housing. Richter vortex pumps have large free spaces in the housing and the medium rotates in the vane-less area! Gentle conveyance of media with fibrous or crystalline constituents.

Gas-laden media

Standard centrifugal pumps can convey liquids with a gas content of up to 3 % by volume. If the gas content is higher, delivery fails and is not resumed even after the gas volume has been reduced: The pump must be shut down.

By contrast, Richter vortex pumps can also convey gas contents of up to 5 % at a minimum flow rate of about 20 % Q_{optimum} .

If the gas content exceeds 5 %, the delivery head drops sharply until delivery stops. However, delivery continues again immediately after a reduction in the gas volume without the pump having to be shut down.

Vortex pumps as mixers

When a vortex pump is used as a mixer, which in many cases would otherwise be necessary, can be dispensed with: As a result of the strong circulation currents, the liquids to be conveyed are intimately mixed inside the pump and then discharged.

Favourable cavitation behaviour

Vortex pumps exhibit excellent cavitation behaviour. Although cavitation occurs somewhat earlier than in standard centrifugal pumps, the cavitation curves become much flatter.

The pump therefore maintains delivery at a slightly reduced head for longer than a comparable standard centrifugal pump. No cavitation damage is to be expected as cavitation would occur in the liquid-filled free space of the housing.

Flow rates

The Q/H performance curve of a vortex pump runs comparatively flat: The delivery head is smaller in the lower rate range than with a standard centrifugal pump but higher in the upper range.

① **Pump housing**

- Ductile cast iron EN-JS 1049/ASTM A395 with thick lining made of PFA/PTFE, PE-UHMW, PP
- Connection for housing drain as standard
- Highly permeation-resistant and antistatic linings on request

② **Semi-open vortex impellers**

- Positioned outside the main flow
- Radial vanes
- Large metal core for increased stability
- Secured against detachment in the event of start-up in the wrong direction of rotation
- Back vanes reduce axial thrust forces

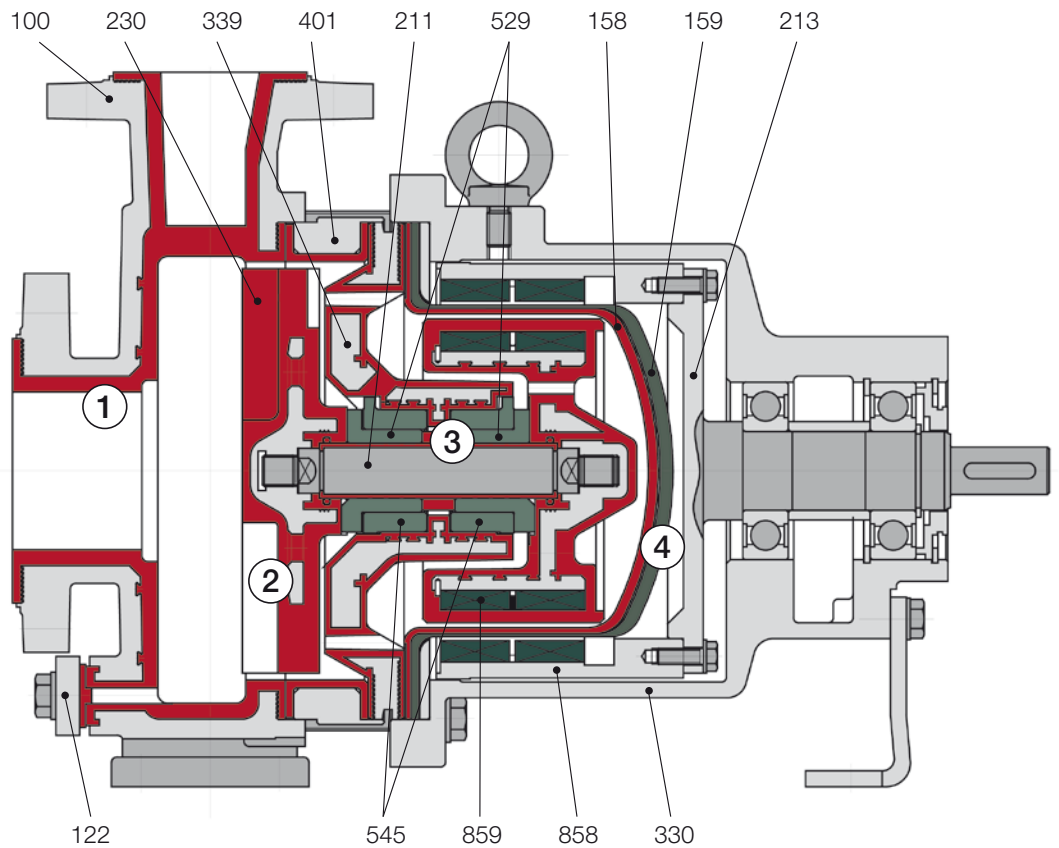

Vortex pump MNK-X with magnetic drive, frame-mounted design

(alternatively close-coupled design MNK-XB up to size 3"-2"-8" (80-50-200)). In the event of higher solids content, flushing of the can chamber must be provided (not illustrated here, see cover photo and publication No. 657).

Reliable: magnetic drive or mechanical seals

Magnetic drive pumps

- **Plain bearings** ③ made of pure SSiC and optionally with SAFEGLIDE® PLUS: protection against damage in case of dry-running
- Non-metallic, eddy-current-free **can systems** ④ made of CFRP/PTFE, can monitoring connection on request
- A **special plain bearing and can flushing system** can be provided, depending on the content and type of solids (see illustration on cover)

Alternative to the vortex magnetic drive pump MNK-X (frame-mounted) or MNK-XB (close-coupled):

Mechanical seal vortex pump SCK-X of frame-mounted design

- Internal or external **mechanical seal** ⑤
- **Heavy-duty design** also for high and varying loads, minimal shaft deflection
- **Shaft sleeve** ⑥ Al₂O₃, SSiC, Hastelloy® etc.

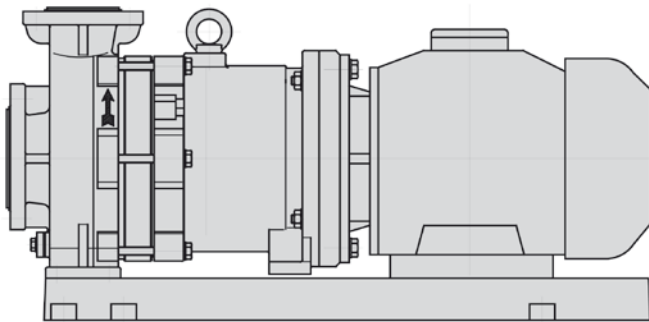

Series MNK-XB with magnetic drive, close-coupled

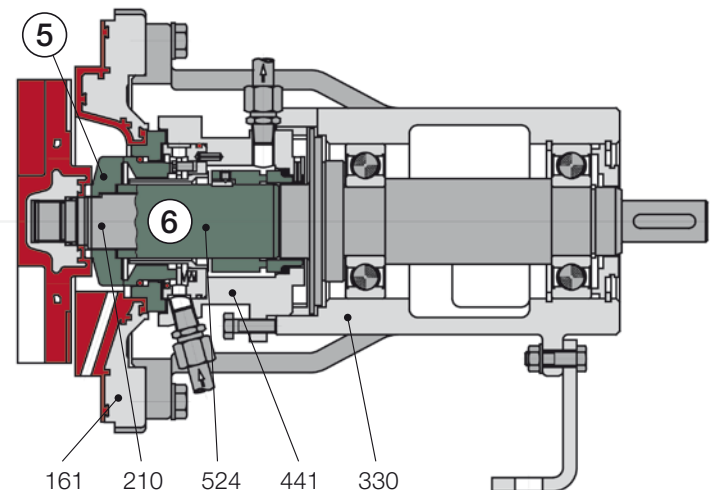

Series SCK-X with internal non-metallic double mechanical seal

For detailed sectional drawings and descriptions of the basic pumps, refer to publications MNK and SCK. For Richter mechanical seal RG-4 and plain bearings SAFEGLIDE® PLUS please request special literature.

Components and materials

Item	Designation	Standard design*
100	Pump housing	Ductile iron EN-JS 1049 ASTM A395/PFA, PTFE, PE-UHMW
122	Blind cover	Ductile iron EN-JS 1049 ASTM A395/PTFE
158	Can insert	PTFE
159	Can	CFRP carbon-fibre compound
161	Back plate	Ductile iron EN-JS ASTM A395/PFA, PTFE, PE-UHMW
210	Pump shaft	Stainless steel
211	Pump shaft	Stainless steel/PFA
213	Drive shaft	Steel
230	Impeller	PFA, PE-UHMW ductile cast iron core
330	Bearing pedestal	Ductile iron EN-JS 1049 ASTM A395
339	Plain bearing pedestal	Ductile iron EN-JS 1049 ASTM A395/PFA, PE-UHMW
401	Distance ring	Stainless steel/PTFE, PE-UHMW
441	Mechanical seal housing	Stainless steel
524	Shaft sleeve	Al ₂ O ₃ , SiC etc. depending on specifications
529	Bearing sleeve	Pure SiC, on request with SAFEGLIDE® PLUS
545	Bearing bush	Pure SiC, on request with SAFEGLIDE® PLUS
858	Drive magnet assembly	Steel/permanent magnets
859	Inner magnet assembly	Steel/PFA, permanent magnets

* Antistatic and PFA-P highly permeation-resistant linings available on request

Higher delivery capacities on request.

Richter vortex pumps are also available for 1,750 and 3,500 rpm for flows up to 880 USgpm (200 m³/h) and TDH up to 395 ft (120 m).

For 60 Hz curves please contact factory.

Flow rates

Performance curves 2900 rpm

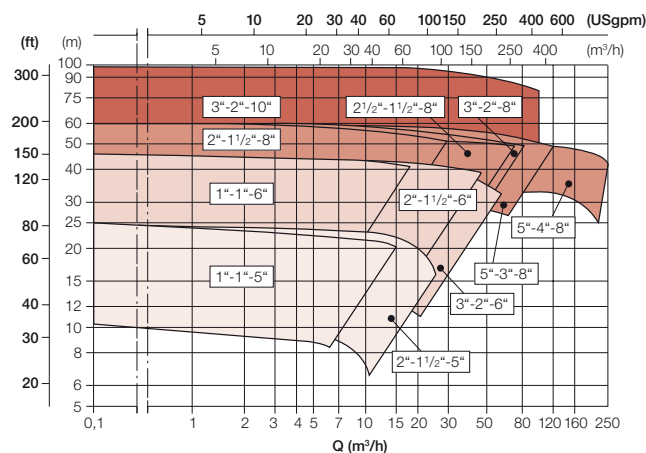

Performance curves 1450 rpm

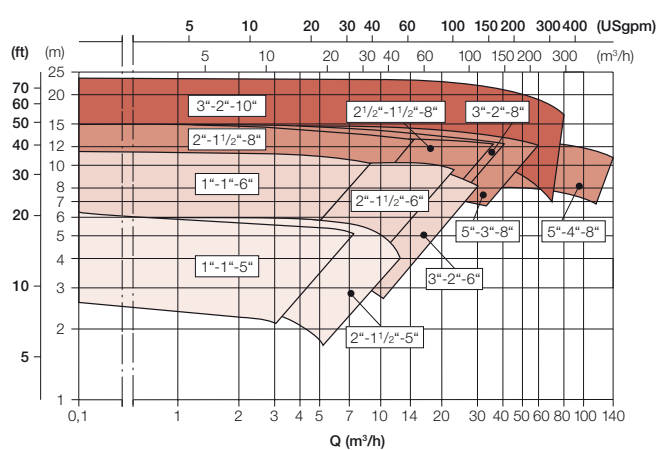

Presented by:

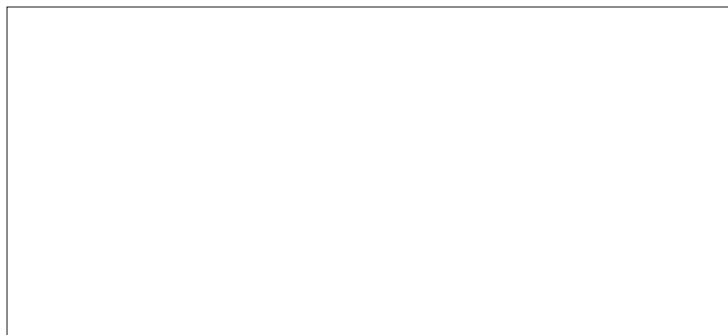

Richter Inc.

A Unit of IDEX Corporation

406 State Street, Cedar Falls, 50613 IA, USA

Tel. +1(319) 268-8038, Fax +1(803) 216-7702

Headquarter:

Richter Chemie-Technik GmbH

Otto-Schott-Str. 2, D-47906 Kempen, Germany

Tel. +49(0)21 52/146-0, Fax +49(0)21 52/146-190

www.richter-ct.com, richter-info@idexcorp.com