

INSTALLATION AND OPERATING MANUAL

Translation of the original manual

Series MNK

Sealless Chemical Magnetic Drive Pump

Bearing lubrication: Grease and oil bath

Bearing pedestal group: 1+2



Keep for future use!

This operating manual must be strictly observed before transport, installation, operation and maintenance

Subject to change without notice.

Reproduction is generally permitted with indication of the source.

© Richter Chemie-Technik GmbH

9230-001-en Revision 15 Edition 01/2021



List of Contents

List of Contents	2
Relevant documents	3
1 Technical data	3
1.1 Tightening torques	4
1.2 Type plate, dry-running, ATEX-and housing markings	4
1.3 Spare parts	4
2 Notes on safety	5
2.1 Intended use	5
2.2 For the customer/operator	6
2.3 For maintenance	6
2.4 Conversion work and production of spare parts by the customer	6
2.5 Improper operation	6
2.6 Special requirements for explosion protection	6
2.6.1 Filling the unit	6
2.6.2 Special operating conditions	7
2.6.3 Chargeable liquids	7
2.6.4 Identification	7
2.6.5 Check of the direction of rotation	7
2.6.6 Mode of operation of the pump	7
2.6.7 Temperature limits	8
2.6.8 Maintenance	8
2.6.9 Electric peripheral equipment	8
3 Transport, storage and disposal	9
3.1 Return consignments	9
3.2 Disposal	9
4 Product description	10
5 Installation	10
5.1 Safety regulations	10
5.2 Installation of pump / unit	10
5.3 Alignment of pump-coupling-motor	10
5.4 Piping	11
5.4.1 Nominal size	11
5.4.2 Nozzle loads	11
5.4.3 Suction line	11
5.4.4 Supply lines	11
5.4.5 Discharge line	11
5.4.6 Venting and draining	11
5.5 Pipe fittings	12
5.6 Monitoring facilities	12
5.7 Drive	12
5.8 Coupling	12
5.9 Final check	13
5.10 Coupling guard	13
5.11 Electric connection	13
6 Commissioning/Shutdown	13
6.1 Initial commissioning	13
6.1.1 Filling the pump housing	13
6.1.2 Start-up	13
6.2 Operating limits	14
6.2.1 Abrasive media	14
6.2.2 Min./max. flow rate	14
6.3 Shutdown	14
6.4 Restarting	14
6.5 Improper operations and their consequences (examples)	14
7 Maintenance	15
7.1 Screw connections of the housing	15
7.2 Bearing pedestal	15
7.2.1 Long life grease lubrication	15
7.2.2 Oil bath lubrication	15
7.3 Cleaning	16
7.4 Stand-by pumps	16
7.5 Notes on dismantling	16
7.5.1 Protective clothing	16
7.5.2 Magnetic fields	16
7.6 Dismantling	16
7.6.1 Dismantling the slide-in unit	17
7.6.2 Dismantling the drive unit Long life grease lubrication	17
7.6.3 Changing the radial ball bearings Long life grease lubrication	17
7.6.4 Dismantling the drive unit Oil bath lubrication	17
7.6.5 Changing the radial ball bearings Oil bath lubrication	18
7.6.6 Changing the temperature sensor PT 100 at the plain bearing pedestal	18
7.7 Notes on assembly	18
7.8 Assembly	19
7.8.1 Assembly of drive unit Long life grease lubrication	19
7.8.2 Assembly of drive unit Oil bath lubrication	19
7.8.3 Perform trial assembly of plain bearing pedestal with impeller, inner magnet assembly and plain bearings	19
7.8.4 Determine thicknesses S_1 and S_2 of the distance washers 551	19
7.8.5 Final assembly	20
7.8.6 Fill bearing pedestal with oil	20
7.9 Tests	20
8 Malfunctions	21
9 Sectional drawing	22
9.1 Legend	22
9.2 MNK with grease lubrication	23
9.3 MNK with oil bath lubrication	24
10 Assembly aids	25
10.1 Boring templates	25
10.2 Installation device for plain bearings	25
10.3 Pull-off device for plain bearing bushes	25

Relevant documents

Data sheet	
Works certificate	
Sectional drawing	
MNK greased for life	9230-00-3000
MNK oil bath lubrication	9230-00-3001
Installation drawing	
MNK assembly drawing (grease)	9230-00-3011
MNK assembly drawing (oil bath)	9230-00-3012
Performance curves	
Spare parts list	
Operating manual and declaration of conformity motor *	
Operating manual and declaration of conformity coupling *	
Supplementary Installation and Operating Manual for external flushing	9230B010-en *
Supplementary Installation and Operating Manual, vortex pump	9230B011-en *
Supplementary Installation and Operating Manual, „self-priming“ design	9230B012-en *

Supplementary Installation and Operating Manual, „SAFESEAL®“	9230B025-en *
Supplementary Installation and Operating Manual, „SAFERUN®“	9230B020-en *
Supplementary Installation and Operating Manual, „heating jacket“	9000B001-en *

* if contained in the scope of delivery

Appendix to the operating instructions

Operational limits 9200-00-3030

Declaration of conformity with ATEX

Declaration of conformity without ATEX

Form for Safety Information Concerning the Contamination QM 0912-16-2001_en

On request:

Magnetic drive data Richter TIS 0543-03-0001

Nozzle loads TIS 0541-02-0006

Publication: "Centrifugal Pump Operation without NSPH Problems"

Publication "Safe Operation of Magnetic Drive Pumps"

1 Technical data

Manufacturer :

Richter Chemie-Technik GmbH
 Otto-Schott-Str. 2
 D-47906 Kempen
 Telephone: +49 (0) 2152 146-0
 Fax: +49 (0) 2152 146-190
 E-Mail: richter-info@idexcorp.com
 Internet: <http://www.richter-ct.com>

Authorised person acc. to machinery directive 2006/42/EG: Gregor Kleining

Designation :

Single-stage, plastic-lined, magnetic drive chemical centrifugal pump, series MNK, long life grease and oil bath lubrication

Heavy-duty horizontal design, sealless, free of eddy currents

Technical specifications to ISO 15783 and DIN ISO 5199

Connecting dimensions to ISO 2858 / DIN EN 22858

Flange connecting dimensions:

DIN EN 1092-2, type B (ISO 7005-2, type B) PN 16 or flanges drilled to ASME 16.5, Class 150

ATEX Directive 2014/34/EU

Machine Directive 2006/42/EC

Materials :

Pressurized parts :

ductile cast iron EN-JS 1049 / ASTM A395, carbon fibre composite material

Wetted parts :

PFA, PTFE, PE-UHMW, PP, PFA-P, anti-static lining (PFA/PTFE conductive) SSiC, FKM/FFKM see also data sheet.

Flow rate : up to 300 m³/h (bei 2900 min⁻¹)

Delivery head : up to 110 m LC (bei 2900 min⁻¹)

Housing discharge pressure : max. 16 bar detailed data see operational limits

Temperature range : - 60 °C to + 180 °C

Note: Consult the manufacturer for higher pressures and lower or higher temperatures.

Noise capacity level : L_{WA} = ≤ 70 dB acc. to DIN EN ISO 9614-2

Temperature classes : see Section 2.6.7

Admissible ambient conditions for pumps acc. to directive 2014/34/EU (ATEX) :

Ambient temperature range: - 20 °C to + 60 °C

Ambient pressure range: 0,8 bar_{abs} to 1,1 bar_{abs}

Noise capacity level : L_{WA} = ≤ 70 dB nach DIN EN ISO 9614-2

Weight : See data sheet

Dimensions : See installation drawing

Sizes:

Group 1.1	Group 1.2	Group 1.3	Group 2
25-25-125	25-25-160	50-32-200	80-50-250
50-32-125	50-32-160	65-40-200	125-80-200
	80-50-160	80-50-200	125-100-200

1.1 Tightening torques

Screws greased, tighten in diametrically opposite sequence

Housing screws 901/3

Size [mm]	No. x size [DIN/ISO]	Tightening torque [Nm]
25-25-125	8 x M 10	20
50-32-125	8 x M 10	20
25-25-160	6 x M 10	45
50-32-160	6 x M 10	45
80-50-160	6 x M 10	45
50-32-200	8 x M 12	45
65-40-200	8 x M 12	45
80-50-200	8 x M 12	45
80-50-250	8 x M 12	60
125-80-200	8 x M 12	60
125-100-200	8 x M 12	60

Pipe screws, flanges to DIN/ISO

DN [mm]	No. x size [DIN/ISO]	Tightening torque [Nm]
25	4 x M 12	10
32	4 x M 16	15
40	4 x M 16	20
50	4 x M 16	26
65	4 x M 16	40
80	8 x M 16	25
100	8 x M 16	35
125	8 x M 16	45

Pipe screws, DIN/ISO flanges drilled to ASME

DN [mm]		No. x size [ASME]	Tightening torque	
[mm]	[inch]		[Nm]	[in-lbs]
25	1"	4 x 1/2"	8	70
32	1 1/4"	4 x 1/2"	12	105
40	1 1/2"	4 x 1/2"	15	135
50	2"	4 x 5/8"	25	220
65	2 1/2"	4 x 5/8"	30	265
80	3"	4 x 5/8"	45	400
100	4"	8 x 5/8"	35	310
125	5"	8 x 3/4"	55	485

1.2 Type plate, dry-running, ATEX- and housing markings

The stainless steel type plate is firmly riveted to the housing:

If the operator attaches his identification, it must be ensured that the pump matches the application in question.

Example of type plate:

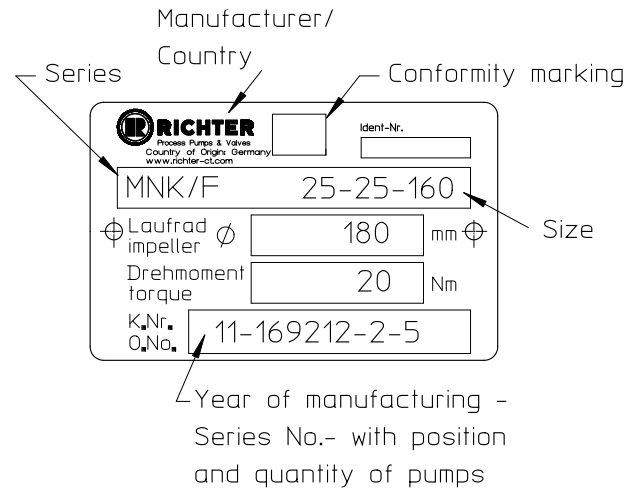

Dry-running:

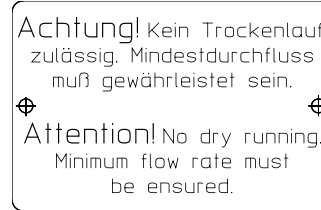

ATEX marking:

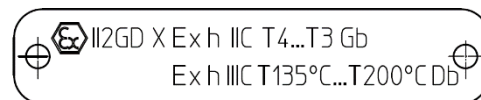

Housing identification:

The following are visible on the housing according to DIN EN 19:

- Nominal size
- Rated pressure
- Housing material
- Manufacturer's identification
- Melt number/Foundry identification
- Cast date

1.3 Spare parts

Spare parts for two years of continuous operation in accordance with DIN 24296 and in consultation with the manufacturer

2 Notes on safety

This operating manual contains fundamental information which is to be observed during installation, operation and maintenance.

It must be read before installation and commissioning.

This operating manual must always be available at the place of use of the machine/plant.

In addition to the general notes on safety under the main heading "Safety", special notes on safety are included at other points and must be observed.

Installation, operation and maintenance are to be performed by qualified staff.

The area of responsibility, authority and supervision of the staff must be exactly regulated by the customer.

If the staff does not have the necessary expertise, they are to be trained and instructed.

If necessary, this can be provided by the manufacturer/supplier on behalf of the machine operator.



General hazard symbol! People may be put at risk.



Safety symbol! The pump and its function may be put at risk if this safety symbol is not observed.



EU marking! Explosion-protected equipment must be identified for work in potentially explosive areas.



Warning of a magnetic field!



Warning of electric power!



This warning sign must be used if people with a pacemaker are at risk, e.g. from a strong magnetic field.

It is imperative to observe signs attached directly to the pump / unit, e.g.:

Direction of rotation arrow

Warning against dry-running

and they are to be kept legible.

Non-observance of the notes on safety may result in the loss of any and all claims for damages.

Non-observance may involve the following hazards:

Failure of important functions of the machine/plant.

Failure of electronic equipment and measuring instruments due to magnetic fields.

Risk to people and their personal property from magnetic fields.

Risk to people from electric, mechanical and chemical effects.

Risks to the environment through leaks of hazardous substances.



If the unit is used in potentially explosive areas, special attention is to be paid to the sections identified with "Ex" in this operating manual.

2.1 Intended use

Richter pumps of the series MNK are plastic-lined magnetic drive centrifugal pumps for the leak-free conveyance of aggressive, toxic, pure and inflammable liquids.

The pump is equipped with a permanent magnetic synchronous drive.

Vertical installation of the pumps is only possible with pumps with grease-lubricated ball bearings or ball bearings with oil mist lubrication. Please consult the manufacturer.



The observance of the specified physical limits is important for perfect functioning and safe operation, especially with regard to explosion protection to prevent potential sources of ignition (see **Section 2.6**):

It must be ensured that the pump is always filled with liquid during operation.

For safe pump operation, we recommend a flow rate which lies between 0.3 and 1.1 Q_{opt} . The maximum operating temperature must never be exceeded. See **Section 2.6.7**. In case of doubt, you must consult the manufacturer.

The manufacturer must be consulted in the event of entrainment of gas >2% as well as solids in order to avoid a lack of lubrication and dry-running.

The plant NPSH value (NPSHA) should be 0.5 m higher than the NPSH value of the pump (NPSHR). See also **Section 5.4.1**.



Improper operation, even for a short period, may result in serious damage to the unit.

In connection with explosion protection, potential sources of ignition (overheating, electrostatic and induced charges, mechanical and electric sparks) may result from these inadmissible modes of operation; their occurrence can only be prevented by adhering to the intended use.

Furthermore, reference is made in this connection to the Directive 1999/92/EG („ATEX 137“) which contains the minimum regulations for improving the occupational health and safety of the workers who may be at risk from an explosive atmosphere.



This unit must not be operated above the values specified in the data sheet as regards the fluid to be conveyed, flow rate, speed, density, delivery head and operating temperature as well as the motor rating.

The instructions contained in the operating manual or contract documentation must be observed; if necessary consult the manufacturer.

All important features are documented in the data sheet included in the scope of delivery.

In the event of operating conditions other than those described in the data sheet, the following are to be checked again:

design of the pump

design of the accessories

resistance of the materials.

2.2 For the customer/operator

The following must be observed:

The notes on safety contained in this operating manual, the prevailing regulations on accident prevention, in-house work, operating and safety regulations of the customer.

Hot or cold machine parts must be protected by the customer against being touched.

No protective facilities may be removed when the machine is in operation.

The ring bolt **900/1** must not be removed or loosened as deposits could form between the drive magnet assembly and the lantern. For example, overheating and thus potential sources of ignition could arise due to frictional energy.



Hazards due to electricity are to be excluded.

Leaks of hazardous media (e.g. explosive, toxic, hot) must be removed so that no risk arises for people and the environment. The statutory provisions are to be observed.



Caution when using the units in potentially explosive area! Inadmissible modes of operation must be prevented.

2.3 For maintenance

In principle, work on the unit may only be performed when it is at a standstill.

It is imperative to observe the procedure for stopping the machine described in this operating manual. See **Section 6.3**.

Pumps which convey media which are a health hazard must be decontaminated.

All safety and protective facilities must be remounted or enabled immediately after the end of work.

In the assemble state, if the safety notes (see also **Section 5.1 and 7.5.2**) are observed, the magnetic drives do not cause any risks or have any affect on the environment.



During dismantling and assembly as well as during transport and storage of the magnetic drives as single components, the notes on safety in **Section 7.5.2** must be observed.

The points listed in **Section 6.1** must be followed before

2.4 Conversion work and production of spare parts by the customer

Conversion of or changes to the machine are only admissible after consultation with the manufacturer.

Original spare parts and accessories authorised by the manufacturer serve to enhance safety.

The use of other parts may annul the liability for any resultant consequences.

2.5 Improper operation

The operational safety of the machine supplied is only guaranteed if it is used properly in accordance with **Section 2.1** of this operating manual.

The operating limits specified in the data sheet must under no circumstances be exceeded.

2.6 Special requirements for explosion protection

If the units are used in potentially explosive areas, the measures and notes in **Sections 2.6.1 to 2.6.9** are imperative to guarantee the explosion protection.

2.6.1 Filling the unit



During pump operation the wetted interior of the pump must always be filled with the liquid medium.

This prevents any explosive atmosphere and the risk of dry-running.



If the customer cannot ensure this, we recommend that appropriate monitoring facilities be provided.



All auxiliary, heating and cooling systems must also be carefully filled.

2.6.2 Special operating conditions



In the standard design the can chamber and the plain bearings are cooled and lubricated by a flushing flow.

Owing to properties of the medium (e.g. sticking due to inadmissible solids entrainment, clogging, gas entrainment etc.) the cooling flow can be interrupted and, as a result, an inadmissible temperature rise may occur. Provide appropriate monitoring facilities. See [Section 5.6](#).

For safe pump operation, we recommend a flow rate of 0.3 to 1.1 Q_{opt} . If the pump is operated outside this range, it must be ensured that the max. admissible flow rate according to the pump characteristic curve is not exceeded and that the max. admissible operating temperature according to [Section 2.6.7](#) is observed.

If the flow rate is too high, the differential pressure upstream and downstream of the plain bearings could fall so much that a lack of lubrication or dry-running may occur.

If the flow rate is too low, the medium may heat up so much owing to the fluid friction that the max. admissible surface temperature of the relevant temperature class is exceeded.

Overloading, overheating, non-observance of the design data or the incorrect selection of the magnetic drive can lead to the decoupling of the inner and outer magnet assemblies. As a result, eddy currents may be induced on the inner and outer magnet assemblies and an inadmissible temperature rise may occur.

The situation is to be remedied by providing appropriate monitoring facilities. See [Section 5.6](#).

The plant NPSH value (NPSHA) should be minimum 0.5 m higher than the NPSH value of the pump (NPSHR) to prevent a lack of lubrication or dry-running of the plain bearings.

2.6.3 Chargeable liquids



For operation with chargeable liquids with a conductivity $< 10^{-8}$ S/m inert gas must be used for flushing during evacuation if the lining of the pump is non-conductive. See [Section 6.3](#).

2.6.4 Identification



The identification on the pump relates to the pump section. A separate declaration of conformity must be provided for the shaft coupling and motor and for other attachments as well as corresponding identification.

Example of the identification of the pump section:

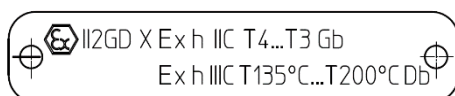

For assembling the pump with components which are not explosion-protected (e.g. motor, shaft coupling), it is recommended to mask or remove the "potentially explosive" identification from the pump component and, if necessary, from other accessories.

In this case the declaration of conformity applies without ATEX identification.

For surface temperatures that mainly depend on the operating conditions of the pump, DIN EN ISO 80079-36 Chapter 11.2 f) and g) state that no temperature class or temperature may be specified. In this case, the identification must include temperature range identification (e.g. T4 ... T3 for gas or for dust D135 °C ... T200 °C).

The temperature class must be determined by the operator in accordance with [Section 2.6.7](#) "Temperature Limits".

2.6.5 Check of the direction of rotation



If there is also a risk of explosion during the installation phase, the check of the direction of rotation must under no circumstances be conducted by briefly switching on the unfilled pump in order to prevent an inadmissible rise in temperature at the plain bearings.



We recommend you to only perform a check of the direction of rotation with the coupling disengaged or with a rotating field instrument. See also [Section 6.1.2](#).

2.6.6 Mode of operation of the pump

The pump may only be started with the suction side shut-off element fully opened and the discharge side shut-off element slightly opened. Start-up against a closed check valve is also possible. The discharge side shut-off element is to be regulated to the operating design point directly after run-up. See also [Section 5.4.1](#).

Operation with closed shut-off elements in the suction and/or discharge lines is not permitted!



There is a risk that even after a short time high surface temperatures on the pump housing may occur owing to rapid heating of the liquid in the pump interior.



A rapid rise in the pressure inside the pump involves the risk of overloading to the point of bursting.



The pump must not be in operation in the unfilled or partially filled state (dry running). This results in serious damage to the pump and additional risks to the environment can arise.



Dry-running cannot only occur with an insufficiently filled interior but also in the event of high gas contents in the liquid medium

Operation of the pump outside the admissible operating range may also lead to dry-running (e.g. due to evaporation in the interior).

2.6.7 Temperature limits



In normal operating mode the highest temperatures are to be expected at the contact point shaft seal/shaft (only with oil bath lubrication), on the inner races of the ball bearings and at high medium temperatures on the surface of the pump housing.



We would like to point out that, under extreme operating (medium temperature > 160°C) and ambient conditions (ambient temperature >30 °C), temperatures of over 130°C may arise on the surface of the pump housing.

In the case of media >40° C the surface temperature of the pump housing is generally lower than the temperature of the medium as the plastic lining acts as insulation.

Table 1

Temperature class acc. to. DIN EN ISO 80079-36	Limit value of the pumped liquid temperature			
Lining material	PE-UHMW	PFA/PTFE		
Can material ⁴⁾	CFK-F	CFK-F	CFK-H	CFK-Polyimid
T4 (135 °C)	90 °C ¹⁾	125 °C ^{1) 2)}	125 °C ^{1) 2)}	125 °C ^{1) 2)}
T3 (200 °C)	90 °C	150 °C	180 °C	180 °C ³⁾

- 1) Long life grease lubrication: no restriction.
Oil bath lubrication: standard version with shaft seal
T4 only applies to operation up to and including 50 Hz,
T3 above 50 Hz
T4 labyrinth seal (special design)
- 2) The limit values specified for the temperature of the medium at the pump inlet are determined for the most unfavourable case (high speed, low flow, low heat capacity of the medium, ...). Under favourable operating conditions the limit values specified may be increased by up to 5 K after consultation with the manufacturer.
- 3) Consult the manufacturer for higher limit values.
- 4) The can material has been list in the data sheet.

The plant customer must ensure that the prescribed operating temperature is observed. The maximum admissible temperature of the liquid medium at the pump inlet depends on the temperature class and the selected lining material required in each case.

It is only possible to observe the temperature class T4 with oil lubrication with the standard rotary shaft seal during operation up to and including 50 Hz. T3 applies to operation above 50 Hz with the standard rotary shaft seal.

The special version with a labyrinth seal permits operation in T4 regardless of the speed.



If the pump is heated (e.g. heating jacket), it must be ensured that the temperature classes prescribed in the annex are observed.

The not heated pump surface must have free contact with the environment.



When operating the pump, make sure that an excessive deposit of dust is avoided (possibly regular cleaning). This prevents the pump surface from heating to above the admissible temperature.

Table 1 below indicates the admissible medium temperature, depending on the pump design, as a function of the temperature class in accordance with EN 13463-1.

2.6.8 Maintenance



For safe and reliable operation, it must be ensured with regular inspection intervals that the unit is properly serviced and kept in a perfect technical condition.

Example: Functioning of the ball bearings. The mode of operation and operating conditions largely determine the actual service life that can be attained.

Regular checks of the bearing pedestal area can prevent excessive temperatures due to hot-running ball bearings, collision of the drive magnet assembly against the lantern or even defective bearing seals. See **Section 7.2**.

In regard to media containing solids, the maintenance intervals must be set by the operator in accordance with the conditions of operation.

If auxiliary systems (e.g. external flushing, cooling, heating) are installed, a check must be made to see whether monitoring facilities are required to safeguard their operation.

2.6.9 Electric peripheral equipment



Electric peripheral equipment, e.g. pressure, temperature and flow sensors etc. must comply with the prevailing safety requirements and explosion protection provisions.

3 Transport, storage and disposal



The pump or the unit must be transported properly. It must be ensured that during transport the pump/unit remains in the horizontal position and does not slip out of the transport suspension points.

A pump or motor can be suspended from the ring bolt provided for this purpose.

The suspension points are not suitable for transporting a complete unit, i.e. pump with base plate and motor.

In this case, the slinging points for the ropes on the base plate are to be used. See **Fig.1**.

The slinging ropes must not be attached to free shaft ends or to the ring bolt of the motor.

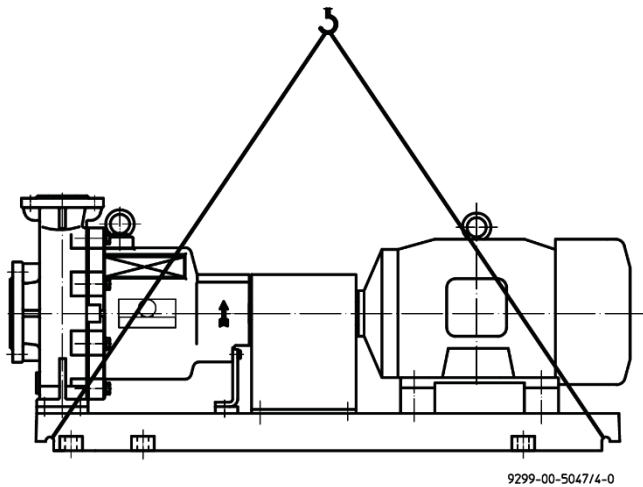

Fig. 1

Directly after receipt of the goods, the consignment must be checked for completeness and any in-transit damage.

Damaged pumps must not be installed in the plant.



When unpacking magnetic drives as single parts, the relevant notes in **Section 7.5.2** must be observed.

Handle goods carefully to prevent damage.

Flange covers serve as protection during transport and must not be removed.

If the unit is not installed immediately after delivery, it must be put into proper storage.

The product should be stored in a dry and vibration-free, well ventilated room at as constant a temperature as possible.

Elastomers are to be protected against UV light.

In general, a storage period of 10 years should not be exceeded. An admissible storage period of 4 years applies to elastomers made of NBR.



If magnetic drives are stored as single parts, the relevant notes in **Section 7.5.2** are to be observed.

In the case of **prolonged storage** conservation agents on machined component surfaces and packing with a desiccant may be necessary.

3.1 Return consignments



Pumps which have conveyed aggressive or toxic media must be well flushed and cleaned before being returned to the manufacturer's works.

It is **imperative** to enclose a **safety information sheet / general safety certificate** on the field of application with the return consignment.

Pre-printed forms are enclosed with the installation and operating manual.

Safety precautions and decontamination methods are to be mentioned.

3.2 Disposal

Parts of the pump may be contaminated with medium which is detrimental to health and the environment and therefore cleaning is not sufficient.



Risk of personal injury or damage to the environment due to the medium or oil!

Wear protective clothing when work is performed on the pump.

Prior to the disposal of the pump:

Collect any medium, oil etc. which has escaped and dispose of it in accordance with the local regulations.

Neutralise any medium residues in the pump.

Separate pump materials (plastics, metals etc.) and dispose of them in accordance with the local regulations.

4 Product description

The housing dimensions, nominal ratings and technical requirements of the pump series MNK correspond to ISO 2858 / DIN EN 22858 / ISO 15783 / DIN ISO 5199. The technical requirements of the VDMA 24279 are satisfied.

The **sectional drawing** shows the design of the pump. See **Section 9**.

All components which come into contact with the medium are either plastic-lined or made of other resistant materials, e.g. silicon carbide.

The housing **100** consists of a metallic shell with a plastic lining.

The bearing bushes **545** are secured against turning in the plain bearing pedestal.

The bearing sleeves **529/1** are in the impeller, resp. **529/2** in the inner magnet assembly secured against turning.

The bearing bushing **529/2** has an additional form closure in the "lemon shape" along with the anti-twist device. This increases the transmissible torque.

The distance ring **504** prevents the bearing sleeves from "moving".

The can **159** is made of CFK (high-resistance, carbon fibre composite material). It is protected against the medium by a can insert **158** made of resistant plastic.

Only oil bath lubrication

The bearing pedestal **330** contains radial ball bearings **321/1**, **321/2**, which are lubricated by an oil bath. This oil bath is sealed by means of the shaft seals **421/1**, **421/2** and the o-rings **412/1**, **412/5**.

Special designs:

A **vacuum-proof can unit** is produced by gluing the can to the can insert.

The **flushing flow** flows through the bores in the plain bearing pedestal into the can chamber.

From there it is returned into the housing through the plain bearings.

The can chamber is also **vented** and **evacuated** through the bores in the plain bearing pedestal.

Additional information is provided by the **brochure**.

5 Installation

5.1 Safety regulations



Equipment which is operated in potentially explosive areas must satisfy the explosion protection regulations.



People with a pacemaker are at risk from the strong magnetic field of the magnetic drive. It may be life-threatening for them to stay at a distance of less than 500 mm to the pump.

5.2 Installation of pump / unit

The structural work must be prepared in accordance with the dimensions in the installation drawing.

Method of installation: on a grouted base plate and firm foundation

Align base plate on the ground foundation.

Insert foundation bolts and grout base plate.

Do not tighten the foundation bolts uniformly and firmly until the mortar has set.

Other possibilities of installing the pump are:

4-point installation

4-point installation with base plate.



As soon as additional installations are mounted, the stability of the entire unit installed without a foundation must be checked.

5.3 Alignment of pump-coupling-motor



The following information is of a general nature. If necessary, special notes of the coupling and motor manufacturer are to be observed.



After attachment of the base plate on the foundation and connection of the pipes, the alignment of the coupling must be carefully checked and, if necessary, the unit re-aligned with the motor.

A coupling check and possible re-alignment is also necessary if the pump and motor are supplied on a common base plate and aligned.

Prior to alignment undo the support bracket 183 and then tighten it without stress.

The pump is to be aligned in all directions using a spirit level (on shaft/discharge nozzle) (admissible position deviation max. 0.2 mm/m).

A distance depending on the coupling used is to be observed between the pump and motor shafts. See installation drawing.

Use supports in the direct vicinity of the bolts foundation/base plate.



Ensure that the unit cannot be started during work without the coupling guard.

5.4 Piping

Before the pump is installed, both the suction and supply lines as well as the discharge line are to be cleaned.

Dirt or damage to the sealing surfaces is best avoided if the flange covers remain on the flanges until just before installation.

Use flange gaskets suitable for the medium.

The screw tightening torques in **Section 1.1** are to be observed for tightening the flange screws.

5.4.1 Nominal size

The operating design point of a centrifugal pump lies at the intersection of the pump curve and the pipe curve, see **Fig. 2**. The pump curve is provided by the pump manufacturer. The pipe curve is determined using diagrams or PC programs.

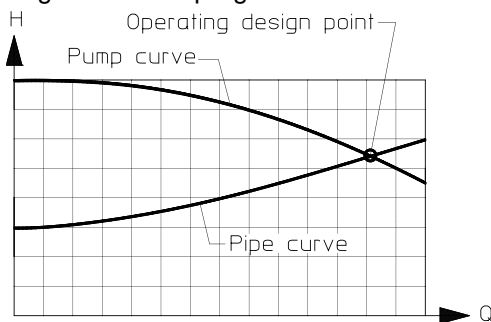

9299-00-5009_en/4-0

Fig. 2

Under no circumstances can the nominal size of the piping be derived from the connected nominal size of the pump.

The pipe nominal size can also be determined using the flow rate as a rough guide.

$$v \text{ (m/s)} = \frac{Q \text{ (m}^3\text{/s)}}{A \text{ (m}^2\text{)}}$$

The velocity in the suction line should not exceed 2.0 m/s and 5.0 m/s in the discharge line.

When determining the suction line nominal size, the NPSH value (net positive suction head) must also be observed. The **NPSHR value** required for the pump is specified in the data sheet.



The NPSHR available in the plant should be at least 0.5 m higher than the NPSHR required for the pump. Otherwise, this will lead to a drop in the delivery head, cavitation or even failure of the pump.

5.4.2 Nozzle loads

The pump can be subjected to nozzle loads in accordance with ISO 5199.

Changes in the length of the piping caused by temperature are to be allowed for by appropriate measures, e.g. the installation of expansion joints.

5.4.3 Suction line

The suction lines must always be laid on a rising gradient towards the pump. Otherwise, gas bubbles may form which considerably reduce the suction line cross section. Eccentric transition elements must be installed between different pipe diameters.

Valves which disrupt the course of flow should not be installed directly upstream of the pump.

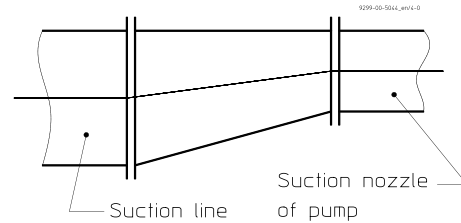

Fig. 3

5.4.4 Supply lines

Supply lines should vent towards the reservoir and are therefore to be laid with a constant downward gradient towards the pump. Should the piping internals upstream of the pump be horizontal, a low point can, of course, be located upstream of these internals. From here the pipe is then laid with an upward gradient to the pump so that the gas bubbles which form here can escape through the pump.

Valves which disrupt the course of flow should not be installed directly upstream of the pump.

5.4.5 Discharge line

Do not arrange the shut-off valve directly above the pump but initially provide a transition section.

The discharge nozzle velocity of the medium can – if necessary – be reduced.

5.4.6 Venting and draining

Venting can take place into the discharge line or upstream of the discharge valve.

A venting line can also be used as a bypass, drain or flushing line.

The pump housing is fitted with a drain connection as a standard feature. Optionally, the drain bore can be drilled. Boring template see **Section 10.1**.

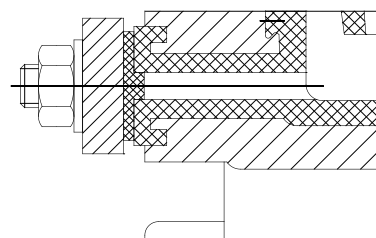

9299-00-5081/4-0

Fig. 4

5.5 Pipe fittings

The following pipe fittings are available from Richter on request:

- Shut-off valves
- Check valves
- Sight glasses
- Priming vessels
- Strainers
- Pressure gauges

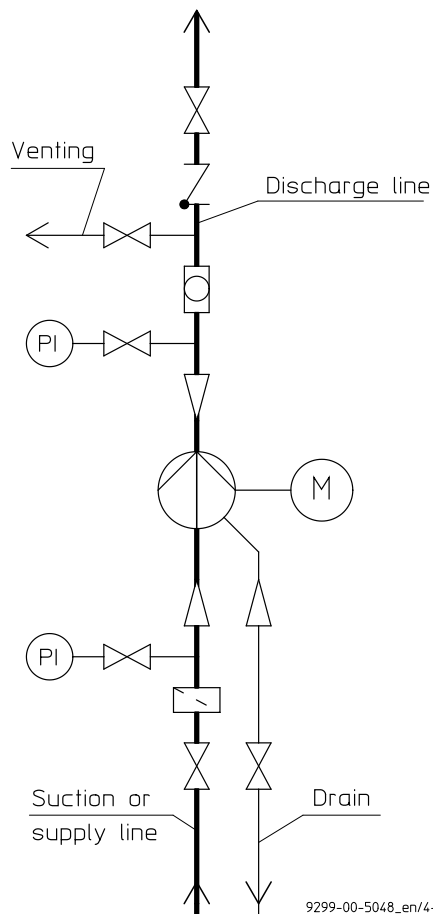

Fig. 5

5.6 Monitoring facilities



Appropriate monitoring facilities are to be recommended, depending on the requirements placed on operational safety and availability of the unit.

Richter provides information on request and can supply:

- Flow meters
- Filling level indicators
- Motor load monitors
- Temperature monitors
- Ball bearing monitors
- Can monitors
- Leak monitors
- SAFERUN® Condition Monitoring System

You can obtain the publications "Safe Operation of Magnetic drive Pumps" and "The Operation of Centrifugal Pumps without NPSH Problems" on request.

5.7 Drive

The power consumption of the pump at the operating design point is specified in the data sheet and works certificate. If the operating design point was not known when the pump was dispatched, the power consumption can be read off the appropriate performance curves. The max. density, the max. viscosity and a safety margin are to be allowed for.

Care must be taken when selecting the motor size to ensure that the excess power is not too great. During start-up the magnetic drive could otherwise stop.

The magnetic drive rating at the nominal speed of 2900 rpm is given in the pump data sheet.

If the motor rating exceeds this magnetic drive rating – at pump speed –, it is necessary to check for any stoppage of the magnetic drive.

This also applies if the required drive rating exceeds 80% of the magnetic drive rating – at pump speed.

Consult Richter if necessary.

Different operating data can be achieved without changing the pump through the use of different speeds, e.g. by means of a frequency converter.

The pump with base plate and motor is illustrated in the **installation drawing**.

The **operating manual of the motor manufacturer** must be observed.



A motor with a valid ATEX certificate is to be used if employed in zone 1 and 2.

5.8 Coupling

If one coupling half engages with the other, the claw section is normally to be mounted on the pump shaft and the coupling half with the smooth end face on the motor shaft.

Observe the operating manual of the coupling manufacturer.



A coupling with a valid ATEX certificate is to be used if deployed in zone 1 and 2.

Regulations exist, e.g. for the following details:

- Arrangement of the coupling halves
- Max. bore diameter
- Max. transmitted power
- Spacing of the coupling halves
- Maximum values for offset and angular misalignment.

Should the pump housing and motor remain on the base plate for repair work, a spacer type coupling is required.

5.9 Final check

Check the alignment of the coupling again in accordance with **Section 5.3**.

It must be possible to easily turn the unit at the coupling by hand.

5.10 Coupling guard

The pump may only be operated with a coupling guard in accordance with the accident prevention regulations.



It should be ensured that the coupling protection used either consists of non-sparking material or fulfills the impact resistance test required by DIN EN ISO 80079-36 without any problem.

Richter offers both versions.



The operator must ensure that, after the coupling protection has been mounted, the requirements of the machine guideline are fulfilled.

6 Commissioning/Shutdown

6.1 Initial commissioning

Normally, the pumps have already been test-run with water. Unless special agreements have been made, there could still be residual amounts of water in the pump. This must be noted in view of a possible reaction with the medium.

Long life grease lubrication

The ball bearings are greased for life. Regreasing is not possible and not necessary.

For service lives, see **Section 7.2**.

Oil bath lubrication

Pour in oil into the bearing pedestal!

For procedure and the oil grade, see **Sections 7.2 and 7.8.5**

6.1.1 Filling the pump housing

Check to see whether the screws on the suction flange, discharge flange, housing flange and drain flange are tightened. When retightening the housing screws, make sure that the support bracket is undone. Otherwise, the pump could be deformed.

For screw tightening torques see **Section 1.1**.

Open the suction line fully so that the medium can flow into the pump.

Open the discharge valve so that the air in the pump can escape.

If air cannot be vented into the discharge line, e.g. a drop in pressure in this line is not permitted, venting must be performed upstream of the discharge valve.

5.11 Electric connection

The operator is obligated to connect the assembly in accordance with existing regulations 8 (IEC, VDE, etc.).



Allow only a trained electrician to perform the electrical connection.

Compare the existing mains voltage with the indications on the motor's manufacturer's nameplate and choose a suitable circuit.

A motor protection device (motor-circuit switch) is urgently recommended.



Danger of explosion if the electrical installation is incorrect.



In areas at risk of explosion, IEC 60079-14 must also be observed for the electrical installation.

If the pump is mounted on a base plate, ensuring electrical conduction through the use of a chopper disk or contact disk on the housing foot and support leg.

The assembly must be grounded in accordance with currently effective regulations, for example, on the base plate.

Monitor the venting operation until no air but only liquid emerges.

Turn the pump shaft at the coupling several times.

Monitor the venting operation again until no more air emerges.

Close the discharge valve again until only the minimum flow rate is obtained after the motor has been started.



6.1.2 Start-up

Check to see whether the pump shaft can be readily turned by hand.



Check the direction of rotation of the motor with the coupling disengaged or with a rotary field instrument.

As viewed from the motor, the direction of rotation of the pump is clockwise. See also the direction of rotation arrow of the pump.



The pump must not run dry during the check of the direction of rotation.

Check alignment of the coupling.

Mount coupling guard.



The pump must be completely filled with liquid. The maximum admissible flow rate must not be exceeded.



Otherwise the plain bearings can run dry in both cases.

Switch the motor on.

Set the desired flow by opening the discharge valve.



When the motor is running but the pump is not conveying, this means that the magnetic drive has stopped.

Switch motor off immediately in order to prevent overheating of the magnet assemblies.

Then proceed as follows:

Close discharge valve down to the position "minimum flow rate".

Start motor again.

If the magnetic drive stops again, look for the cause.

6.2 Operating limits



The operating limits of the pump/unit in terms of pressure, temperature, power and speed are entered in the data sheet and it is imperative to observe them!

6.2.1 Abrasive media



If liquids with abrasive constituents are conveyed, increased wear at the pump is to be expected. The inspection intervals should be reduced compared with the usual times.

6.2.2 Min./max. flow rate

The operating range generally recommended lies at 0.3 Q_{opt} to 1.1 Q_{opt} . Consult the manufacturer for operation outside this range and observe [Section 2.6.2](#).

6.3 Shutdown

Close discharge valve down to the position "minimum flow rate"

Switch motor off.

Close discharge valve completely.

Only close the suction line if the pump is to be evacuated or dismantled.



For all work on the machine, make sure that the motor cannot be inadvertently switched on.



If the pump is to be evacuated or flushed, observe the local regulations.



If the pump has been operated with a chargeable liquid, it must be filled with inert gas (e.g. nitrogen) to prevent an explosive atmosphere.

It is recommended to wait one hour before the pump is dismantled from the plant to permit static peak charges to be eliminated.

These measures are not necessary with pumps with a conductive plastic lining.

If the pump is returned to the manufacturer's, clean the pump very thoroughly.

See also [Section 3.1](#).

6.4 Restarting

When the pump is restarted, it must be ensured that all the relative steps as described in [Section 6.1](#) are repeated, depending on the progress of the shutdown operation.

6.5 Improper operations and their consequences (examples)



Inadmissible modes of operation, even for a short time, can result in serious damage to the unit.

In connection with explosion protection, potential sources of ignition (overheating, electrostatic and induced charges, mechanical and electric sparks) may result from these inadmissible modes of operation; their occurrence can only be prevented by adhering to the intended use.

Pump is started up without medium :

The plain bearings in the pump may be destroyed.

Other pump components may be destroyed due to overheating.

Operation with magnetic drive stopped:

If no heat is dissipated, damage to the inner and drive magnet assemblies may occur.

Suction line not opened or not opened fully :

Pump is cavitating – material damage to pump and plain bearings

Pump does not attain the required delivery head or flow rate.

Pump may be destroyed due to overheating.

Discharge valve closed too much :

Pump may be destroyed due to overheating.

Axial thrust too great.

Discharge valve opened too much :

Pump can cavitate. Particularly severe with an empty discharge line.

Risk of pressure surge.

Possible damage to the plain bearings.

Magnetic drive may stop.

Motor may be overloaded.

Suction valve and discharge valve closed :

Destruction due to rapid overheating and sharp rise in pressure.

Control of the pump with the suction valve :

Cavitation – the volume may only be regulated on the discharge side.

Overrun of the admissible gas content:

The flow may stop.

Switch pump and vent off for renewed conveyance.

Make sure that the gas content is not exceeded, as described in the intended use.

7 Maintenance

7.1 Screw connections of the housing

After initial loading by the operating pressure and operating temperature the tightening torques of all connection screws must be checked at the following points:

housing flange

suction flange

discharge flange

See also **Section 6.1.1, para. 1.**

Other inspections are to be performed regularly, depending on the operating requirements.

7.2 Bearing pedestal



The temperature of the bearing pedestal is not to exceed more than 70 °C and under no circumstances 80 °C.

If higher temperatures do occur, call in qualified staff without delay. If this is not possible, the pump must be shut down and taken out of service.

In many cases a vibration measurement is recommended to detect bearing wear in good time.

7.2.1 Long life grease lubrication

Grease-filled rolling bearings of type 2RS are fitted as standard. The grease based on polyurea thickener and ester oil has the designation WT. The permissible temperature range lies between -40°C and +160°C.

The roller bearings are designed for a service life L_{10} of >35,000 hours. **The service life of the grease filling guaranteed by the bearing manufacturers is shown in the following table. Depending on the degree of contamination, the service life of the grease is reduced.**

Size	Bearing size > Service life
Group 1.1	6206-2RS WT / 35000 hr*
Group 1.2	6308-2RS WT / 35000 hr*
Group 1.3	6308-2RS WT / 35000 hr*
Group 2	6211-2RS WT / 35000 hr*

* at bearing temperature <70 °C

If the pump is serviced, it is recommended to also replace the bearings as a precaution.



In potentially explosive works it is advisable to monitor the condition of the ball bearings

7.2.2 Oil bath lubrication

We recommend a mineral oil with the following characteristics for an expected bearing temperature of about 70 °C:

Viscosity index : appr. 85

Kinematic viscosity at 40 °C : appr. $40 \frac{\text{mm}^2}{\text{s}}$

A fully synthetic gear oil to ISO VG 220 is to be used for temperatures below – 20

Replacing the bearings: The ball bearings are designed for an L_{10} service life of >35.000 hours.

We recommend 35.000 working hours respectively every 4 years a change of bearing should be made.

Oil changes: 1x per year at bearing temperatures of about 70 °C.

At higher temperatures more frequently in accordance with the regulations.

When the pump is serviced, it is recommended to replace the bearings and shaft seals as a precaution and to pour in fresh oil.

Oil level check: The oil level is to be regularly checked on the constant level oiler **638/1** to ensure safe operation.

It must be ensured that there is always oil in the constant level oiler; it must under no circumstances be completely drained.



In potentially explosive works it is advisable to monitor the condition of the ball bearings

If there is a suspicion that splash water could have entered the bearing pedestal, the oil must be replaced immediately. Even small amounts of water in the oil reduce the service life of the ball bearings to a fraction of the normal service life.

7.3 Cleaning

Care must be taken when cleaning the pump to ensure that it is not exposed to a strong water jet. The ingress of water into the bearing pedestal will substantially impair bearing lubrication.

7.4 Stand-by pumps

If a pump is on stand-by, it is to be started up from time to time. Regularly turn the shaft by hand in the direction of rotation.

This operation is to be performed more often for pumps which are exposed to very strong vibrations from the plant.

When dismantling the pump from the plant, drain it, thoroughly clean it, seal with flange covers and store in accordance with the instructions.

7.5 Notes on dismantling

All repair and maintenance work is to be performed by skilled staff using appropriate tools and original spare parts.

Is the necessary **documentation** available?

Has the pump been taken out of operation, evacuated and flushed correctly? See also **Section 6.3**.

If no new assembly is performed immediately after dismantling, the plastic and ceramic components in particular must be stored carefully.

7.5.1 Protective clothing



Even if the pump has been properly evacuated and flushed, residue of the medium may still remain in the pump, e.g. between sealing surfaces or in the bearing seats or in the can or the can insert.

Plastic components may absorb medium which gradually emerges from the material after flushing.



Proper protective clothing is to be worn.

Protective clothing is also to be worn even if only the bearing pedestal is to be removed. Medium may have penetrated the lantern chamber through the can.

7.5.2 Magnetic fields



Caution ! Strong magnetic fields

Risk during dismantling and in the vicinity of magnetic drives as single parts.

Remove loose parts and other magnetisable metals from the work bench. They could otherwise be attracted: **Risk of accident!**

Place any tools needed at a safe distance.

Keep electronic equipment and measuring instruments at a distance. In cases of doubt consult the equipment manufacturer.

Hold magnetic drives as single parts firmly or secure. Otherwise they could be attracted, for example, by a vice: **Risk of accident!**



People with an artificial pacemaker
Keep torso **at a minimum distance of 500 mm**.

For safety's sake, a distance of 150 mm should be observed for watches, electric data carriers, data carriers with magnetic strips etc.

7.6 Dismantling

There are two possibilities for dismantling:

1. Dismantling the complete pump from the plant.
2. Dismantling the complete slide-in unit as the pump housing can remain in the plant connected to the piping.

Dismantling of the complete pump is described here.

If the coupling installed is a spacer-type coupling, the motor can also remain in the plant.

Undo support bracket **183** from the base plate

Undo housing screws **901/2, 552/1**

Remove entire slide-in unit



If the housing remains in the plant, leave the housing gasket in the centering to protect the housing sealing surface.



**Caution! Magnetic forces!
Risk of accident !**

Axial forces are produced when the plain bearing pedestal is pulled out of the bearing pedestal. These forces diminish again abruptly after it has been removed.

The operating torque of the magnetic coupling installed is specified on the **type plate**.

7.6.1 Dismantling the slide-in unit

Secure slide-in unit on the work bench or a work top.

Pull the plain bearing pedestal **339** out of the bearing pedestal.



**Caution! Magnetic forces!
Risk of accident !**

If necessary loosen the centering of the plain bearing pedestal using a rust dissolver and levers.



It is imperative to use clamping jaws with a rubber surface.

Clamp the plain bearing pedestal **339** with the sealing surfaces in a vice.

Undo the impeller **230** and inner magnet assembly **859** with a strap wrench. **Right-hand thread !**

Pull parts out of the plain bearing pedestal **339** or off the pump shaft **211**.



Make sure that no parts of the plain bearing fall. Silicon carbide is easy to break.

Keep bearing sleeves **529** and bearing bushes **545** in pairs which belong together.

Clamp pump shaft **211** with the flat pivot point in a vice. Use **smooth clamping jaws**.

Undo impeller **230** or inner magnet assembly **859** (depending on which part has remained on the pump shaft).

If the bearing bushes **545** have to be removed from the plain bearing pedestal, a Richter jig is best suited for this purpose. See assembly aids in **Section 10.3**.

To dismantle the can **159**, can insert **158**, intermediate ring **509** and support ring **518**, loosen the centering of the support ring **518** on the side recesses in the bearing pedestal **330**.

Pull parts out of the bearing pedestal **330**.

Only separate can **159** and can insert **158** if one part has to be replaced. If separation is not possible, the unit must be cooled to approx. 5 °C.

In the case of a vacuum-proof design the can insert is glued to the can. Separation is not possible without destroying the can.

In the case of a can with a can monitor using a flexible p.c. board, dismantling is possible. We recommend you, to have the reassembly be performed at the manufacturer's.

7.6.2 Dismantling the drive unit Long life grease lubrication

Remove circlip **932/3** on the motor side.

Remove rear bearing cover **361**. Use groove for dismantling.

Remove circlip **932/2**.

Press drive shaft **213** with drive magnet assembly **858** out of the bearing pedestal.

Remove radial ball bearings **321/1**.

Remove second circlip **932/1**.

Remove distance sleeve **525** and second radial ball bearing **321/2**.

Dismantling can be checked using the sectional drawing in **Section 9.2** and the components available.

7.6.3 Changing the radial ball bearings Long life grease lubrication

To change the radial ball bearings **321**, perform dismantling as described in **Section 7.6**.

Pull the plain bearing pedestal **339** out of the bearing pedestal. See **Section 7.6.1**.

The plain bearing pedestal with impeller, inner magnet assembly and pump shaft need not be dismantled.

The rest dismantling see **Section 7.6.2**.

Change radial ball bearings **321**.

Assembly as described in **Section 7.8**.

7.6.4 Dismantling the drive unit Oil bath lubrication

Remove hex. screw **901/4** and drain oil.

Remove hex. socket screw **914/1** with spring washer **934/2** for the bearing cover. For this purpose assembly bores are provided in the drive shaft **213** for a hex. socket screw key.

Remove circlip **932/3** on the motor side.

Remove rear bearing cover **361** with shaft seal **421/1** and O-ring **412/1**. Use groove for dismantling.

Remove circlip **932/2**.

Press the drive shaft **213** with drive magnet assembly **858** out of the bearing pedestal.

Remove radial ball bearings **321/2** from the bearing pedestal.

Remove circlip **932/1**.

Remove distance sleeve **525**, radial ball bearings **321/1**, O-ring **412/5** and bearing cover **360** using an extractor.

Dismantle drive magnet assembly **858** and drive shaft **213**.

If necessary, press the shaft seals **421/1** and **421/2** out of the bearing cover **360** and rear bearing cover **361**.

Dismantling can be checked using the sectional drawing in [Section 9.2](#) and the components available.

7.6.5 Changing the radial ball bearings Oil bath lubrication

To change the radial ball bearings **321**, perform dismantling as described in [Section 7.6](#).

Pull plain bearing pedestal out of the bearing pedestal.
See [Section 7.6.1](#).

The plain bearing pedestal with the impeller, inner magnet assembly and pump shaft need not be dismantled.

For further dismantling, see [Section 7.6.2](#).

Change radial ball bearings **321**.

It is recommended to also change the shaft seals **421** when the bearings are being replaced.

Assembly as described in [Section 7.8](#).

7.6.6 Changing the temperature sensor PT 100 at the plain bearing pedestal

The temperature sensor PT 100 is available in one-piece and two-piece version.

one-piece

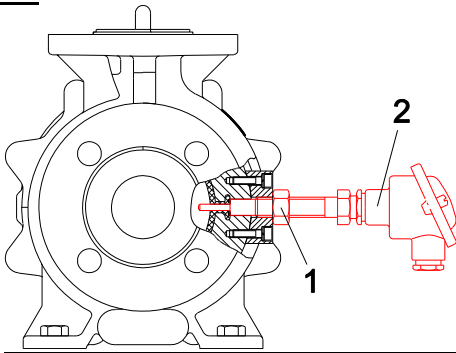

In the one-piece version the complete sensor **2** has to be removed from the housing.



Caution!
leakage.

Loosen the nut **1** and remove the complete sensor **2** from the housing.

two-piece

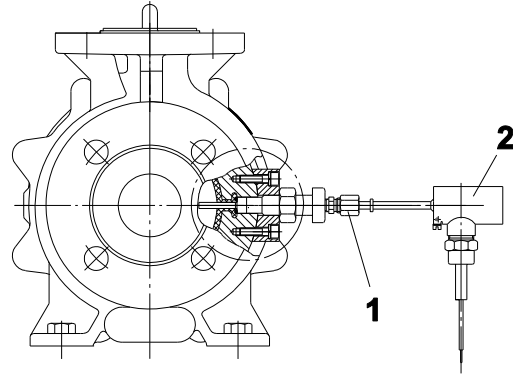

In the two-part version the sensor head **2** can be removed alone.

Loosen the nut **1** and remove the sensor head **2**.

7.7 Notes on assembly

Use original spare parts. See also [Section 2.4](#).

Do not use any defective parts.

Has the pump been shut down, drained and flushed in accordance with the regulations?

See also [Section 6.3](#).

Apply Anti-Seize-Special assembly paste (e.g. from Weicon) to fitted surfaces (not stainless steel parts).

The thread in the impeller **230**, the inner magnet assembly **859** and on the pump shaft **211** must not be greased as otherwise no optimum glued connection is possible.

Install plain bearings in pairs as supplied or stored.

Check whether all parts fit and only then assemble.

Important dimensions (centerings, bearing fits or bearing play) are to be checked prior to assembly; perform a trial assembly if required.

It is recommended to replace the housing gasket **401** during assembly.

Many metallic particles adhering to magnetic components such as the inner magnet assembly **859** and drive magnet assembly **858** must be removed prior to assembly. For this purpose simple plasticene can be used.

A complete assembly process is described in the following.

Sub-sections can be deduced from this.

See also [Section 7.5](#).

7.8 Assembly

7.8.1 Assembly of drive unit Long life grease lubrication

Assemble drive shaft **213** and drive magnet assembly **858**.

Place drive magnet assembly vertically on a suitable base.

Press new radial ball bearing **321/1** onto the drive shaft **213**, and then the distance sleeve **525**.

Insert circlip **932/1**.

Lower the bearing pedestal **330** from above onto the unit drive shaft/drive magnet assembly.

Press on second new radial ball bearing **321/2**.

Engage circlip **932/2**

Mount rear bearing cover **361**.

Insert second circlip **932/3**.

Install can insert into the can. If this is not possible, cool can insert to approx. 5 °C.

Place intermediate ring **509/1** and then support ring **518** in the bearing pedestal.

Insert the entire unit into the bearing pedestal.

7.8.2 Assembly of drive unit Oil bath lubrication

Screw hex. screw **901/4** into the bearing pedestal **330**.

Assemble drive shaft **213** and drive magnet assembly **858**.

Place drive magnet assembly vertically on a suitable base.

Insert shaft seal **421/2** into the bearing pedestal.

Insert O-ring **412/5** into the bearing pedestal groove and screw bearing cover **360** to bearing pedestal **330**. Carefully guide the bearing pedestal over the drive shaft; do not damage the shaft seal **421/2**.

Press new radial ball bearing **321/1** onto the drive shaft **213**, and then the distance sleeve **525**.

Insert circlip **932/1**.

Press on second new radial ball bearing **321/2**.

Engage circlip **932/2**

Mount rear bearing cover **361** with shaft gasket **421/1** and O-ring **412/1**.

Insert second circlip **932/3**.

Install can insert into the can. If this is not possible, cool can insert to approx. 5 °C.

Place intermediate ring **509/1** and then support ring **518** in the bearing pedestal.

7.8.3 Perform trial assembly of plain bearing pedestal with impeller, inner magnet assembly and plain bearings

Without adhesive

Without O-rings **412/3**, **412/4**

Without distance ring **504**

Without distance washers **551/1**, **551/2**

Install bearing bushes **545/1**, **545/2** and press in firmly.

Screw the inner magnet assembly **859** onto pump shaft **211** and tighten.

Push on bearing sleeve **529/2** on the rotor side and install these units in the plain bearing pedestal **339**.

Only push bearing sleeve **529/1** on the impeller side partially onto the pump shaft **211**.

Put impeller **230** onto the pump shaft **211**.

Permit the anti-torsion cams of the impeller side bearing sleeve **529/1** to engage in the grooves of the impeller.

Screw on impeller together with bearing sleeve and tighten

7.8.4 Determine thicknesses S_1 and S_2 of the distance washers 551.

The distances X and Z are given in the works certificate. See sectional drawings in **Section 9**.

X : Distance behind the impeller

Z : Axial clearance of the plain bearings

Press inner magnet assembly in the direction of the impeller.

Measure distance X_1 behind the impeller.

Press impeller in the direction of the motor.

Measure distance X_2 behind the impeller.

Thickness of the distance washer on the inner magnet assembly side:

$$S_1 = X_1 - X$$

Thickness of the distance washer on the impeller side:

$$S_2 = X - X_2 - Z$$

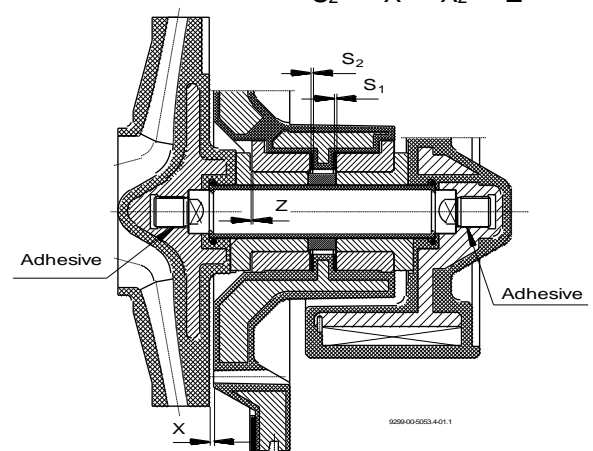

Fig. 6

Example

Figures in the works certificate (mm): $X = 2.0$
 $Z = 0.4$

Measurements during trial assembly: $X_1 = 2.5$
 $X_2 = 1.3$

$$S_1 = X_1 - X = 2.5 - 2.0 = 0.5 \text{ mm}$$

$$S_2 = X - X_2 - Z = 2.0 - 1.3 - 0.4 = 0.3 \text{ mm}$$

7.8.5 Final assembly

Dismantle trial assembly and perform the final assembly.

With the distance washers **551/1**, **551/2** in the calculated thickness

With the O-rings **412/3**, **412/4**

With distance ring **504**

With 1 drop of adhesive on each shaft thread, e.g. Loctite 243 from Loctite or an equivalent.

Only one drop of the adhesive is to be applied per thread.

Otherwise the next dismantling operation will be more difficult or no longer possible without destroying components.

The plain bearing pedestal **339** is to be installed so that the recesses for the anti-torsion insert of the plain bearing bushes **545** are arranged in a vertical position. This ensures that the flushing ducts in the plain bearing and the flushing bores in the plain bearing pedestal are located in the position (horizontal) necessary for the pump to function.

To avoid mistakes, the correct 12 o'clock position should be marked on the plain bearing pedestal with a felt-tip pen prior to assembly of the impeller and the inner magnet assembly.



Strong axial forces again arise when the completely assembled plain bearing pedestal is inserted into the bearing pedestal. Therefore, use a **Richter jig**. See assembly aids in **Section 10.2**.

Push the entire slide-in unit with housing gasket **401** into the housing **100** and screw together with housing screws **901/3** and tightening washers **552/3**.

When tightening the housing screws **901/3**, make sure that the support bracket **183** is firmly positioned. If necessary, undo support bracket, align and secure again.

For tightening torques, see **Section 1.1**.

The distance Y is also given in the works certificate. See sectional drawings **Section 9**.

Y: Distance in front of the impeller

The distance is to be observed. You can exert an influence on this with the thickness of the housing gasket.

Oil quantities:

For group 1.1 appr. 220 ml
 For group 1.2 appr. 220 ml
 For group 1.3 appr. 240 ml
 For group 2 appr. 350 ml
 Groups see **Section 1**.

See **Section 7.2.2** for the type of oil.

Procedure for filling with oil:

- Pull the plastic container out of the holder.
- Unscrew the plastic container and fill it with oil.
- Screw the plastic container shut and insert it into the holder.
- If the oil level still drops too far, add oil to the plastic container again.



Fig.7

7.9 Tests

The pumps are tested with water at the manufacturer's.

The operating data measured are documented in a **works certificate**.

If, during a test after repairs, discrepancies compared with the works certificate are discovered, the following people can be called in:

- 1) in-house pump office
- 2) The manufacturer Richter or its local agent

The following conveying data can be checked using the **pump performance curves**:

Flow rate
 Head
 Power requirement
 NPSHR

7.8.6 Fill bearing pedestal with oil

8 Malfunctions



Faults may result from inadmissible modes of operation. Such inadmissible modes of operation – even brief ones – may cause serious damage to the unit.

In connection with explosion protection, potential sources of ignition (overheating, electrostatic and induced charges, mechanical and electric sparks) can result from these inadmissible modes of operation; their occurrence can only be prevented by adhering to the intended use.

See also **Section 6.5**.

Should there be any uncertainty about the remedy to be applied, please inquire at the in-house pump office or at the pump manufacturer's.

No delivery :

Is the pump filled and vented?

Is the suction line open, vented, cleaned and correctly laid?

Is the discharge line open, vented, cleaned and correctly laid?

Is the geodetic head too high?

Is air being drawn in?

Has the magnetic drive stopped?

Flow rate too low :

Have the pump, suction line and discharge line been completely vented, filled and cleaned?

Have any strainers installed been cleaned?

Are all shut-off devices open?

Is the geodetic head too high?

Is the NPSHA too low or the NPSHR too high?

Are the pipe resistances too high?

Is the viscosity too high?

Is the direction of rotation correct?

Is the speed too low or the impeller diameter too small?

Are pump parts worn?

Gas in the medium?

Flow rate too high :

Is the geodetic head too low?

Are the pipe or nozzle resistances too low?

Is the pump speed too low or the impeller diameter too large?

Delivery pressure too high :

Is the speed too high or the impeller diameter too large?

Is the density too high?

Motor consumes too much electricity :

Is the flow rate, density or viscosity too high?

Is the speed too high or the impeller diameter too large?

Is the coupling correctly aligned?

Can the pump shaft be turned properly?

Pump does not run smoothly or creates noises :

Is the coupling well aligned?

Are the coupling elements worn?

Are the ball bearings damaged?

Are parts of the hydraulics damaged?

Is the flow rate too low or too high?

Is the impeller balanced?

Is the pump twisted?

Is there foreign matter in the pump?

Temperature of the ball bearings is too high :

How high is the actual temperature measured?

How high may it be acc. to the operating manual?

Is the running-in phase already over?

Deficient lubricant?

Over aging / wear?

Leak from the pump :

Are all screws tightened to the correct tightening torque?

Were the sealing surfaces assembled in a clean state?

Have approved gaskets been installed?

9 Sectional drawing

9.1 Legend

100	housing	551/x	distance washer
122	blind cover	552/3	tightening washer
158	can insert	554/1	washer
159	can	557/2	contact disc
183	support bracket	858	drive magnet assembly
211	pump shaft	859	inner magnet assembly
213	drive shaft	900/1	ring bolt
230	impeller	901/x	hex. screw
321/x	radial ball bearing	902/1	stud screw
330	bearing pedestal	920/1	hex. nut
339	plain bearing pedestal	932/x	circlip
361	rear bearing cover	934/1	lock washer
401	housing gasket	940/1	key
412/x	o-ring		
415/1	centering gasket		
504	distance ring		
509/1	intermediate ring		
518	support ring		
525	distance sleeve		
529/x	bearing sleeve		
545/x	bearing bush		

Additional to oil bath lubrication

360	bearing cover
411/1	seal ring
412/5	O-Ring
421/x	rotary shaft seal
638/1	constant-level-oiler
672/1	venting/filling plug
901/4	hex. screw
914/1	hex. socket screw
934/2	lock washer

9.2 MNK with grease lubrication

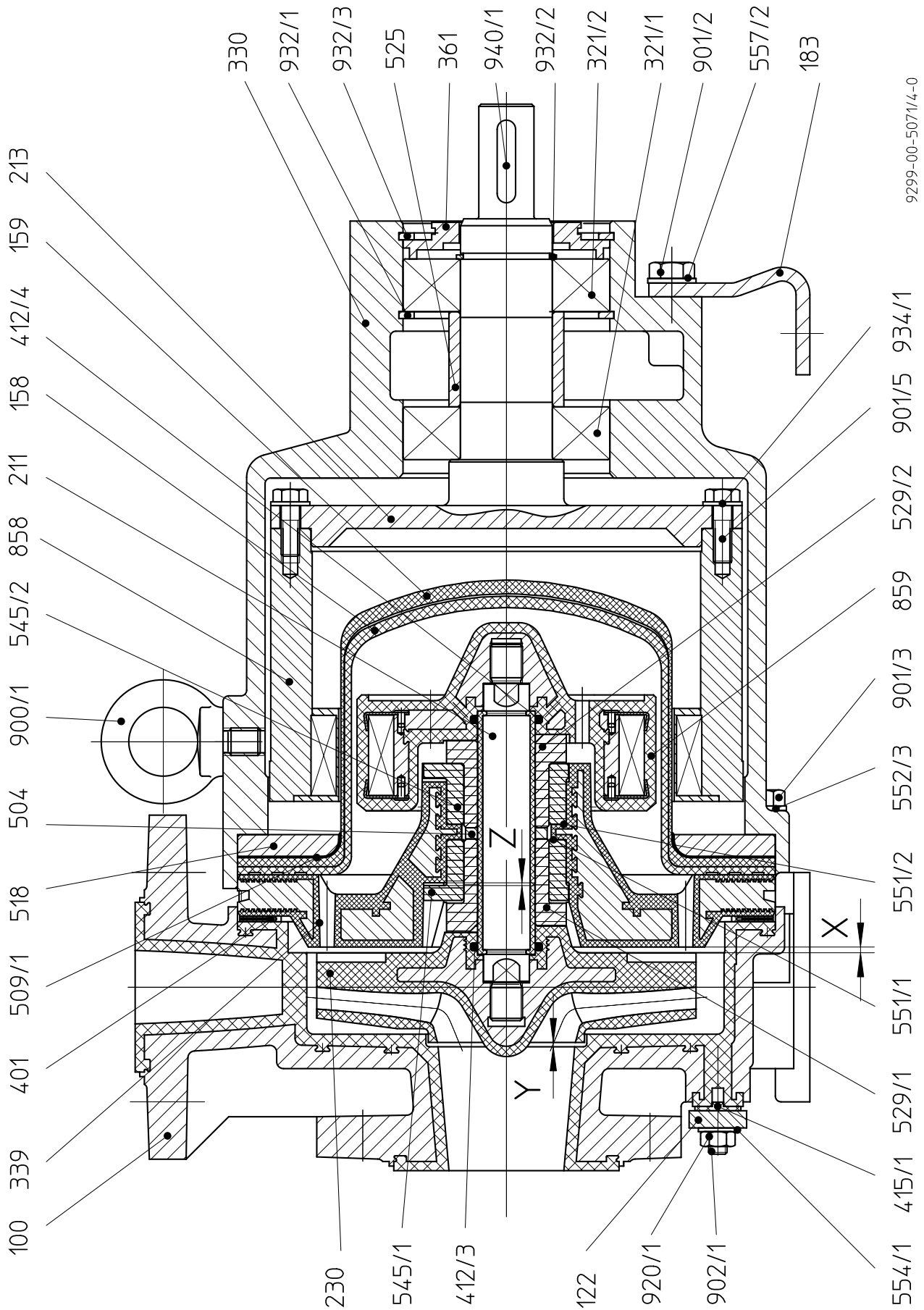

X, Y and Z see pump work certificate.

9.3 MNK with oil bath lubrication

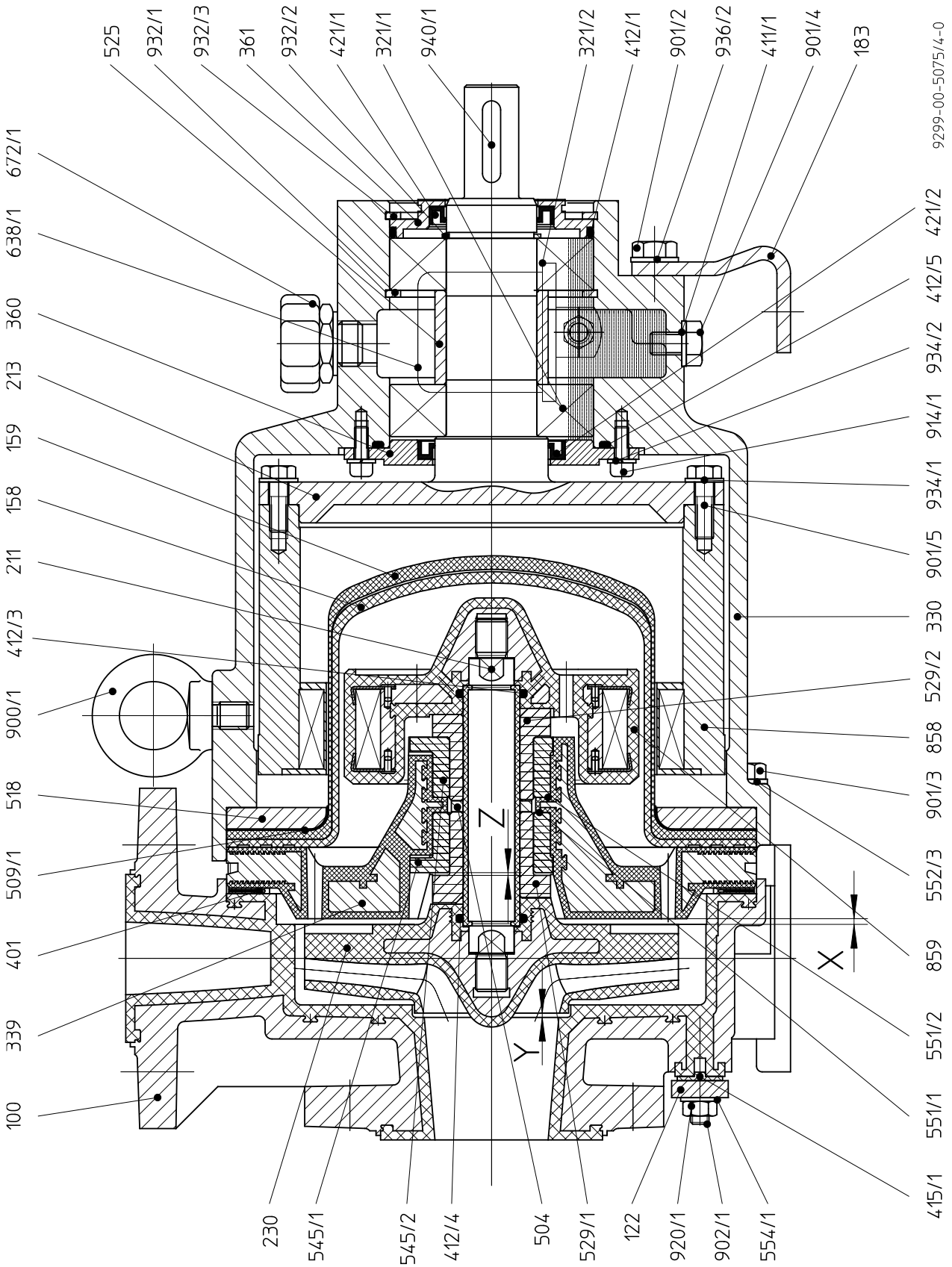

X, Y and Z see pump work certificate.

10 Assembly aids

10.1 Boring templates

Pump size	Ident.-No.
MNK 80-50-160	9217-89-1095
MNK 50-32-125	9217-89-1094
MNK 25-25-125, 25-25-160, 50-32-160 MNK 50-32-200, 65-40-200, 80-50-200 MNK 80-50-250 MNK 125-80-200, 125-100-200	9217-89-1096

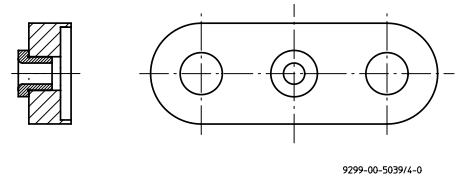

10.2 Installation device for plain bearings

Pump size	Ident. No.
MNK 25-25-125, 50-32-125	9237-89-1134
MNK 25-25-160, 50-32-160, 80-50-160	9237-89-1135
MNK 50-32-200, 65-40-200, 80-50-200	9237-89-1136
MNK 80-50-250, 125-80-200, 125-100-200	9237-89-1137

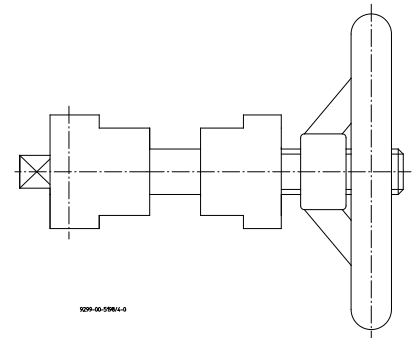

Product description:

Turning the handwheel exerts a uniform axial pressing force on the guide bushes and the plain bearings. When the installation device is pressed in, no transverse forces can arise but merely longitudinal forces, i.e. canting between the plain bearings and the plain bearing pedestal is not possible.

10.3 Pull-off device for plain bearing bushes

Pump size	Ident. No.
MNK 25-25-125, 50-32-125	9237-89-1101
MNK 25-25-160, 50-32-160, 80-50-160	9237-89-1102
MNK 50-32-200, 65-40-200, 80-50-200	9237-89-1103
MNK 80-50-250, 125-80-200, 125-100-200	9237-89-1104

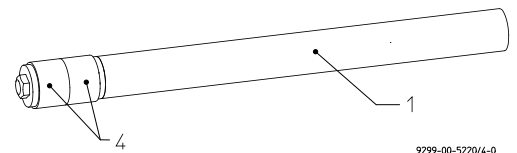

Product description

If the plain bearing bushes have to be removed from the impeller, we recommend the use of a special pull-off device. It prevents unnecessary damage to the shock-sensitive silicon carbide components through the use of suitable materials.

This device is made of malleable rubber material with a plastic handle (polyethylene).

Application

Remove plain bearing bushes:

Push the device with the rubber part in front from the suction side through the impeller.

Position the two rubber parts (4) centrally on the bearing bush.

Axially tighten the rubber parts by turning the handle (1) to the right; as a result they expand radially.

This creates a friction connection between the device and the plain bearing bush which does not damage the material.

The bearing bush can now be removed by hitting the handle centre axially.

Baureihe/Series/Série

Ausführung **Peripheralpumpe**

MPB

Design **Peripheral pump**

Construction **Pompe périphériques**



Modification techniques possibles sans réservations!
 Graphique non à l'échelle!
 Dimensions variables uniquement revêtues d'une signature!

This leaflet is subject to alteration!
 Drawing not to scale!
 Certified for construction purposes only when signed!

Technische Änderungen vorbehalten!
 Nicht maßstäblich!
 Maße nur mit Unterschrift verbindlich!

Einsatzgrenzen / operating limits

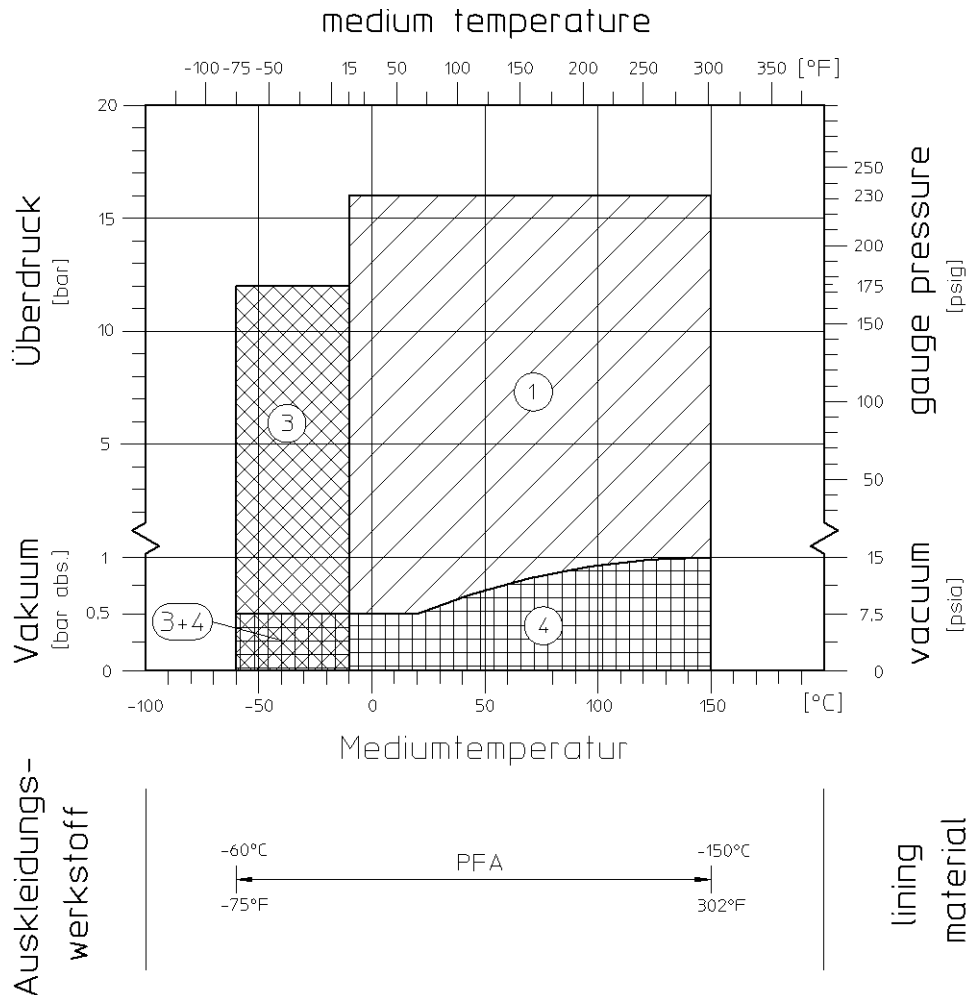

- | | |
|--|--|
| <p>1 Standard
Bei Einsatz unter ASME-Bedingungen (Sphäroguss nach A395) kann der Standardbereich auf -30 °C und 16 bar erweitert werden.</p> | <p>Standard
Application under ASME-specification (ductile iron acc. to A395) the standard range can be expanded up to -30 °C and 16 bar.</p> |
| <p>2 Tiefere Temperaturen durch Sondermaterial</p> | <p>Lower temperatures by special materials</p> |
| <p>3 Höheres Vakuum bei Pumpenstillstand durch Sonderspalttöpfe</p> | <p>Higher vacuum at pump standstill by special can unit</p> |

CE Konformitätserklärung nach EN ISO/IEC 17050
Declaration of Conformity according to EN ISO/IEC 17050

Produkt	Magnetkupplungs-Chemiekreiselpumpe freies Wellenende, Blockausführung oder als Aggregat ¹⁾		
Product	Magnetic Drive Chemical Centrifugal Pump Bare shaft, block version or as unit ¹⁾		
Baureihe Series	MNK, MNK-B, MNK-X, MNK-XB, MNK-S, MNK-SB, MPB, RMI, RMI-B		
Seriennummer Serial number	ab 01.04.2020 from 01.04.2020		
EU-Richtlinien EU-Directive	2006/42/EG Maschinenrichtlinie, Anhang II, Nr. 1 A 2014/34/EU Explosionsschutzrichtlinie ATEX 2006/42/EC Machinery Directive, Annex II, No. 1 A 2014/34/EU Equipment explosive atmosphere		
Modul	Interne Fertigungskontrolle Production Quality Assurance		
Angewandte harmonisierte Normen Applied harmonised Standards	DIN EN ISO 12100:2011, DIN EN 809:2012, DIN EN ISO 80079-36:2016 DIN EN ISO 15783:2010, DIN EN ISO 2858:2011		
Kennzeichnung Marking	2006/42/EG 2014/34/EU	2006/42/EC 2014/34/EU	CE  II 2/2 GD X Ex h IIC T4 ... T3 Gb Ex h IIC T135°C ... T200°C Db ¹⁾

Die technische Dokumentation nach Richtlinie 2014/34/EU ist bei der u.a. benannten Stelle hinterlegt.
 The technical documentation is filed by below mentioned notified body according to directive 2014/34/EU.
 Physikalische-Technische Bundesanstalt (PTB), D-38116 Braunschweig

Baureihe Series	Registrier-Nr. Registered #	Baureihe Series	Registrier-Nr. Registered #
MNK	02ATEXD032	MNK-SB	03ATEXD006
MNK-B	03ATEXD006	MPB	03ATEXD068
MNK-X	02ATEXD032	RMI	10ATEX D076
MNKXB	03ATEXD006	RMI-B	10ATEX D076
MNK-S	02ATEXD032		

Das Unternehmen Richter Chemie-Technik GmbH bescheinigt hiermit, dass die o.a. Baureihen die grundsätzlichen Anforderungen der aufgeführten Richtlinien und Normen erfüllt.
 Richter Chemie-Technik GmbH confirms that the basic requirements of the above specified directives and standards have been fulfilled.

Bevollmächtigt für die Zusammenstellung der technischen Unterlagen nach 2006/42/EG: G. Kleining
 Authorized person compiled the technical files according to 2006/42/EC:

1) Gilt nicht für das Aggregat nach 2014/34/EU
 1) Not valid for the unit according to 2014/34/EU

Kempen, 01.02.2023

 Barbara Wladarz
 Managing Director

 Gregor Kleining
 Director Global Engineering

CE Konformitätserklärung nach EN ISO//IEC 17050
Declaration of Conformity according to EN ISO//IEC 17050

Produkt <i>Product</i>	Magnetkupplungs-Chemiekreiselpumpe als Aggregat <i>Magnetic Drive Chemical Centrifugal Pump as unit</i>
Baureihe <i>Series</i>	MNK, MNK-B, MNK-X, MNK-XB, MNK-S, MNK-SB, MPB, RMI, RMI-B
Seriennummer <i>Serial number</i>	ab 01.04.2020 <i>from 01.04.2020</i>
EU-Richtlinien <i>EU-Directive</i>	2006/42/EG Maschinenrichtlinie, Anhang II, Nr. 1 A <i>2006/42/EC Machinery Directive, Annex II, No. 1 A</i>
Modul	Interne Fertigungskontrolle <i>Production Quality Assurance</i>
Angewandte harmonisierte Normen <i>Applied harmonised Standards</i>	DIN EN ISO 12100:2011, DIN EN 809:2012 DIN EN ISO 15783:2010, DIN EN ISO 2858:2011
Kennzeichnung <i>Marking</i>	2006/42/EG 2006/42/EC

CE

Das Unternehmen Richter Chemie-Technik GmbH bescheinigt hiermit, dass die o.a. Baureihen die grundsätzlichen Anforderungen der aufgeführten Richtlinien und Normen erfüllt.
Richter Chemie-Technik GmbH confirms that the basic requirements of the above specified directives and standards have been fulfilled.

Bevollmächtigt für die Zusammenstellung der technischen Unterlagen nach 2006/42/EG:
Authorized person compiled the technical files according to 2006/42/EC:

G. Kleining

Kempen, 01.02.2023

Barbara Wladarz
Managing Director
Quality

Gregor Kleining
Director Global Engineering



Konformitätserklärung in Übereinstimmung mit den Leitlinien der britischen Regierung
Declaration of Conformity in accordance with UK government guidance

Produkt Magnetkupplungs-Chemiekreiselpumpe
 freies Wellenende, Blockausführung **oder** als Aggregat¹⁾
*Product Magnetic Drive Chemical Centrifugal Pump
 Bare shaft, block version **or** as unit ¹⁾*

Baureihe MNK, MNK-B, MNK-X, MNK-XB, MNK-S, MNK-SB, MPB, RMI, RMI-B
Series

Seriennummer ab/from 01.01.2023
Serial number

UK Gesetzliche Vorschriften 2008 No. 1597 Maschinenverordnung 2008
 2016 No. 1107, UKEx 2016
*UK Statutory instruments 2008 No. 1597 The Supply of Machinery Regulations 2008
 2016 No. 1107, UKEx 2016*

Modul Interne Fertigungskontrolle
Production Quality Assurance

Angewandte technische Spezifikation DIN EN ISO 12100, DIN EN 809, DIN EN ISO 80079-36
 DIN EN ISO 15783, DIN EN ISO 2858
Applied Technical Specification

Kennzeichnung 2008 No. 1597, 2016 No. 1107
Marking 2008 No. 1597, 2016 No. 1107



Ex II 2/2 GD X Ex h IIC T4 ... T3 Gb
 Ex h IIC T135°C ... T200°C Db¹⁾

Die technische Dokumentation nach Richtlinie 2014/34/EU ist bei der u.a. benannten Stelle hinterlegt.
The technical documentation is filed by below mentioned notified body according to directive 2014/34/EU.
 Physikalische-Technische Bundesanstalt (PTB), D-38116 Braunschweig

Baureihe Series	Registrier-Nr. Registered #	Baureihe Series	Registrier-Nr. Registered #
MNK	02ATEXD032	MNK-SB	03ATEXD006
MNK-B	03ATEXD006	MPB	03ATEXD068
MNK-X	02ATEXD032	RMI	10ATEX D076
MNKXB	03ATEXD006	RMI-B	10ATEX D076
MNK-S	02ATEXD032		

Das Unternehmen Richter Chemie-Technik GmbH bescheinigt hiermit, dass die o.a. Baureihen die grundsätzlichen Anforderungen der aufgeführten Richtlinien und Normen erfüllt. Diese Erklärung wird unter der alleinigen Verantwortung des Herstellers abgegeben.

Richter Chemie-Technik GmbH confirms that the basic requirements of the above specified directives and standards have been fulfilled. This declaration is issued under the sole responsibility of the manufacturer.

Bevollmächtigt für die Zusammenstellung der technischen Unterlagen nach 2008 No. 1597: G. Kleining
 Authorized person compiled the technical files according to 2008 No. 1597:

1) Gilt nicht für das Aggregat nach 2016 No. 1107
 1) Not valid for the unit according to 2016 No. 1107

Kempen, 01.02.2023

 Barbara Wladarz
 Managing Director

 Gregor Kleining
 Director Global Engineering



Konformitätserklärung in Übereinstimmung mit den Leitlinien der britischen Regierung
Declaration of Conformity in accordance with UK government guidance

Produkt <i>Product</i>	Magnetkupplungs-Chemiekreiselpumpe als Aggregat <i>Magnetic Drive Chemical Centrifugal Pump as unit</i>
Baureihe <i>Series</i>	MNK, MNK-B, MNK-X, MNK-XB, MNK-S, MNK-SB, MPB, RMI, RMI-B
Seriennummer <i>Serial number</i>	ab 01.01.2023 <i>from 01.01.2023</i>
UK Gesetzliche Vorschriften <i>UK Statutory instruments</i>	2008 No. 1597 Maschinenverordnung 2008 2008 No. 1597 <i>The Supply of Machinery Regulations 2008</i>
Modul	Interne Fertigungskontrolle <i>Production Quality Assurance</i>
Angewandte technische Spezifikation <i>Applied Technical Specification</i>	DIN EN ISO 12100:2011, DIN EN 809:2012 DIN EN ISO 15783:2010, DIN EN ISO 2858:2011
Kennzeichnung <i>Marking</i>	2008 No. 1597 2008 No. 1597



Das Unternehmen Richter Chemie-Technik GmbH bescheinigt hiermit, dass die o.a. Baureihen die grundsätzlichen Anforderungen der aufgeführten Richtlinien und Normen erfüllt. Diese Erklärung wird unter der alleinigen Verantwortung des Herstellers abgegeben.

Richter Chemie-Technik GmbH confirms that the basic requirements of the above specified directives and standards have been fulfilled. This declaration is issued under the sole responsibility of the manufacturer.

Bevollmächtigt für die Zusammenstellung der technischen Unterlagen nach 2008 No. 1597: G. Kleining
Authorized person compiled the technical files according to 2008 No. 1597:

Kempen, 20.12.2022

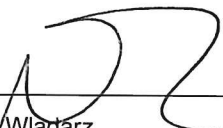
Barbara Wladarz
Managing Director

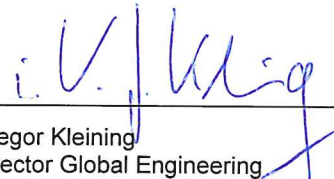
Gregor Kleining
Director Global Engineering

08.01.2015

Declaration of no objection

Dear Sirs,

The compliance with laws for the industrial safety obligates all commercial enterprises to protect their employees and/or humans and environment against harmful effects while handling dangerous materials.

The laws are such as: the Health and Safety at Work Act (ArbStättV), the Ordinance on Harzadous Substances (GefStoffV, BIOSTOFFV), the procedures for the prevention of accidents as well as regulations to environmental protection, e.g. the Waste Management Law (AbfG) and the Water Resources Act (WHG)

An inspection/repair of Richter products and parts will only take place, if the attached explanation is filled out correctly and completely by authorized and qualified technical personnel and is available.

In principle, radioactively loaded devices sent in, are not accepted.

Despite careful draining and cleaning of the devices, safety precautions should be necessary however, the essential information must be given.

The enclosed declaration of no objection is part of the inspection/repair order. Even if this certificate is available, we reserve the right to reject the acceptance of this order for other reasons.

Best regards

RICHTER CHEMIE-TECHNIK GMBH

Safety Information / Declaration of No Objection Concerning the Contamination of Richter-Pumps, -Valves and Components

1 SCOPE AND PURPOSE

Each entrepreneur (operator) carries the responsibility for the health and safety of his employees. This extends also to the personnel, who implements repairs with the operator or with the contractor.

Enclosed declaration is for the information of the contractor concerning the possible contamination of the pumps, valves and component sent in for repair. On the basis of this information for the contractor is it possible to meet the necessary preventive action during the execution of the repair.

Note: The same regulations apply to repairs **on-site**.

2 PREPARATION OF DISPATCH

Before the dispatch of the aggregates the operator must fill in the following declaration completely and attach it to the shipping documents. The shipping instructions indicated in the respective manual are to be considered, for example:

- Discharge of operational liquids
- remove filter inserts
- lock all openings hermetically
- proper packing
- Dispatch in suitable transport container
- Declaration of the contamination fixed **outside!!** on the packing

Declaration about the Contamination of Richter Pumps, -Valves and Components



The repair and/or maintenance of pumps, valves and components can only be implemented if a completely filled out declaration is available. If this is not the case, delay of the work will occur. If this declaration is not attached to the devices, which have to be repaired, the transmission can be rejected.

Every aggregate has to have it's own declaration.

This declaration may be filled out and signed only by authorized technical personnel of the operator.

Contractor/dep./institute :		Reason for transmitting * Please mark the applicable	
Street :		Repair: <input type="radio"/> subject to fee <input type="radio"/> Warranty	
Postcode, city :		Austausch: <input type="radio"/> subject to fee <input type="radio"/> Warranty	
Contact person :		<input type="radio"/> Exchange/ Replacement already initiated/received	
Phone :	Fax :	Return: <input type="radio"/> Leasing <input type="radio"/> Loan <input type="radio"/> for credit note	
End user :			

A. Details of Richter-product:	Failure description:
Classification: _____	_____
Article number: _____	_____
Serial number: _____	_____

B. Condition of the Richter-product:						
	no ¹⁾	yes	no		Contamination :	no ¹⁾ yes
Was it in operation ?	<input type="radio"/>	<input type="radio"/>	<input checked="" type="radio"/>	→	toxic	<input type="radio"/> <input type="radio"/>
Drained (product/operating supply item) ?	<input type="radio"/>	<input type="radio"/>	<input type="radio"/>		caustic	<input type="radio"/> <input type="radio"/>
All openings hermetically locked!	<input type="radio"/>	<input type="radio"/>	<input type="radio"/>		inflammable	<input type="radio"/> <input type="radio"/>
Cleaned ?	<input type="radio"/>	<input type="radio"/>	<input type="radio"/>		explosive ²⁾	<input type="radio"/> <input type="radio"/>
If yes, with which cleaning agent:					mikrobiological ²⁾	<input type="radio"/> <input type="radio"/>
and with which cleaning method:					radioactive ³⁾	<input type="radio"/> <input type="radio"/>
¹⁾ if "no", then forward to D. ← ²⁾ Aggregates, which are contaminated with microbiological or explosive substances, are only accepted with documented evidence of an approved cleaning. ³⁾ Aggregates, which are contaminated with radioactive substances, are not accepted in principle.					other pollutant	<input type="radio"/> <input type="radio"/>

C. Details of the discharged materials (must be filled out imperatively)

1. **With which materials did the aggregate come into contact ?** Trade name and/or chemical designation of operational funds and discharged materials, material properties, e.g. as per safety data sheet (e.g. toxic, inflammable, caustic)

X	Trade name:	Chemical designation:
a)		
b)		
c)		
d)		

2. **Are the materials specified above harmful to health ?** no yes

3. **Dangerous decomposition products during thermal load ?** no yes

If yes, which ones? ←

D. Mandatory declaration: We assure that the data in this explanation are truthful and complete and as a signatory I am able to form an opinion about this. We are aware that we are responsible towards the contractor for damages, which results from incomplete and incorrect data. We commit ourselves to exempt the contractor from claims for damages of thirds resulting from incomplete or incorrect data. We are aware that we are directly responsible towards thirds, irrespective of this declaration, which belongs in particularly to the employees of the contractor consigned with the handling repair of the product.

Name of the authorized person (in block letters): _____

_____ _____

Date Signature

Company stamp

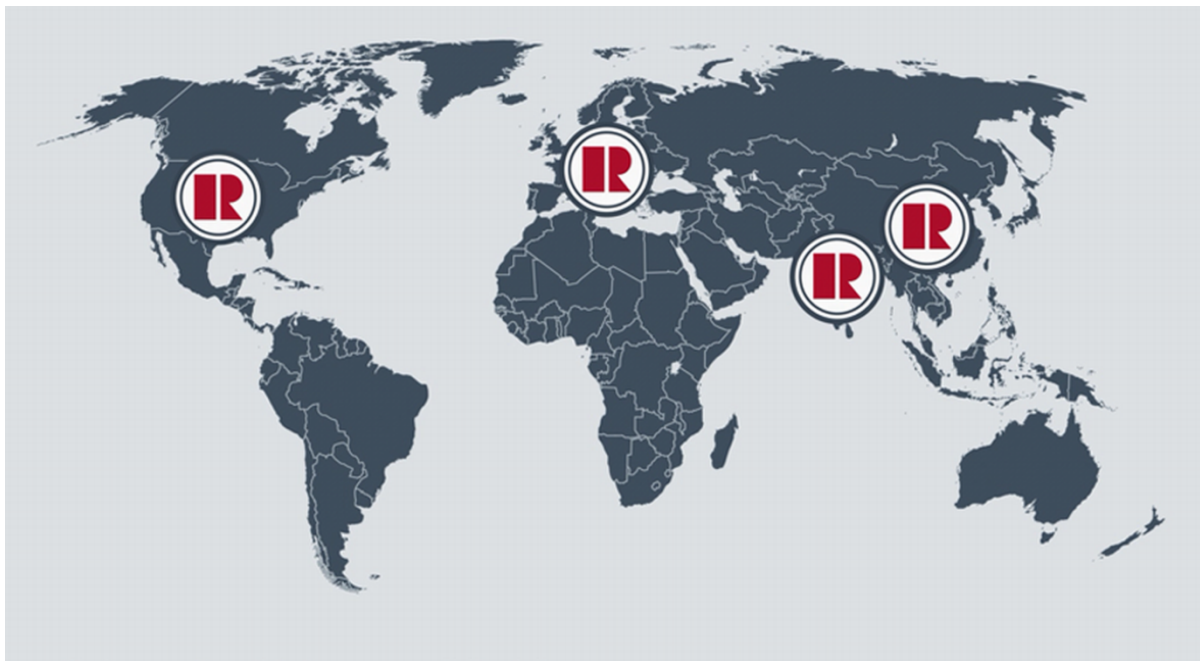

Richter Chemie-Technik GmbH
Otto-Schott-Str. 2
D-47906 Kempen / Germany
Tel: +49 (0) 2152 146-0
Email: Richter-Info@idexcorp.com
Internet: www.richter-ct.com

Richter Pumps and Valves
6041 Industrial Drive
Geismar, 70734, USA
Tel.: +1 225-673-9990
Email: RichterIncSales@idexcorp.com
Internet: www.richter-ct.com

Richter (EP), Nanjing, Shanghai Office
Room 3502 - 3504, Zhaofeng Plaza
No. 1027, Changning Road, Shanghai 200050 / China
Tel: +86 / 21 / 6150 - 9812
Email: RichterShanghai-Info@idexcorp.com
Internet: www.richter-ct.com

Richter Pumps & Valves Pvt. Ltd.
Survey No. 256, near Bombardier Circle, GIDC
Manjusar, Savli, Dist. Vadodara 391770, Gujarat / India
Tel: +91 2667-662-001
Email: info.fmt@idex
Internet: www.richter-ct.com

© Richter Chemie-Technik GmbH 2023
Subject to change without notice.
These installation and operating instructions must be kept!

Edition 07/2023
Revision 3.0
9230B001-en