

# Sanwa Stainless Steel Magnet Drive Pump Model MMP

## Instruction Manual

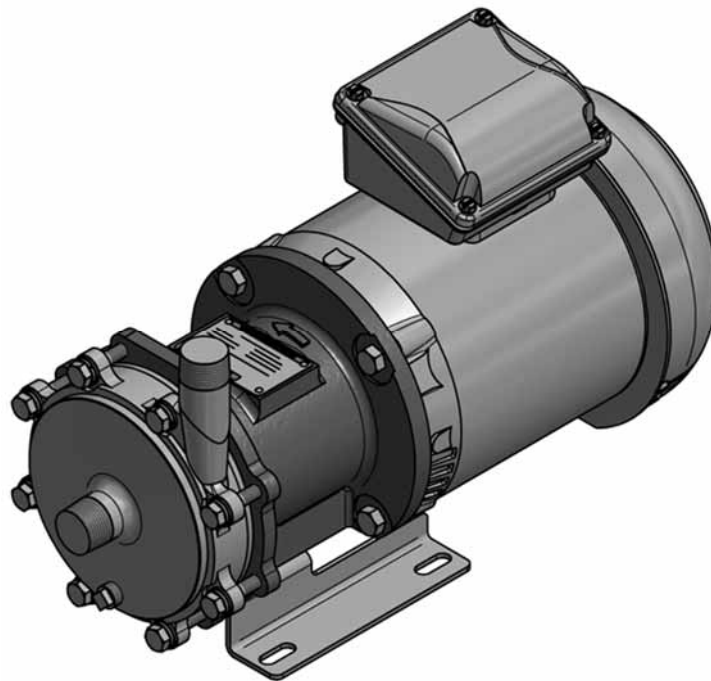

### Note

This instruction manual has been prepared for the personnel who will use the pump, so make sure it gets into the hands of the personnel in charge at the workplace where it will be used. Please contact Sanwa Hydrotech if equipment manufacturers or plant manufacturers would like copies to be provided.

**IWAKI AMERICA, INC.**

Five Boynton Avenue, Holliston, MA 01746 USA

Tel: 508-429-1440 / [info@iwakiamerica.com](mailto:info@iwakiamerica.com) / [iwakiamerica.com](http://iwakiamerica.com)

---

# Foreword

Thank you for purchasing the Sanwa Magnet Drive Pump. Every effort has been made in the manufacture of this product to ensure that it is safe for use. However, improper handling may lead to unforeseen accidents or prevent satisfactory pump performance from being achieved. Follow the instructions in this manual to ensure proper use of the pump. This manual should be kept at hand so it can be referred to when necessary.

**For information on motor handling, please refer to the instruction manual for the motor.**

## Important Safety Information

- To ensure safe and proper use of the pump, always observe the safety precautions noted in this manual during pump operation, maintenance, or inspection. Sanwa Hydrotech will not be responsible and not compensate for injuries or accidents that result from failure to observe these precautions.
- This manual uses the three marks shown below to indicate the level of danger in the event of improper pump handling.



**DANGER**

Indicates imminent danger that will lead to death or serious injury in the event of incorrect handling resulting from failure to observe the indicated instruction.



**WARNING**

Indicates a matter that may lead to death or serious injury in the event of incorrect handling resulting from failure to observe the indicated instruction.



**CAUTION**

Indicates a matter that may lead to injury or property damage in the event of incorrect handling resulting from failure to observe the indicated instruction.

Please note that serious consequences may result even in the case of matters in  **CAUTION** , depending on the situation. All three marks indicate important matters, so be sure to observe the instructions noted therein.



## DANGER

### General

- Do not use this product in an explosive atmosphere, as this will lead to injury, fire, or other adverse consequences. If the product must be used in an explosive atmosphere, use a pump that allows a pressure-resistant explosion-proof motor or the like to be installed.
- When pumping liquids with a low flash ignition temperature or a low ignition temperature, use an explosion-proof motor that is appropriate for that atmosphere.
- Do not use under hot line conditions. Always turn off the power before use. Failure to do so may result in electric shock.

### Operation

- Never touch or get near the rotating parts while the pump is operating. You may get caught in the moving parts and injured.
- In the event of a power outage, be sure to disconnect the pump from the power source. Failure to do so may result in injury when power is unexpectedly supplied again.

### Maintenance and inspection

- Consult the connection diagram inside the terminal box or the instructions in the motor instruction manual when connecting the power cable. Failure to do so may result in electric shock or fire.



## WARNING

### General

- Do not insert fingers or objects into the apertures on the pump and motor. Doing this may result in electric shock, injury, fire, or other adverse consequences.

### Installation and adjustment

- Never place flammable objects near the pump, as this may result in fire.

### Operation

- Rotating part warning: Do not insert your fingers or the like into the frame adapter aperture during operation, as you may be injured by coming in contact with rotating parts.



## WARNING

### Disassembly and assembly

- Hazardous liquid caution: When the liquid being handled is a hazardous chemical, drain the liquid and then clean the pump thoroughly before disassembly. Small quantities of liquid will remain on the threads, spigot joint sections, and interface sections inside the pump. Therefore, when handling chemicals that are hazardous to human health, be sure to wear protective gear (safety goggles, rubber gloves, etc.) and be very careful during disassembly.
- Pinch warning: During disassembly or assembly of the magnet coupling, parts may be strongly attracted by magnetic force. Make sure your fingers or hands do not get pinched between these parts.



## CAUTION

### General

- Transport, installation, piping, wiring, operation, maintenance, and inspection processes should be performed by persons with specialist knowledge. Performance by persons without such knowledge may result in electric shock, injury, fire, or other adverse consequences.
- Be sure to use a power supply with the voltage shown on the motor nameplate. Use of other voltages may result in electric shock, injury, damage, or other adverse consequences.
- Do not attempt to use damaged motors, as this may result in injury, fire, or other adverse consequences.
- Never attempt to modify the product yourself, as this may result in unforeseen accidents. Such modifications are outside the scope of the warranty and Sanwa Hydrotech will not be held responsible for the consequences.
- Make sure nameplates and warning labels are visible at all times. Do not place objects in front of nameplates and warning labels.
- Do not remove nameplates or warning labels.

### Shipment/transport

- Dangerous consequences may result if the pump should fall or topple during transport, so transport the pump carefully. If the pump has an eyebolt, be sure to use it. However, after the pump has been installed in the machinery, do not attempt to hoist the entire machine with the eyebolt.

Before attempting to hoist the pump, check the weight of the pump in the catalog or other reference, and do not attempt to hoist the pump if it is heavier than the load rating of the hoisting gear. Attempting to do so may cause the bolt to break, resulting in injury or damage of the pump due to its falling or toppling.



## CAUTION

- The pump bearings are made of a very hard material, but they are susceptible to vibrations and impacts, so handle them carefully during shipment and transport. Similarly, place the pump gently when installing it in the machinery.

### Unpacking

- Check to make sure the box is right side up before unpacking the pump. Failure to do so may result in injury.
- Check the delivery specifications and the nameplate to make sure the product that has been delivered is the one that was ordered. Installing the wrong pump may result in injury or damage.



### Piping/wiring

- Consult the connection diagram inside the terminal box or the instruction manual when connecting the power cable. Failure to do so may result in electric shock or fire.
- Do not bend or pull the power cable or motor lead wires excessively, and make sure they are not pinched, as this may result in electric shock.

### Installation/adjustment

- Be sure to attach a ground wire securely to the ground terminal. Failure to do so may result in electric shock.

### Operation

- Do not operate the pump without the cover of the terminal box in place. Replace the terminal box cover in its proper position after completing the electrical wiring work. Failure to do so may result in electric shock.
- To prevent burns or frostbite, keep your hands away from the casing and frame adapter when using the pump with extremely hot or extremely cold liquids.
- No-load operation   
Never operate the pump in no-load status, as high temperatures that may damage the bearings will be generated inside the pump. Always supply liquid when operating the pump. (Also, be sure to supply liquid when confirming the direction of rotation.)  
Operating the pump without a load will produce heat in the can part, and this may demagnetize magnets.
- Shut-off operation   
Do not perform the shut-off operation for more than one minute. Shut-off for longer than this will cause the temperature of the liquid inside the pump to rise dramatically, possibly resulting in accident.

---

# Contents

Foreword

Important Safety Information

- Safety Checks and Precautions ..... 6
- Shipment, Transport and Unpacking ..... 7
  - 1. Shipment and transport ..... 7
  - 2. Unpacking ..... 7
- Before Use ..... 7
- Pump Models ..... 9
- Pump Model Codes ..... 9
- Pump Specifications ..... 10
- Pump Installation ..... 12
  - 1. Installation ..... 12
  - 2. Piping ..... 12
  - 3. Electrical wiring ..... 13
- Operation ..... 14
  - 1. Preliminary inspection ..... 14
  - 2. Operation ..... 14
  - 3. Shutdown ..... 17
- Maintenance and Inspection ..... 18
  - 1. Regular inspection ..... 18
  - 2. Pump configuration and part names ..... 19
  - 3. Disassembly and assembly order ..... 20
  - 4. Part dimensions ..... 23
  - 5. Optimal Tightening Torque for Bolts and Nuts ..... 24
- Troubleshooting ..... 25
- Repair and Warranty ..... 27

---

# Safety Checks and Precautions

---

- Before use (installation, operation, maintenance, inspection, etc.), be sure to carefully read this Instruction Manual and all associated documents, and follow the instructions to ensure proper use. Make sure you have a thorough knowledge of the product and a thorough understanding of all safety information and precautions before attempting to use the product.

## Things to check to avoid equipment failure and accident as well as to ensure safe operation

- Pre-operational check

Check the power supply, wiring/connections, piping status, priming and venting status, and direction of rotation.

- Check prior to beginning a trial operation and actual operation

Check the current, voltage, suction pressure, discharge pressure, and discharge volume. Also, check to make sure there is no abnormal vibration, noise, and leakage from any part of the unit.



### **DANGER**

- Do not forget to take special disaster prevention measures during the trial operation check procedure when handling hazardous, explosive, or flammable liquids.

## Notes and precautions when the pump is used for special liquids

- Pumps are used in various industries. Stainless steel magnet drive pumps, in particular, are often used for explosive or flammable liquids and liquids that are hazardous to human health. Errors in the handling of pumps may result in serious harm to life or health and major property damage. Be sure to read this Instruction Manual carefully to ensure proper operation for preventing such harm and damage.



### **DANGER**

- Be sure to provide the necessary safety equipment and exercise proper caution when using the pump for liquids such as the following:
  - Explosive liquids
  - Liquids that may cause chemical reactions
  - Flammable liquids
  - Liquids that are directly harmful to human health

- Accident prevention equipment should be provided for pumps installed in the main sections of production lines and special pumps in order to guard against natural disasters, unexpected accidents, failures, etc. and ensure that these events do not cause serious damage to production operations. If such equipment cannot be installed, a spare pump (if possible, one equipped with a motor or other drive unit) should be prepared so it can be used if necessary.

---

# Shipment, Transport and Unpacking

---

## 1. Shipment and transport



### CAUTION

- Dangerous consequences may result if the pump should fall or topple during transport, so transport the pump carefully. If the pump has an eyebolt, be sure to use it. However, after the pump has been installed in the machinery, do not attempt to hoist the entire machine with the eyebolt.

Before attempting to hoist the pump, check the weight of the pump in the catalog or other reference, and do not attempt to hoist the pump if it is heavier than the load rating of the hoisting gear. Attempting to do so may cause the bolt to break, resulting in injury or damage due to falling or toppling.

- The pump bearings are made of a very hard material, but they are susceptible to vibrations and impacts, so handle them carefully during shipment and transport. Similarly, place the pump gently when installing it in the machinery.

## 2. Unpacking



### CAUTION

- Check to make sure the box is right side up before unpacking the pump. Failure to do so may result in injury.
- Check the delivery specifications and the nameplate to make sure the product that has been delivered is the one that was ordered. Injury, damage, etc. may result if the wrong pump is installed.

---

## Before Use

---

As soon as the pump has been delivered, check the following points.

- To make sure that all accessories have been included, check the following:



### CAUTION

- Check the nameplate to make sure the product that has been delivered is the one that was ordered.
- Check to make sure the product has not been damaged during shipment and that the bolts and nuts have not been loosened.

If the above checks reveal that accessories are missing or if there are any other problems, please contact your dealer or the Sanwa Hydrotech.



---

## Nameplate of pump

TYPE \_\_\_\_\_

HEAD \_\_\_\_\_ ft CAP. \_\_\_\_\_ USGPM

RPM \_\_\_\_\_ DATE \_\_\_\_\_

IMP. DIA. \_\_\_\_\_ inch PUMP MASS \_\_\_\_\_ lb

SERIAL No. \_\_\_\_\_

2-11-33 MINAMIKANEDEN, SUITA, OSAKA, JAPAN

**SANWA HYDROTECH CORP.**

TYPE: Pump model and pump code

DATE: Date of manufacture

IMP. DIA.: Impeller diameter

PUMP MASS: Weight of pump not including motor

# Pump Models

M M **P**

**11**

1

2

Pump model

Pump size

## 1. Operating temperature range

P: Standard model

|   | Minimum temperature<br>°F ( ) | Maximum temperature<br>°F ( ) | Magnet material |
|---|-------------------------------|-------------------------------|-----------------|
| P | -22 (-30)                     | +302 (+150)                   | Nd              |

Note: Please contact Sanwa Hydrotech if significant increases and decreases in temperature occur repeatedly.

## 2. Pump size

| Pump size | Suction         | Discharge       | Motor frame        |
|-----------|-----------------|-----------------|--------------------|
|           |                 |                 | (NEMA)             |
| 11        | 1/2"<br>(15mm)  | 1/2"<br>(15mm)  | 56C<br>143TC,145TC |
| 21        | 3/4"<br>(20 mm) | 3/4"<br>(20 mm) | 56C<br>143TC,145TC |
| 22        | 1"<br>(25 mm)   | 3/4"<br>(20 mm) | 56C<br>143TC,145TC |

## Pump Model Codes (pump codes)

MMP22-1 N 07 N N

Pump model & size

Model : 『MMP』

Size : 『11』 『21』 『22』

Impeller nominal diameter (UNIT : mm)

| Pump Size | Code | Impeller Diameter mm (inch) |
|-----------|------|-----------------------------|
| MMP11     | 『1』  | 93 (3.66)                   |
| MMP21     | 『1』  | 122 (4.80)                  |
| MMP22     | 『1』  | 84 (3.31)                   |

### Type of Motor

☐N<sub>1</sub> : C-FACE NEMA motor

### Motor output & Magnet Coupling Type

| Code             | Output (HP) | Magnet Coupling Type | Motor Frame | Pump Type & Size |
|------------------|-------------|----------------------|-------------|------------------|
| ☐03 <sub>1</sub> | 1/3         | R25x6N               | 56C         | MMP11,           |
| ☐05 <sub>1</sub> | 1/2         |                      |             | MMP21,           |
| ☐07 <sub>1</sub> | 3/4         |                      |             | MMP22            |

### Pipe Connection & Pump Material

☐N<sub>1</sub> : NPT & ACI-CF-8M (AISI316)

### Temp Code

☐N<sub>1</sub> : -4 – +248 °F (-20 – +120 )

☐H<sub>1</sub> : +249 – +302 °F (+121 – +150 )

( ☐H<sub>1</sub> is to apply only to MMP21)

☐L<sub>1</sub> : -22 – -5 °F (-30 – -21 )

## Pump Specifications

### 1. Design pressure

|     |    | DESIGN PRESSURE (psig) |
|-----|----|------------------------|
| MMP | 11 | 87                     |
|     | 21 | 145                    |
|     | 22 | 87                     |

### 2. Casing pipe connections

Suction and discharge : NPT Threads (National pipe thread taper ANSI B 1.20.1)

Drain : NPT Threads (National pipe thread taper ANSI B 1.20.1)

### 3. Viscosity

300mPa · s

### 4. Magnet coupling

| PUMP | SIZE         | MAGNET COUPLING |
|------|--------------|-----------------|
| MMP  | 11 , 21 , 22 | R25x6N          |

## 5. Motor

Rated output: NEMA motor : 1/3HP , 1/2HP , 3/4HP

Frame: NEMA motor : 56C

## 6. Part specifications

|                        |       | -22 - -5°F<br>(-30 - -21 )   | -4 - +248°F<br>(-20 - +120 )   | +249 - +302°F<br>(+121 - +150 ) |
|------------------------|-------|--|--|---------------------------------|
| Gasket<br>or<br>O ring | MMP11 | PTFE mixed with<br>glass fiber<br>or<br>VMQ  | PTFE   |                                 |
|                        | MMP21 |  | PTFE   | PTFE mixed with<br>glass fiber  |
|                        | MMP22 |  | PTFE   |                                 |
| Frame<br>adapter       | MMP11 | <ul style="list-style-type: none"> <li>• Low temp. type</li> <li>Frame adapter</li> <li>• Liquid Gasket</li> </ul> | <ul style="list-style-type: none"> <li>• Standard Frame adapter</li> </ul> |                                 |
|                        | MMP21 |  |  |                                 |
|                        | MMP22 |  |  |                                 |

## 7. Ambient temperature

Ambient temperature : -4 - +104 °F (-20 - +40 )

## 8. Speed of rotation

Maximum speed of rotation : 3600 rpm

## 9. Flow rate for operation

Minimum flow rate for operation : (see individual data sheets)

Maximum flow rate for operation : 1.1 times maximum efficiency flow rate

---

# Pump Installation

---

## 1. Installation

1. Hoist the pump into position
2. Install the pump
  - Determine the location for pump installation based on a study of the suction head.
  - Install the pump in a location where maintenance and inspections can be performed easily.
  - Make sure the foundation has an area and volume large enough to accommodate the weight of the pump and motor, and that it can adequately absorb vibrations. Fasten the pump securely to the foundation using anchor bolts.
  - Be sure to clean the suction water tank and suction pipes thoroughly before filling the tank with liquid. Dirt and foreign matter in the tank and pipes may cause pump trouble.



### CAUTION

- Before hoisting the pump, confirm the weight of the pump (including the motor) and use ropes and hoisting gear that will support its weight. Hoist the pump carefully to make sure it does not fall.

## 2. Piping

- Place the horizontal sections of the suction pipe so they rise gradually to the pump suction port (gradient of 1/50 or more).
- Attach a foot valve or strainer to the ends of the suction pipe so foreign matter or the like will not be sucked in.
- Attaching a gate valve to the suction pipe will facilitate disassembly and inspection when the suction side is in flood suction and positive pressure status. Be sure to set the valve to fully open during pump operation.

### CAUTION

- Make sure that the pipes are properly supported. If the weight of the suction and discharge pipes is applied to the pump, this may result in pump misalignment and pump malfunction.
- The suction pipe should be as short as possible, with as few bends as possible.
- Never use a suction pipe whose diameter is smaller than the pump bore.
- Make sure there are no protruding sections in the horizontal part of the suction pipe, as air may collect in these locations during operation.
- Make sure that chips of threaded pipes and foreign matter do not enter inside when piping.

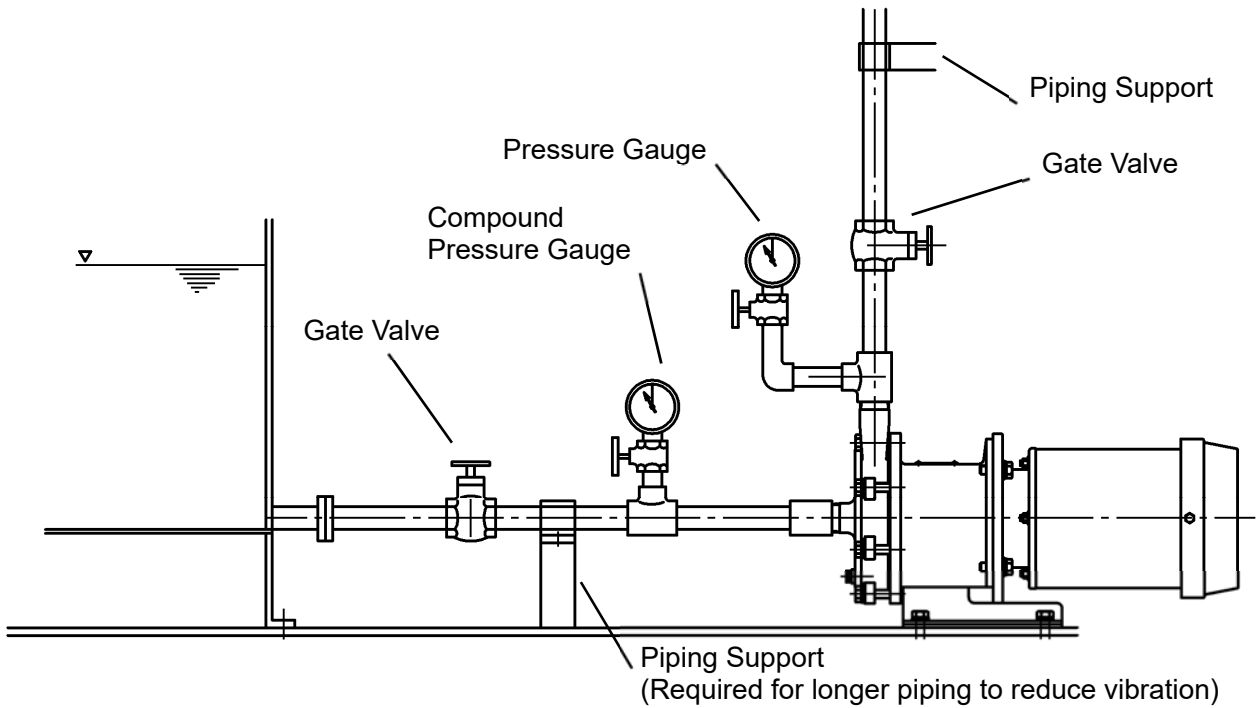

### 3. Electrical wiring



#### **DANGER**

- Install the power supply equipment for the motor and conduct the wiring and groundwork, etc. properly in accordance with the technical standards for electrical installation and indoor wiring regulations. It is against the law for unqualified persons to conduct imperfect wiring or groundwork. Furthermore, this would be extremely dangerous. Therefore, under no circumstances should this be done. In addition, installation of earth leakage breakers and overload protection equipment is required by law in order to prevent electrical shock and fire.

---

# Operation

---

## 1. Preliminary inspection (be sure to turn off the power beforehand)

1. Retighten the flange bolts and base bolts.
2. Clean the pipes and the inside of the tank thoroughly. Then fill the tank with water.
3. Using a thin rod or the like, turn the blades of the motor fan to make sure they turn easily.
4. Purge all of the air from the pump.
  - In the case of positive pressure  
Open the suction pipe and discharge pipe valves for the pump all the way. Purge all of the air from the inside of the pump casing.
  - If the air inside the pump casing cannot be purged even when the discharge pipe valve is opened all the way, attach an air bleed pipe to the discharge pipe and then purge the air from the inside of the pump casing.

## 2. Operation

1. When priming is finished, close the discharge pipe valve and press the switch once or twice to turn the unit on and off and check the direction of rotation (it should be clockwise as viewed from the motor side) and the operational status to make sure there are no problems.
  - If the motor is rotating in reverse, change the three-phase connection so the motor turns in the right direction. (Check the direction of rotation using the arrow displayed on the frame adapter and the motor fan's direction of rotation.)
  - To start the pump, close the valve of the discharge pipe all the way. Make sure that the discharge valve is closed before starting the pump.
  - If the pump liquid is at a low temperature (0°C or lower), turn the motor by hand just before starting operation to make sure it turns easily. If it does not turn smoothly, remove the motor and check to see if moisture has condensed or frozen in the rear casing and the outer magnets.
2. When the specified speed of rotation has been reached, open the discharge valve within one minute.
3. After starting the pump, check to make sure there is no abnormal noise and vibration as well as increase in discharge pressure increases. After the pump has begun operating at the specified r.p.m. and the value on the discharge pressure gauge has risen to the shut-off pressure, gradually open the discharge valve until the specified discharge pressure has been achieved.

- CAUTION**
- Do not operate the pump for long periods of time with the discharge valve closed. (Normally one minute or less is the limit.)
  - A motor overload may occur if the discharge valve is opened too far. Monitor the ammeter during operation to make sure overcurrent does not occur.

---

## Operation and Handling Considerations

### (Precautions for Operation)

- Never operate the pump in cavitation or no-load status, as this may damage the bearings. Shut off the pump.
- If the magnet coupling slips, shut off the pump within one minute. Continuing to operate the pump while the magnet coupling has slipped will demagnetize the magnet coupling and may cause the pump to fail.
- When pumping a low-temp fluid with temperature  $\leq +32^{\circ}\text{F}$  (0 °C), there causes a possibility of frozen/condensate adhesion of outside air moisture to the pump. In such application, leave the valve at frame adapter opened to be able to release collected water inside the frame adapter. If the pump is not in use, discharge the low-temp fluid from the pump. Or else, by implementing a bypass-piping. etc., keep the pump operated.

Corrective action: Installation of a no-load operation monitoring unit is recommended.





#### **WARNING**

- Do not insert your fingers or the like into the frame adapter aperture during operation. You may be injured by coming in contact with rotating parts.



#### **CAUTION**

- Precautions when using pump for extremely hot or extremely cold liquids  
To prevent burns or frostbite, keep your hands away from the casing and frame adapter when using the pump with extremely hot or extremely cold liquids.
- Prohibition of no-load operation   
The bearings are self-lubricating using the pumped liquid. Therefore, never operate the pump in no-load status. In the event that the pump has been inadvertently operated in no-load status for several seconds, wait at least one hour for the pump to cool before operating the pump and supplying liquid. (This is to make sure that ceramic and other materials that are susceptible to sudden cooling do not crack.)
- Prohibition of shut-off operation   
Performing the shut-off operation for long periods of time will cause the temperature inside the pump to rise, possibly resulting in accidents.



---

## Effect of temperature

- The performance of the pump itself will not be affected by changes in temperature. However, the specific gravity, viscosity, vapor pressure, corrosiveness, etc. of the liquids that are handled will change along with changes in temperature. Therefore, it is necessary to be aware of changes in the properties of the liquids that are handled.

| Model | Operating Temperature Range      |
|-------|----------------------------------|
| MMP   | - 22 - + 302 °F<br>(-30 - +150 ) |

Significant heat cycling (increases and decreases in temperature) may cause leakage from the container seals.

## Changes in performance due to specific gravity

- The discharge pressure and power consumption will change when pumping the high specific gravity liquid. Use a proper power unit (motor, inner magnet coupling, and outer magnet coupling) for the high specific gravity liquid.

## Changes in performance due to viscosity

- When pumping highly viscous liquids, the discharge quantity and pump head will decrease as compared to fresh water, while conversely the power requirements will increase. Use a proper power unit for the power requirements.

## Handling of slurry

- The pump is designed to handle small quantities of slurry and sludge. However, before pumping slurry, always determine the slurry quantity, particle size, etc. and consult the manufacturer.

## Changes in properties due to specific heat

- The performance of the pump itself will not be affected by changes in temperature. However, if the specific heat of the liquid being handled is low, the temperature inside the pump will rise significantly. The specific gravity, viscosity, steam pressure, corrosiveness, etc. of the liquids that are handled will change along with changes in temperature. Be very careful with changes in the properties of the liquids being handled, particularly if the specific heat is low.
- Be very careful with the temperature increase, as the temperature may rise significantly in closed-loop circulating operation.

---

## Noise level

- The table below shows the noise level of each pump model.
- The noise level will vary depending on the properties of the motor itself, the pump flow rate, the piping design, the acoustic properties of the building, etc. In addition, the noise level may increase when the inverter control is used to operate the motor.

|     |    | 2P×60Hz<br>dB(A) | 2P×50Hz<br>dB(A) |
|-----|----|------------------|------------------|
| MMP | 11 | 66               | 66               |
|     | 21 | 68               | 68               |
|     | 22 | 68               | 68               |

(at a distance of 1 m from the motor)

## 3. Shutdown

1. Close the discharge valve.
2. Turn off the motor. Check to make sure that the motor slows down and stops smoothly. (If it does not stop turning smoothly, conduct an inspection to see if there is a problem inside the pump.)
3. In the event that a power outage occurs during pump operation, immediately disconnect the pump from the power source and close the discharge gate valve.
4. When pumping a low-temp fluid and stop its operation, make sure to discharge the low-temp fluid from the pump. Otherwise, there causes a possibility of frozen/condensate adhesion of outside air moisture to the pump, and it may lead to a malfunction of motor and pump.

---

# Maintenance and inspection

---

## 1. Regular inspection

| Inspection Item  | Criteria and Precautions   |
|--|--|
| Does the pump operate smoothly without vibrating?            | The allowable value for vibration is a maximum of 28/33 $\mu$ m (both amplitude) when a 2P motor is used and a maximum of 47/54 $\mu$ m (both amplitude) when a 4P motor is used (JIS-B8301 60/50HZ). If noise from the bearing section or other abnormal noise is produced, immediately turn off the pump and inspect each part of the pump. If you are unable to locate the cause, please contact Sanwa Hydrotech immediately. |
| Water level in the suction pipe and pressure at suction port | The value on the pressure gauge is proportional to the specific gravity of the liquid. Open the gauge cock on the pressure gauge and compound pressure gauge only when conducting measurements. Close the cock when measurements have been completed.  |
| Pump operating load  | Check the discharge pressure during operation against the value displayed on the pump nameplate. Also, check to make sure that the current value is no greater than the value displayed on the motor nameplate.  |

- At least once each year, the pump should be disassembled and inspected, and parts should be replaced at this time if necessary. Be sure to keep records of these inspections.
- Always drain the liquid when the pump will not be used for an extended period of time (by removing the plug and allowing the liquid to drain out). In cold regions, the liquid may freeze and damage the pump.
- Frequently starting up the pump will reduce the service life of both the pump and the motor. The pump should not be started up more than six times in a single hour.

## 2. Pump configuration and part names

Part names (see table below) and assembly diagrams (see next page) have been provided to give you a general understanding of the pump as an aid to proper pump handling. Use these as a reference when consulting the Instruction Manual.

### Part names

| No. | Part                              | Material             | Qty.           | Remark      |
|-----|-----------------------------------|----------------------|----------------|-------------|
| 101 | Motor shaft key                   | ASTM A575 1045       | 1              |             |
| 100 | Motor                             |                      | 1              |             |
| 69  | Name plate                        | AISI 304             | 1              |             |
| 64  | Hexagon head bolt (base)          | AISI 304             | 4 <sup>S</sup> |             |
| 63  | Hexagon head bolt and nut (motor) | AISI 304             | 4              |             |
| 62  | Hexagon head bolt (casing)        | AISI 304             | 6 <sup>S</sup> |             |
| 61  | Set screw                         | ASTM A294135         | 1              |             |
| 50  | Base                              | AISI 304             | 1              |             |
| 45  | Bushing                           | SiC-D                | 2              |             |
| 33  | O ring                            |                      | 1              | size 11, 22 |
|     | Sheet gasket                      |                      | 1              | size 21     |
| 29  | Thrust ring                       | SiC                  | 1              |             |
| 20B | Magnet coupling (outer)           | ASTM A536 Gr, 60     | 1              |             |
| 20A | Magnet coupling (inner)           | AISI 316             | 1              |             |
| 15  | Frame adapter                     | ASTM A48M CLASS, 30B | 1              |             |
| 8   | Shaft                             | SiC                  | 1              |             |
| 4   | Rear casing                       | AISI 316             | 1              |             |
| 2   | Casing                            | ACI-CF-8M            | 1              |             |
| 1A  | Pin                               | AISI 316             | 2              |             |
| 1   | Impeller                          | ACI-CF-8M            | 1              |             |

NOTE: Part#1Impeller and #20A Magnet coupling(P) are built as an integral structure.

### Assembly diagram

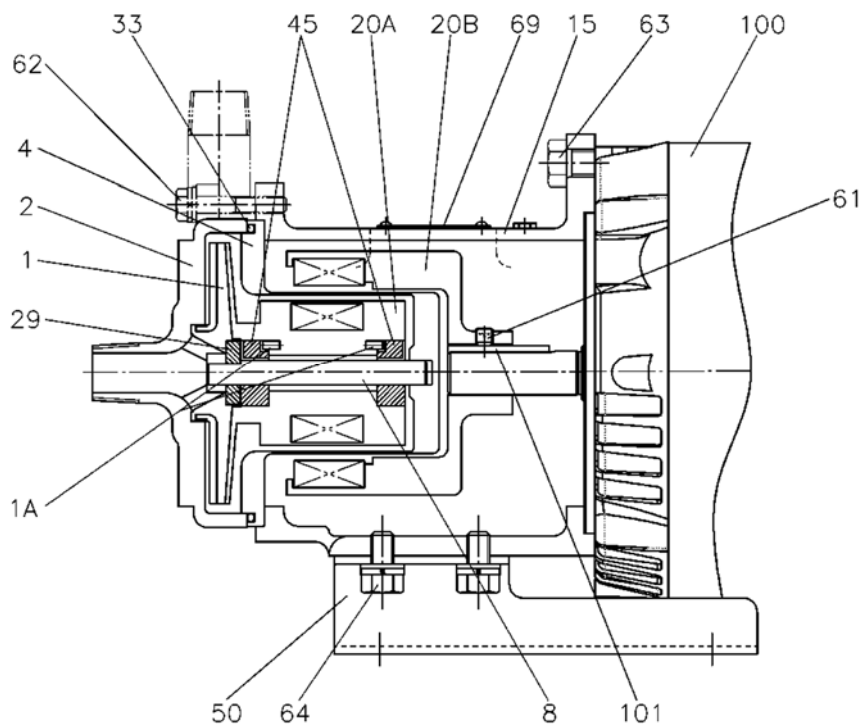

### 3. Disassembly and assembly order



#### CAUTION

- The magnet coupling uses powerful magnets that will attract iron and other magnetic materials. Use a workbench that is made of wood, plastic, or other non-magnetic material.
- The use of non-magnetic stainless steel tools for disassembly is recommended. If iron or other tools are used for disassembly, keep these tools away from the magnets.

| Disassembly Order | Part No. | Part                                  | Important Suggestions  | Assembly Order |
|-------------------|----------|---------------------------------------|--|----------------|
| 1                 |          | Bolts to fix pump(4 pcs)              |  | 23             |
| 2                 |          | Drain plug (No plug for MMP11)        | Completely drain from the casing   | 22             |
| 3                 | 62       | Casing bolts (6 pcs)                  | Tighten each bolt equally when assembling  | 21             |
| 4                 | 2        | Casing                                | Pull out carefully and quietly   | 20             |
| 5                 | 1,8,20A  | Impeller & inner magnet coupling assy | Rough handling is prohibited for SiC shaft   | 19             |
| 6                 | 29       | Thrust ring                           |  | 18             |
| 7                 | 8        | Shaft                                 |  | 17             |
| 8                 | 45       | Bushing                               | (Front side)   | 16             |
| 9                 | 1A       | Pin                                   | (Front side) No need to disassemble this pin   | 15             |
| 10                | 45       | Bushing                               | (Rear side)  | 14             |
| 11                | 1A       | Pin                                   | (Rear side) No need to disassemble this pin  | 13             |
| 12                | 1        | Impeller                              | Check the inside of impeller. When impeller is clogging, cooling flow for bearing will be lower. | 12             |
| 13                | 33       | O ring                                |  | 11             |
| 14                | 4        | Rear casing                           |  | 10             |
| 15                | 63       | Bolts to fix motor (4 pcs)            |  | 9              |
| 16                | 100,20B  | Motor & outer magnet coupling         |  | 8              |
| 17                | 61       | Set screw                             | Use hexagonal wrench for M6 screw  | 7              |
| 18                | 20B      | Outer magnet coupling                 |  | 6              |
| 19                | 101      | Key for motor shaft                   |  | 5              |
| 20                | 100      | Motor                                 |  | 4              |
| 21                | 64       | Hexagon bolts (4 pcs)                 | No need to disassemble these bolts   | 3              |
| 22                | 50       | Base                                  |  | 2              |
| 23                | 15       | Frame adapter                         |  | 1              |

Note: Be careful with the following when attaching the magnet coupling (M) (Part No. 20B) to the motor (Part No. 100).

1. Precautions when attaching the magnet coupling to the motor shaft

1-1 If the magnet coupling is difficult to attach to the motor shaft, lubricate with oil or the like to make it slide more easily and then press it in. Do not tap it directly; use a cylindrical jig (a non-magnetic material such as a piece of wood) to tap the base of the magnet coupling and press it in. Tapping the magnet coupling directly may damage the magnets.

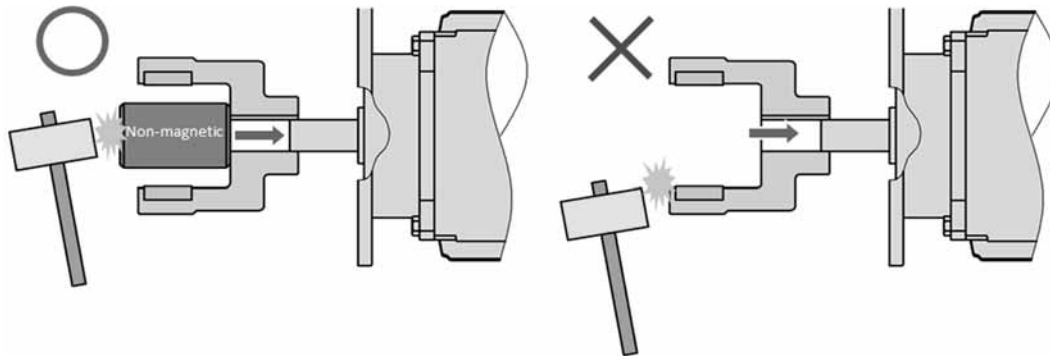

1-2 Press the magnet coupling straight onto the motor shaft. If it is at an angle, the shaft may be damaged.

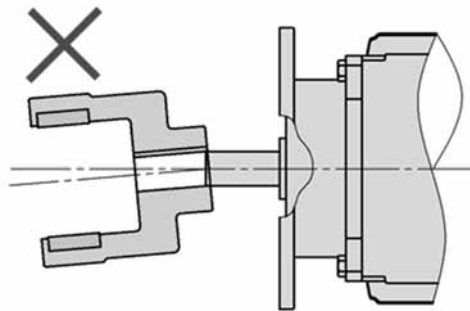

1-3 Press the magnet coupling in until the end of the motor shaft and the coupling (M) are at the same position.

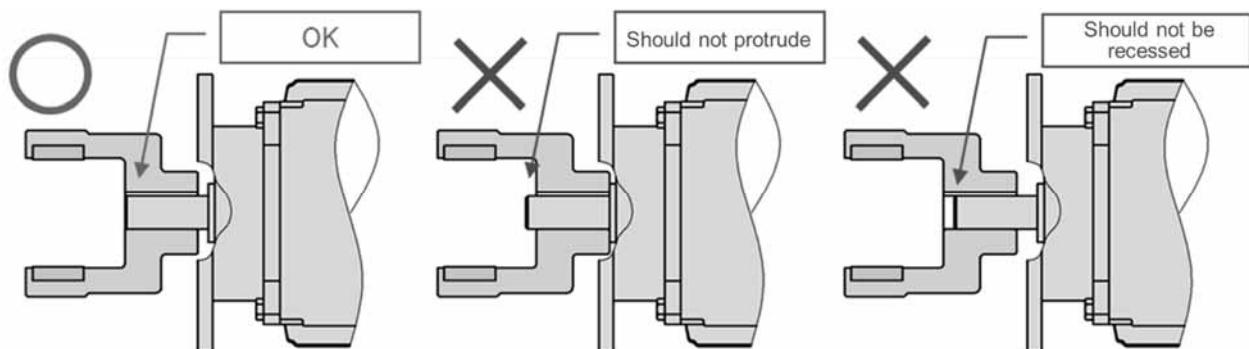

Numbers indicate the part No..

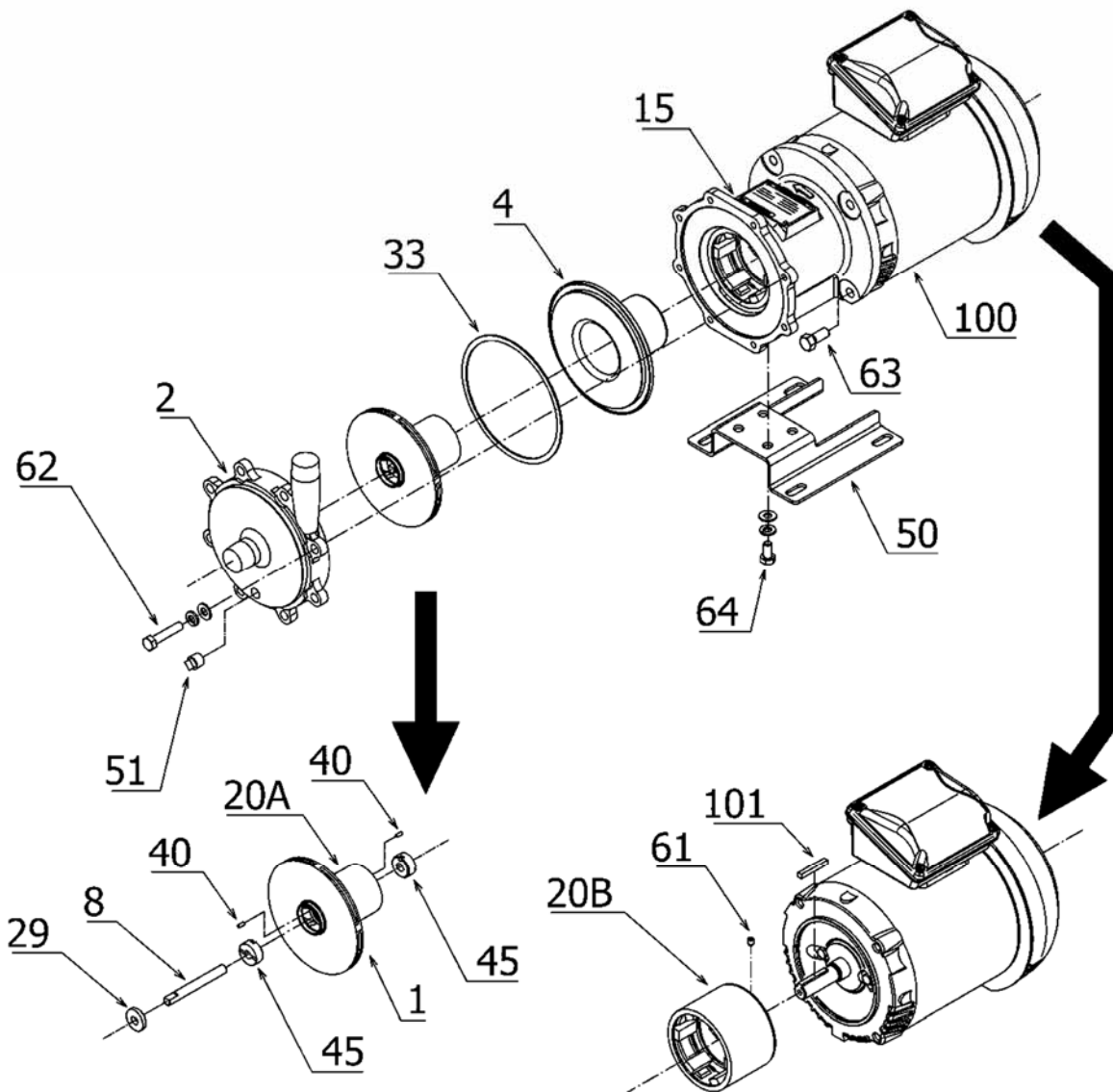

### CAUTION

- When the liquid being handled is a hazardous chemical, drain the liquid and then clean the pump thoroughly before disassembly. Small quantities of liquid will remain on the threads, spigot joint sections, and interface sections inside the pump. Therefore, when handling chemicals that are hazardous to human health, be sure to wear protective gear (safety goggles, rubber gloves, etc.) and be very careful during disassembly.
- Exercise caution as the parts will be attracted by the magnets. Be sure to maintain your grip on them during the removal process.
- The rear casing can section is very thin, so handle it carefully.

## 4. Part dimensions

If the clearance between rotating and stationary components is out of limitation, it may happen that these component contact and resulting frictional heat entail excessive temperatures.

Check the following dimensions, when disassembled. If measured dimension exceeds the allowance, replace damaged parts by new original spare parts.

· Dimension of Journal bearing inch (mm)

| BUSHING                       |   | SHAFT  | THRUST RING                  |
|-------------------------------|---|--|------------------------------|
| L                             | D   | d  | T                            |
| 0.378 – 0.398<br>(9.6 - 10.1) | $\varphi 0.406 - \varphi 0.390$<br>( $\varphi 10.3 - \varphi 9.9$ ) | $\varphi 0.355 - \varphi 0.346$<br>( $\varphi 9.01 - \varphi 8.79$ ) | 0.181 – 0.201<br>(4.6 - 5.1) |

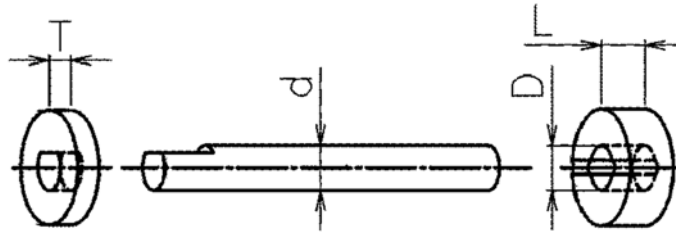

· Gap/Clearance of Journal bearing inch (mm)

|           | tf | tr          | Pf           | Pr           |
|-----------|----|-------------|--------------|--------------|
| Gap       | 0  | 0.020 (0.5) | 0.001 (0.03) | 0.001 (0.03) |
| allowance | 0  | 0.039 (1.0) | 0.008 (0.2)  | 0.008 (0.2)  |

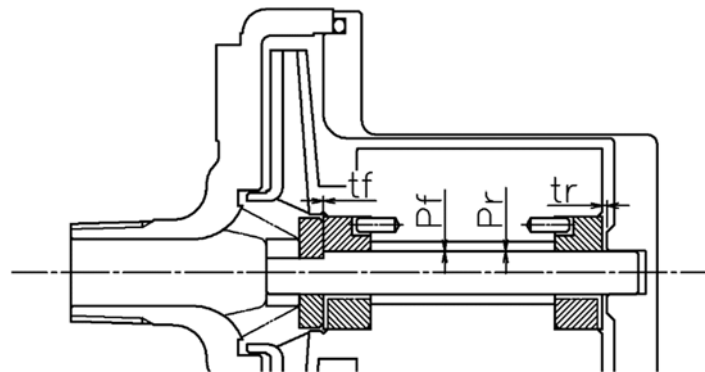

· Clearance between Impeller and casing

| PUMP TYPE | Z inch (mm)                |
|-----------|----------------------------|
| 11,21     | 0.018 – 0.024 (0.45 – 0.6) |
| 22        | 0.022 – 0.028 (0.55 – 0.7) |

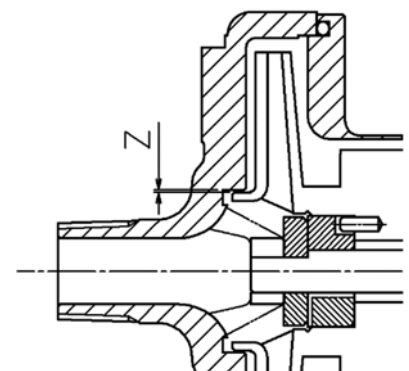



## 5. Optimal Tightening Torque for Bolts and Nuts

| Part No.  |          | 62                              | 61                            | 64                             |
|-----------|----------|---------------------------------|-------------------------------|--------------------------------|
| Part      |          | Casing bolts                    | Set screw                     | Base bolts                     |
| Pump Size |          |                                 |                               |                                |
| MMP       | 11<br>22 | M6/<br>3.54ft-lb<br>(4.8N•m)    | M6/<br>1.77 ft-lb<br>(2.4N•m) | M8/<br>8.85 ft-lb<br>(12.0N•m) |
|           | 21       | M8/<br>8.85 ft-lb<br>(12.0 N•m) |                               |                                |

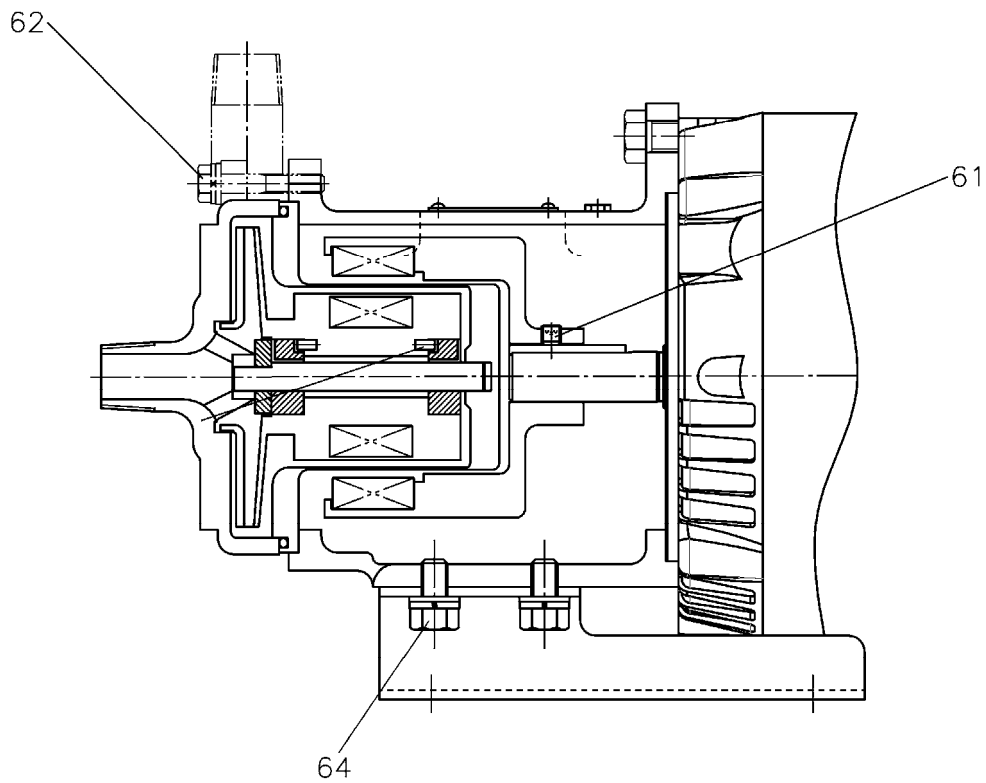

# Troubleshooting

The following table shows common problems as well as their causes and corrective action. Refer to this table in the event of a problem. (“o” indicates a problem that is specific to magnet drive pumps.)

| Problem   | Cause  | Corrective action                         |
|---|--|---|
| Pump does not start up.                                       | ● Motor failure  | ● Repair motor                            |
|   | ● Problem with power supply                                    | ● Inspect                                 |
|   | ● Rotating parts have rusted and motor seizure has occurred    | ● Disassemble and repair                  |
|   | ● There is foreign matter caught in sliding sections           | ● Remove foreign matter                   |
|   | ○ SiC bearings are broken.                                     | ○ Disassemble and replace SiC bearings.   |
| Magnet coupling has slipped.                                  | ○ Magnets have become demagnetized.                            | ○ Replace coupling.                       |
|   | ○ Liquid-specific gravity or viscosity is too high.            | ○ Replace with a high-torque coupling.    |
|   | ○ Power or voltage is too high.                                | ○ Replace with a more appropriate motor.  |
|   | ○ Motor output is too high.                                    | ○ Replace with a more appropriate motor.  |
| Liquid comes out at first but then stops soon after.          | ● Not enough priming water                                     | ● Supply sufficient priming water.        |
|   | ● Pump is taking in air.                                       | ● Inspect suction pipe.                   |
|   | ● Suction head is too high.                                    | ● Reduce suction head.                    |
|   | ○ Magnet coupling is slipping.                                 | ○ See “Magnet coupling has slipped.”      |
| Specified flow rate and specified pump head are not attained. | ● There is foreign matter clogging the strainer or foot valve. | ● Disassemble and clean.                  |
|   | ● Impeller is clogged.   | ● Remove foreign matter.                  |
|   | ● Pump is taking in air.                                       | ● Inspect suction pipe.                   |
|   | ● Rotation in wrong direction.                                 | ● Change electrical connections.          |
|   | ● Pipe loss is great.  | ● Reconsider planning.                    |
|   | ● Liquid temperature is high or liquid is volatile.            |   |
|   | ● Cavitation is being produced.                                | ● Investigate suction conditions.         |
|   | ● Pipe is clogged.   | ● Remove foreign matter.                  |
|   | ● Speed of rotation is too low.                                | ● Investigate using a revolution counter. |
|   | ● Voltage is decreasing.                                       | ● Check power supply.                     |
|   | ● Intake port on positive pressure pumping tank is blocked.    | ● Remove foreign matter.                  |
| Overload  | ● Pump head is low and flow rate is too high.                  | ● Reduce discharge valve opening.         |
|   | ● Specific gravity or viscosity of liquid is too high.         | ● Reconsider planning.                    |
|   | ● Irregular contact at rotating parts.                         | ● Repair or replace parts.                |
|   | ○ SiC bearings are broken..                                    | ○ See “SiC bearing breakage.”             |
| Problem   | Cause  | Corrective action                         |

|   |  |   |                                   |
|---|--|---|-----------------------------------|
| Pump vibrates and considerable noise is produced. | ● Impeller is clogged.   | ● Remove foreign matter.  |                                   |
|   | ● Cavitation is being produced.  | ● Investigate suction conditions.                                 |                                   |
|   | ● Flow rate is too high.   | ● Reduce discharge valve opening.                                 |                                   |
|   | ● Rotation is in the wrong direction.  | ● Inspect electrical connections.                                 |                                   |
|   | ● Pipes are vibrating sympathetically.   | ● Modify piping.  |                                   |
|   | ● Irregular contact at rotating parts  | ● Have the unit repaired at a specialist repair shop.             |                                   |
|   | ● Pump has been operated in shut-off status for a long period of time.   | ● Stop shut-off operation.  |                                   |
|   | ● Bearings are damaged.  | ● Replace bearing parts.  |                                   |
|   | ○ Magnet coupling is slipping.   | ○ See "Magnet coupling has slipped."                              |                                   |
|   | ○ SiC bearings are broken.   | ○ See "SiC bearing breakage."                                     |                                   |
| Magnets are demagnetized.                         | ○ Pump has been operated in no-load status.  | ○ Replace coupling.   |                                   |
|   | ○ Pump has been operated in shut-off status for a long period of time.   |   |                                   |
|   | ○ Liquid has coagulated and pump has been operated after magnet coupling has slipped.  |   |                                   |
| SiC bearing breakage                              | ○ Pump has been operated in no-load status. (You have forgotten to fill pump with liquid, suction valve has been left close, direction of rotation has been checked without filling with liquid, etc.) | ○ Replace SiC bearings.   |                                   |
|   | ○ Pump has been started up without removing all of the air.  |   |                                   |
|   | ○ Pump has been operated in shut-off status for a long period of time.   | ○ Change pipe and perform Net Positive Suction Head (NPSH) check. |                                   |
|   | ○ Pump was operated while cavitation was occurring.  |   |                                   |
|   | ○ There is a solid object or foreign matter caught in the mechanism.   |   | ○ Clean and replace SiC bearings. |
|   | ○ Liquid has coagulated and pump operation has been continued.   |   |                                   |

---

# Repair and Warranty

---

Sanwa Hydrotech Corporation provides repair and maintenance service for your Sanwa Magnet Drive Pump. Terms and conditions of repair and warranty are stated thereto:

## 1. Warranty Repair

Equipment failure and/or damage resulting from defective design or workmanship shall be repaired at no cost to the owner. This warranty repair shall not cover failure and/or damage of equipment resulting from improper usage, long-term storage, natural disasters, accidents or unauthorized modification/attachment on/to the equipment.

## 2. Repair With Charge

The following repairs or parts replacements are available for a fee:

- 2-1) Equipment failure or damage occurring after the period of guarantee expires
- 2-2) Equipment failure or damage occurring as a result of improper usage or long-term storage
- 2-3) Equipment failure or damage occurring as a result of natural disaster, fire or unpreventable accident
- 2-4) Equipment failure or damage occurring as a result of repairs or modifications performed by anyone other than Sanwa Hydrotech Corp., or contractor appointed by Sanwa Hydrotech Corp.,

## 3. Sanwa Hydrotech Corporation shall not assume responsibility for expenses or damage incurred as a result of failure of this product while being used.



If you have any questions regarding this product, please contact Iwaki America, Inc. at the contact numbers or addresses listed below.

## **IWAKI AMERICA, INC.**

Five Boynton Avenue, Holliston, MA 01746 USA

Tel: 508-429-1440 / [info@iwakiamerica.com](mailto:info@iwakiamerica.com) / [iwakiamerica.com](http://iwakiamerica.com)