

MISSION PRODUCTS

CENTRIFUGAL PUMPS

MAGNUM™, 2500 SUPREME™, MAGNUM XP™, SANDMASTER™



The Evolution

During the 1950's the Mission™ 1780 type “W” pumps were introduced to replace duplex pumps while creating the first low pressure mud system. The use of a high quality concentric type centrifugal pump allowed abrasive fluids to be mixed and transferred while reducing initial and maintenance costs for the drilling industry. The low-pressure mud system with Mission 1780 Type “W” centrifugal pumps became the industry standard.

As well depths increased so did the need for heavier mud weights. When the mud weight began exceeding 14 ppg the need for a pump that could withstand greater horsepower loads arose. During the 1970's Mission organized a design team that engineered the Mission Magnum. The Magnum was designed to have the same footprint, flange locations, and drive shaft diameter as the 1780 “W”. This allowed a 1780 to be replaced by a Magnum without any skid modifications. The Magnums were originally engineered with a 2-1/2" shaft (3" between the bearings), double row bearings with an engineered life of over 2 years at 200 HP, larger impellers and heavier frames. The Magnum allowed drilling contractors to upgrade their centrifugal pumps and mix heavier fluids.

The National Oilwell Varco® Mission centrifugal pump line has proven to be the best centrifugal design for handling abrasive mud. This pump line offers a broad selection of innovative features for a variety of routine, demanding, abrasive and corrosive applications. These pumps are designed for a wide range of flow rates, from a few gallons per minute to thousands of gallons per minute.

NOV® is dedicated to continual improvement of our product line and offering innovative solutions to service our customers. Included in this manual are quality NOV products that have been designed to meet your needs. The future is being defined and the solution is available from NOV.



MISSION™ PRODUCTS

**This catalog has been divided into eight major sections.
Each section has been color coded for convenience.**

Mission Magnum and 2500 Supreme Pumps	2-14
Sandmaster, Vortex and Magnum XP Pumps	15-18
Shear Pumps	19-20
Pump Sizing Information	21-26
Pump Performance Curves	27-45
Dimensional Data	46-51
Piping Recommendations	52-53
Related Equipment	54-55
Close Coupled Centrifugal Pumps	56
Conversion Table	57

The pictures, photographs, charts, diagrams, drawings, written comments and specifications contained herein are not to be construed as giving rise to any warranty on the part of Mission, a product of National Oilwell Varco. Mission makes no warranty, either expressed or implied, beyond that stipulated in the Mission Standard Terms and Conditions of Sale.

Mission Magnum and 2500 Supreme Pumps

Features of the Magnum™, 2500 Supreme™, and Sandmaster™ Pumps

Each pump contains the finest materials, engineering and craftsmanship available in the industry. Described are like features of these pump lines and unique features are described on the following pages.

National Oilwell Varco utilizes unique design features developed for slurries. Three major differences from most pump designs include the concentric casing, wider impellers and increased re-circulation areas. Each feature contributes to reducing wear when handling abrasive fluids.

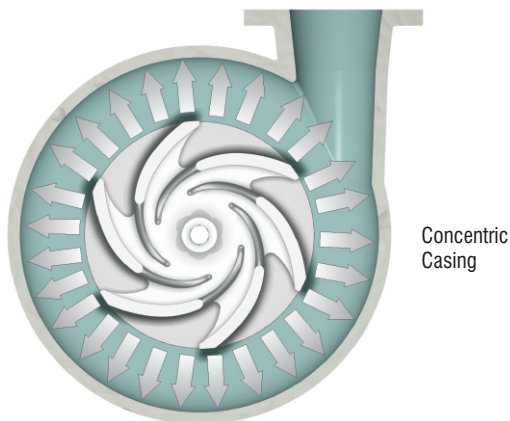
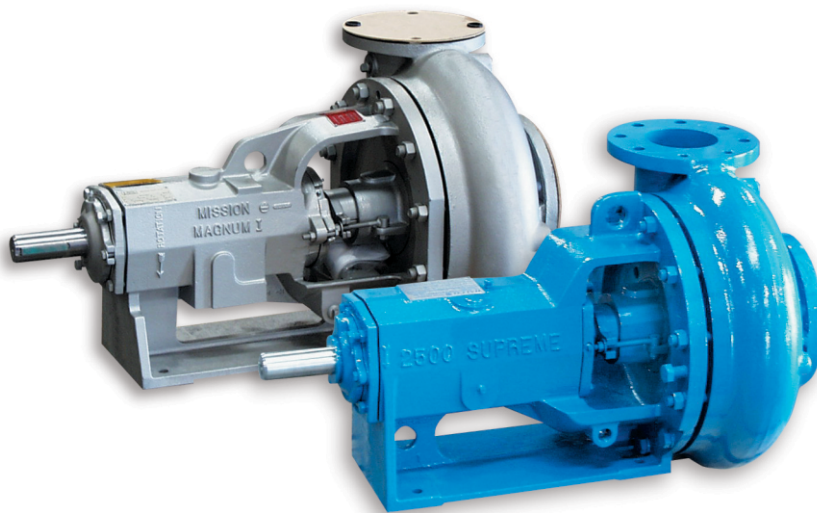

Concentric Casing

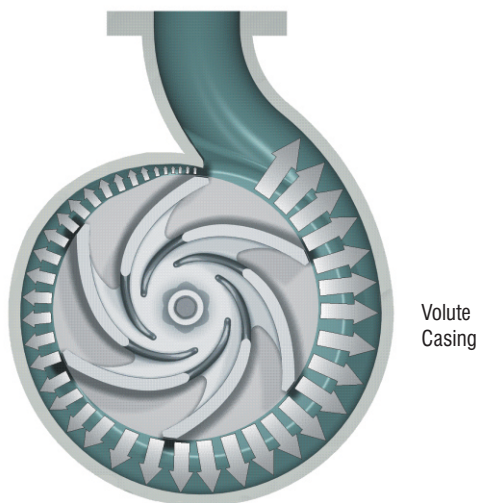

Volute Casing

Thicker, Stronger, Concentric Casing

All of the pumps feature a concentric casing. This casing averages 37% thicker than conventional pump casings, and up to 50% thicker for the larger, mud pumping models. They are pressure rated at 1.5 times the flange rating and are designed with a 1/8" erosion allowance. The concentric style casing has proven to offer the greatest pump life and reduced downtime. The walls of a concentric style casing are an equal distance from the impeller throughout the impeller circumference, which results in a smooth flow pattern. A volute style casing has a cutwater point that disturbs the fluid flow pattern creating an eddy. The concentric casing eliminates vibration, turbulence and aeration that is caused by the cutwater point in conventional volute pumps. It also reduces the high bearing loads and shaft deflection even at near shutoff flows.

Wider Impeller, Increased Re-circulation Area

National Oilwell Varco's impeller design has wider vanes at the tip which decreases the velocity of the fluid exiting the impeller. This eliminates the abrasive jetting effect that is present with narrow impellers. The distance between the impeller tip and the casing is greater resulting in an increased re-circulation area. Lower velocity rates and increased re-circulation areas allow the exiting fluid to blend with the re-circulating fluid reducing turbulence and wear. The entrance shape of the impeller vanes is more tangential to the circumference of the suction creating a smoother flow pattern. Smooth flow is crucial when handling abrasive fluids.

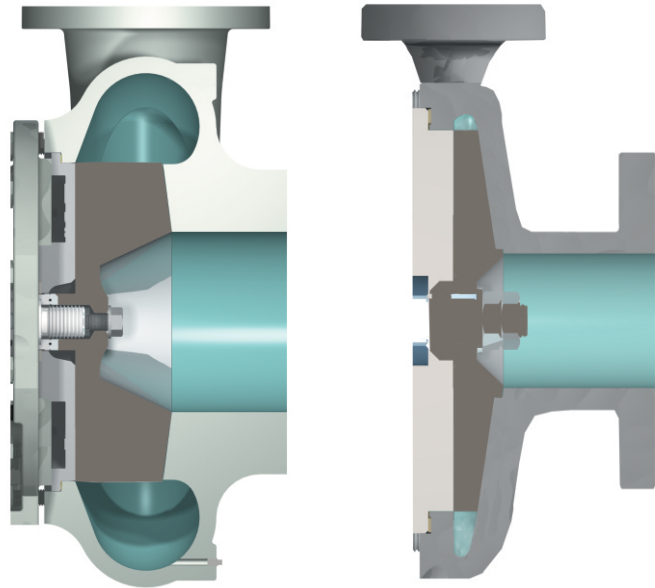

Wide Tipped Impeller

ANSI Style Impeller

Heavy-Duty Shaft

The shaft is much larger in diameter than conventional pump shafts for heavy-duty performance, minimum deflection and increased operating life of the seal or packing. With a 2-1/2" diameter at the seal area and 3" diameter between the bearings these pumps can be direct connected or belt driven.

The shaft area under the packing is protected by a replaceable, hook type sleeve with one end free to expand with temperature variation. This sleeve can be replaced in the field without shaft removal.

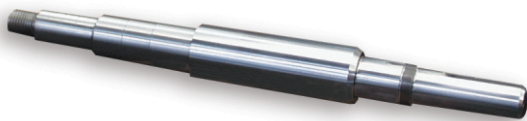

Highest Quality Bearings

Advanced front and rear bearing design reduces both radial and thrust loads. The outboard bearing is a duplex set of angular contact bearings with high thrust load capabilities and zero endplay. This bearing set features 24 large balls that are preloaded so that each bearing carries an equal load.

National Oilwell Varco utilizes an inboard bearing that is a single row roller bearing with high radial load capabilities. This bearing was selected to replace the previously utilized double row bearing due to its engineered bearing life of over 2.2 times the L10 life of previously utilized double row ball bearings.

Bearing Lubrication Options

Oil or grease lubrication is available. Grease lubrication is the factory standard. Oil lubrication is recommended for pump speeds in excess of 2400 RPM. Oil lubricated pumps must be maintained in a horizontal level position.

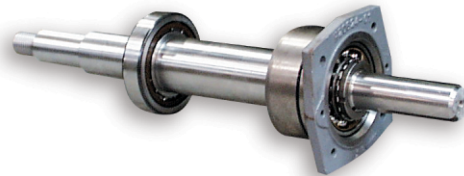

Mechanical Seal Options

A type I single tungsten carbide vs. tungsten carbide mechanical seal is standard. Tungsten carbide has proven itself as a highly abrasive resistant material with a Ph range of 7 to 14, depending on chemical composition. For applications with a lower Ph level the silicon carbide vs. silicon carbide mechanical seal is recommended with its Ph range from 0-14, depending on chemical composition. Both mechanical seals are lubricated by the fluid being transferred and require the pump to remain primed during operation.

When the pump is subject to high temperature fluids, oil base muds with low aniline points, running dry or extremely abrasive fluids, the Olympia™ cartridge type double mechanical seal is the solution. Utilizing a barrier fluid between the two seals ensures the seal faces remain lubricated even when the pump is run dry. The fluid being transferred has virtually no effect on the seal since the barrier fluid is in contact with the seal faces.

Custom mechanical seal options can be provided for specific applications.

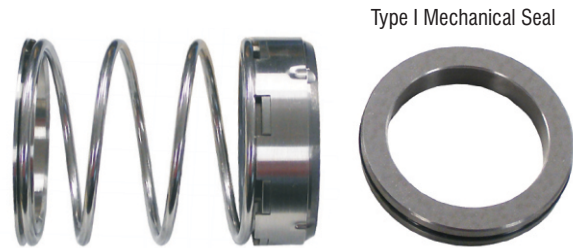

Type I Mechanical Seal

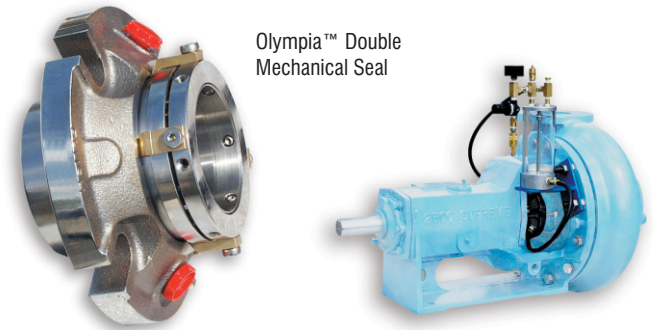

Olympia™ Double Mechanical Seal

Centrifugal Equipped with Olympia Seal

Stuffing Box with Dual Bolt Holes

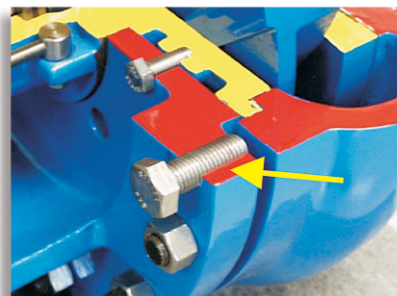
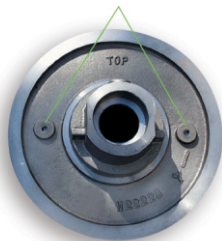

Versatile Stuffing Box

An easily removable stuffing box allows these pumps to be customized to meet customer needs. The different options available are stuffing boxes to accommodate:

- Shaft packing
- Single mechanical seal
- Olympia™ Double mechanical seal with barrier fluid
- Specialized mechanical seals

The packed box has a tapped opening to the lantern ring to allow grease lubrication or a flush line to be attached.

Dual stuffing box bolts are positioned 180 degrees apart to hold the stuffing box in position during casing removal. When only one stuffing box bolt is used the stuffing box remains in position on one side while the other side moves with the casing, causing the casing to bind and make removal difficult.

Casing Jack Bolts

Casing jack bolts are an added feature to the Magnum and 2500 Supreme pump lines. Jack bolts allow the casing to be mechanically removed eliminating the need for pry bars or striking the casing during maintenance. This feature simplifies maintenance and eliminates damage to the casing and pedestal during disassembly.

Solid Frame Base

The solid frame base strengthens the pump and eliminates broken feet that occur with pumps equipped with a split base.

Fluid End Materials

Various fluid end materials are available that allow these pumps to be utilized for a variety of applications. Standard pumps are supplied with a hard iron fluid end but can be upgraded to stainless steel, aluminum bronze, Magnachrome™, or Supreme Hard. These materials are available for select sizes and can be purchased as a complete or fitted fluid end.

Magnachrome material is a proprietary material exclusive to National Oilwell Varco and is formulated specifically for its high abrasion resistant qualities. Magnachrome is approximately 3 times harder than Hard Iron. The Supreme Hard material is approximately 2 times harder than Hard Iron.

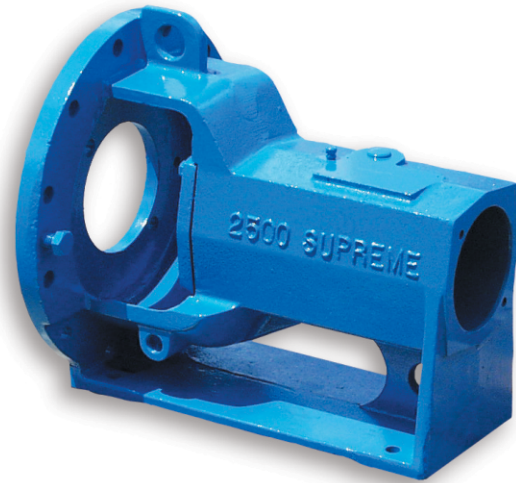

Technical Support and Parts Availability

With locations and distributors throughout the world, National Oilwell Varco ensures our customers can obtain technical assistance and pump parts in a timely manner. Engineering support, literature and electronic manuals are available to help properly size and service equipment.

Superior Packaging and Labeling

All parts are properly packaged to protect the equipment during shipping. The material is clearly marked to ensure our customers are getting OEM manufactured parts and allow packers and service hands to confirm they have the correct equipment without having to open the packaging and expose the equipment to external elements.

Magnum and 2500 Supreme

National Oilwell Varco is dedicated to providing a full line of products to meet the needs of our customers. Realizing customer needs and priorities may differ, National Oilwell Varco provides two separate pump lines with like operating and dimensional characteristics. Following are the unique features of the Magnum and 2500 Supreme.

Magnum*	2500 Supreme*
Open impeller design that lowers axial thrust loads and is equipped with an impeller retention bolt to ensure the pump is not damaged if run in reverse. (Impeller retention bolt is not available on 3x2x13 models.)	Semi Open impeller design that reduces the amount of solids that enter the stuffing box extending the life of the mechanical seal or packing and the life of the stuffing box. (Available on 5x4x14 – 10x8x14 models.)
Lip seals and exclusion seal to retain lubricants and protect bearings from external contamination	Labyrinth seals to offer maximum bearing protection from external contamination. Labyrinth seals rotate with the shaft eliminating shaft wear.
Fluid end parts available with Magnachrome corrosive and abrasive resistant material. Magnachrome impellers have a 400 Brinell hardness and Magnachrome casings and stuffing boxes feature a 600 Brinell hardness.	Fluid end parts available with Supreme Hard material that has a 400 Brinell hardness. The standard impeller, casing wear pad and stuffing box are Ductile Iron to ensure even wear characteristics.
One piece casing	Casing provided with replaceable casing wear pad on 4x3x13 – 10x8x14 models.

* The Magnum and 2500 Supreme are available through select distributors.

Magnum Features

- 1 Thick, strong concentric casing provides extended life over conventional volute designs. The concentric design minimizes turbulence and abrasive wear.
- 2 Wide open-vane impeller increases flow and creates lower axial thrust for improved bearing life.
- 3 Casing gasket recessed for protection.
- 4 Replaceable stuffing-box cover with dual stuffing box bolts
- 5 Optional stuffing boxes available for single and double mechanical seal applications and can be configured for flush lines.
- 6 Long-life no-adjustment mechanical seal available for near zero leakage.
- 7 Replaceable shaft sleeve prevents shaft wear.
- 8 Single row roller bearings for increased bearing life.
- 9 Oil lubrication for bearings available upon request and recommended for pump speeds in excess of 2400 RPM.
- 10 Duplex angular contact bearings eliminate shaft end play and increases bearing and seal life.
- 11 Lip and exclusion seals for bearing protection
- 12 Optional flanged bearing housing available for hydraulic drive
- 13 External adjustment of impeller clearance extends pump performance life.
- 14 Large heavy-duty shaft reduces deflection for longer life of packing and mechanical seals.
- 15 Solid base offering rigidity and strength
- 16 Casing jack bolts simplify casing removal
- 17 Easily accessible front access drain, when requested.
- 18 Back vanes reduce collection of solids at stuffing box and reduce box pressure.
- 19 Smooth impeller eye for minimum turbulence and higher efficiency.
- 20 Anti-loosening impeller lock bolt to eliminate pump damage in case of improper motor hook-up.
- 21 Full pipe diameter entrance for minimum turbulence and maximum efficiency.

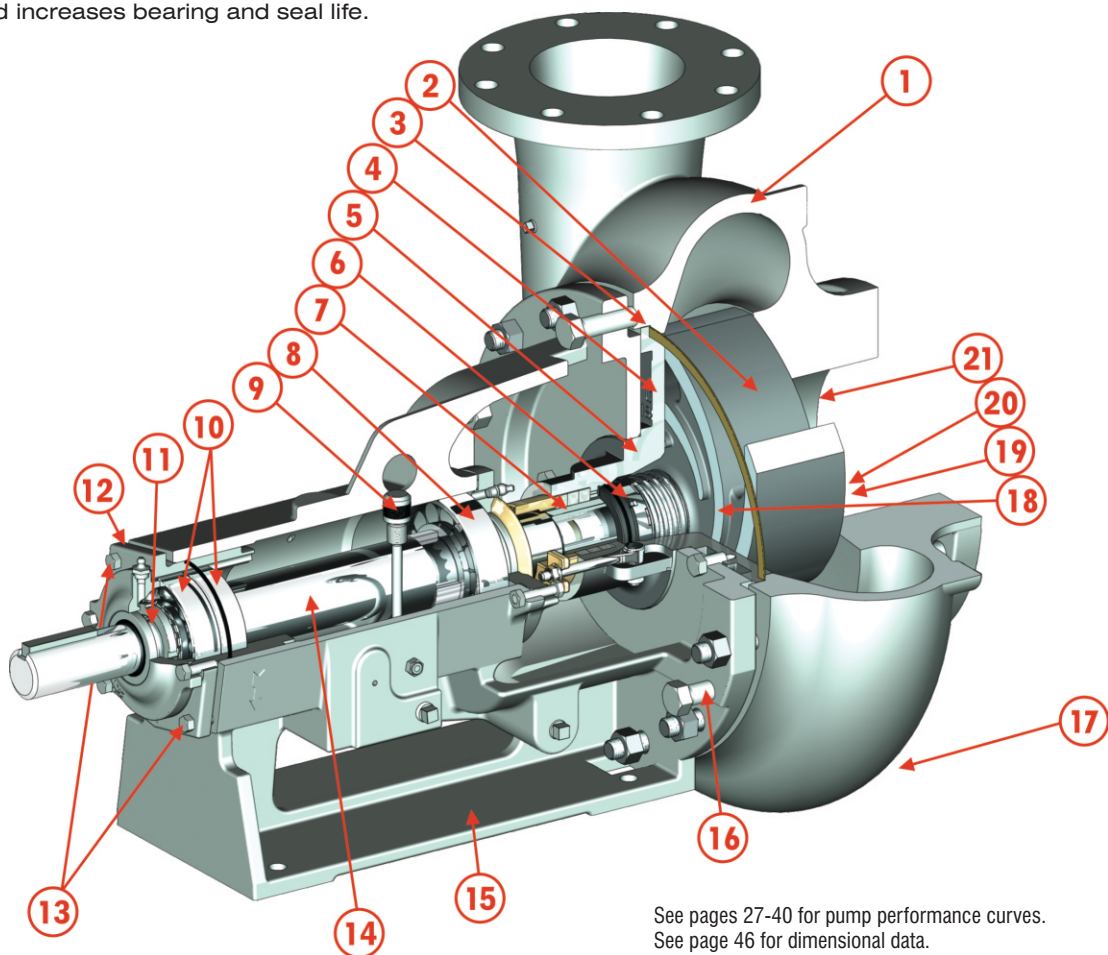

See pages 27-40 for pump performance curves.
See page 46 for dimensional data.

2500 Supreme Features

- 1 Thick, strong concentric casing with replaceable casing wear pad provides extended life over conventional volute designs. The concentric design minimizes turbulence and abrasive wear. The wear pad allows the casing to be repaired at a lower cost than replacing the entire casing.
- 2 Wide semi open impeller creates lower axial thrust for improved bearing life. The semi open design reduces the concentration of solids behind the impeller extending the life of the mechanical seal or packing and stuffing box.
- 3 Casing gasket recessed for protection.
- 4 Replaceable stuffing-box cover with dual stuffing box bolts
- 5 Optional stuffing-boxes available for single and double mechanical seal applications and can be configured for flush lines.
- 6 Long-life no-adjustment mechanical seal available for near zero leakage.
- 7 Replaceable shaft sleeve prevents shaft wear.
- 8 Single row roller bearings for increased bearing life.
- 9 Oil lubrication for bearings available upon request and recommended for pump speeds in excess of 2400 RPM.
- 10 Duplex angular contact bearings eliminate shaft end play and increases bearing and seal life.
- 11 Labyrinth seals for maximum bearing protection are standard. Lip seals are recommended for oil-lubricated pumps.
- 12 Optional flanged bearing housing available for hydraulic drive.
- 13 External adjustment of impeller clearance extends pump performance life.
- 14 Large heavy-duty shaft reduces deflection for longer life of packing and mechanical seals
- 15 Solid base offering rigidity and strength
- 16 Casing jack bolts simplify casing removal
- 17 Replaceable casing wear pad.
- 18 Easy accessible front access drain.
- 19 Back vanes reduce collection of solids at stuffing box and reduce box pressure.
- 20 Smooth impeller eye for minimum turbulence and higher efficiency.
- 21 Full pipe diameter entrance for minimum turbulence and maximum efficiency.

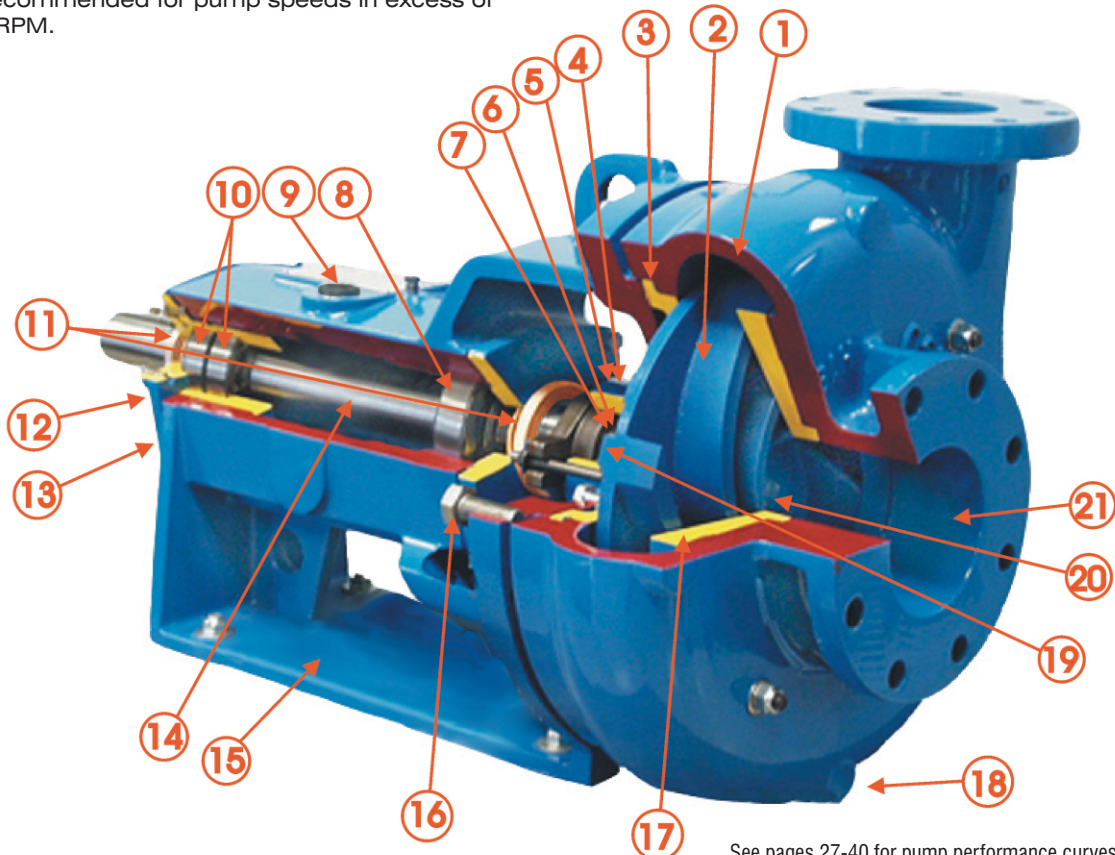

See pages 27-40 for pump performance curves.
See page 46 for dimensional data.

Magnum Centrifugal

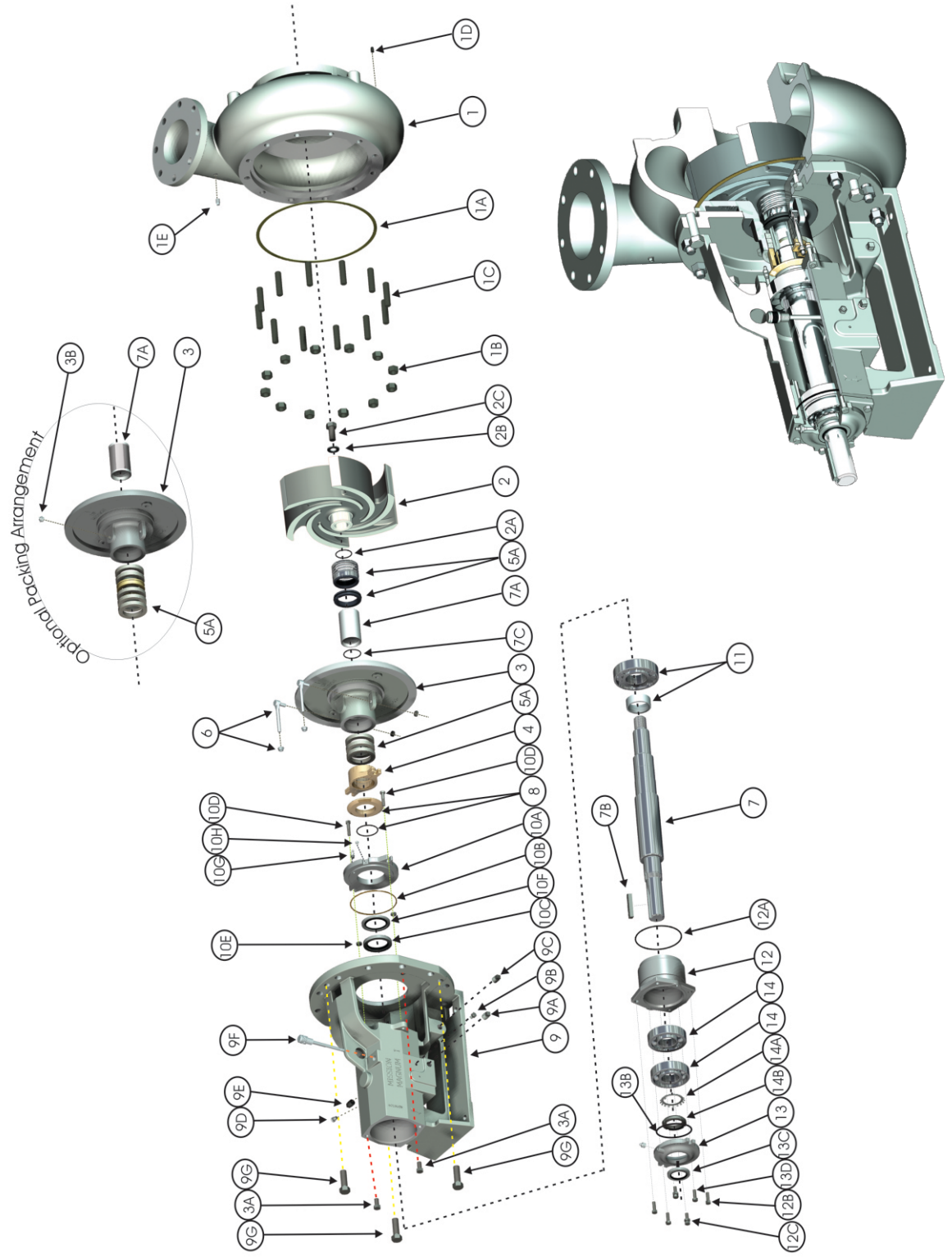

Magnum Parts List

Item	Qty	Catalog Number	Part #	Description	Material
1*	1	See Below	See Below	Casing	Hard Iron
1A	1	10399-46-1	648403012	Gasket, Casing	Vellumoid
1B	12	3932-61	648402014	Nut, Casing	Stl
1C	12	3862-76	648401115	Stud, Casing	Stl
1D	1	8505-04-01	86485503	Plug, Casing Drain	Stl
1E	1	8505-04-01	646400507	Plug, Flush Line	Iron
2*	1	See Below	See Below	Impeller	Hard Iron
2A	1	19110-72	648405082	Seal, Impeller	Viton
2B	1	7300239	7300239	Washer, Impeller	Stl
2C	1	7415648	7415648	Bolt, Impeller Lock	Stl
3*#	1	22223-01-30	641116157	Stuffing box, Mech. Seal	Hard Iron
3*&	1	20614-01-30	643365042	Stuffing Box, Packed	Hard Iron
3A	2	3861-117	648401016	Bolt, Stuffing box	Stl
3B&	1	19368-01	601499403	Grease Fitting	Stl
4	1	20622A	641103338	Gland Assy., Packing	Bronze
5A#	1	22451-1	648414308	Seal, Mechanical	Tungsten Carbide
5A~	1	25014-04M-B	661007005	Packing, Shaft	Graphite/Acrylic
6	2	B3701A	601102494	Bolt Assy, Gland	Stl
7	1	20612-02-33	646490557	Shaft	AISI 4140
7A#	1	20943-21	641102182	Sleeve, Shaft (M.S. Pump)	416SS
7A&	1	20613-21G-7A	641102181	Sleeve, Shaft (Pack Pump)	416SS/Ceramic
7B	1	4372-5-21	601212392	Key, Shaft	416SS
7C	1	23444-01-72	648415156	Seal, Shaft Sleeve	Viton
8	1	22210-1A	641116108	Deflector Assembly	Bronze
9	1	20618-12-1	644302499	Frame, Grease Lubricated	Cast Iron
9A!	1	8505-05	601474737	Plug, Oil Drain	Iron
9B!	1	18471	648403608	Plug, Oil Fill	Iron
9C	1	8505-05	601474737	Plug, Frame Drain	Iron
9D	1	8267-01	601473689	Breather	Stl
9E	1	8478-3	601174584	Oiler Assembly	Stl
9F	1	A 662014131	662014131	Dip Stick	Stl
9G	3	2538-1H	644303109	Bolt, Casing Jack	Stl
10A	1	20626	648408706	Cover, Inboard Bearing	Iron
10B	1	20625	648408706	Gasket, I.B. Brg. Cover	Vegetable Fiber
10C	1	20619-01	648408300	Oil Seal, I.B. Brg. Cover	Buna-n
10D	2	3861-1	601407505	Bolt, I.B. Brg. Cover	Stl
10E	2	3932-2	601408560	Nut, I.B. Brg. Cover	Stl
10F	1	20620-01	648408409	Exclusion Seal, I.B. Brg. Cvr.	Buna-n
10G	1	21641-01	661010033	Grease Fitting	Stl
10H	1	N/A	648411908	Grease Fitting	Stl
11	1	N/A	661009010	Bearing, Inboard	Vendor
12	1	20624-01-01	644308504	Housing, O.B. Bearing	Iron
12A	1	7496-253	648402295	Seal, O.B. Brg Housing	Buna-n
12B	4	3861-138	648401057	Bolts, O.B. Brg. Housing	Stl
12C	2	3932-62	658404702	Nut, O.B. Brg. Housing Jam	Stl
13	1	20617-01-01	641103296	Cover, O.B. Bearing	Iron
13A	1	7496-26	072200017	Grease Zerk, O.B. Brg. Cvr.	Stl
13B	1	20619-02	648408359	O-ring, O.B. Bearing Cover	Buna-n
13C	2	3861-139	648401081	Bolt, O.B. Brg. Cover	Stl
14	2	N/A	648408201	Bearing, O.B. (2 Req'd)	Vendor
14A	1	6124-4	648402105	Lockwasher, O.B. Bearing	Stl
14B	1	6123-4	648402055	Lucknut, O.B. Bearing	Stl
Casings - Includes Studs, Nuts and Gasket					
1*	1	19203-01-30A	641101753	Casing, 3x2x13	Hard Iron
1*	1	19205-01-30A	641101902	Casing, 4x3x13	Hard Iron
1*	1	19222-01-30A	641102058	Casing, 5x4x14	Hard Iron
1*	1	19122-01-30A	641101456	Casing, 6x5x11	Hard Iron
1*	1	19123-01-30A	641101605	Casing, 6x5x14	Hard Iron
1*	1	19768-01-30A	641102157	Casing, 8x6x11	Hard Iron
1*	1	19117-01-30A	641101308	Casing, 8x6x14	Hard Iron
1*	1	20937-01-30A	641102322	Casing, 10x8x14	Hard Iron
Impellers					
2*	1	19204-XX-30	Varies	Impeller, 3x2x13	Hard Iron
2*	1	19206-XX-30	Varies	Impeller, 4x3x13	Hard Iron
2*	1	19224-XX-30	Varies	Impeller, 5x4x14	Hard Iron
2*	1	19121-XX-30	Varies	Impeller, 6x5x11	Hard Iron
2*	1	19121-XX-30	Varies	Impeller, 6x5x14	Hard Iron
2*	1	19121-XX-30	Varies	Impeller, 8x6x11	Hard Iron
2*	1	19116-A0-30	Varies	Impeller, 8x6x14	Hard Iron
2*	1	21867-XX-30	Varies	Impeller, 10x8x14	Hard Iron

XX - Impeller Code - First X equals diameter of impeller in inches minus 4. Therefore 10" = 6, 9" = 5, 8" = 4, etc... 14" use letter A.
 Second X equals fractional data in 1/8's. Therefore 1/8" = 1, 1/4" = 2, 1/2" = 4, etc... Thus a 10.5" impeller is coded as 64, a 12" impeller is coded as 80, a 13.25" impeller is coded as 92 etc.

Notes:

- * - Casings, Impellers and Stuffing Boxes are also available as Stainless Steel, Aluminum Bronze or Magnachrome - See local dealer for Part Numbers.
- # - Used for pumps equipped with mechanical seal only.
- & - Used for pumps equipped with packing only.
- ! - Used for oil lubricated pumps only.
- ~ - Packing available in various materials - standard material shown



2500 Supreme

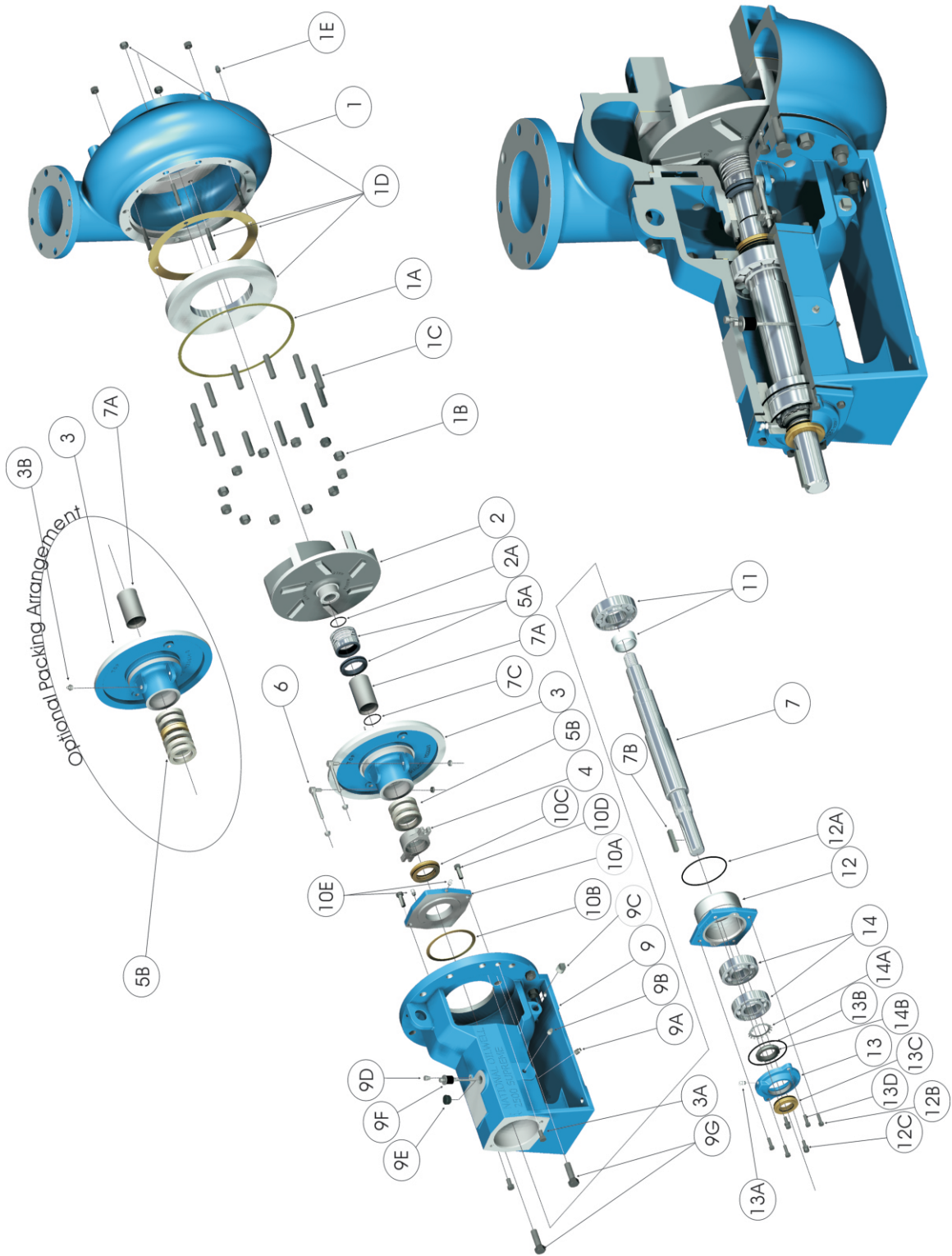

2500 Supreme Parts List

Item	Qty	Catalog Number	Part #	Description	Material
1*	1	See Below	See Below	Casing, Includes 1 thru 1E	Hard Iron
1A	1	10399-46-1	648403012	Gasket, Casing	Vellumoid
1B	12	3932-61	3932-61H	Nut, Casing	Stainless Steel
1C	12	H2507-3	648401115	Stud, Casing	Stl
1D*	1	See Below	See Below	Wear Pad, Includes studs, nuts, & gskt	
1E	1	8505-2H	601474703	Plug, Casing Drain	Stl
2*	1	See Below	See Below	Impeller	Hard Iron
2A	1	H19110-72	648405082	Seal, Impeller	Viton
3*#	1	H22223-01-30	22223H	Stuffing box, Mech. Seal	Ductile Hard Iron
3*&	1	H20614-01-30	20614H	Stuffing Box, Packed	Ductile Hard Iron
3A	2	H3861-117	3861-138	Bolt, Stuffing box	Stl
3B&	1	19368-1H	19368-1H	Grease Fitting	Stl
4	2	H20622A	20622H	Gland Assy., Packing	Stainless Steel
5A#	1	H22451-1A	22451K	Seal, Mechanical	Tungsten Carbide
5B~	1	8264-24-0B	648402600	Packing, Shaft	
6	2	20629	601102494	BOLT, GLAND	Stl
7	1	H20612-02-33	646490557	Shaft	AlSI 4140
7A#	1	H20613-21A	646492505	Sleeve, Shaft (M.S. Pump)	416SS
7A&	1	H20613-21G-7A	646490656	Sleeve, Shaft (Pack Pump)	416SS/Ceramic
7B	1	H4372-5-21	601212392	Key, Shaft	416ss
7C	1	23444-01-72	648415156	Seal, Shaft Sleeve	Viton
8	1	22210-1A	641116108	Deflector Assembly	Bronze
9	1	H17444	17444H	Frame, Grease Lubricated	Cast Iron
9A!	1	H8505-1	8505-1	Plug, Oil Drain	Iron
9B!	1	8505-2H	601474703	Plug, Oil	Iron
9C	1		601474737	Plug, Frame Drain	Iron
9D	1	H8267-1	601473689	Breather	Stl
9E	1	H2565-1	2565-1H	Plug, Oil Fill	Plastic
9F!	1	H2539-3	2539-3H	Dip Stick	Stl
9G	2	H2538-1	2538-1H	Bolt, Casing Jack	Stl
10A	1	H17950	17950H	Cover, Inboard Bearing	Iron
10B	1	H20625	648408706	Gasket, I.B. Brg. Cover	Vegetable Fiber
10C	1	H2564-4	2564-4H	Labyrinth Seal, IB Brg Cvr	Buna-n
10D	2	H3861-1	3861-1H	Bolt, I.B. Brg. Cover	Stl
10E	1		661010033	Grease Fitting	Stl
11	1	N/A	661009010	Bearing, Inboard	Vendor

Item	Qty	Catalog Number	Part #	Description	Material
12A	1	H7496-253	648402295	Seal, O.B. Brg. Housing	Buna-n
12B	4	H3861-138	3861-138	Bolts, O.B. Brg. Housing	Stl
12C	2	H3932-62	658404702	Nut, O.B. Brg. Housing, Jam	Stl
13	1	H20617A	20617H	Cover, O.B. Bearing	Ductile Iron
13A	1	661010020		Grease Zerf, O.B. Brg. Cvr.	Stl
13B	1	H7496-26	072200017	O-ring, O.B. Bearing Cover	Buna-n
13C	1	H2564-3	2564-3H	Labyrinth Seal, O.B. Brg. Cvr.	Buna-n
13D	2	H3861-139	3861-139-4	Bolt, O.B. Brg. Cover	Stainless Steel
14	2	H20616-1S	648408201	Bearing, O.B. (2 Req'd)	Vendor
14A	1	H6124-4	648402105	Lockwasher, O.B. Bearing	Stl
14B	1	H6123-4	648402055	Locknut, O.B. Bearing	Stl
Casings - Includes Studs, Nuts and Gasket					
1*	1	H19203-01-30A	19203AH	Casing, 3x2X13	Hard Iron
1*	1	H19205-01-30A	19205AH	Casing, 4x3X13, w/ wear pad	Hard Iron
1*	1	H19222-01-30A	19222AH	Casing, 5x4X14, w/ wear pad	Hard Iron
1*	1	H19122-01-30A	19122AH	Casing, 6x5X11, w/ wear pad	Hard Iron
1*	1	H19123-01-30A	19123AH	Casing, 6x5X14, w/ wear pad	Hard Iron
1*	1	H19783-01-30A	19783AH	Casing, 8x6X11, w/ wear pad	Hard Iron
1*	1	H19117-01-30A	19117AH	Casing, 8x6X14, w/ wear pad	Hard Iron
1*	1	H20937-01-30A	20937AH	Casing, 10x8X14, w/ wear pad	Hard Iron
Impellers and Casing Wear Pads					
2*	1	H19204-XX-30	Varies	Impeller, 3x2X13 Open	Ductile Hard Iron
2*	1	H19206-XX-30	Varies	Impeller, 4x3X13 Open	Ductile Hard Iron
2*	1	H2523-XX-30	Varies	Impeller, 5x4X14 Semi Open	Ductile Hard Iron
2*	1	H2524-XX-30	Varies	Impeller, 6x5X11 Semi Open	Ductile Hard Iron
2*	1	H2524-XX-30	Varies	Impeller, 6x5X14 Semi Open	Ductile Hard Iron
2*	1	H2525-AD-30	Varies	Impeller, 8x6X11 Semi Open	Ductile Hard Iron
2*	1	H2525-AD-30	Varies	Impeller, 8x6X14 Semi Open	Ductile Hard Iron
2*	1	H2526-XX-30	Varies	Impeller, 10x8X14 Semi Open	Ductile Hard Iron
1E	1	H2501-01-30A	2501-37AH	Wear Pad, 4X3X13 Casing	Ductile Hard Iron
1E	1	H2502-01-30A	2502-37AH	Wear Pad, 5X4X14 Casing	Ductile Hard Iron
1E	1	H2503-01-30A	2503-37AH	Wear Pad, 6X5X11 Casing	Ductile Hard Iron
1E	1	H2504-01-30A	2504-37AH	Wear Pad, 6X5X14 Casing	Ductile Hard Iron
1E	1	H2505-01-30A	2505-37AH	Wear Pad, 8X6X11 Casing	Ductile Hard Iron
1E	1	H2506-01-30A	2506-37AH	Wear Pad, 8X6X14 Casing	Ductile Hard Iron
1E	1	H2527-01-30A	2527-37AH	Wear Pad, 10X8X14 Casing	Ductile Hard Iron

XX - Imp. Code - First X equals diameter of impeller in inches minus 4. Therefore 10" = 6, 9" = 5, 8" = 4, etc... 14" use letter A. Second X equals fractional data in 1/8's. Therefore 1/8" = 1, 1/4" = 2, 1/2" = 4, etc... Thus a 10.5" impeller is coded as 64

Notes:

- * - Casings, Imp. & Stuff Boxes are available as Supreme Hard or Aluminum Bronze
- # - Used for pumps equipped with mechanical seal only.
- & - Used for pumps equipped with packing only.
- ! - Used for oil lubricated pumps only.
- ~ - Packing available in various materials - standard material shown

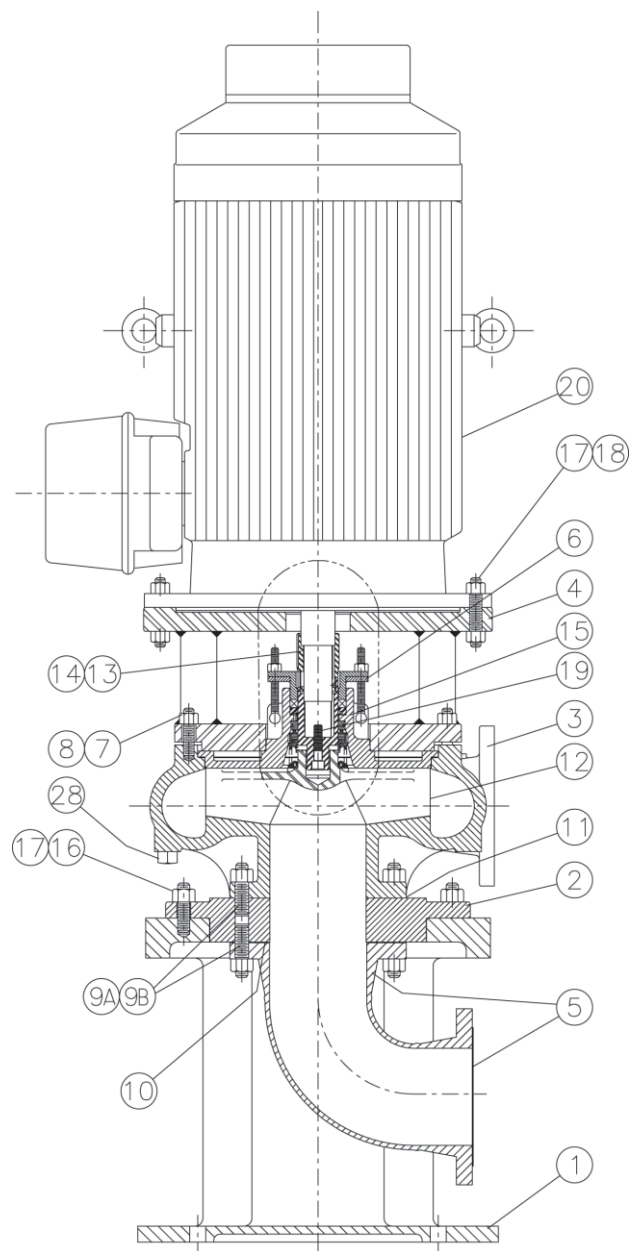
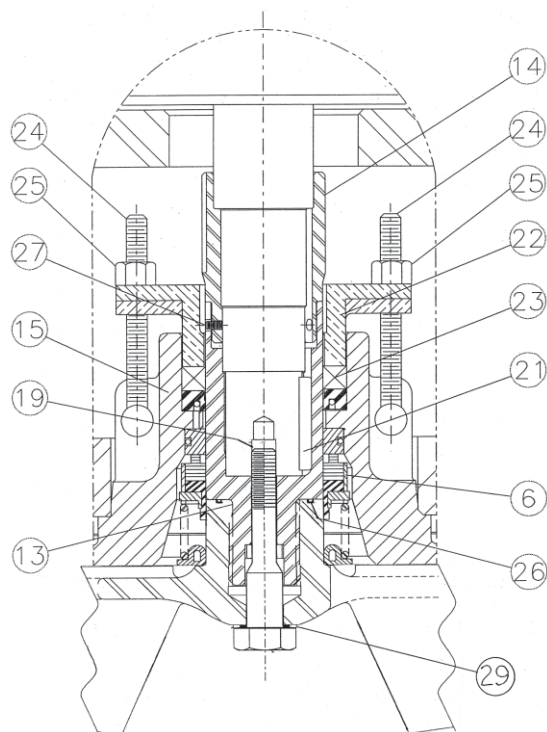

Vertical Magnum Parts List
Parts Common to all Vertical Magnums

Item	Quantity	Part Number	Description
1	1	662014039	Pump-Base
6	1	648414308	Mechanical Seal
7	12	648401115	Casing studs
8	12	648402014	Casing Nuts
11	1	648403012	Casing Gasket
15	1	643367048	Mech Seal Stuffing Box
19	1	662010054	Impeller Retention Bolt
20	1	Contact Factory	Electric Motor
22	1	641103338	Packing Gland
23	1	661007023	Back-up Packing
24 and 25	2	601102494	Gland Bolts
26	1	648405082	Impeller O-ring
27	8	601482417	Set Screw
28	1	646400507	Casing Drain plug
29	1	*	Anti-Spin Bolt Washer
Not Shown	2	648401016	Stuffing Box Bolts

* Contact your National Oilwell Varco representative.

MISSION™ PRODUCTS

Parts Specific by Pump Size

Item #	2	3	5	9B	9A	10	12	16	17
		Casing Assy.							
		H.I. (1)							
	Base	Includes				Suction	H.I. Impeller (1)	Base	Base
Pump	Companion	studs, nuts,	Suction	Suction	Suction	Flange	(P/N varies by	Flange Nut	Flange Stud
Size	Flange (1)	and gasket	Elbow (1)	Flange Nut	Flange Stud	Gaskets (2)	diameter)		
3x2x13	662014044	641101753	665002001	601408552	601408305	601475189	641215603	601408552	601208285
4x3x13	662014043	641101902	665002002	601408552	601408305	601475346	641217005	601408552	601208285
5x4x14	662014042	641102058	665002003	648402014	648401115	601475254	641217831	601408552	601208285
6x5x11	662014041	641101456	665002004	648402014	648401115	601475338	641211602	601408552	601208285
6x5x14	662014041	641101605	665002004	648402014	648401115	601475338	641212105	601408552	601208285
8x6x11	662014040	641102157	665002005	648402014	648401115	601475320	641211602	601408552	601208285
8x6x14	662014040	641101308	665002005	648402014	648401115	601475320	641209903	601408552	601208285
10x8x14		641102322					641221007	601408552	601208285

Parts Specific by Motor Frame Size

Item #	4	14	21	27	30	31	Not Shown
			Shaft				Adapter
			Sleeve	Shaft Sleeve	Motor	Motor	Frame (444
Motor	Motor Frame	Motor Shaft	Shim	Set Screw	Adapter	Adapter	and 445
Frame	Adapter (1)	Sleeve (1)	(1)	(6)	Studs (4)	Nuts (4)	only)
215JP	662014045	662013009	662014218	75634012	601408412	658404702	
254JP	662014045	662013009	662014218	75634012	601408412	658404702	
256JP	662014045	662013009	662014218	75634012	601408412	658404702	
284JP	662014055	662013009	662014218	75634012	601408305	658404702	
286JP	662014055	662013009	662014218	75634012	601408305	658404702	
324JP	662014055	662013009	662014218	75634012	601408305	601408552	
326JP	662014055	662013009	662014218	75634012	601408305	601408552	
364JP	662014055	646492505	662014218	75634012	601408305	601408552	
365JP	662014055	646492505	662014218	75634012	601408305	601408552	
404TCZ	662014055	646492505	662014218	75634012	601408305	601408552	
405TCZ	662014055	646492505	662014218	75634012	601408305	601408552	
444TCZ	662014055	646492505	662014218	75634012	601408305	601408552	662014057

* Contact your National Oilwell Varco representative.

Versatile Drive and Mounting Options

Unitization services and options compliment the centrifugal pump line. National Oilwell Varco centrifugal pumps are available as horizontal electric, vertical electric, close coupled electric, horizontal diesel, overhead belt, side belt and hydraulic driven pumping units. The horizontal electric units are fabricated on a steel channel base engineered to provide proper alignment with minimal shimming requirements. Diesel driven units are provided with full instrumentation, batteries and fuel tanks. Side overhead belt units feature a small footprint and allow the pump to be operated at the lowest possible speed, which extends pump life significantly. Vertical units require the least amount of deck space. Close coupled horizontal models require the least amount of cubic space and eliminate pump and driver alignment concerns. Hydraulic adapters are available with SAE size "C" and "D" adapters.

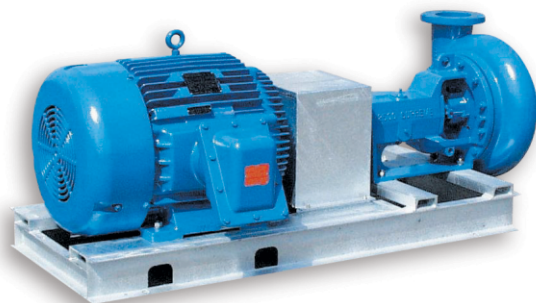
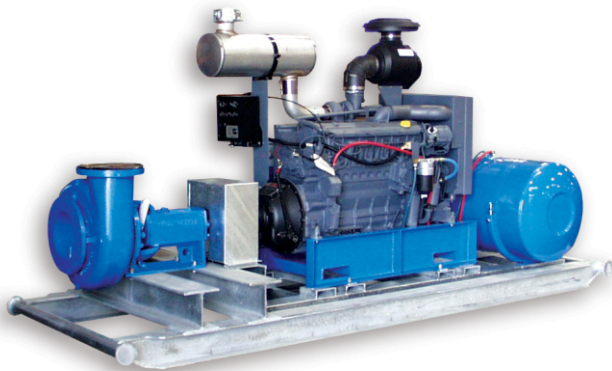

Grease lubricated pumps can be mounted vertically or horizontally and upright or upside down. The casing can be rotated to any angle but the discharge should always be oriented above the suction to prevent air pockets from forming. Custom unitization services are available.

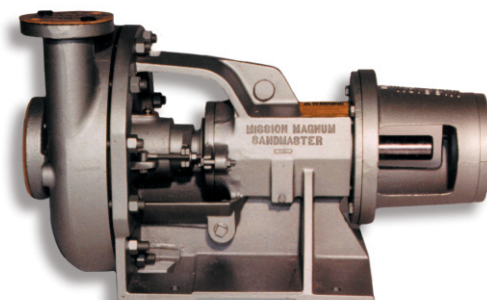
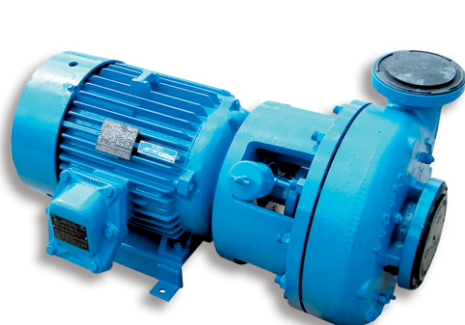

Sandmaster, Vortex and Magnum XP Pumps

SANDMASTER® PUMPS

The compact and adaptable Sandmaster centrifugal pump includes virtually all of the features of the Magnum I. Sandmasters are more compact in design and can be adapted for hydraulic motor drive. These features make Sandmaster pumps ideal for use in applications such as oilfield frac trucks as well as blending and pump charging for water well drilling applications.

All parts for these pumps are identical to the Magnum except for the frame and shaft. The frame and shaft have been shortened 4" to reduce the length of the pump. When space is a premium and prime mover options are limited, the Sandmaster is the pump of choice.

Common applications include:

- Cement
- Charge Pump
- Blender
- Waterwell Drilling
- Other Mobile uses

Available Sizes:

- | | |
|--------|---------|
| 3x2x13 | 6x5x14 |
| 4x3x13 | 8x6x11 |
| 5x4x14 | 8x6x14 |
| 6x5x11 | 10x8x14 |

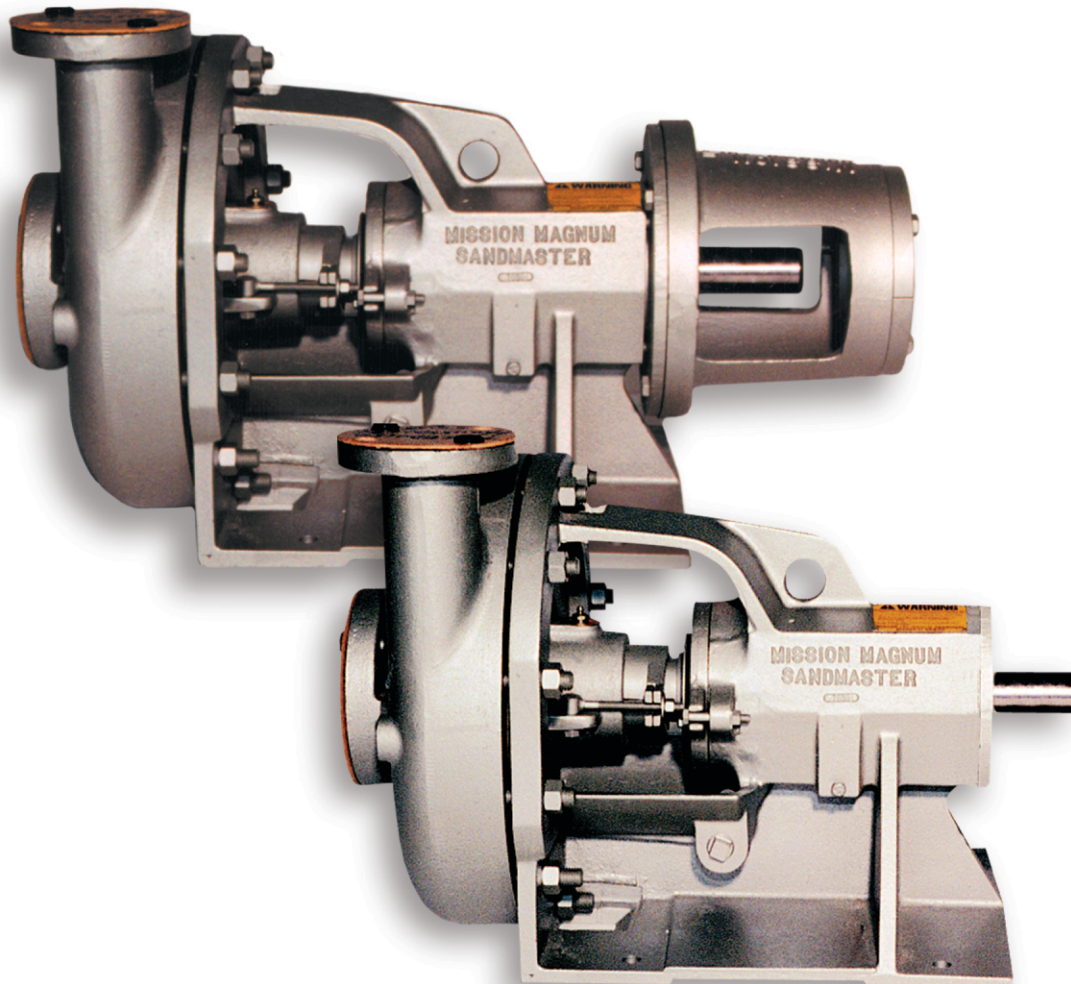

See pages 27-40 for pump performance curves.
See page 47 for dimensional data.

VORTEX PUMPS

The VORTEX centrifugal pump offers proven performance of the MAGNUM I adapted with a concentric vortex casing. The VORTEX also features identically sized suction and discharge flanges, and a high performance vortex designed impeller.

The vortex impeller produces a smooth hydraulic whirlpool of fluid in front of the impeller creating a vacuum. Fluid circulates through the casing with minimal fluid passing through the impeller. This smooth action increases fluid velocity and pressure while minimizing turbulence resulting in reduced particle degradation. Solids smaller than the discharge flow easily, without clogging.

The vortex design eliminates the eye of the impeller reducing the possibility of vapor lock; making it an excellent selection for high suction lift applications where net positive suction head is low. Other benefits of the vortex design include lower radial loads, decreased shaft deflection and increased bearing life. The vortex is designed to pump continuously. Even when the suction runs dry the vortex pump can re-prime without vapor locking and transfer fluid once positive suction feed has been restored.

Common applications include:
Pulp and paper
Primary metals
Municipal sewage treatment
Chemical process industry

Available Sizes:
3x3x14
4x4x14
6x6x14

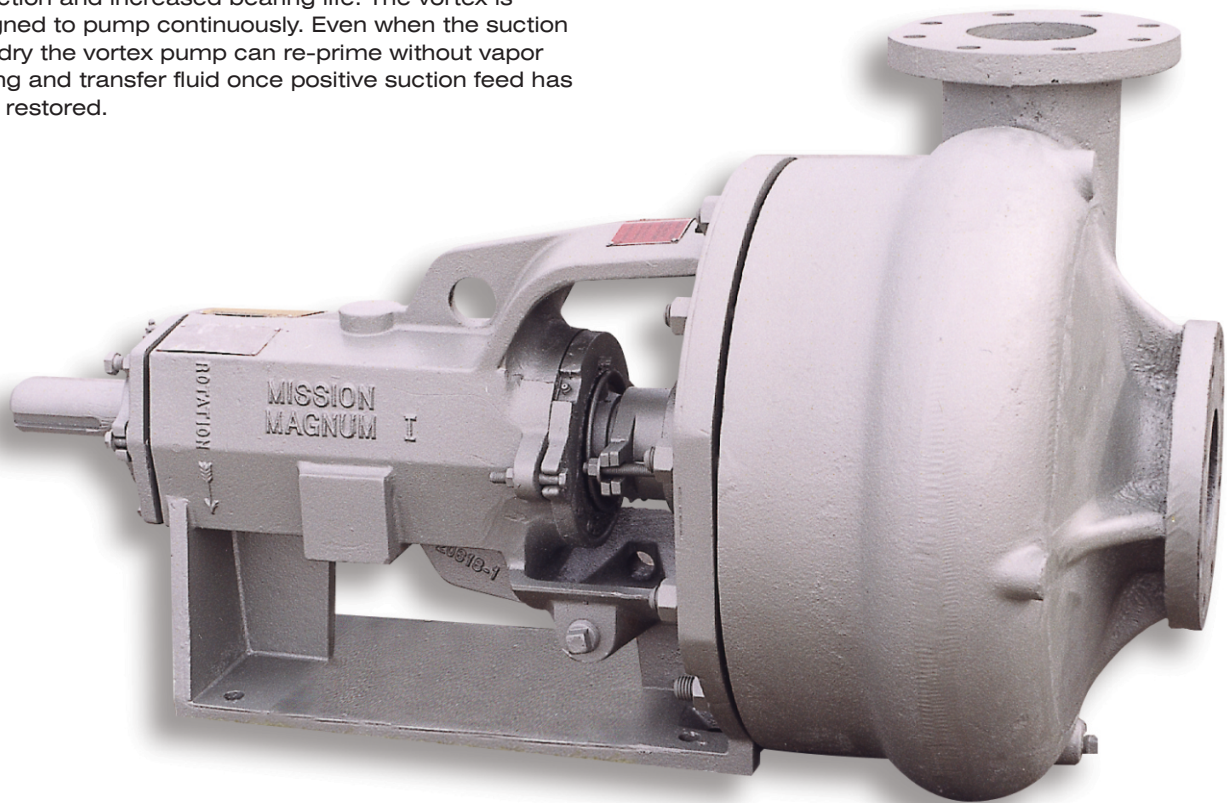

See pages 43-45 for pump performance curves.
See page 48 for dimensional data.

MISSION™ PRODUCTS

MAGNUM XP PUMPS

The MAGNUM XP is ideally suited for pumping high volumes of heavy slurries that are abrasive, corrosive, or just plain tough to pump. The MAGNUM XP 8x6x18, 12x10x23 and 14x12x22 can deliver flow rates up to 7500 GPM and head pressures up to 540 feet.

The compact overall dimensions of the MAGNUM XP make it an excellent choice for high volume mobile and stationary applications where a small footprint is critical.

The MAGNUM XP is designed for continuous operation with minimal maintenance. The low stuffing box pressure and extra-heavy shaft design are engineered to provide maximum seal life. The unique casing flow divider on the 12x10x23 and 14x12x22 cuts the radial load in half, doubling bearing life. The heavy-duty bearings are permanently lubricated to minimize maintenance.

Common applications include:

- Sand slurry
- Supply boat mud transfer
- Slag
- Fly ash
- Bottom ash
- Dredge tailings
- Food processing
- Blending
- Paper pulp processing
- Waste slurries
- Sewage
- Fluid supercharging
- Spent liquor
- Nickel shot
- Copper, bauxite, and quarry slurries
- Lead and zinc ore and tailings

Available Sizes:

- 8X6X18
- 12x10x23
- 14x12x22



See pages 40-42 for pump performance curves.
See page 50 for dimensional data.

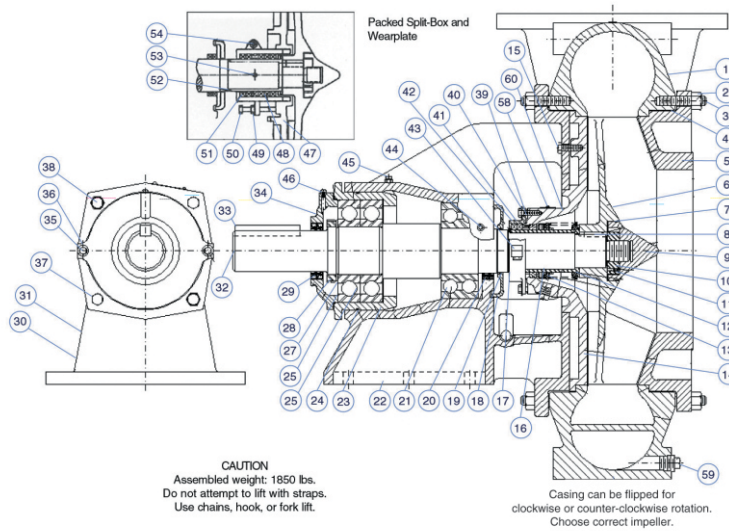

Magnum XP Parts List

Item #	Description	Qty.	Catalog Number	Part Number
1	Casing, 14X12X22	1	24022-01-30A	651120206
	Casing, 12x10x23		25008-01-30A	662001001
	Casing, 8x6x18		25289-02-30A	662002089
2	Nut, Casing	32	3932-61	648402014
	Stud, Casing (14 X 12 and 12 X 10)	32	3862-86	658403308
3	Stud, Casing (8 X 6)	16	3862-90	601208285
	Stud, Casing (8 X 6)	16	3862-92	648401118
	Gasket, Casing (14x12x22)	2	10399-55-01	658410501
4	Gasket, Casing (12x10x23)		25012-01-01	661010001
	Gasket, Casing (8x6x18)		25012-02-05	662010032
	Cover, Front (14x12x22)	1	24021-01-30	654310309
5	Cover, Front (12x10x23)		25009-01-30	662014003
	Cover, Front (8x6x18)		25291-02-30	662014129
	Impeller, 14x12 Clockwise Rot. 22"	1	24024-X0-HS	662005003
6	Impeller, 12x10 Clockwise Rot. 23"		25010-Y0-30	662005002
	Impeller, 8x6 Clockwise Rot. 18"		25292-T0-30	662005018
7	Seal, Impeller Nose	1	7496-158	658408109
8	Key, Impeller	1	4372-29-21	658405006
9	Nose, Impeller (Hex Design)	1	24025-04-25L	652309601
	Nose, Impeller (Two Flat Design)		24025-01-25L	652309600
	Nose, Impeller (2 Flat Ion Nitride)		24025-03-25L	662014054
10	Screw, Set	1	14430-19	658411400
11	Jam Nut	1	24026-25L	658414255
12	Seal, Impeller	1	7496-153	658408059
13	Mechanical Seal (Crane Type)	1	24036	658416102
14	Stuffing Box, Mech. Seal (14 X 12)	1	24027-01-30	653322305
	Stuffing Box, Mech. Seal (12 X 10)		24027-02-30	662014002
	Stuffing Box, Mech. Seal (8 X 6)		25290-02-30	662014128
15	Bolt, Stuffing Box	2	3861-117	648401016
16	Sleeve, Shaft	1	24029-21BZ	656422201
17	Seal, Sleeve	1	7496-234	658408505
18	Slinger	1	24030-01-13	654311604
19	Seal, Slinger	1	7496-238P	658408554
20	Oil Seal, Inboard Bearing	2	20619-03	658413604
21	Bearing, Inboard	1	20615-2	658413000
22	Frame 14 X 12	1	24031-01-01	654312008
	Frame 12 X 10		24031-02-01	662014001
	Frame 8 X 6		25293-02-01	662014130
23	Housing, Bearing	1	24032-01-01	654313006
24	Seal, Bearing Housing	1	7496-272	658408901

Item #	Description	Qty.	Catalog Number	Part Number
25	Bearing, Outboard (14 X 12)	1	20616-2	658413307
	Bearing, Outboard(12 X 10 and 8 X 6)	2	20616-3	661009001
26	Seal, Bearing Cover	1	7496-267	658408802
27	Lock Washer	1	6124-6	658407002
28	Lock Nut, Bearing	1	6123-6	658406509
29	Oil Seal, Bearing Cover	2	20619-04	658413638
30	Drive Screws	6	12530	601482417
31	Nameplate	1	23017	601501505
32	Shaft	1	24028-33	656420007
33	Key, Coupling	1	4372-30-21	658405055
34	Cover, Bearing	1	24033-01-01	654314004
35	Bolts, Bearing Cover	2	3861-139	648401081
36	Washer, Bearing Cover	2	3936-19-L8	648402030
37	Nuts, Bearing Housing	2	3932-62	626402702
38	Bolt, Bearing Housing	4	3861-138	648401057
39	Washer, Flat	2	3936-19-L8	648402030
40	Bolt, Packing Gland	2	3861-165	601408289
41	Gland, Packing Half	2	24034-01-13	654315100
42	Packing Set	1	8264-344-K	658409503
43	Screw, Cap	2	3909-04-87	658404207
44	Plug, Grease	1	8505-1	601474695
45	Breather	1	8267-1	601473689
46	Plug, Fitting	1	19368	661010020
58	Plug, Pipe	2	8505-02-01	658409859
59	Plug, Pipe	1	8505-06-01	658410006
60	Tag, Mechanical Seal	1	22566	603445727

Packed Split-Box and Wearplate

47	Wearplate, Split Box	1	24023-01-XX	654310507
48	Packing Set	1	8264-345-K	658409552
49	Nut and Washer Assembly	2	22216-02	658413935
50	Bolt, Split-Box	2	3861-168	1/2-13x4 lg Gr 5
51	Stuffing Box, Split	2	24037-01-87	654317007
52	Latern Ring Half	2	24039-13	658418207
53	Fitting, Grease	1	19368-01	601499403
54	Screw, Cap	2	3909-13-87	658404405

Auxiliary Tools

55	Tool, Impeller Nose and Nut	1	24040	658420203
	Tool, Impeller Nose (HEX)		Standard Hex Socket	
56	Tool, Impeller Removal	1	24041	658420252
57	Tool, Shaft Holder	1	24042	658420302

Shear Pumps

TurboShear™ System

National Oilwell Varco's TurboShear™ System reduces the cost of mixing polymers and clays while improving mud properties. Shearing the polymers eliminates fish eyes and prevents polymer chaining (long strings), which cannot pass through shaker screens. Pre-hydrating clays improves viscosity per pound of clay, reduces water loss and improves filter cake properties. Additionally, the TurboShear System can be used to dissolve salt and mix oil-base fluids.

Adding clays directly to an active mud system does not result in mud properties equal to those achieved with pre-hydration in a high shear system. When clays are added to the active mud system, high shear cannot be applied to the clays since degradation of drill solids and barite will occur. Clay that has not been properly hydrated when added to an active mud system often continues to hydrate for several days, during which the viscosity level increases. Additional water to reduce viscosity may require disposing of excess mud, which increases costs. Hydrating clays and shearing polymers in a separate compartment, prior to introduction to the active mud system, ensure quality mud properties.

The TurboShear pump is available as a belt-driven or diesel-driven package including a hopper, mud gun and transfer line orifice plate. A complete system, including skid, tanks and piping, is also available

The TurboShear System utilizes the following six methods for shearing:

1. Fluid enters pump through the inlet ports and impacts the shear plate.
2. Fluid passes through the teeth of the shear plate, which is turning at 2200 RPM.
3. Fifty percent of the fluid is re-circulated through the four nozzle scoops and is jetted through 44 nozzles against the shear plate and incoming fluid.
4. Liquid shear occurs at more than 5000 feet per minute. The tip speed of the turbine is more than 7000 feet per minute, causing a liquid shear to occur in addition to the mechanical shear.
5. Shearing occurs as the fluid is jetted into the hydration tank through the mud gun at more than 6000 feet per minute.
6. The product is sheared between the fluid leaving the nozzle and the venturi throat of the hopper.

Available Sizes:

6 x 5
8 x 6

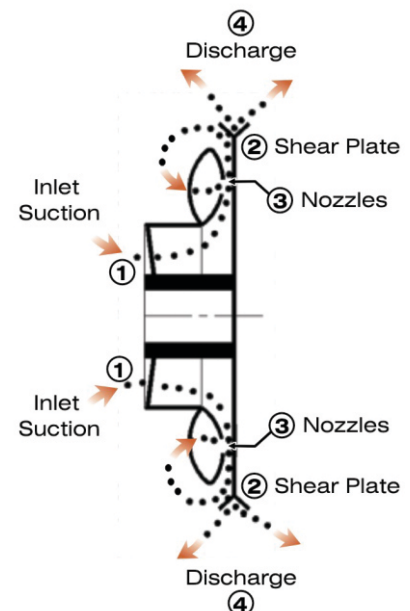
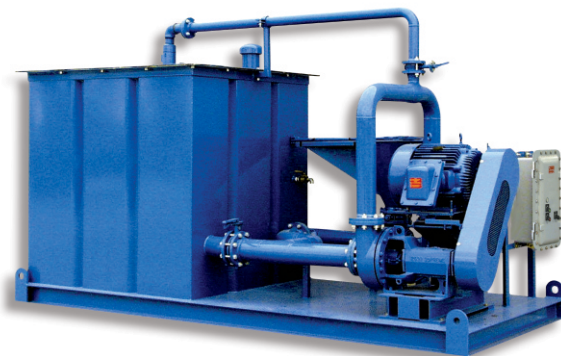
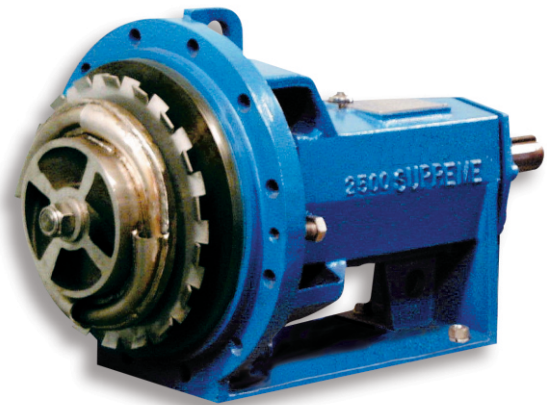
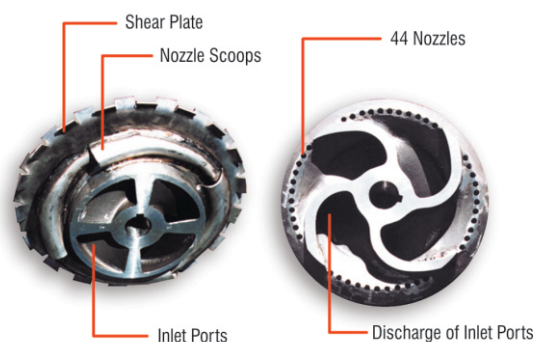

Supreme Shear Pump

The industrial industry discovered that liquid shear occurs between solids when the fluid speed exceeds 5,000 feet per minute. Therefore, an impeller size and speed that produces an impeller tip speed over 5,000 feet per minute causes liquid shear.

When engineering the impeller vane curve, it was designed so a solid particle will move straight out with minimum contact with the impeller (at the pump's best efficiency point). When shearing solids is desired it is beneficial to reverse this engineering practice. Allowing the solids to drag across the impeller vane causes a mechanical shear. To accomplish this, the pump output volume can be restricted to half its best efficiency point. This makes the solids drag on the face of the impeller vane. The Supreme Shear pump features Tungsten Carbide chips adhered to the face of the impeller to give a rough surface that assists in the degradation of solids.

By controlling the impeller size and speed National Oilwell Varco can provide a Supreme Shear pump that incorporates both the liquid and mechanical shear techniques to reduce the size of solids.

The most common use for this application is shearing drill cuttings and injecting them behind the intermediate casing. Testing has shown that the drill cuttings can be reduced to 50 micron by using the Supreme Shear pump. Operating the pump at designed levels and adding solids until the liquid has a range of 11-13 ppg proves to be most effective. Operating less than 11 ppg does not provide enough solids for the liquid shear to occur. Operating greater than 13 ppg results in the material becoming too viscous.

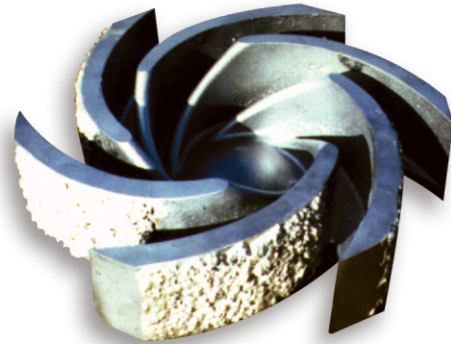

Pump Sizing Information

HOW TO SELECT YOUR PUMP

1. **Before you size the pump, you need to know:**
 - 1.1 **The Pump Speed**
This depends on what kind of drive you put on the pump; 3500, 1750 or 1150 RPM for 60 Hz motors and 3000, 1500 or 1000 RPM for 50 Hz motors. Variable speed curves are provided for diesel, belt drive and hydraulic motors.
 - 1.2 **Total Head Required**
The total head (TH) required is the summation of vertical elevation (He) and friction head (Hf) plus the head required at the end of the piping. $TH = He + Hf + \text{head required at the end of piping}$. Subtract the suction head when the source of supply is above the pump.
To calculate Friction Head loss SEE PAGE 23.
 - 1.3 **Flow Rate**
The flow requirement in GPM or cubic meters per hour.
 - 1.4 The **specific gravity** of the fluid or the weight of the fluid to be pumped such as the mud weight in ppg.
2. **After obtaining the above information.**
 - 2.1 Find the required flow rate on the bottom or top scale and draw a straight line up or down.
 - 2.2 Find the total head at the left or right hand scale and draw a straight line to the right or left.
 - 2.3 Locate the intersection of the above two lines and pick the nearest impeller size. Impellers are available in 1/4" increments. Also a set of horsepower lines gives you the horsepower requirement for pumping water (It is best to choose a motor size larger than the minimum required). If you pump fluid other than water, you have to adjust the required HP (kW) by multiplying the specific gravity to the HP (kW) rating based on water.
3. **NPSH**
Net positive suction head is the useful pressure existing at the suction flange of the pump to push water into the impeller vanes. It is measured in feet (meters) of head. It is called NPSH Available (NPSHa). NPSH Required (NPSHr) is read from the pump curve at the designed pump impeller, RPM, and flow rate. NPSH on the curve is the lowest NPSH that will prevent the formation of vapor bubbles which cause cavitation.
Most customers are not concerned about NPSH problems. However over 50% of all rigs do have NPSH problems. These problems are due in part to high mud temperatures and poor suction design. You should check your net positive suction head (NPSH).

NPSHa Equation - Flooded Suction Systems only:

$$NPSHa = Ha + Hst - Hvp - Hfs$$

NPSHa Equation - Suction Lift Systems only:

$$NPSHa = Ha - Hst - Hvp - Hfs$$

Where:

NPSHa = Net Positive Suction Head Available

NPSHr = Net Positive Suction Head Required

Ha = Absolute Barometric Pressure

Hst = Fluid Supply Level above (Flooded Suction) or below (Suction Lift) Pump Centerline (in feet)

Hvp = Vapor Pressure of the fluid pumped at maximum operating temperature at the pump (in feet)

Hfs = Suction Line Friction Losses (in feet)

The NPSHr as shown on the curves is the minimum NPSH required by the pumps. If the NPSHa is greater than the NPSHr the pump will perform. If the NPSHa is less than NPSHr then the pump will cavitate and some changes to the suction conditions are necessary. Possible solutions are reducing the flow rate, increasing the suction pipe size, selecting a larger pump or lowering the pump speed.

4. Formulas

- 4.1 To Convert Head in Feet to Pressure in Pounds per Square Inch:

$$\frac{\text{Feet of Head} \times \text{Specific Gravity}}{2.31} = \text{PSIG}$$

- 4.2 To convert Pressure in Pounds per Square Inch (PSI) to Head in Feet:

$$\frac{\text{PSIG} \times 2.31}{\text{Specific Gravity}} = \text{Feet of Head}$$

- 4.3 Specific Gravity of Mud = $\frac{\text{Mud Weight (lbs/gal)}}{8.34}$

- 4.4 HP required = Curve HP x specific gravity

5. Pump Sizing Rules

- 5.1 Volume leaving pump increases until the volume pumped causes Total Head losses equal to its impeller output head.
- 5.2 It will help in the selection of impeller size if the friction loss curve is plotted on the pump curve.
- 5.3 Pressure or Head in Feet (meters)
When the pump is running pressure will build up. Pressure developed by the centrifugal pump is always specified as Head in Feet liquid. The relation between PSI and head is shown in 4.1-4.2. When sizing centrifugal pumps it is crucial to work in feet of head rather than PSI. PSI varies with the fluid weight while feet of head is a constant.
- 5.4 Centrifugal Pump Rotation
Stand at the drive end to determine the pump rotation. A right hand rotation pump turns clockwise looking from the motor end. All the pumps featured in this catalog are right hand rotation.

Conversion Factors:

To convert	into	multiply by
m ³ /hr	GPM	4.4
m ³ /min	GPM	264
liters/min	GPM	0.264
liters/sec	GPM	15.9
Barrels/day	GPM	0.02917
cubic feet	Gallons	7.481
kg/cm ²	PSI	14.223
M ³	Gallons	264
meters	Feet	3.28
Bars	PSI	14.7
grams/cu. cm.	SpGr.	1

$$BHP = \frac{\text{GPM} \times \text{Feet} \times \text{Sp.Gr.}}{3960 \times \text{Efficiency}}$$

$$kW = \frac{\text{m}^3/\text{hr} \times \text{meters} \times \text{Sp.Gr.}}{367 \times \text{Efficiency}}$$

Efficiency from curve written as .XX

Affinity Laws

If there is a known operating point and a different operating point is required, the following algebraic formulas can be used to accurately predict what changes should be made to alter the flow or head and what the resulting horsepower requirements will be. A pump's performance can be altered by changing the speed or by changing the impeller diameter. **Note that while the speed formulas are very reliable, the impeller diameter formulas are accurate only for small variations in diameter.**

Speed Formulas or Impeller Diameter Formulas (Valid for small variations in dia. only, max 1")

Flow:

$$\frac{GPM1}{GPM2} = \frac{RPM1}{RPM2} \quad \text{or} \quad \frac{GPM1}{GPM2} = \frac{Dia1}{Dia2}$$

Total Differential Head:

$$\frac{TDH1}{TDH2} = \frac{RPM1^2}{RPM2^2} \quad \text{or} \quad \frac{TDH1}{TDH2} = \frac{Dia1^2}{Dia2^2}$$

Horsepower:

$$\frac{HP1}{HP2} = \frac{RPM1^3}{RPM2^3} \quad \text{or} \quad \frac{HP1}{HP2} = \frac{Dia1^3}{Dia2^3}$$

Example 1:

An 8x6x14 pump with an 11" impeller is operating 1000 GPM at 103 feet and requires 48 HP when pumping water. A contractor wants to be able to increase the discharge pressure to 115 feet. What will be the required impeller diameter, HP, and resulting flow rate?

Answers:

_____ **DIA**
 _____ **GPM**
 _____ **HP Required**

New Imp Dia:

$$\frac{115}{103} = \frac{X^2}{11^2} \quad \text{or} \quad 1.0566 * 11 = X \quad \text{or} \quad 11.62" = X$$

New Flow rate:

$$\frac{X}{1000} = \frac{11.62}{11} \quad \text{or} \quad 1.056 * 1000 = X \quad \text{or} \quad 1056 \text{ GPM} = X$$

HP Required:

$$\frac{X}{48} = \frac{11.62^3}{11^3} \quad \text{or} \quad 48 * 1.177 = X \quad \text{or} \quad 56 \text{ HP} = X$$

Example 2:

If a system exists and a particular operating point and the elevation are known, it is possible to calculate a new operating point by using the following friction loss formulas. Assume a system exists that has 20 feet of elevation and the pump is transferring water 500 GPM and the pressure gauge reads 50 PSI at the pump discharge. What pressure head is required to produce 1000 GPM?

First convert PSI to feet:

$$\text{Pressure Head} = 50 \text{ PSI} * 2.31 / 1.0 \text{ Sp.Gr.}$$

$$\text{Pressure Head} = 115 \text{ Feet}$$

Subtract lift of 20 feet since this is a constant:

$$115 \text{ feet pressure head} - 20 \text{ feet elevation} = 95 \text{ feet of system friction loss at 500 GPM}$$

Use the following formula to determine the new pressure head required to produce 1000 GPM in this system:

$$\frac{\text{Friction loss 1}}{\text{Friction loss 2}} = \frac{GPM1^2}{GPM2^2} \quad \text{or} \quad \frac{X}{95} = \frac{1000^2}{500^2}$$

$$\text{or } X = 95 (1000/500)^2 = 380 \text{ Feet}$$

Add back the lift:

$$380 + 20 = 400$$

It would therefore be necessary to size a pump for 1000 GPM at 400 feet to obtain the desired flow rate of 1000 GPM in the existing system.

SYSTEM HEAD REQUIREMENT WORK SHEET

CONDITIONS

Liquid Pumped _____ Flow Rate (GPM) _____

Calculated Feet of Head _____ (line "6") Specific Gravity _____ Temperature _____ °F

1. Suction: Pipe Size _____ inches.

(1a) Vertical Distance (liquid surface to pump center line +/-). Positive number if above pump center line or negative number if below pump center line _____ feet.

(1b) Total length of suction line _____ feet.

(1c) Straight pipe equivalent of suction fittings:

Type	Qty.		Equiv. Ft. per Fitting (Ref. Table on page 25)	=	Total Equiv. Ft. of Straight Pipe
Elbow	_____	x	_____	=	_____
Tee Running	_____	x	_____	=	_____
Tee Branched	_____	x	_____	=	_____
Swing Check	_____	x	_____	=	_____
Globe Valve	_____	x	_____	=	_____
Butterfly Valve	_____	x	_____	=	_____

(1c) Sum Total = _____

(1d) Add (1b) and (1c) = _____ equivalent feet of straight suction pipe.

(1e) Convert to friction loss head: $\frac{(1d)}{100} \times \text{Head Loss (Ref. Table on page 24)} = \text{___ feet of head (friction loss)}$

2. Discharge: Pipe Size _____ inches.

(2a) Vertical Distance (centerline of pump to highest point in discharge system +/-) _____ feet.

(2b) Total length of discharge line _____ feet.

(2c) Straight pipe equivalent of discharge fittings:

Type	Qty.		Equiv. Ft. per Fitting (Ref. Table on page 25)	=	Total Equiv. Ft. of Straight Pipe
Elbow	_____	x	_____	=	_____
Tee Running	_____	x	_____	=	_____
Tee Branched	_____	x	_____	=	_____
Swing Check	_____	x	_____	=	_____
Globe Valve	_____	x	_____	=	_____
Butterfly Valve	_____	x	_____	=	_____

(2c) Sum Total = _____

(2d) Add (2b) and (2c) = _____ equivalent feet of straight suction pipe.

(2e) Convert to friction loss head: $\frac{(2d)}{100} \times \text{Head Loss (Ref. Table on page 24)} = \text{___ feet of head (friction loss)}$

3. Pressure required at discharge point _____ psig x 2.31 = _____ feet of head.
Sp.Gr.

4. Total Friction Head (Hf) = (1e) + (2e) _____

5. Total Elevation Head (He) = (2a) - (1a) _____

6. Total Head Required at Pump Discharge = Hf + He + line "3" = _____ feet of head required.¹

¹ NOTE: NPSHa must also be considered. See previous pages for NPSHa calculation method.

Friction of Water in Pipes C=100

GPM	2" PIPE		3" PIPE		4" PIPE		5" PIPE		6" PIPE		8" PIPE		GPM
	V	F	V	F	V	F	V	F	V	F	V	F	
30	3.06	3.69	1.36	0.53	0.77	0.13							30
40	4.08	6.40	1.81	0.91	1.02	0.22							40
50	5.11	9.90	2.27	1.38	1.28	0.34	0.82	0.11					50
60	6.13	13.40	2.72	1.92	1.53	0.48	0.98	0.16					60
70	7.15	17.04	3.18	2.56	1.79	0.63	1.14	0.21	0.79	0.09			70
80	8.17	22.50	3.63	3.28	2.04	0.81	1.31	0.27	0.91	0.11			80
90	9.19	28.00	4.08	4.08	2.30	1.01	1.47	0.34	1.02	0.14			90
100	10.21	35.80	4.54	4.96	2.55	1.22	1.63	0.41	1.14	0.17			100
125	12.76	50.90	5.68	7.50	3.19	1.85	2.04	0.62	1.42	0.26			125
150	15.32	76.00	6.81	10.50	3.83	2.59	2.47	0.87	1.70	0.36	0.96	0.09	150
175	17.86	92.50	7.95	14.00	4.47	3.44	2.86	1.16	1.99	0.48	1.12	0.12	175
200	20.40	129.00	9.08	17.90	5.10	4.41	3.27	1.49	2.27	0.61	1.28	0.15	200
225			10.20	22.30	5.74	5.48	3.68	1.85	2.55	0.76	1.44	0.19	225
250			11.30	27.10	6.38	6.67	4.08	2.25	2.84	0.93	1.60	0.23	250
275			12.50	32.30	7.02	7.96	4.50	2.68	3.12	1.11	1.76	0.27	275
300			13.60	37.90	7.65	9.34	4.90	3.13	3.41	1.30	1.91	0.32	300
350			15.90	50.40	8.93	12.40	5.72	4.20	3.97	1.73	2.23	0.43	350
400			18.20	64.60	10.20	15.90	6.54	5.38	4.54	2.21	2.55	0.55	400
450					11.50	19.80	7.36	6.68	5.10	2.75	2.87	0.68	450
500					12.80	24.10	8.18	8.12	5.68	3.34	3.19	0.82	500
550					14.00	28.70	8.99	9.69	6.24	3.99	3.51	0.98	550
600					15.30	33.70	9.81	11.40	6.81	4.68	3.82	1.15	600
650					16.60	39.10	10.60	13.20	7.38	5.43	4.15	1.34	650
700					17.90	44.90	11.40	15.10	7.94	6.23	4.47	1.53	700
750					18.90	51.30	12.30	17.20	8.51	7.08	4.78	1.74	750
800							13.10	19.40	9.08	7.98	5.10	1.97	800
900							14.70	24.10	10.20	9.92	5.74	2.44	900
1000							16.30	29.30	11.40	12.10	6.38	2.97	1000
1100							18.00	35.00	12.50	14.40	7.02	3.55	1100
1200							19.56	41.20	13.60	16.90	7.66	4.17	1200
1300							21.19	48.00	14.80	19.60	8.30	4.83	1300
1400							22.82	54.80	15.90	22.50	8.93	5.54	1400
1500							24.45	62.40	17.00	25.50	9.55	6.30	1500
1600									18.20	28.80	10.20	7.10	1600
1800									20.52	35.90	11.50	9.83	1800
2000									22.80	43.60	12.80	10.70	2000

V = Velocity feet per second

F = Friction head in feet

Loss of head in feet, due to friction, per 100 feet of ordinary pipe and velocity in feet per second.

Values taken from Williams and Hazen tables, based on coefficient C = 100. For new pipes multiply friction loss value by 0.70.

Values of C for various types of pipe are given below together with the corresponding multiplier which should apply to the tabulated values of the head loss, hf.

MISSION™ PRODUCTS

Values of C

TYPE OF PIPE	RANGE: High = best, smooth, well laid Low = poor or corroded	Average value for good, clean new pipe	Commonly used value for design purposes
Cement - asbestos	160-140	150	140
Fibre	-	150	140
Bitumastic-enamel-lined iron or steel centrifugally applied	160-130	148	140
Cement lined iron or steel centrifugally applied	-	150	140
Copper, brass, lead, tin or glass pipe and tubing	150-120	140	130
Wood-stave	140-110	120	110
Welded and seamless steel	150-80	140	100
Continuous-interior riveted steel (no projecting rivets or joints)	-	139	100
Wrought iron	150-80	130	100
Cast-iron	150-80	130	100
Tar-coated cast iron	145-80	130	100
Girth-riveted steel (projecting rivets in girth seams only)	-	130	100
Concrete	152-85	120	100
Full-riveted steel (projecting rivets in girth and horizontal seams)	-	115	100
Vitrified	-	110	100
Spiral-riveted steel (flow with lap)	-	110	100
Spiral-riveted steel (flow against lap)	-	100	90
Corrugated steel	-	60	60

Table Correction Multipliers

Value of C...	130	120	110	100	90	80	70	80	70	60
Multiplier to correct tables	0.63	0.71	0.84	1.00	1.22	1.58	1.93	1.58	1.93	2.57

Friction Loss in Pipe Fittings in Terms of Equivalent Feet of Straight Pipe

Nominal Pipe Size	Actual Inside Diameter	Gate valve		Long radius		Std. tee		Swing check valve		Angle valve		Globe valve	
		---	90°	90° or 45° std. elbow	---	---	Close retun bend	---	---	---	Butterfly valve		
1-1/2	1.61	1.07	4.03	2.15	2.68	8.05	6.71	13.4	20.1	45.6			
2	2.067	1.38	5.17	2.76	3.45	10.3	8.61	17.2	25.8	58.6	7.75		
2-1/2	2.469	1.65	6.17	3.29	4.12	12.3	10.3	20.6	30.9	70.0	9.26		
3	3.068	2.04	7.67	4.09	5.11	15.3	12.8	25.5	38.4	86.9	11.5		
4	4.026	2.68	10.1	5.37	6.71	20.1	16.8	33.6	50.3	114.0	15.1		
5	5.047	3.36	12.6	6.73	8.41	25.2	21	42.1	63.1	143	18.9		
6	6.065	4.04	15.2	8.09	10.1	30.3	25.3	50.5	75.8	172	22.7		
8	7.981	5.32	20	10.6	13.3	39.9	33.3	58	99.8	226	29.9		
10	10.02	6.68	25.1	13.4	16.7	50.1	41.8	65	125	284	29.2		
12	11.938	7.96	29.8	15.9	19.9	59.7	49.7	72	149	338	34.8		
14	13.124	8.75	32.8	17.5	21.8	65.6	54.7	90	164	372	38.3		
16	15	10	37.5	20	25	75	62.5	101	188	425	31.3		
18	16.876	16.9	42.2	22.5	28.1	84.4	70.3	120	210	478	35.2		
20	18.814	12.5	47	25.1	31.4	94.1	78.4	132	235	533	39.2		

Calculated from data in Crane Co. - Technical Paper 410

Properties of Water

Temperature °F	Temperature °C	Specific Gravity	Vapor Pressure of water, absolute (feet)
40	4.4	1.001	0.30
50	10	1.001	0.40
60	15.6	1.000	0.60
70	21.1	0.999	0.80
80	26.7	0.998	1.20
90	32.2	0.996	1.60
100	37.8	0.994	2.20
110	43.3	0.992	3.00
120	48.9	0.990	4.00
130	54.4	0.987	5.20
140	60	0.985	6.80
150	65.6	0.982	8.80
160	71.1	0.979	11.20
170	76.7	0.975	14.20
180	82.2	0.972	17.90

Theoretical Discharge of Nozzles in U.S. Gallons Per Minute

Head psi	Velocity of Discharge		Diameter of nozzle (inches)																	
	feet*	(ft/sec)	3/8	1/2	5/8	3/4	7/8	1	1-1/8	1-1/4	1-3/8	1-1/2	1-3/4	2	2-1/4	2-1/2	2-3/4	3	3-1/2	4
10	23.1	38.6	13.3	23.6	36.9	53.1	72.4	94.5	120	148	179	213	289	378	479	591	714	851	1158	1510
15	34.6	47.25	16.3	28.9	45.2	65.0	88.5	116.0	147	181	219	260	354	463	585	723	874	1041	1418	1850
20	46.2	54.55	18.8	33.4	52.2	75.1	102.0	134.0	169	209	253	301	409	535	676	835	1009	1203	1638	2135
25	57.7	61.00	21.0	37.3	58.3	84.0	114.0	149.0	189	234	283	336	458	598	756	934	1128	1345	1830	2385
30	69.3	66.85	23.0	40.9	63.9	92.0	125.0	164.0	207	256	309	368	501	655	828	1023	1236	1473	2005	2615
35	80.8	72.20	24.8	44.2	69.0	99.5	135.0	177.0	224	277	334	398	541	708	895	1106	1335	1591	2168	2825
40	92.4	77.20	26.6	47.3	73.8	106.0	145.0	188.0	239	296	357	425	578	756	957	1182	1428	1701	2315	3020
45	103.9	81.80	28.2	50.1	78.2	113.0	153.0	200.0	253	313	379	451	613	801	1015	1252	1512	1802	2455	3200
50	115.5	86.25	29.7	52.8	82.5	119.0	162.0	211.0	267	330	399	475	647	845	1070	1320	1595	1900	2590	3375
55	127.0	90.50	31.1	55.3	86.4	125.0	169.0	221.0	280	346	418	498	678	886	1121	1385	1671	1991	2710	3540
60	138.6	94.50	32.5	57.8	90.4	130.0	177.0	231.0	293	362	438	521	708	926	1172	1447	1748	2085	2835	3700
65	150.1	98.30	33.8	60.2	94.0	136.0	187.0	241.0	305	376	455	542	737	964	1220	1506	1819	2165	2950	3850
70	161.7	102.10	35.2	62.5	97.7	141.0	191.0	250.0	317	391	473	563	765	1001	1267	1565	1888	2250	3065	4000
75	173.2	105.70	36.4	64.7	101.0	146.0	198.0	259.0	327	404	489	582	792	1037	1310	1619	1955	2330	3170	4135
80	184.8	109.10	37.6	66.8	104.0	150.0	205.0	267.0	338	418	505	602	818	1070	1354	1672	2020	2405	3280	4270
85	196.3	112.50	38.8	68.9	108.0	155.0	211.0	276.0	349	431	521	620	844	1103	1395	1723	2080	2480	3375	4400
90	207.9	115.80	39.9	70.8	111.0	160.0	217.0	284.0	359	443	536	638	868	1136	1436	1773	2140	2550	3475	4530
95	219.4	119.00	41.0	72.8	114.0	164.0	223.0	292.0	369	456	551	656	892	1168	1476	1824	2200	2625	3570	4655
100	230.9	122.00	42.1	74.7	117.0	168.0	229.0	299.0	378	467	565	672	915	1196	1512	1870	2255	2690	3660	4775

The actual quantity discharged by a nozzle will be less than the above table. A well tapered smooth nozzle may be assumed to flow 97 to 99% of the values in the tables. Mud gun nozzles will flow approximately 85% of the above table and hopper nozzles will flow approximately 75% of the above table.

* Head in feet basis water at approximately 60°F

Pump Performance Curves

UNDERSTANDING PUMP PERFORMANCE CURVES

The head vs. flow curves on the following pages give you the performance of the Magnum, 2500 Supreme, Magnum Vertical, 2500 Vertical and Sandmaster pumps at various speeds and with various impeller sizes. The horsepower (HP) rating is based on pumping water with a specific gravity of 1.0. The flow is measured in US liquid gallons per minute (GPM). The total differential head is measured in feet. There are also a series of Efficiency and Net Positive Suction Head Required (NPSHr) lines showing the pump hydraulic efficiency and minimum NPSHr. The performance curves are plotted based on actual test results for each size of pumps running at various RPM and with various impeller sizes.

To determine the HP required for your system you will need to determine the Specific Gravity (Sp.Gr.) of the fluid being transferred and then multiply the Sp.Gr. by the HP shown on the curve. To determine Sp.Gr.:

$$\text{Specific Gravity} = \frac{\text{ppg of fluid}}{8.34}$$

Magnum I

3X2X13

Speed: 1150 RPM

Curve: 944

Open Impeller

Dia: 7" to 13"

Eye Area: 7.1 Sq. In.

Max Sphere: ½ In.

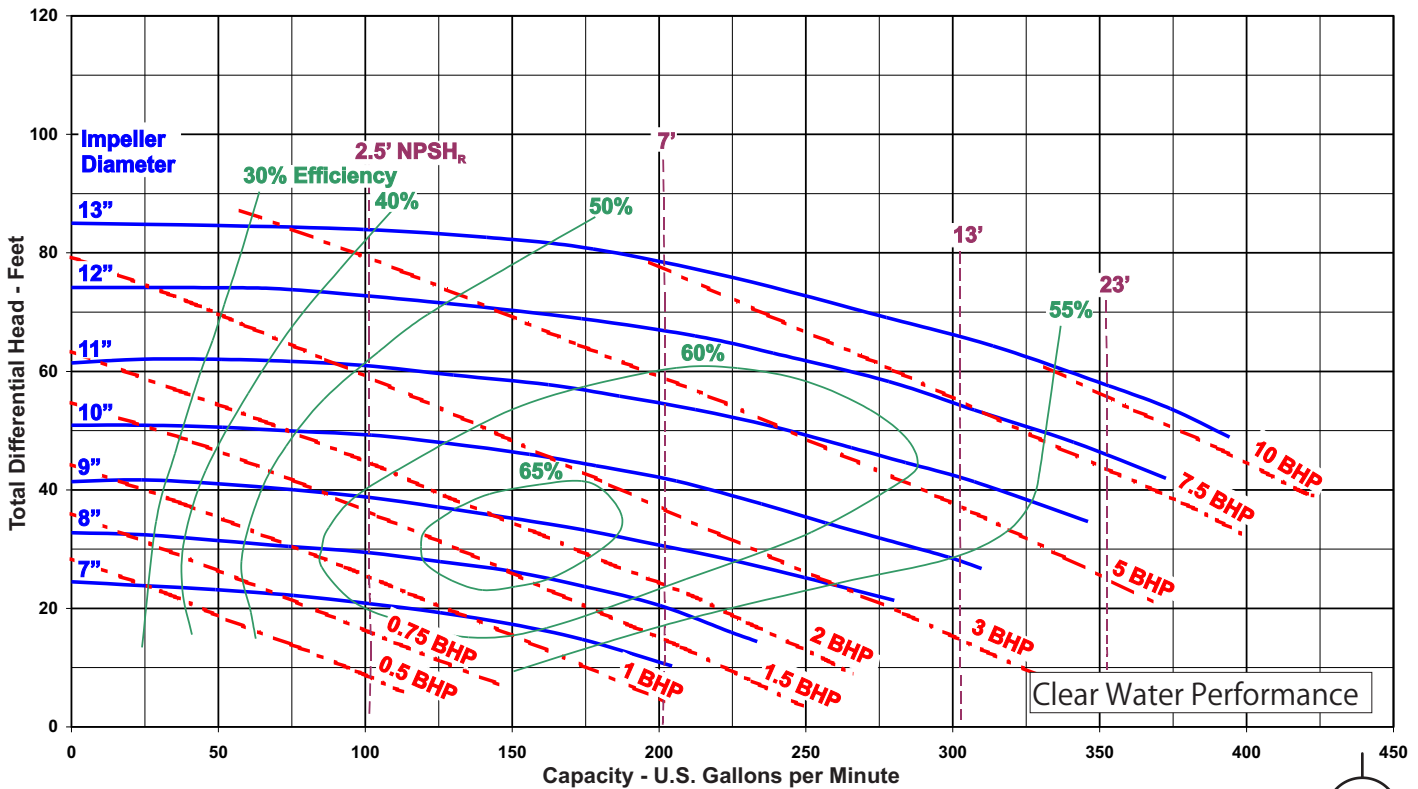

Magnum I
 3X2X13
 Speed: 1750 RPM
 Curve: 945

Open Impeller
 Dia: 6" to 13"
 Eye Area: 7.1 Sq. In.
 Max Sphere: 1/2 In.

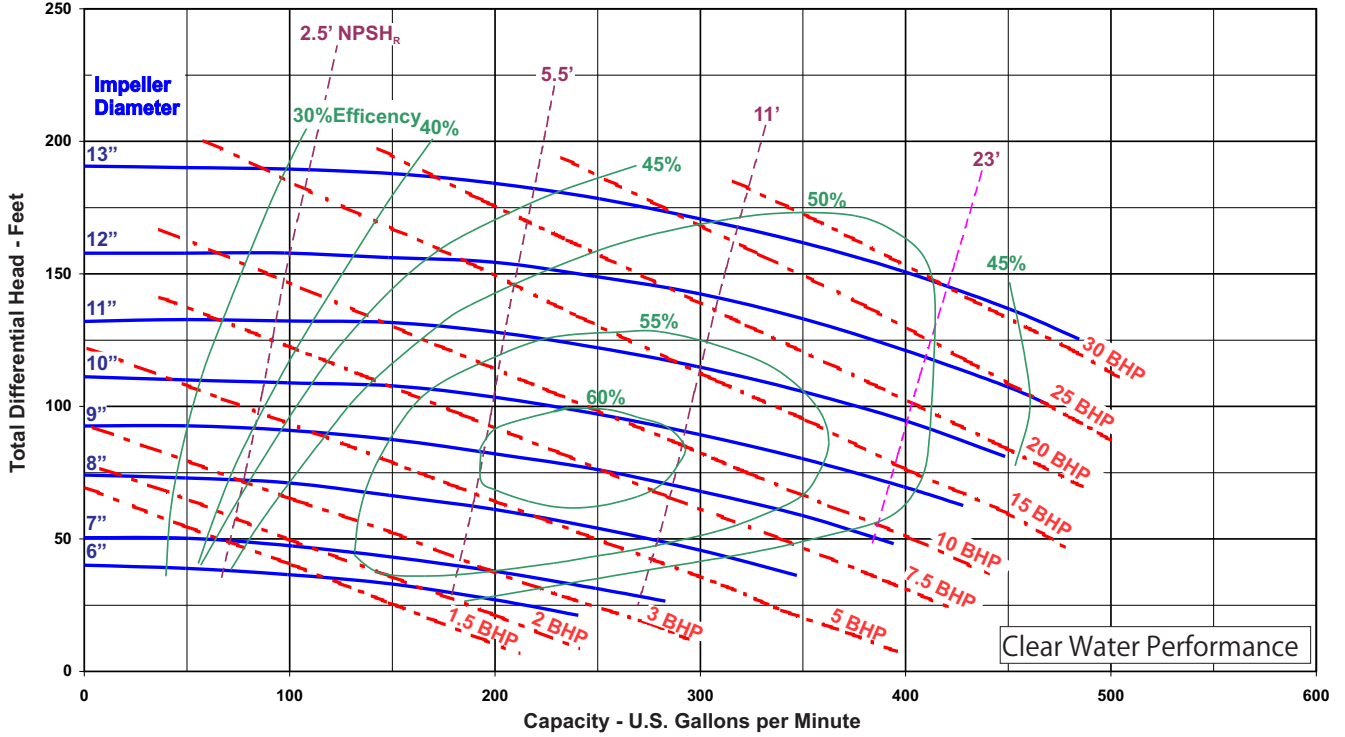

Magnum I
 3X2X13
 Speed: 3500 RPM
 Curve: 946

Open Impeller
 Dia: 6" to 11"
 Eye Area: 7.1 Sq. In.
 Max Sphere: 1/2 In.

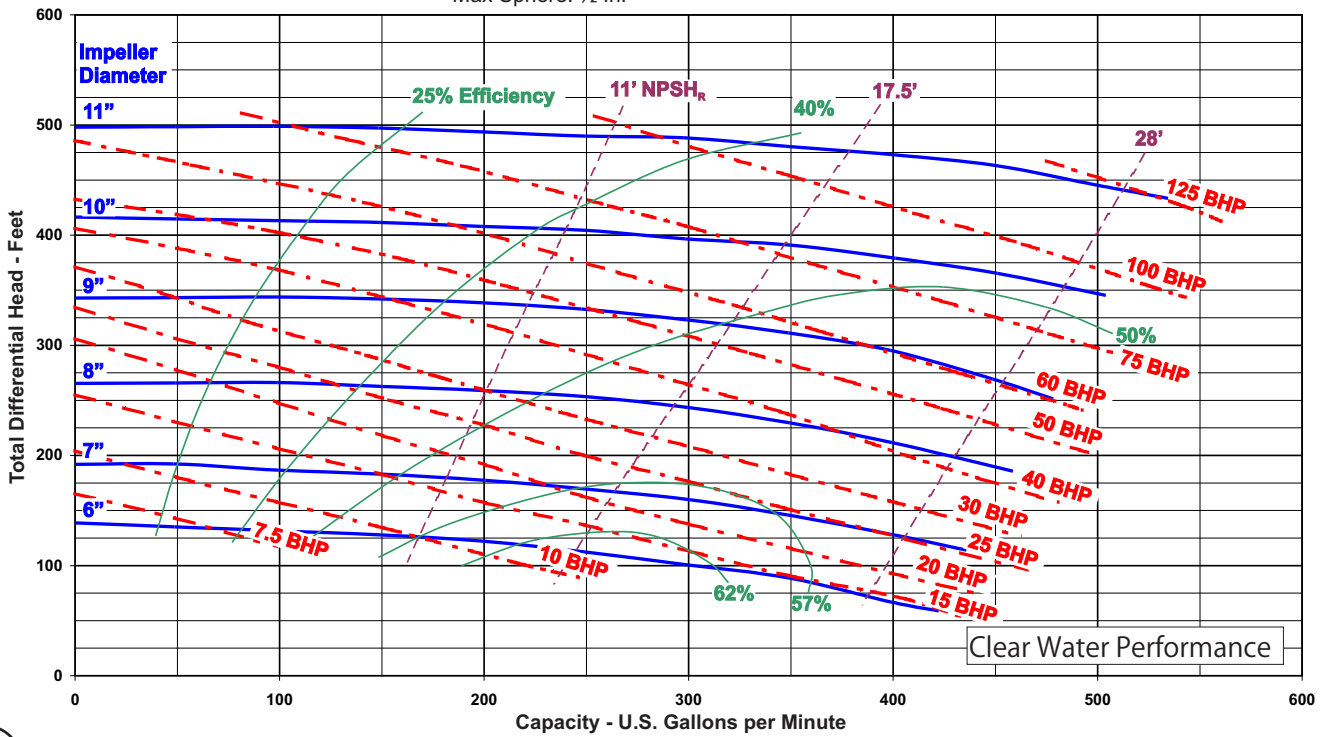

MISSION™ PRODUCTS

Magnum I
 3X2X13
 Speed: 700-2500 RPM
 Curve: 976

Open Impeller
 Dia: 13"
 Eye Area: 7.1 Sq. In.
 Max Sphere: ½ In.

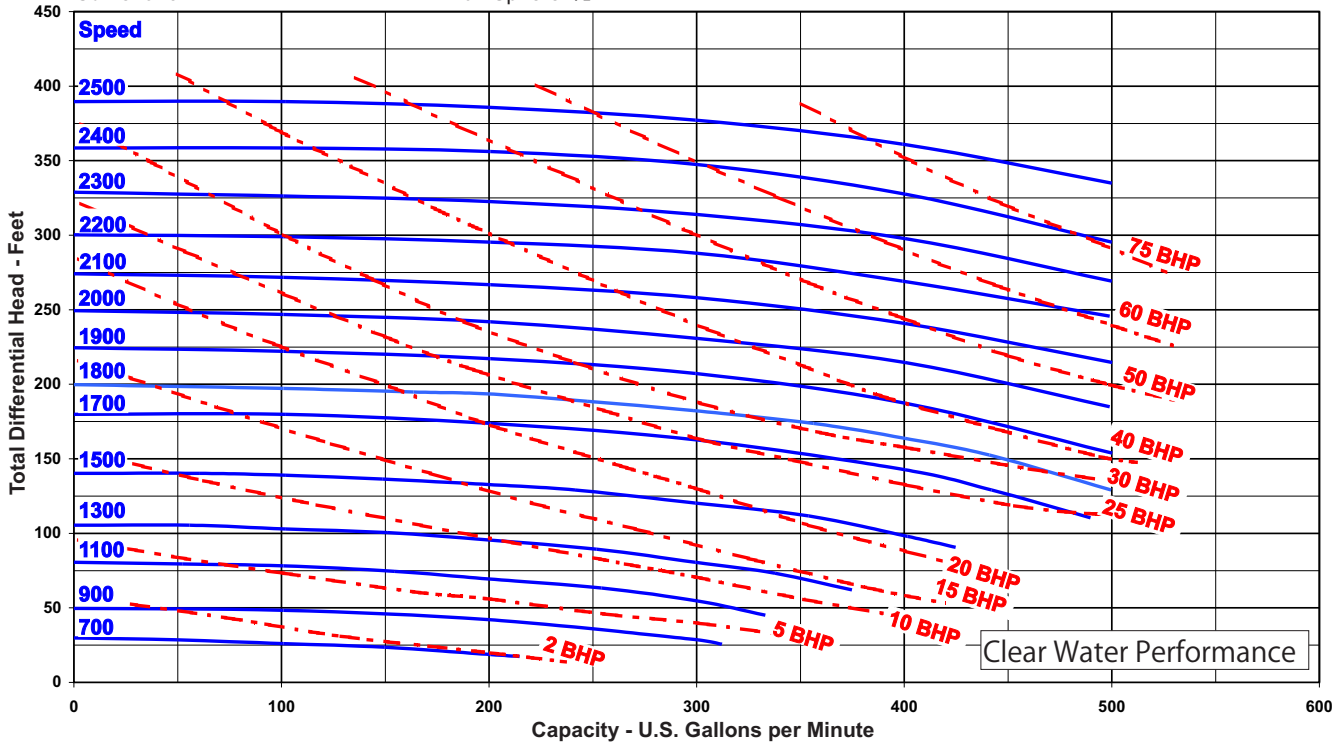

Magnum I
 4X3X13
 Speed: 1150 RPM
 Curve: 947

Open Impeller
 Dia: 7" to 13"
 Eye Area: 12.5 Sq. In.
 Max Sphere: ¾ In.

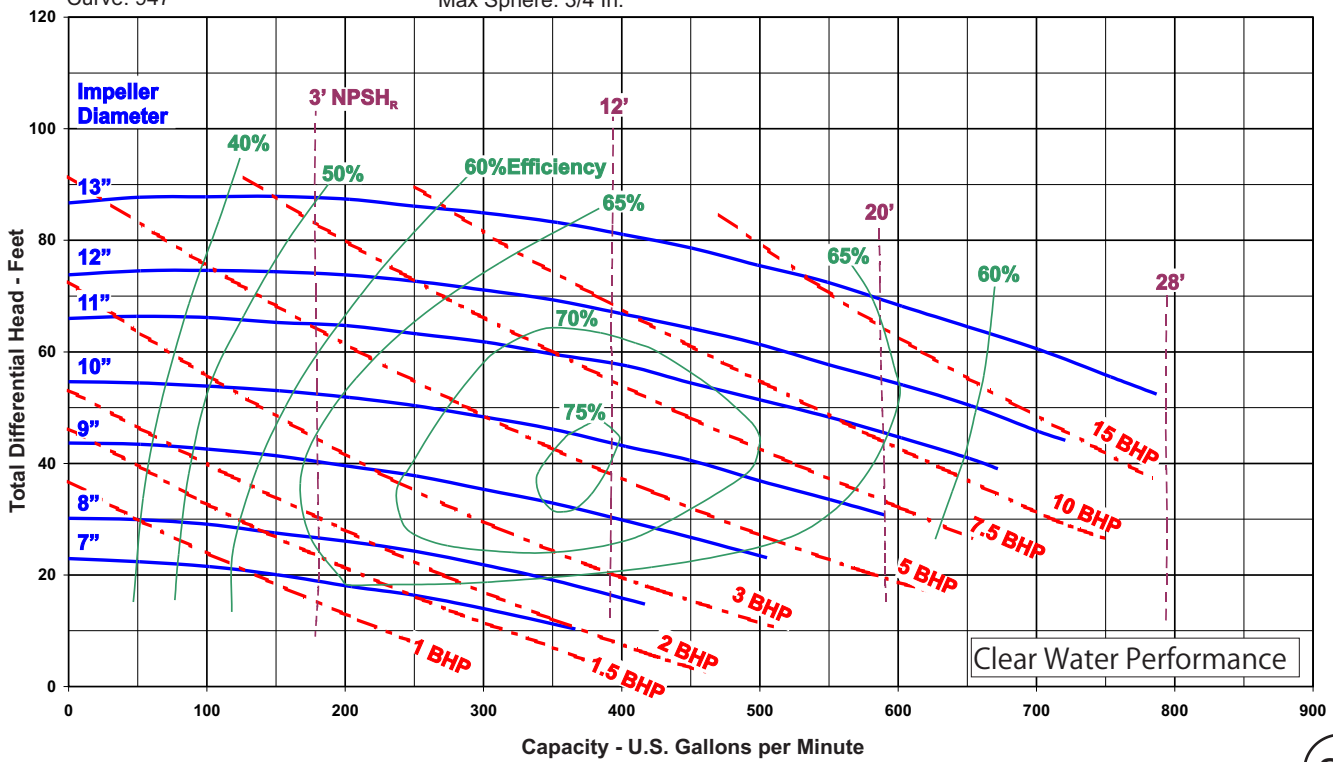

Magnum I
4X3X13
Speed: 1750 RPM
Curve: 948

Open Impeller
Dia: 7" to 13"
Eye Area: 12.5 Sq. In.
Max Sphere: 3/4 In.

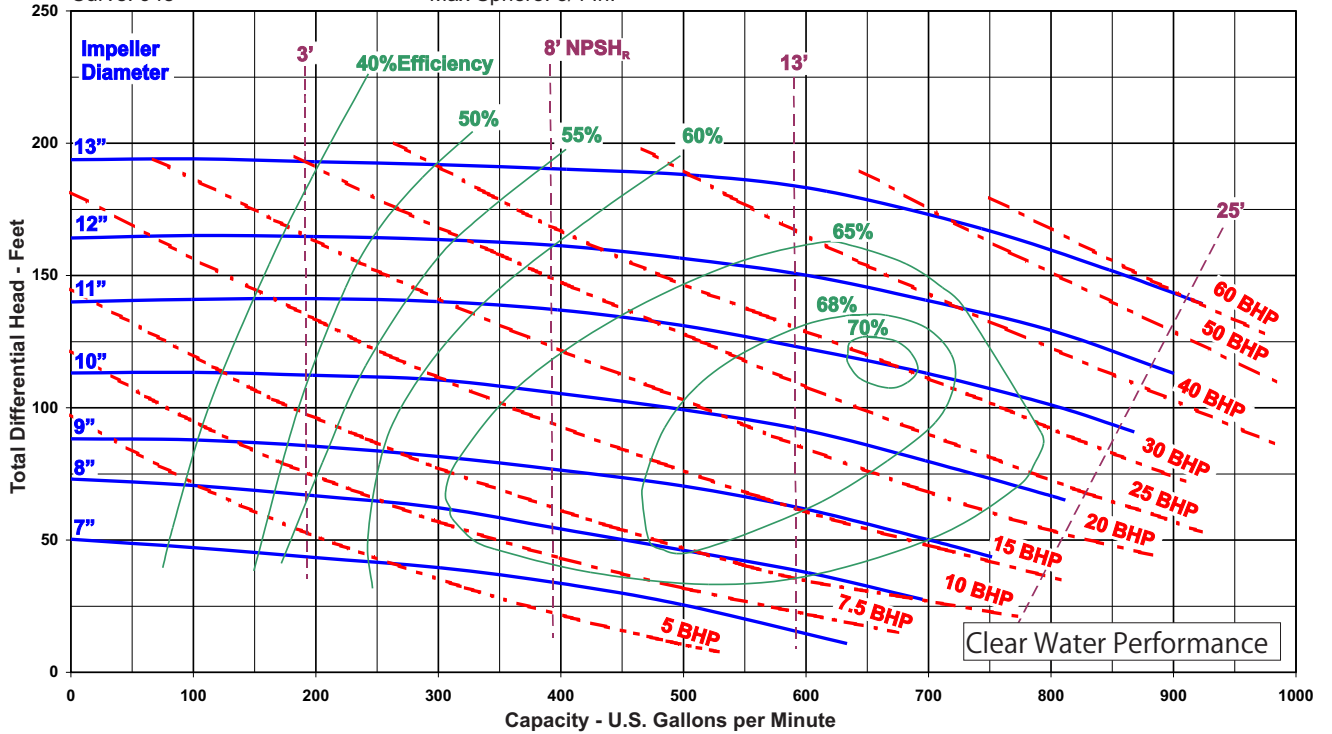

Magnum I
4X3X13
Speed: 3500 RPM
Curve: 949

Open Impeller
Dia: 6" to 11"
Eye Area: 12.5 Sq. In.
Max Sphere: 3/4 In.

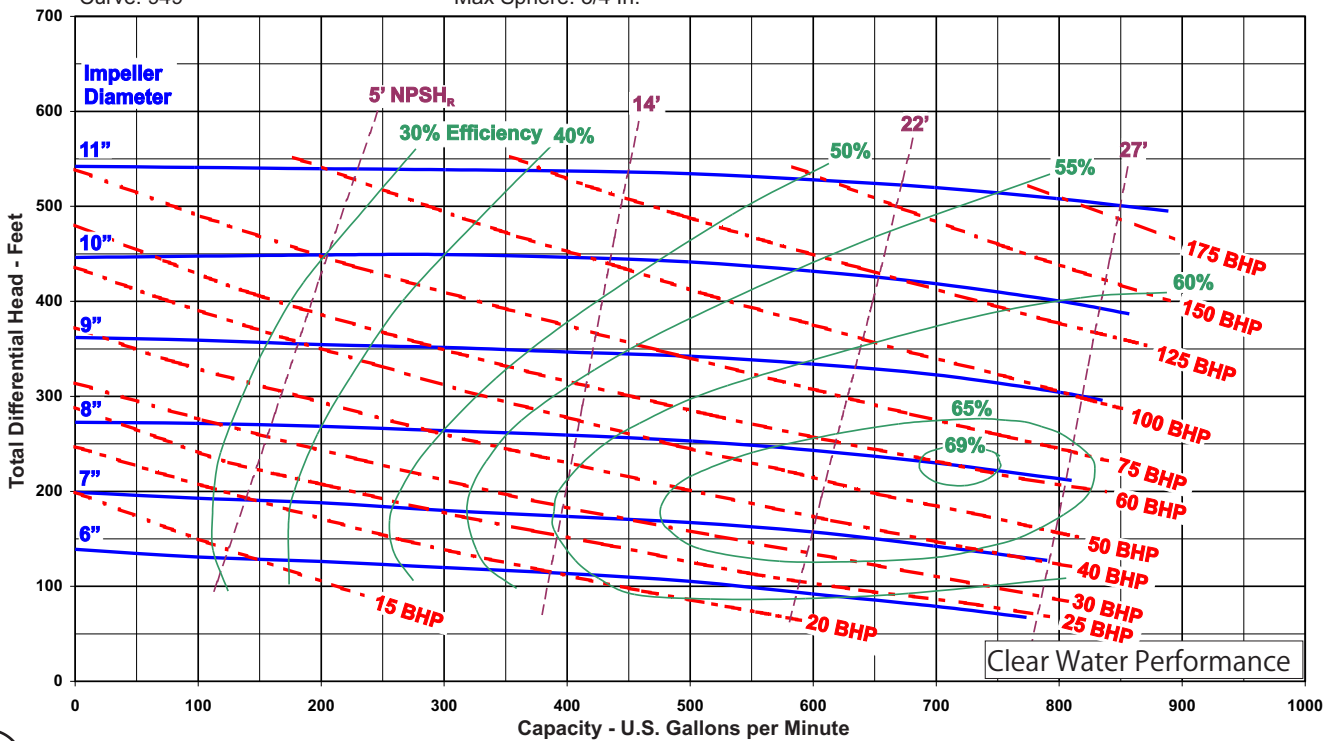

MISSION™ PRODUCTS

Magnum I
 4X3X13
 Speed: 1000-2400 RPM
 Curve: 977

Open Impeller
 Dia: 13"
 Eye Area: 12.5 Sq. In.
 Max Sphere: 3/4 In.

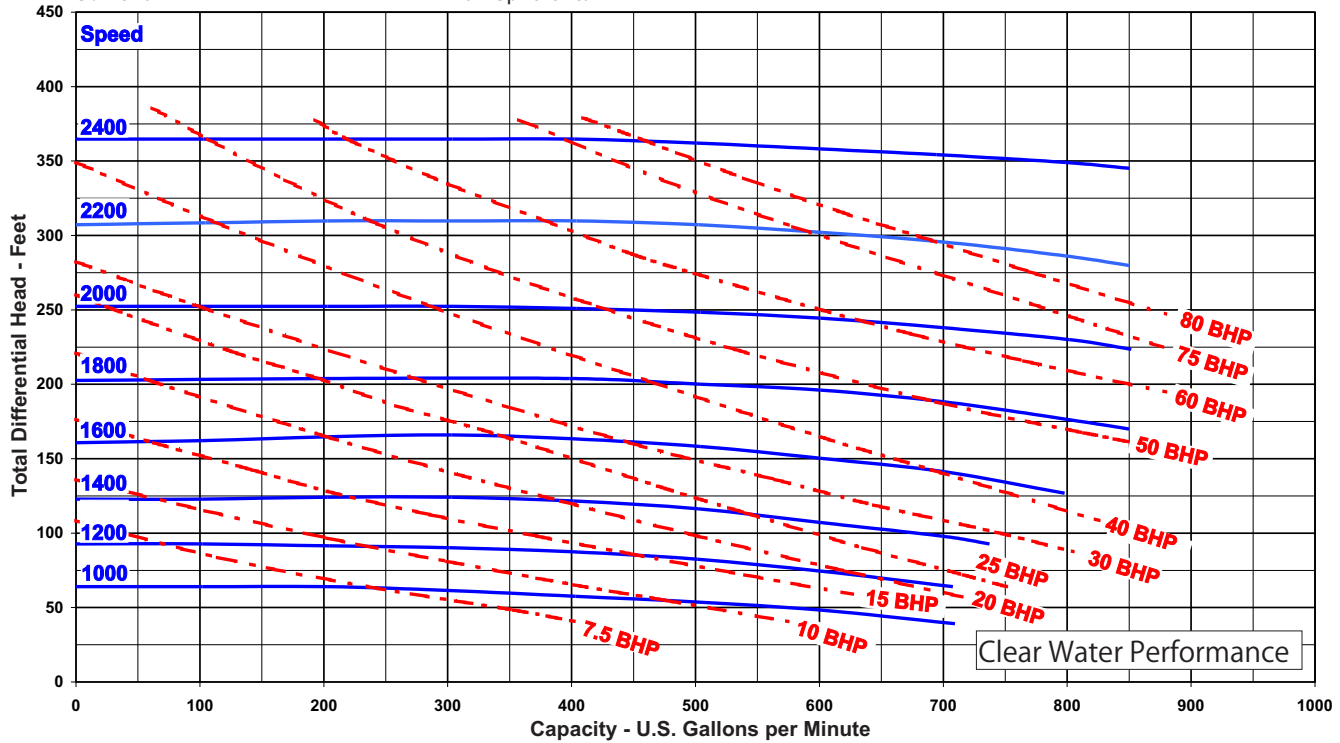

Magnum I
 5X4X14
 Speed: 1150 RPM
 Curve: 950

Open Impeller
 Dia: 7" to 14"
 Eye Area: 19.6 Sq. In.
 Max Sphere: 13/32 In.

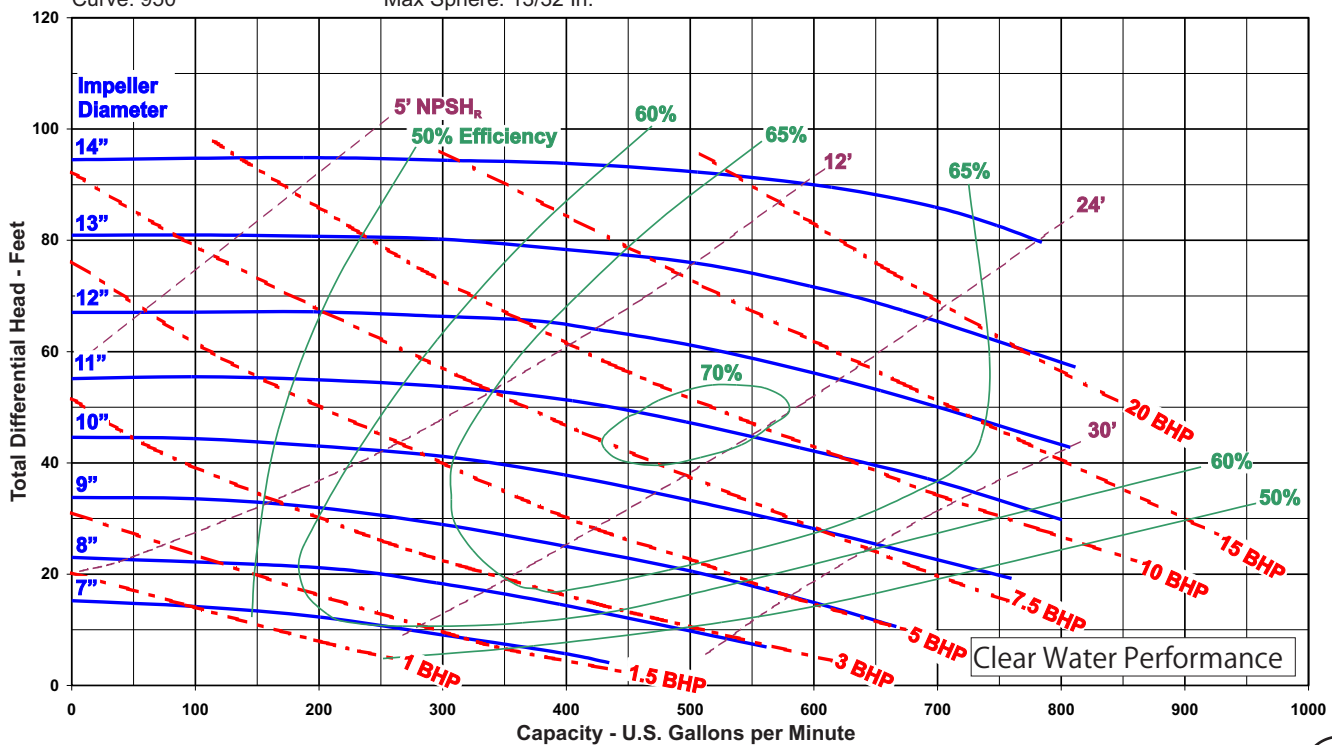

Magnum I
 5X4X14
 Speed: 1750 RPM
 Curve: 951

Open Impeller
 Dia: 7" to 14"
 Eye Area: 19.6 Sq. In.
 Max Sphere: 13/32 In.

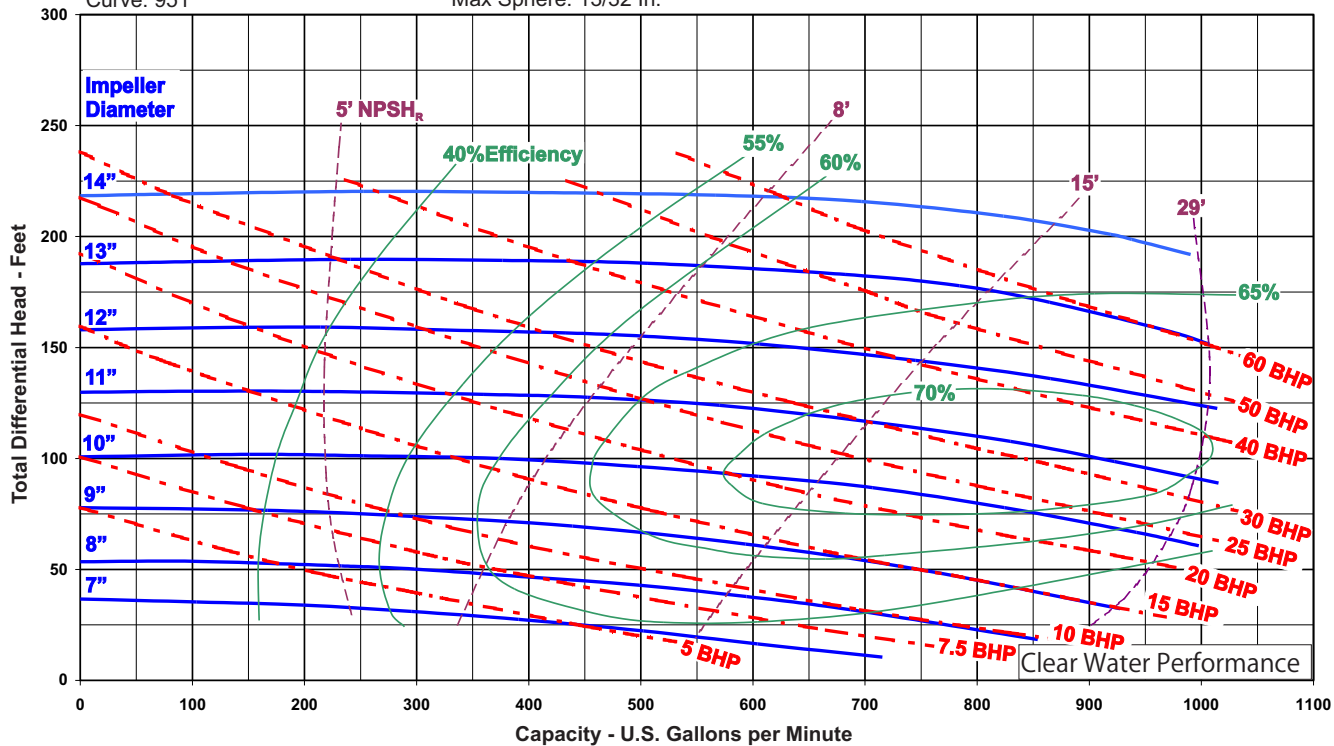

Magnum I
 5X4X14
 Speed: 800-2100 RPM
 Curve: 978

Open Impeller
 Dia: 14"
 Eye Area: 19.6 Sq. In.
 Max Sphere: 13/32 In.

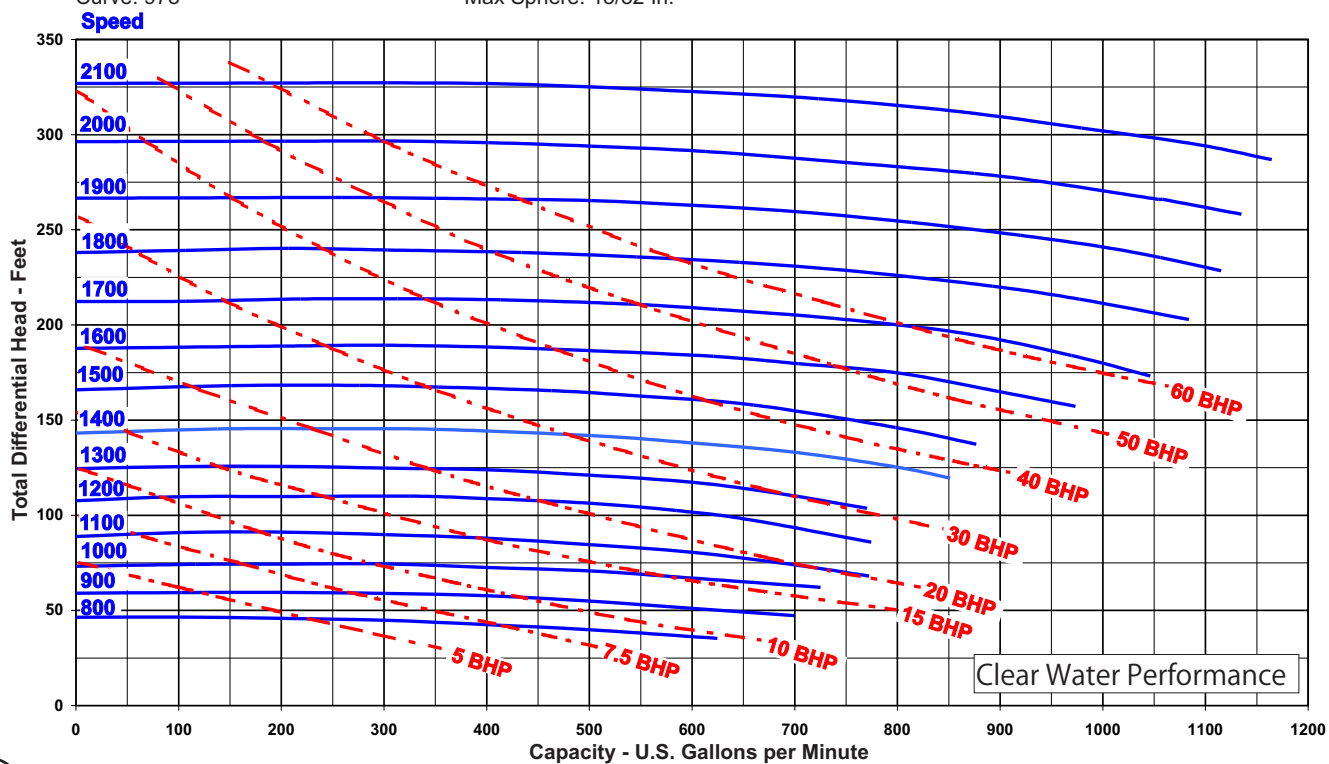

MISSION™ PRODUCTS

Magnum I
 6X5X11
 Speed: 1150 RPM
 Curve: 954

Open Impeller
 Dia: 8" to 11 1/2"
 Eye Area: 28.3 Sq. In.
 Max Sphere: 15/16 In.

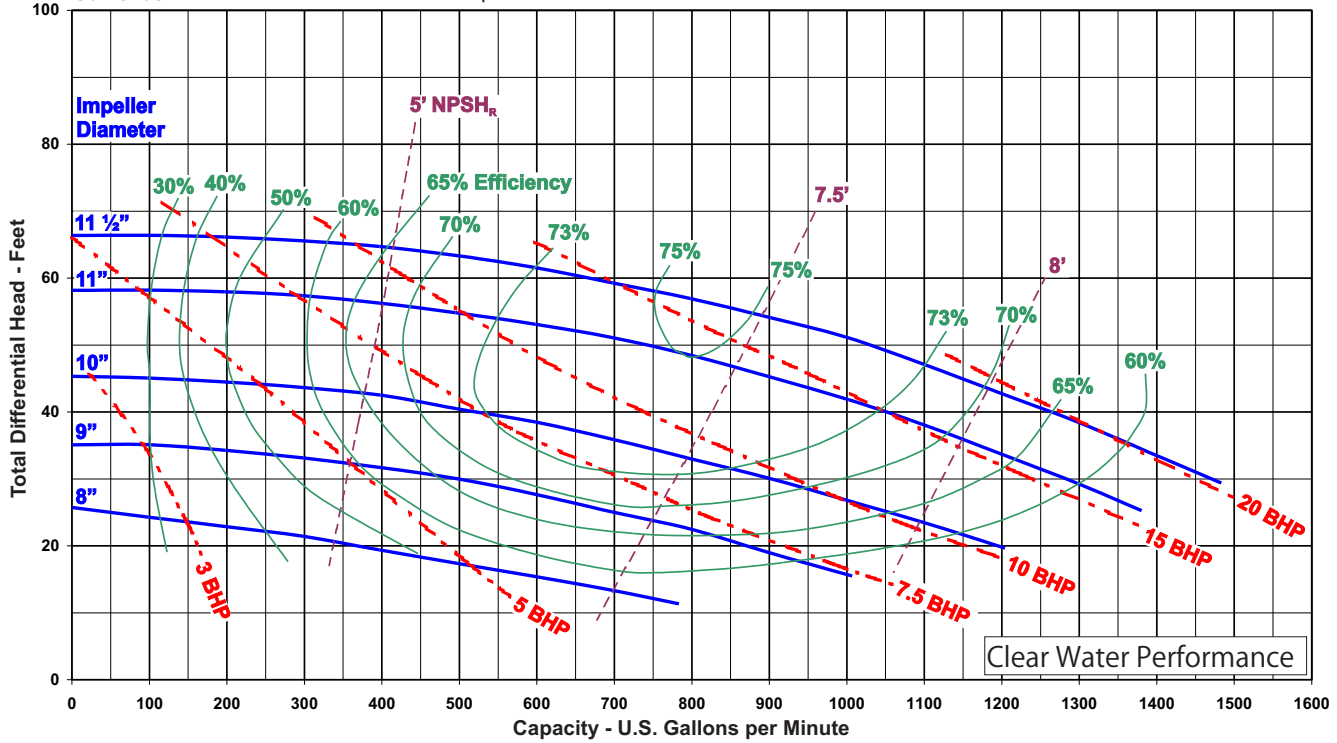

Magnum I
 6X5X11
 Speed: 1750 RPM
 Curve: 955

Open Impeller
 Dia: 8" to 11"
 Eye Area: 28.3 Sq. In.
 Max Sphere: 15/16 In.

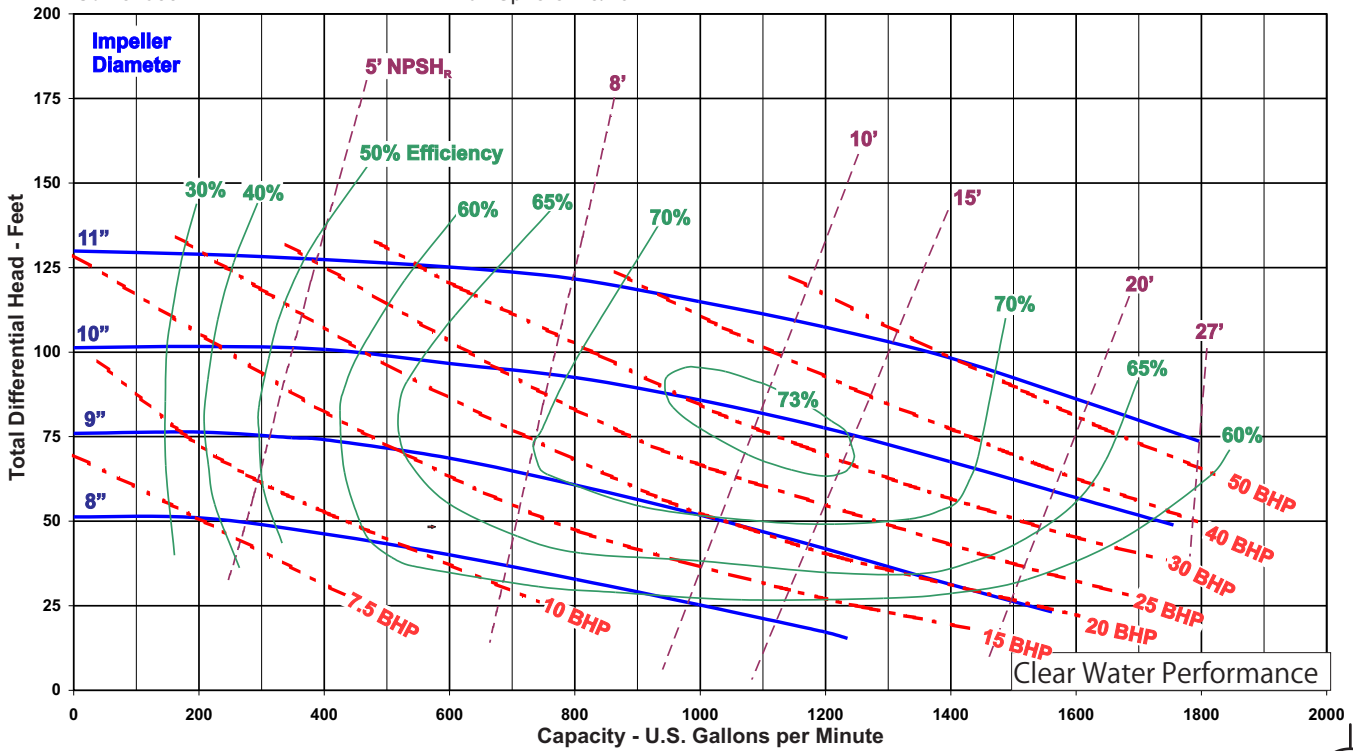

Magnum I
 6X5X11
 Speed: 800 - 1900 RPM
 Curve: 981

Open Impeller
 Dia: 11"
 Eye Area: 28.3 Sq. In.
 Max Sphere: 15/16 In.

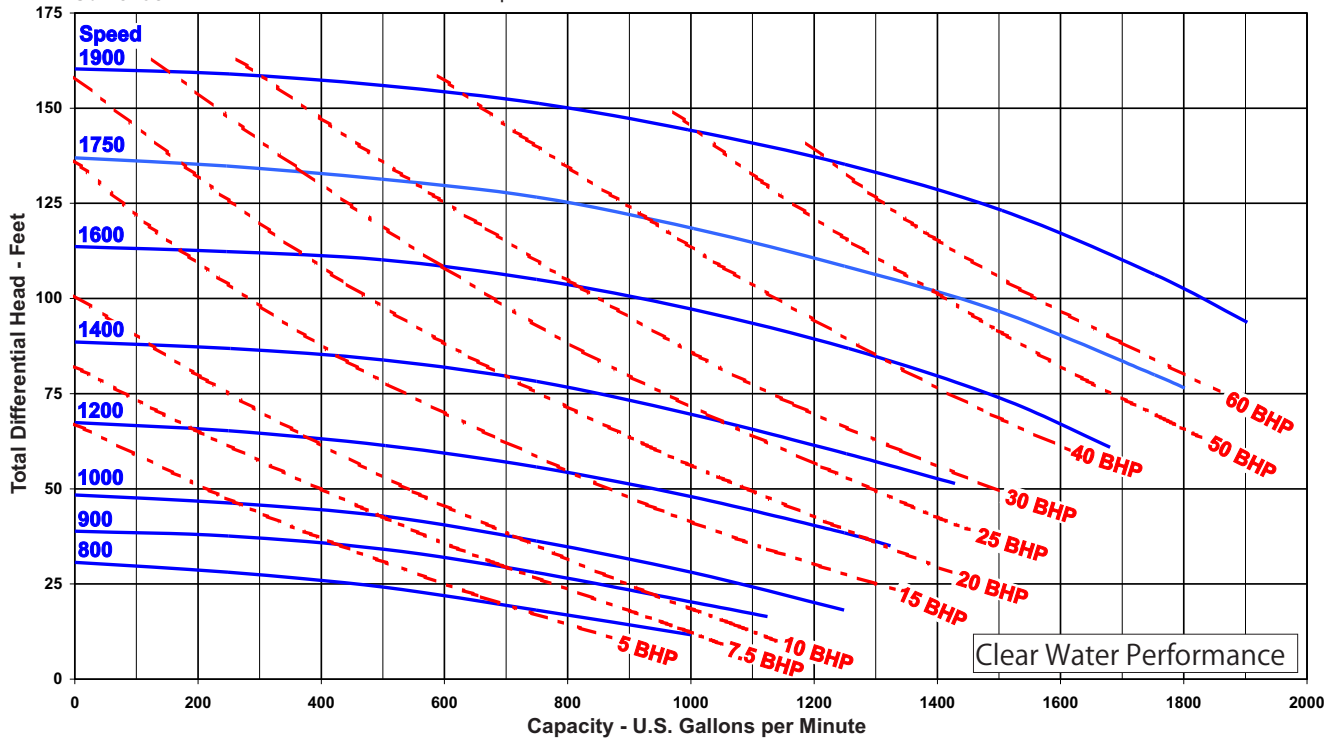

Magnum I
 6X5X14
 Speed: 1150 RPM
 Curve: 952

Open Impeller
 Dia: 10" to 14"
 Eye Area: 28.3 Sq. In.
 Max Sphere: 15/16 In.

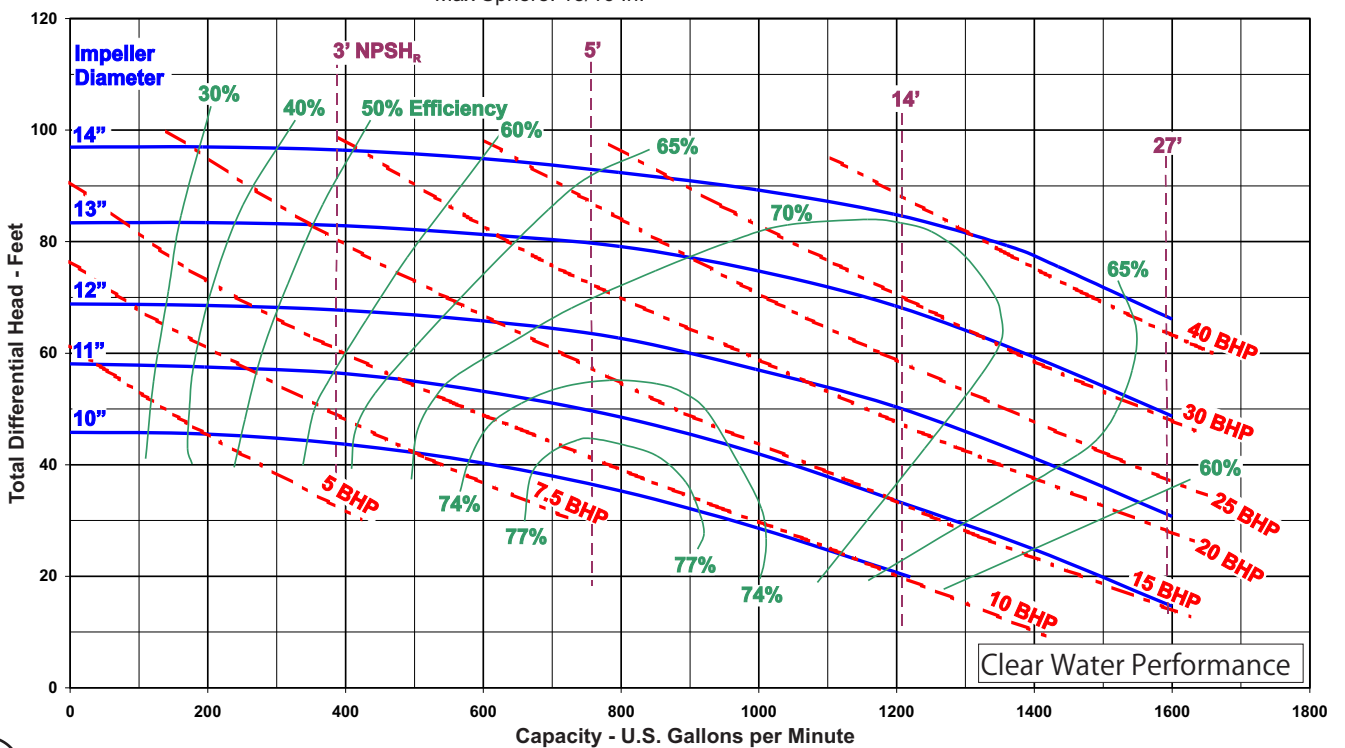

MISSION™ PRODUCTS

Magnum I
 6X5X14
 Speed: 1750 RPM
 Curve: 953

Open Impeller
 Dia: 10" to 14"
 Eye Area: 28.3 Sq. In.
 Max Sphere: 15/16 In.

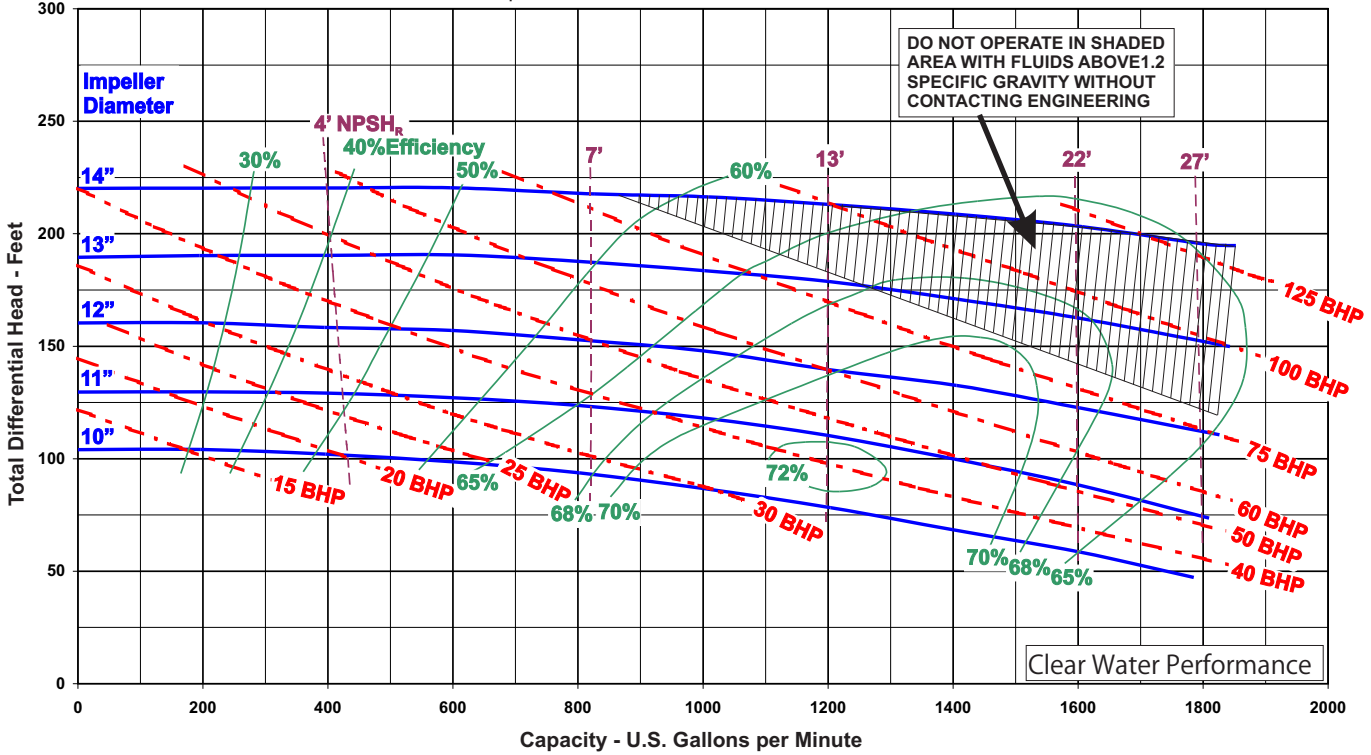

Magnum I
 6X5X14
 Speed: 800 - 1800 RPM
 Curve: 979

Open Impeller
 Dia: 14"
 Eye Area: 28.3 Sq. In.
 Max Sphere: 15/16 In.

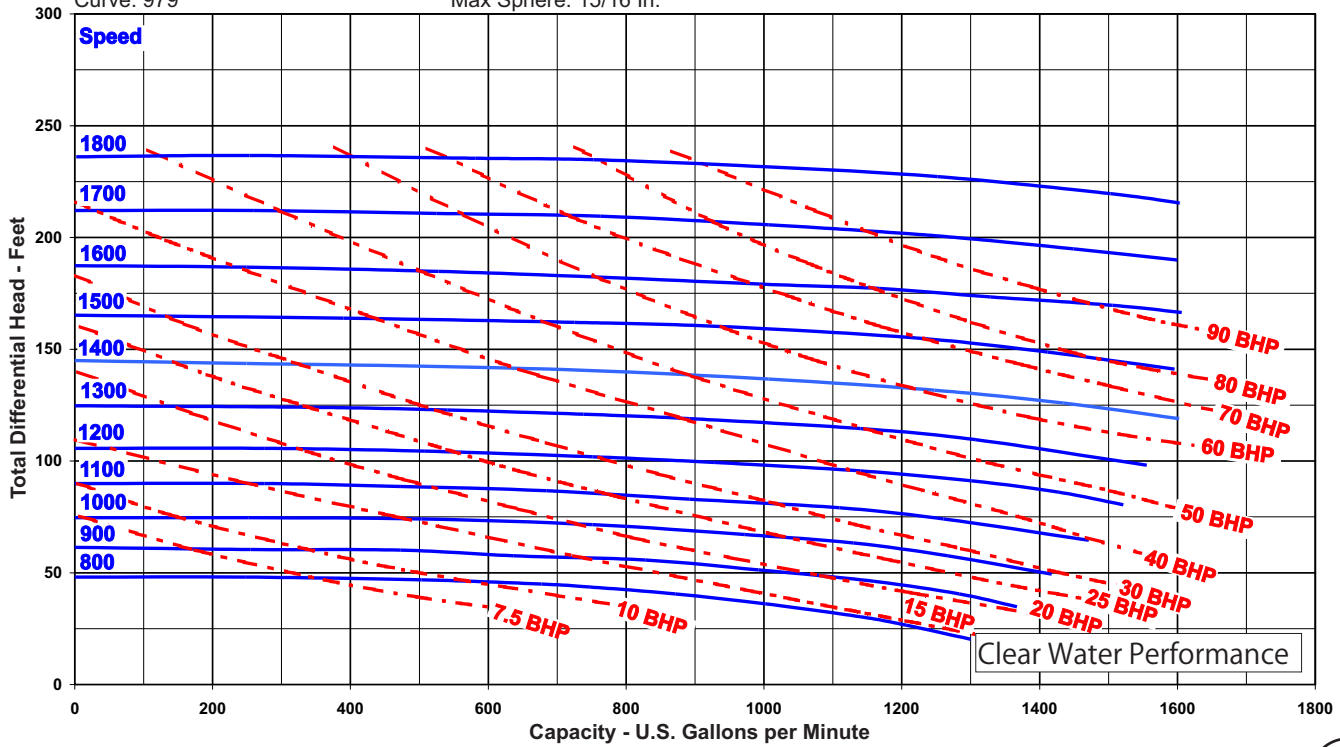

Magnum I
 8X6X11
 Speed: 1150 RPM
 Curve: 974

Open Impeller
 Dia: 8" to 11"
 Eye Area: 28.3 Sq. In.
 Max Sphere: 15/16 In.

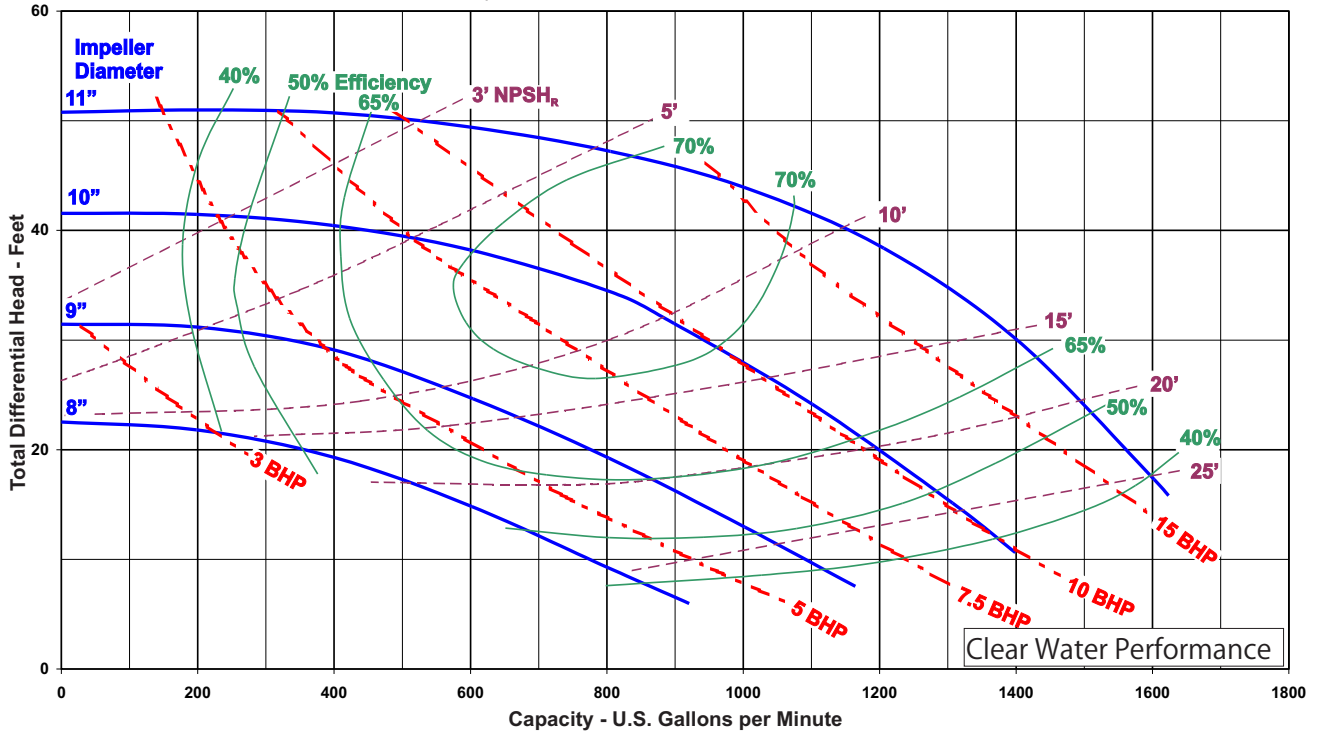

Magnum I
 8X6X11
 Speed: 1750 RPM
 Curve: 975

Open Impeller
 Dia: 8" to 11"
 Eye Area: 28.3 Sq. In.
 Max Sphere: 15/16 In.

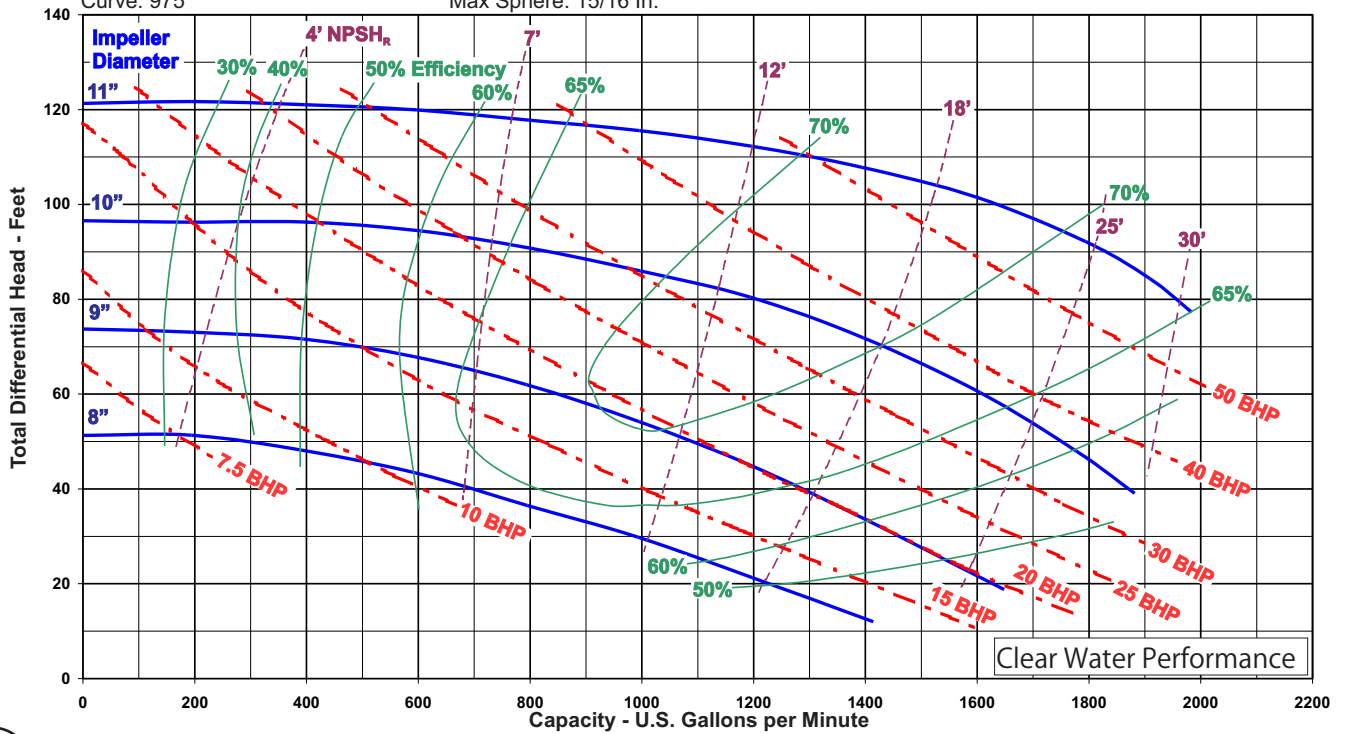

MISSION™ PRODUCTS

Magnum I
 8X6X11
 Speed: 800 - 1800 RPM
 Curve: 982

Open Impeller
 Dia: 11"
 Eye Area: 28.3 Sq. In.
 Max Sphere: 15/16 In.

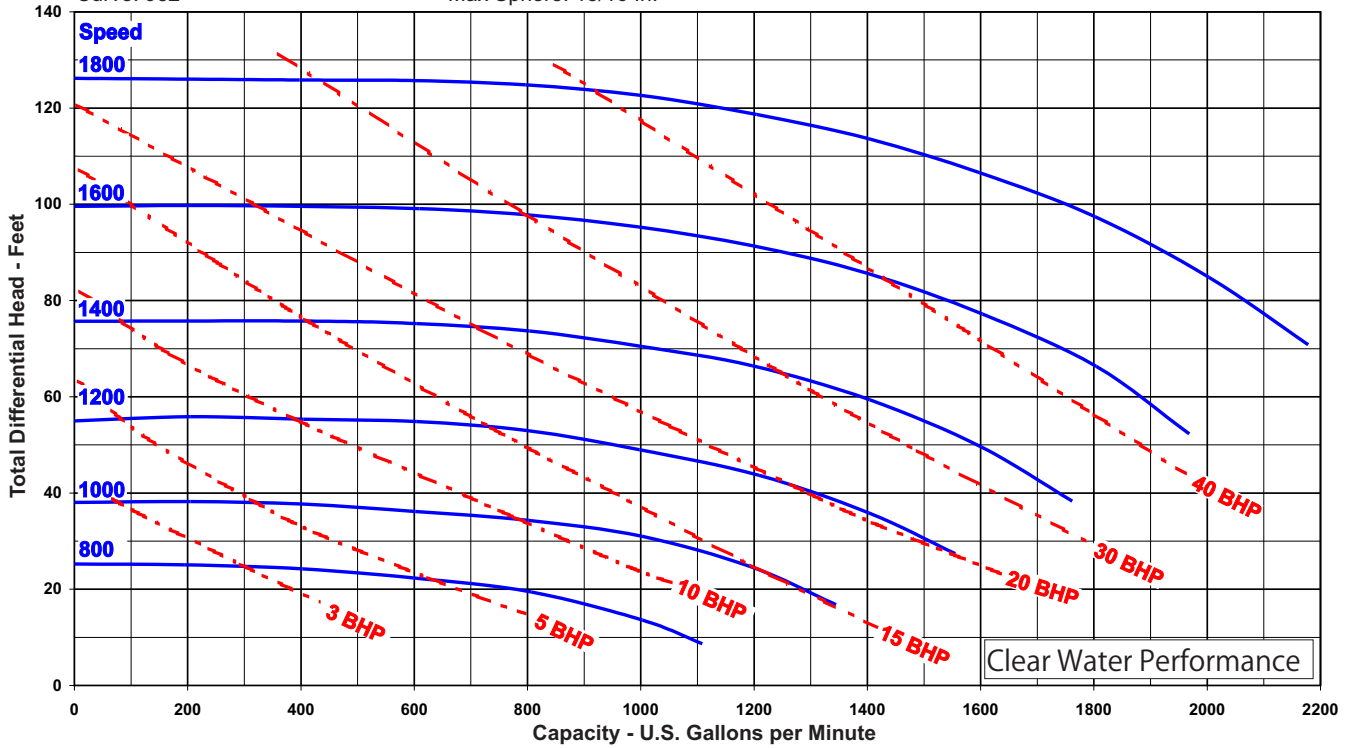

Magnum I
 8X6X14
 Speed: 1150 RPM
 Curve: 956

Open Impeller
 Dia: 10" to 14 1/8"
 Eye Area: 50.3 Sq. In.
 Max Sphere: 1 3/8 In.

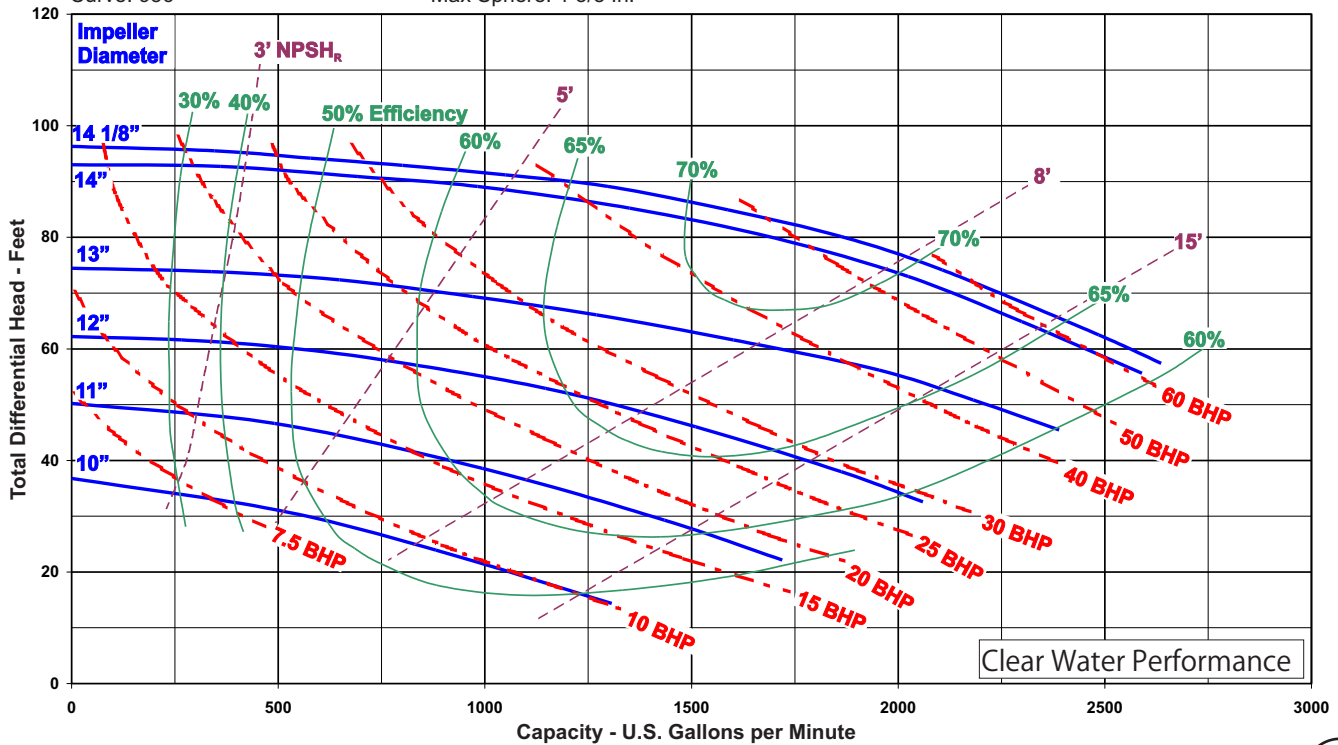

Magnum I
 8X6X14
 Speed: 1750 RPM
 Curve: 957

Open Impeller
 Dia: 10" to 14"
 Eye Area: 50.3 Sq. In.
 Max Sphere: 1 3/8 In.

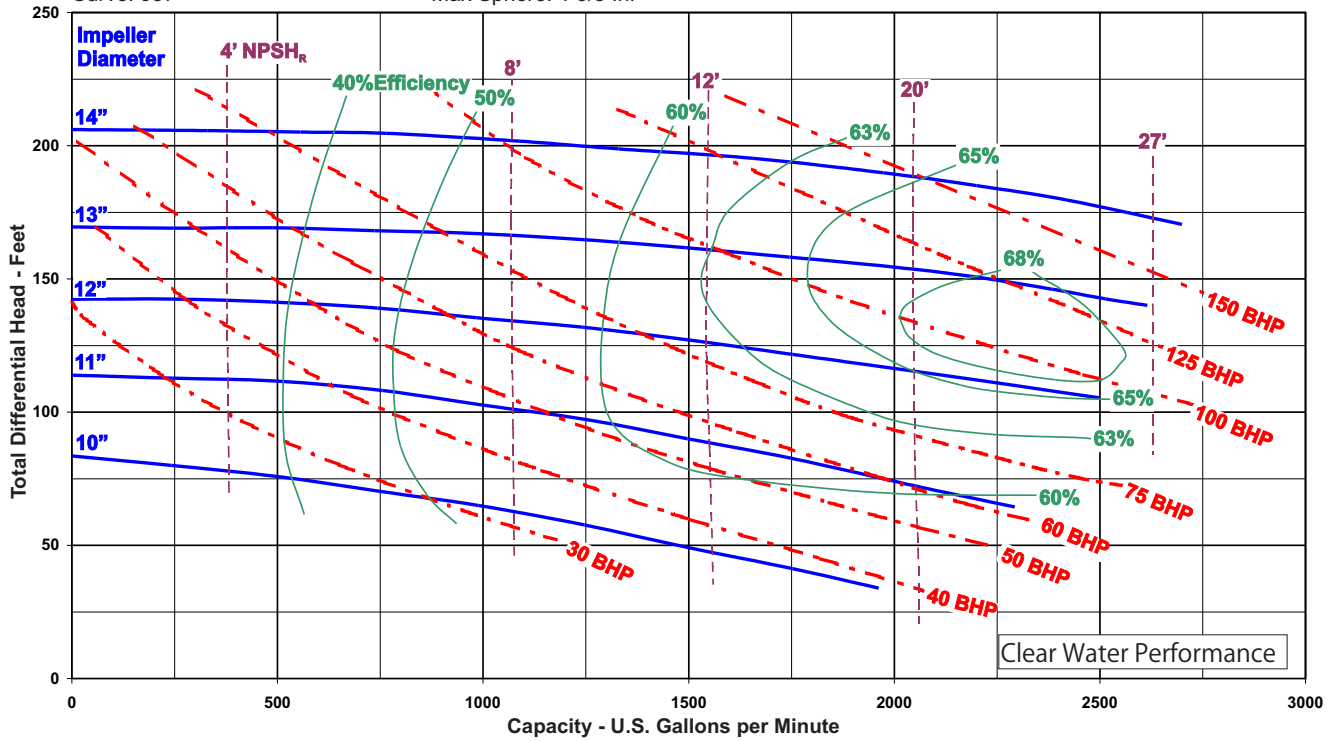

Magnum I
 8X6X14
 Speed: 800 - 1700 RPM
 Curve: 980

Open Impeller
 Dia: 14 1/8"
 Eye Area: 50.3 Sq. In.
 Max Sphere: 1 3/8 In.

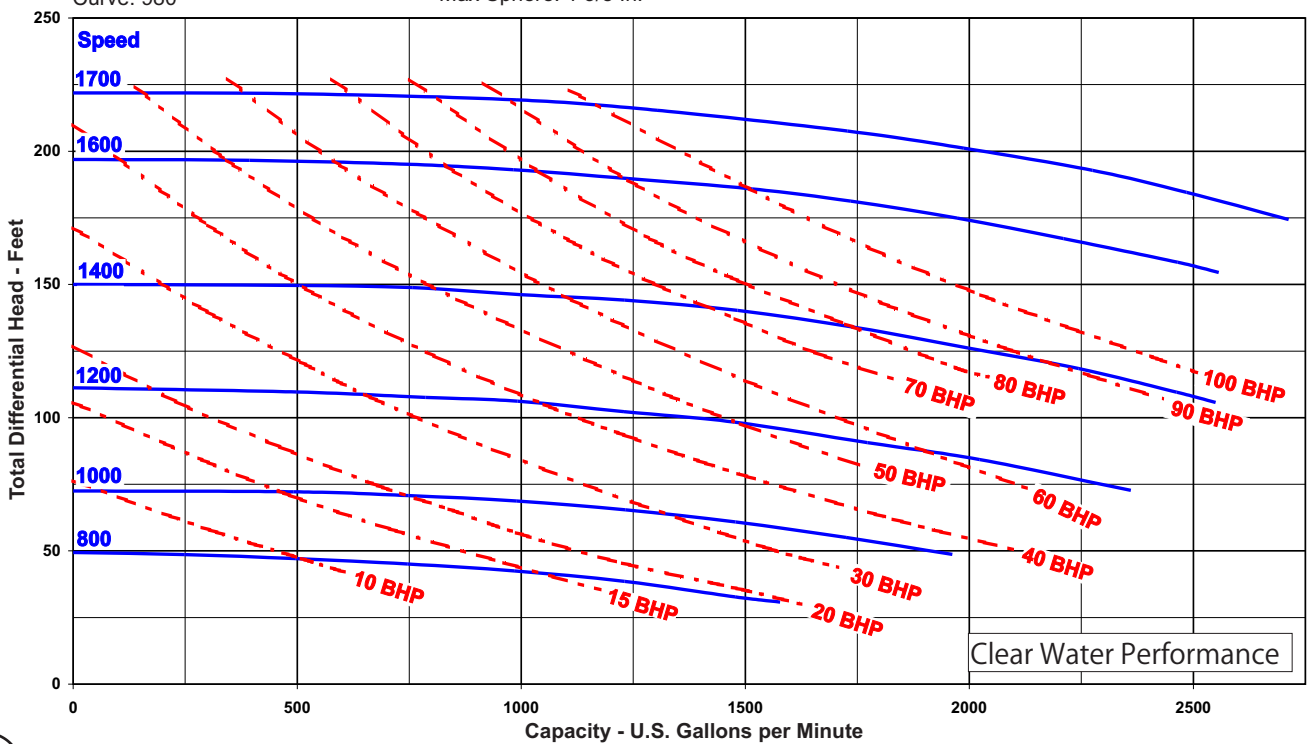

MISSION™ PRODUCTS

Magnum I
10X8X14
Speed: 1150 RPM
Curve: 993

Open Impeller
Dia: 12" to 14"
Eye Area: 63 Sq. In.
Max Sphere: 2 In.

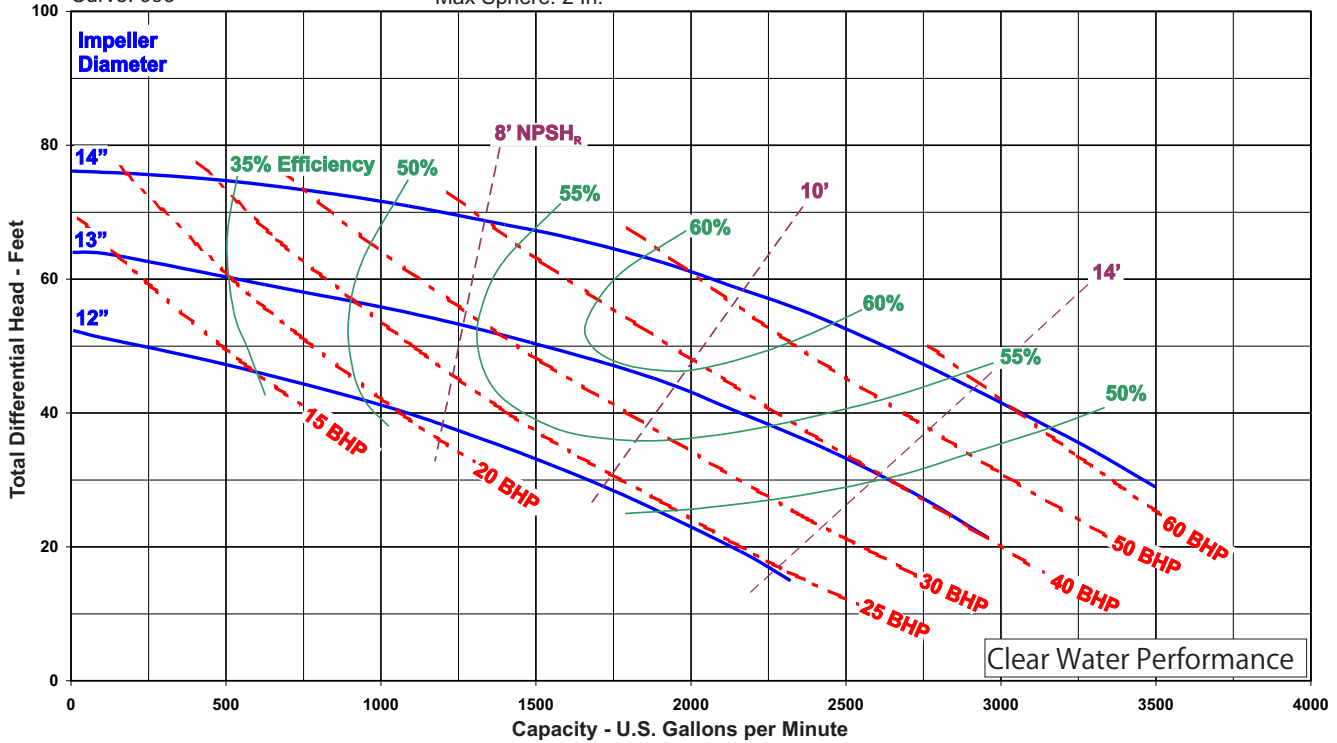

Magnum I
10X8X14
Speed: 1750 RPM
Curve: 994

Open Impeller
Dia: 12" to 14"
Eye Area: 63 Sq. In.
Max Sphere: 2 In.

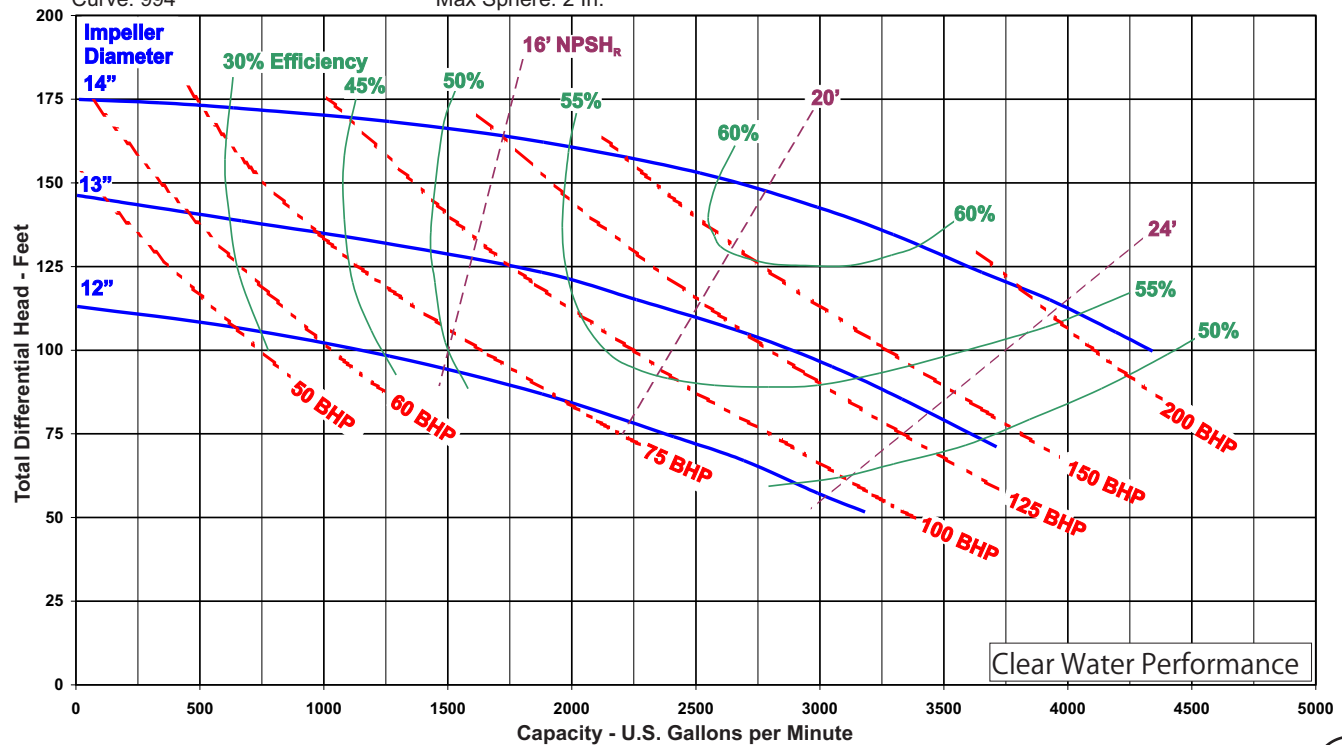

Magnum I
 10X8X14
 Speed: 800-1800 RPM
 Curve: 995

Open Impeller
 Dia: 14 1/8"
 Eye Area: 63 Sq. In.
 Max Sphere: 2 In.

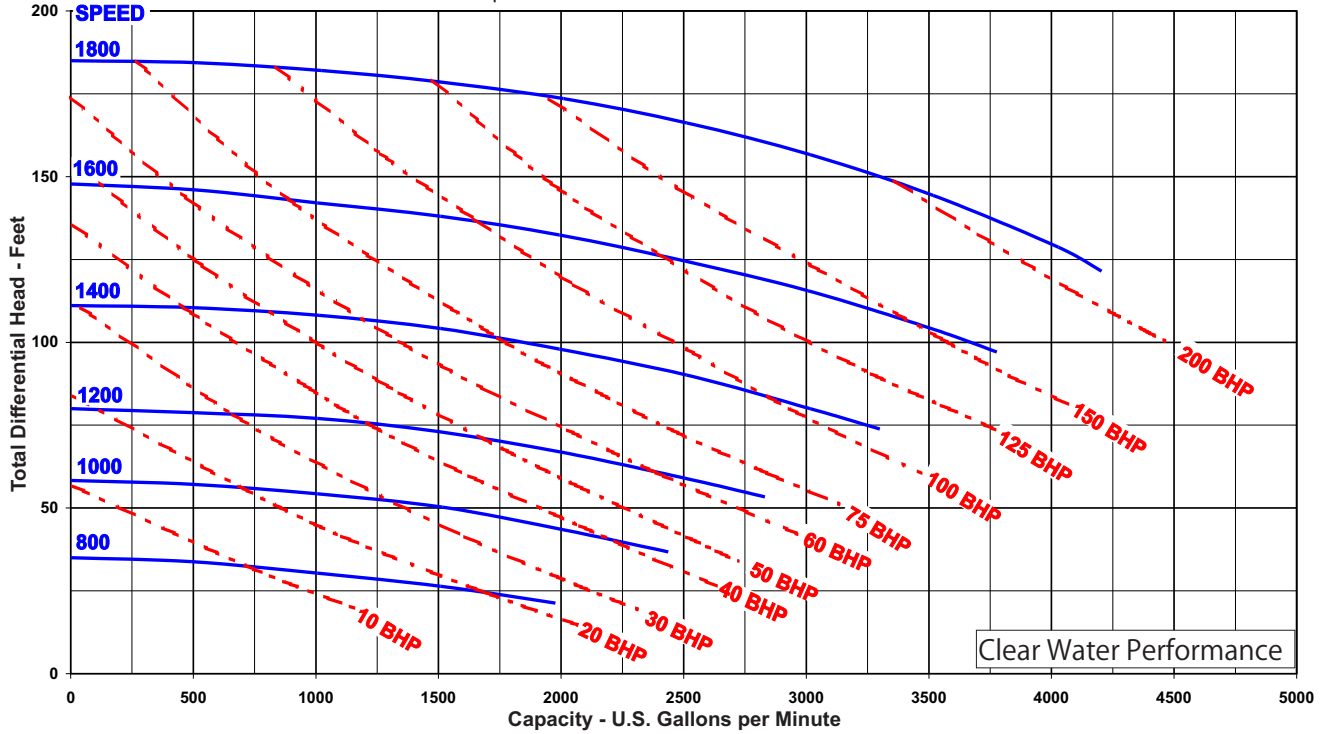

Magnum XP
 8X6X18
 Speed: 1750 RPM
 Curve: 86817

Open Impeller
 Dia: 15" to 18"
 Max Sphere: 3/4"

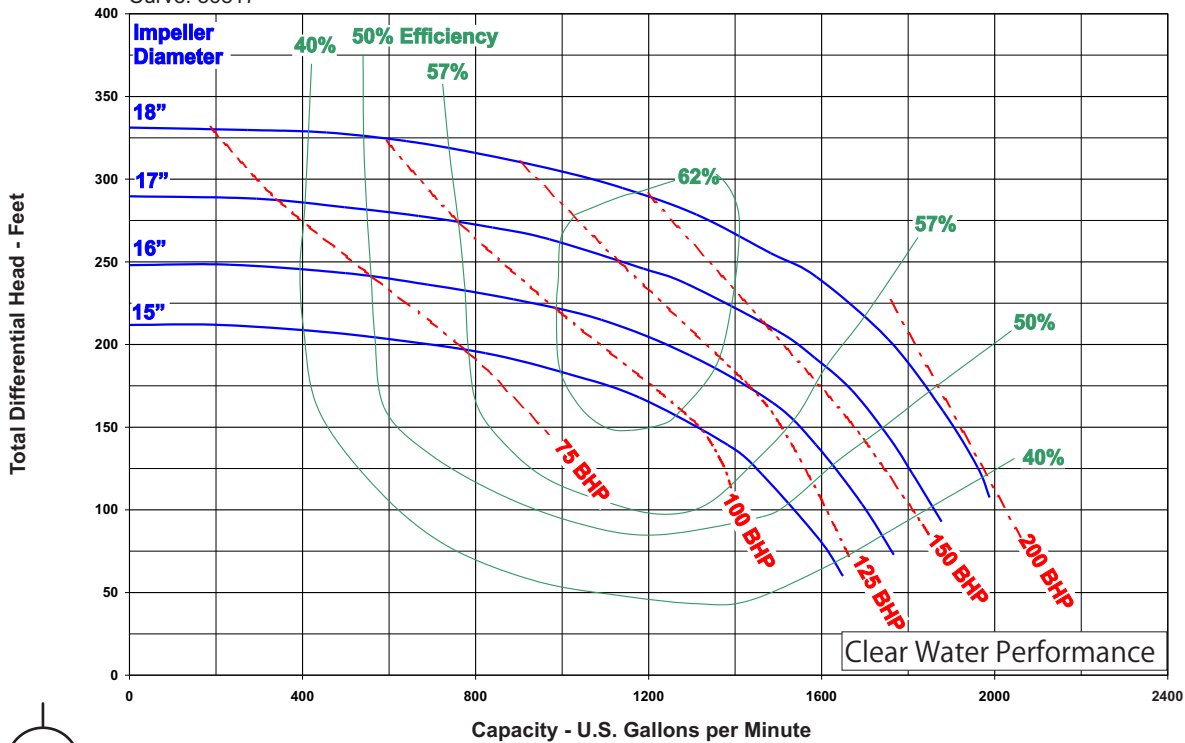

MISSION™ PRODUCTS

Magnum XP
12X10X23
Speed: 1200 RPM
Curve: XP010-C1-CATV2

Open Impeller
Dia: 20" to 23"

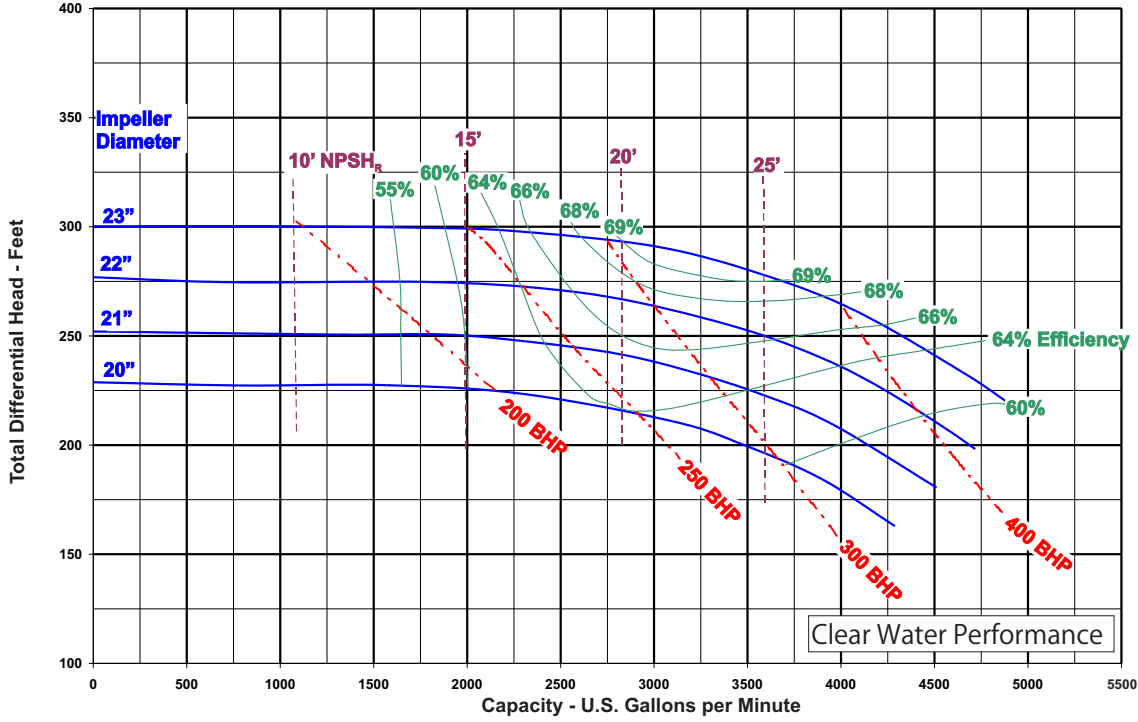

Magnum XP
12X10X23
Speed: 1400 RPM
Curve: XP010-E1-CAT

Open Impeller
Dia: 20" to 23"

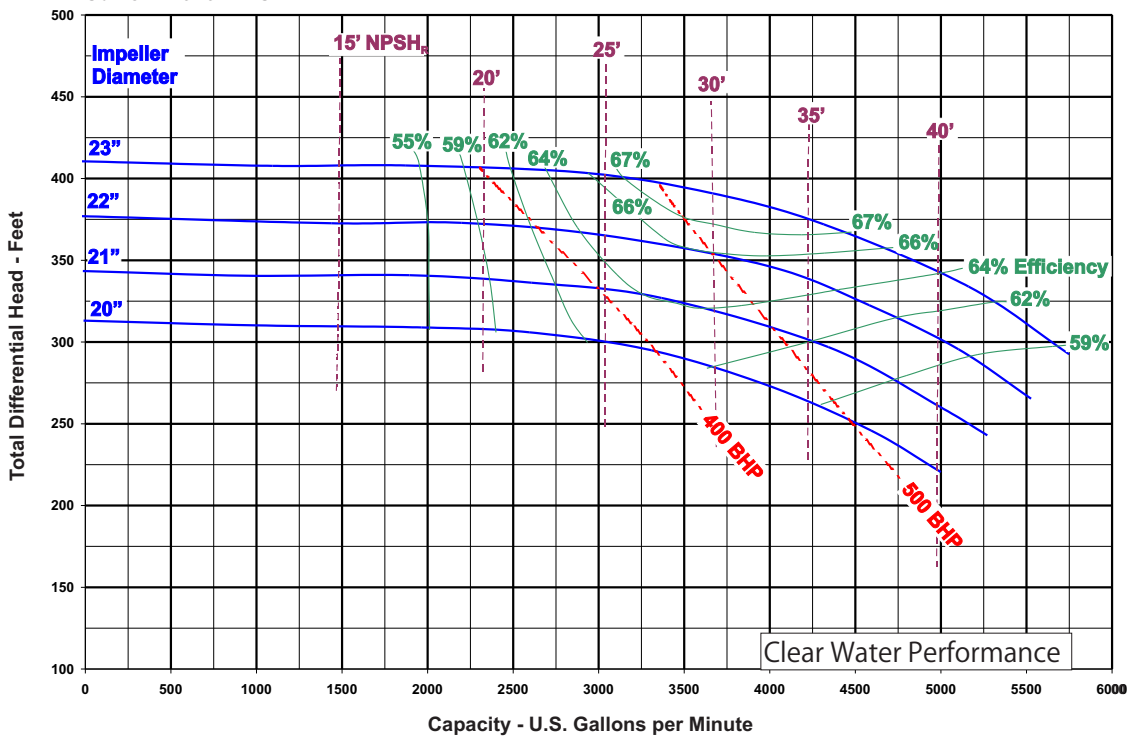

Magnum XP
 14X12X22
 Speed: 1200 RPM
 Curve: 1081

Open Impeller
 Dia: 18" to 22"
 Max Sphere: 1 5/8"

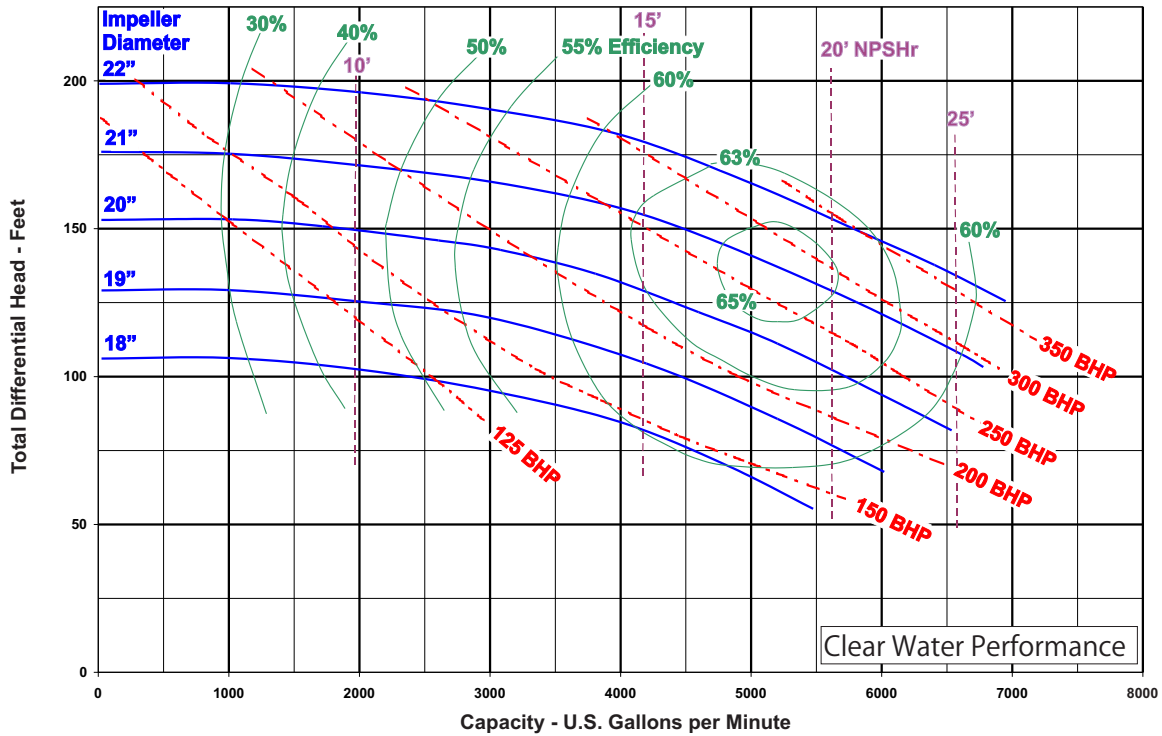

Magnum XP
 14X12X22
 Speed: 1000 -1400 RPM
 Curve: M1412VA

Open Impeller
 Dia: 22"
 Max Sphere: 1 5/8"

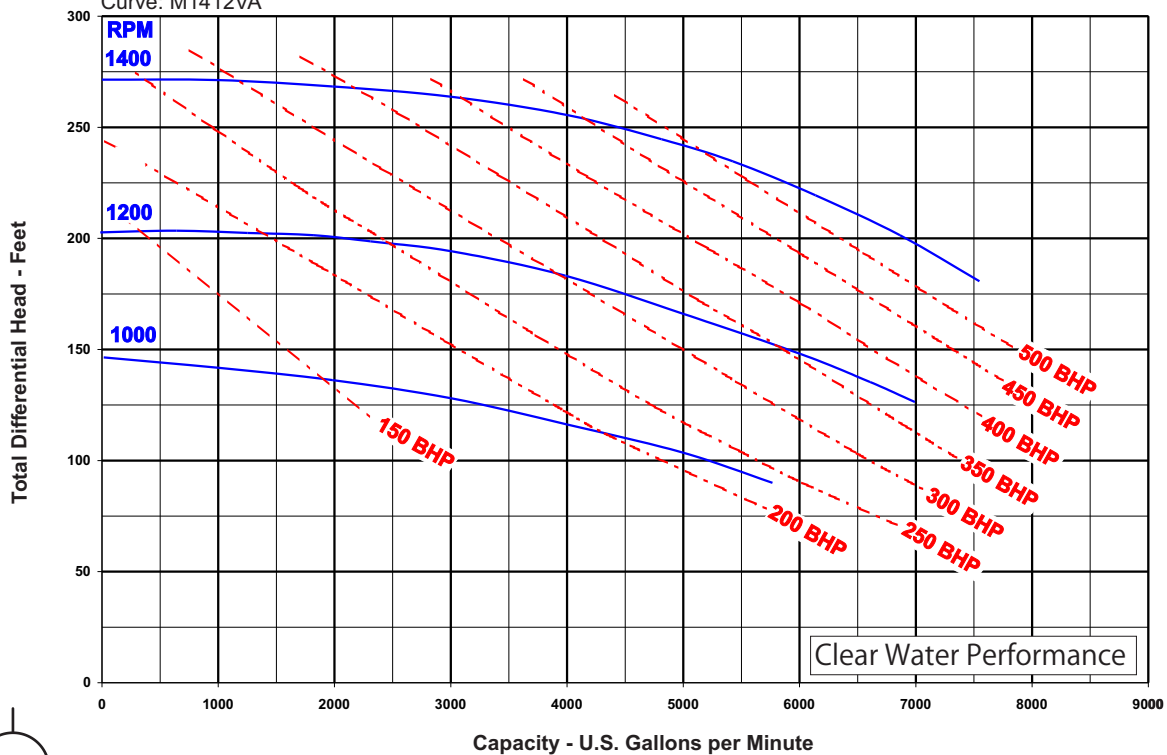

MISSION™ PRODUCTS

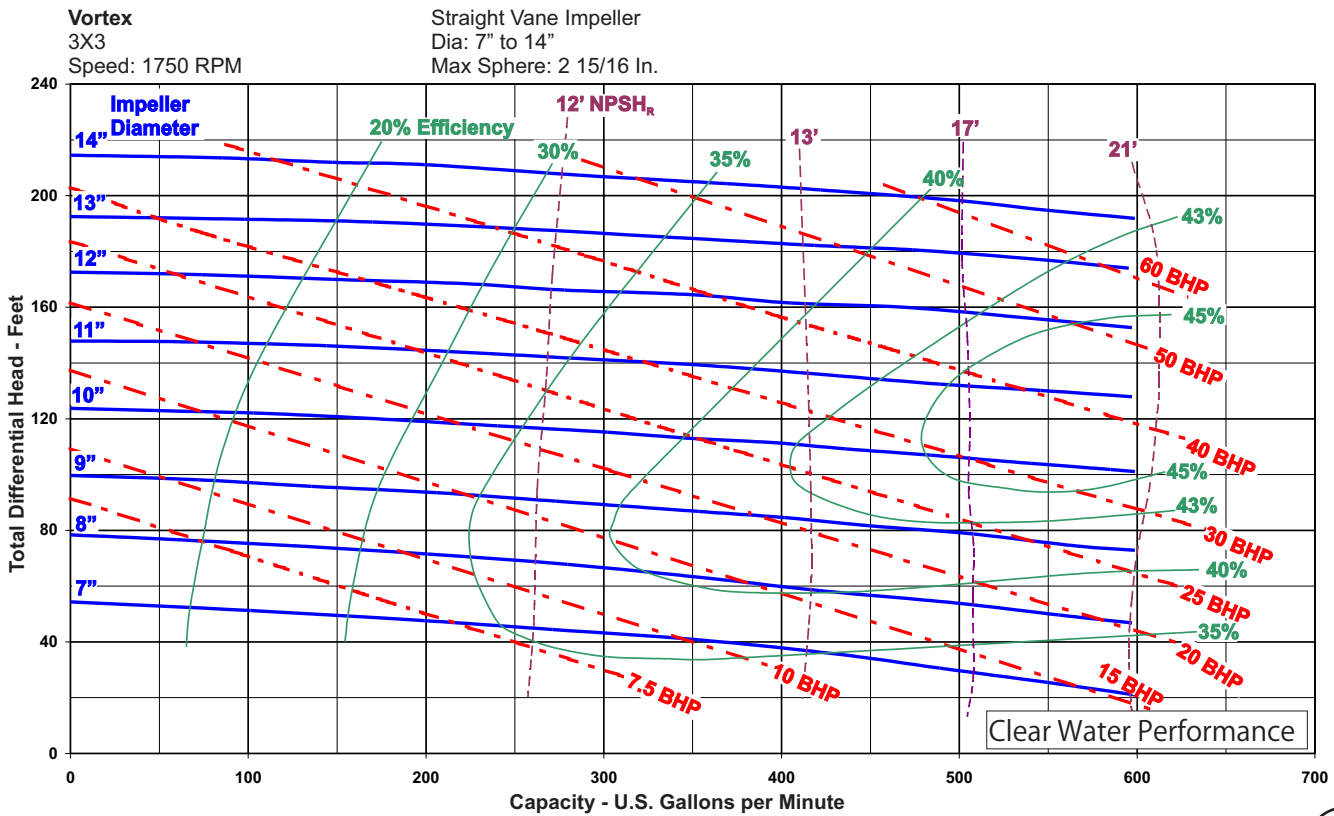
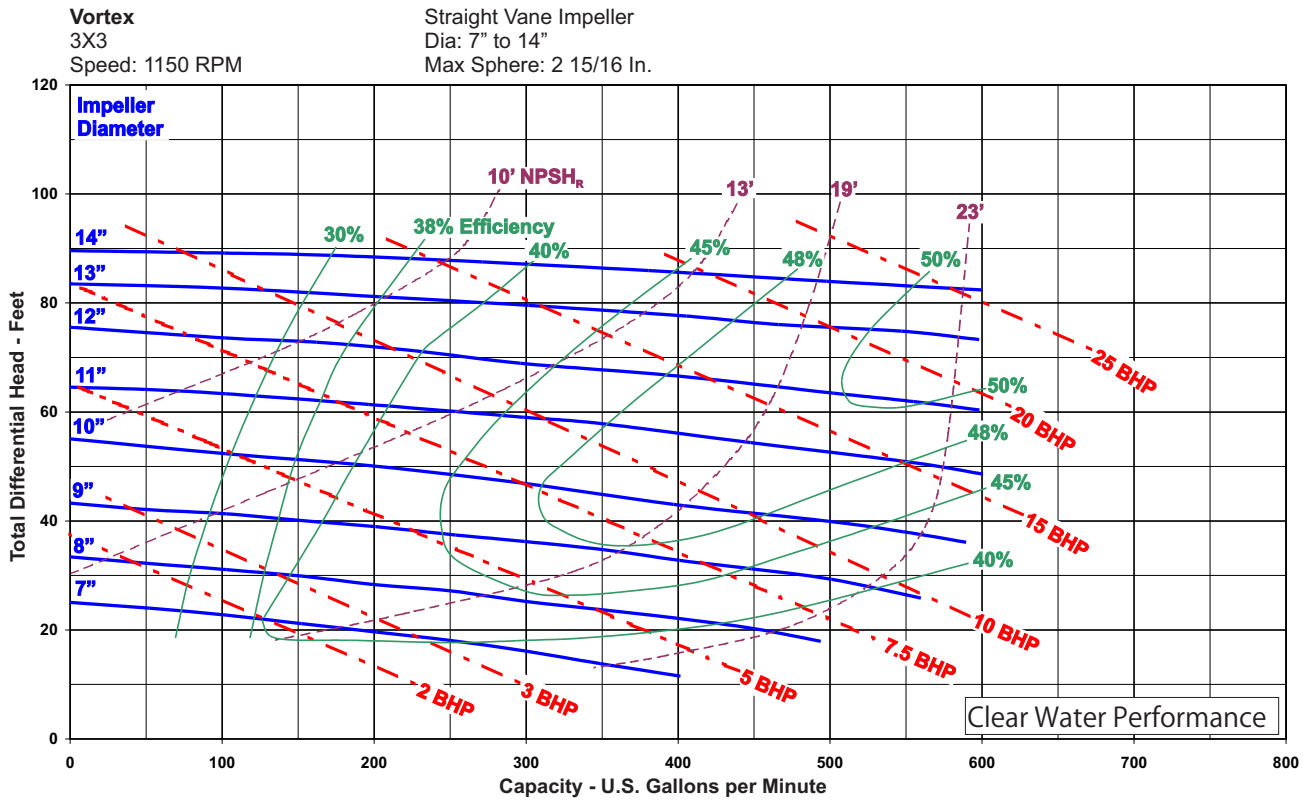

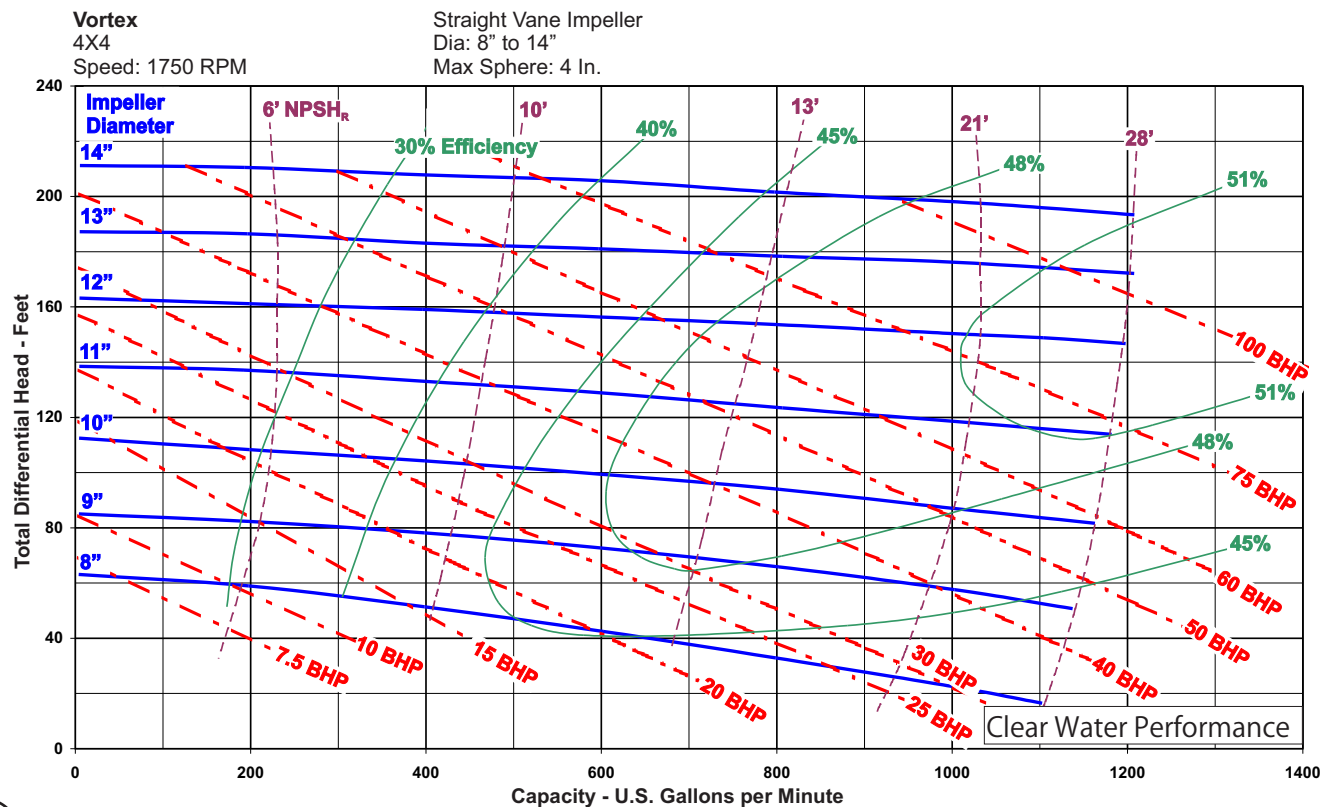
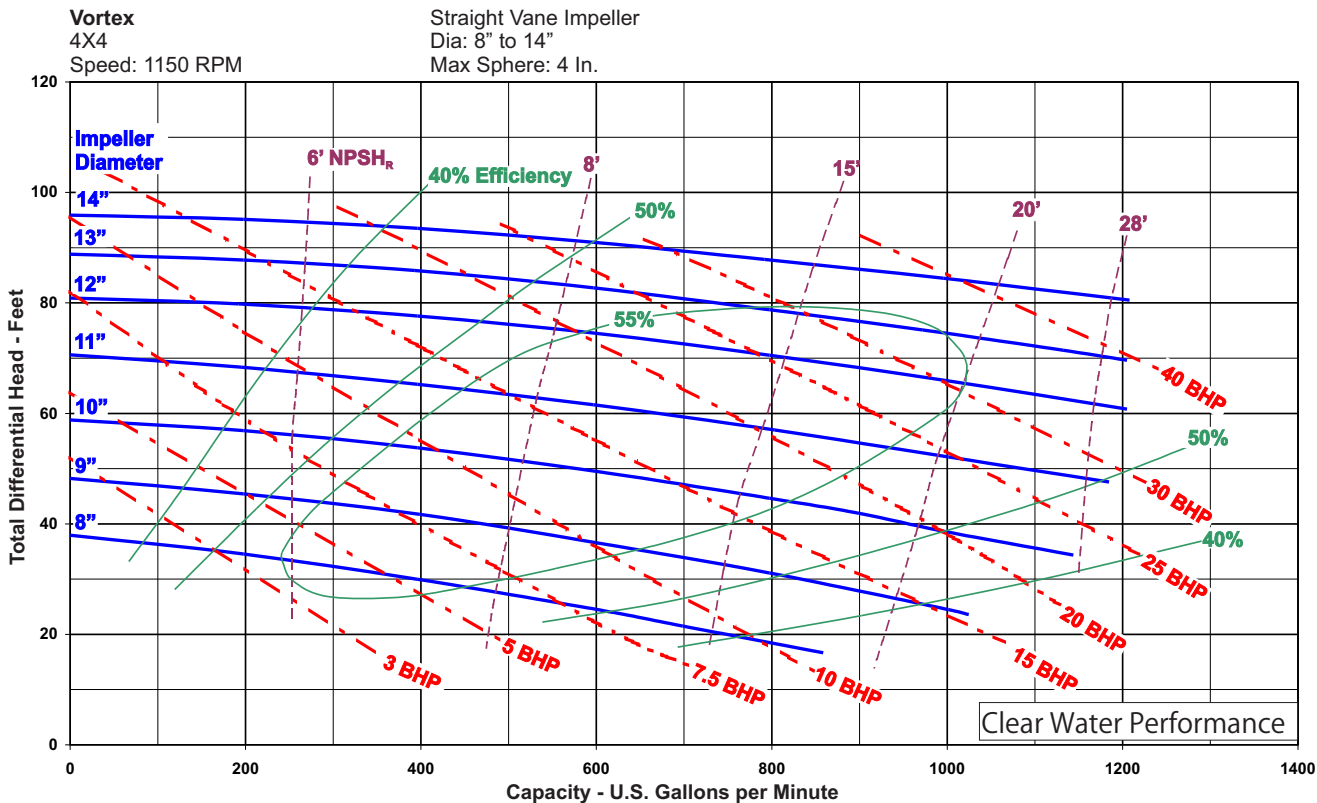

MISSION™ PRODUCTS

Vortex
6X6
Speed: 1150 RPM

Straight Vane Impeller
Dia: 9" to 14"
Max Sphere: 6 In.

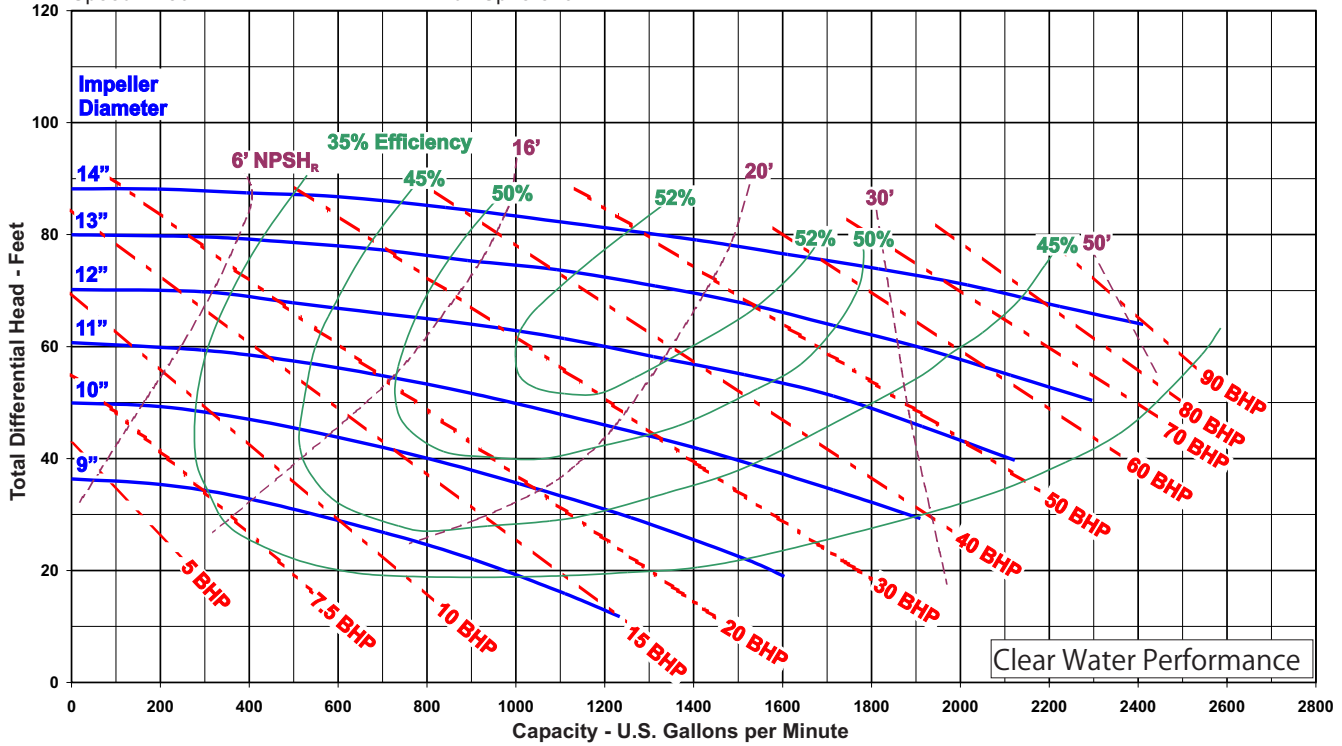

Vortex
6X6
Speed: 1750 RPM

Straight Vane Impeller
Dia: 9" to 14"
Max Sphere: 6 In.

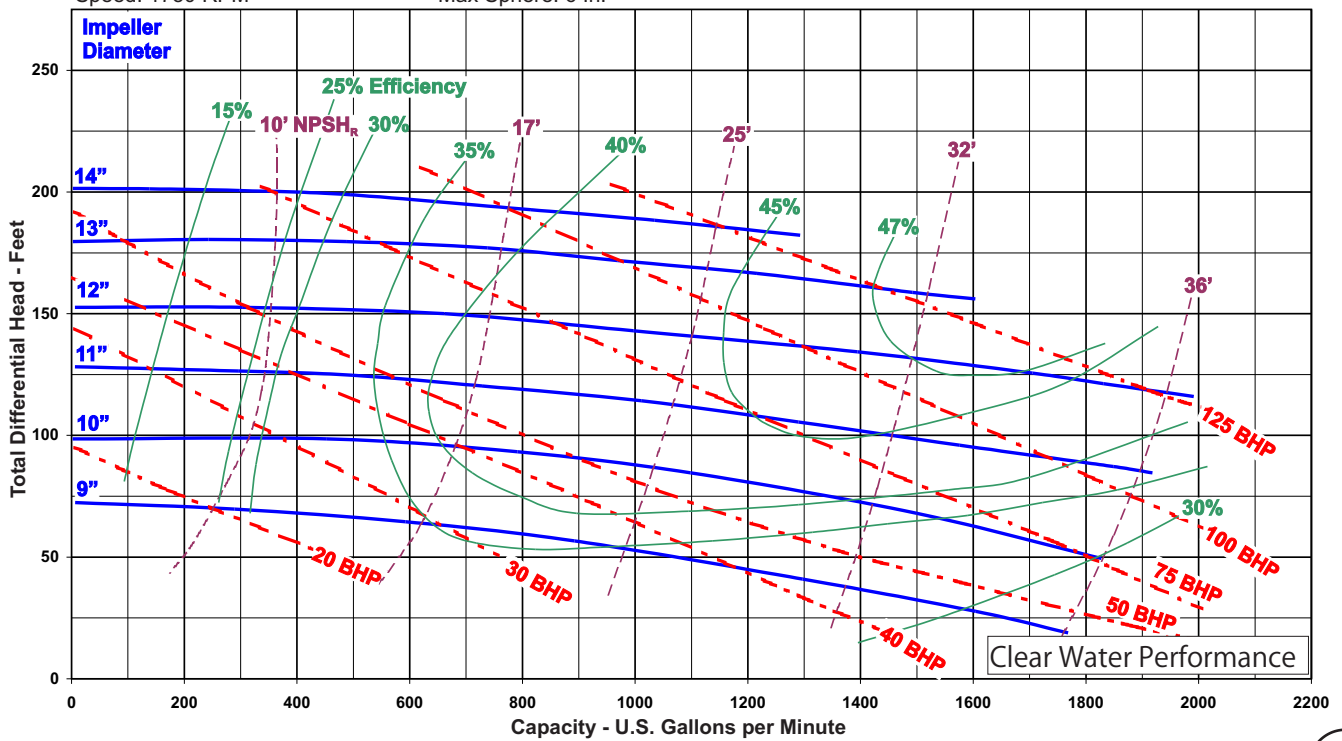

Dimensional Data

Magnum and 2500 Supreme Dimensions¹

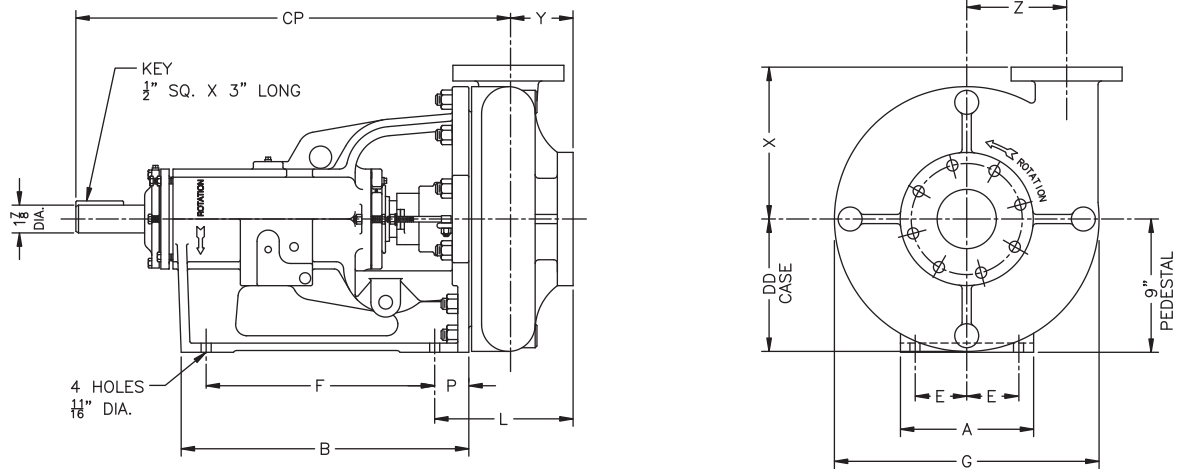

PUMP SIZE	Wt. Lbs.	PIPE FLANGES * SUCTION PIPE		PIPE FLANGES * DISCHARGE PIPE		A	B	E	F	G	L	P	X	Y	Z	CP	DD
		SIZE	DRILLING	SIZE	DRILLING												
3 x 2 x 13	440	3	4 HOLES 3/4\"DIA 6\" B.C.	2	4 HOLES 3/4\"DIA 4-3/4\" B.C.	9	19-5/8	3-1/2	15-7/16	17-7/8	8-3/4	2-5/16	10-1/4	3-3/4	7	29-1/4	9
4 x 3 x 13	436	4	8 HOLES 3/4\"DIA 7-1/2\" B.C.	3	4 HOLES 3/4\"DIA 6\" B.C.	9	19-5/8	3-1/2	15-7/16	17-7/8	9-3/8	2-5/16	10-1/4	4-1/4	6-3/4	29-3/8	9
5 x 4 x 14	485	5	8 HOLES 7/8\"DIA 8-1/2\" B.C.	4	8 HOLES 3/4\"DIA 7-1/2\" B.C.	9	19-5/8	3-1/2	15-7/16	19	10-3/4	2-5/16	11	5	6-1/8	30	9-11/16
6 x 5 x 11	507	6	8 HOLES 7/8\"DIA 9-1/2\" B.C.	5	8 HOLES 7/8\"DIA 8-1/2\" B.C.	9	19-5/8	3-1/2	15-7/16	17-7/8	12-1/16	2-5/16	11	5-3/4	6	30-5/8	9
6 x 5 x 14	550	6	8 HOLES 7/8\"DIA 9-1/2\" B.C.	5	8 HOLES 7/8\"DIA 8-1/2\" B.C.	9	19-5/8	3-1/2	15-7/16	21	12-1/16	2-5/16	11	5-3/4	6	30-5/8	10-1/2
8 x 6 x 11	583	8	8 HOLES 7/8\"DIA 11-3/4\" B.C.	6	8 HOLES 7/8\"DIA 9-1/2\" B.C.	9	19-5/8	3-1/2	15-7/16	20	13-1/4	2-5/16	14	6-1/4	8-3/8	31-1/4	10
8 x 6 x 14	616	8	8 HOLES 7/8\"DIA 11-3/4\" B.C.	6	8 HOLES 7/8\"DIA 9-1/2\" B.C.	9	19-5/8	3-1/2	15-7/16	23-9/16	13-1/4	2-5/16	14	6-1/4	8-3/8	31-1/4	12
10 x 8 x 14	810	10	12 HOLES 1\"DIA 14-1/4\" B.C.	8	8 HOLES 7/8\"DIA 11-3/4\" B.C.	9	19-5/8	3-1/2	15-7/16	22-3/8	13-11/16	2-5/16	14-3/16	6-11/16	8	31-1/4	11-3/16

* THE ABOVE DRILLING IS ANSI STANDARD 125 lb. CAST IRON OR ANSI SERIES 150 STEEL FLAT FACE. ALL FLANGE HOLES ARE THRU CLEARANCE HOLES.

Magnum and 2500 Supreme OB Skid Unitization Dimensions¹

Pump Size	CP	X	Y	Z	D
3X2X13	29-1/4	10-1/4	3-3/4	7	5-1/2
4X3X13	29-3/8	10-1/4	4-1/4	6-3/4	6-1/8
5X4X14	30	11	5	6-1/8	7-1/2
6X5X11	30-5/8	11	5-3/4	6	8-3/4
6X5X14	30-5/8	11	5-3/4	6	8-3/4
8X6X11	31-1/4	14	6-1/4	8-3/8	10
8X6X14	31-1/4	14	6-1/4	8-3/8	10
10X8X14	31-1/4	14-3/16	6-11/16	8	10.5

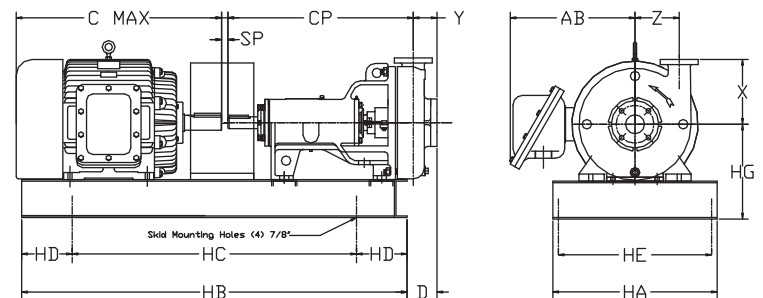

Motor Frames	BASE	HA	HB	HC	HD	HE	HG	C	SP*	AB**
182T-215T	OB-7	19	49-1/2	33-1/2	8	17-1/4	15	19	1	10.25
254T-286T	OB-1	19	55	39	8	17-1/4	15	27-1/2	1	13.25
324T-365T	OB-2	26	61	45	8	24-1/4	15	33-1/2	1	18.8
404T-405T	OB-3	26	66	50	8	24-1/4	16	38-1/2	1	20.5
444T-445T	OB-4	30	72	56	8	28-1/4	17	44-1/2	1	26.25

* Unless spacer coupling is utilized.

** Approximate maximum to outside of conduit box

Tolerances $\pm 1/8$ "

¹NOTE: Dimensions are for reference only. Certified drawings should be requested for construction purposes.

Sandmaster Dimensions¹

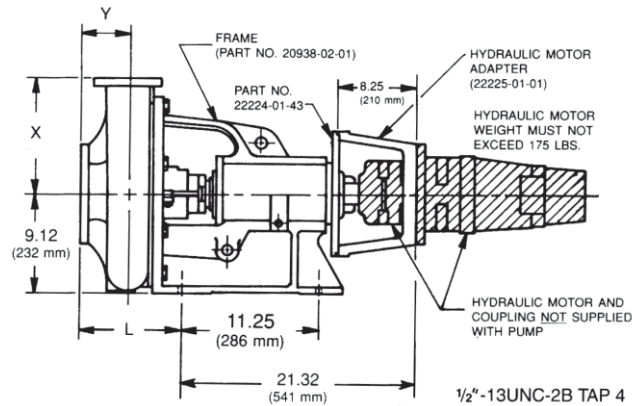

1/2"-13UNC-2B TAP 4 PLACES, AS SHOWN ON A 6 3/8 DIA. B.C.



Standard adapter for "C" flange hydraulic motor

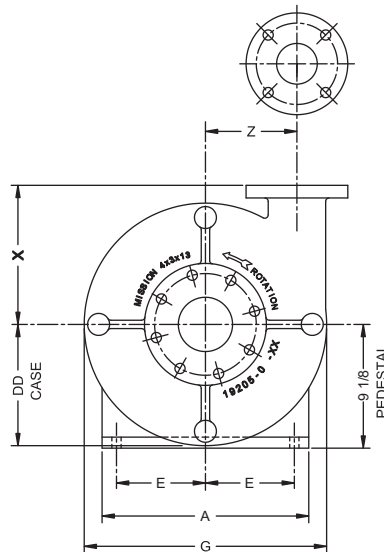
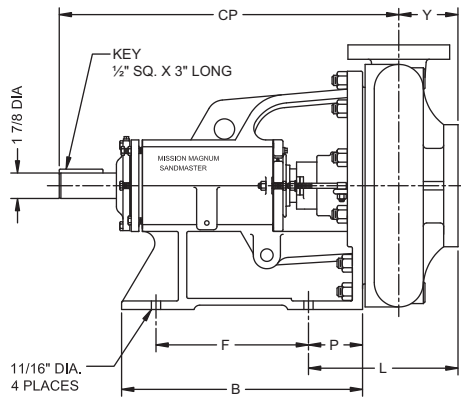

PUMP SIZE	Wt. Lbs.	PIPE FLANGES * SUCTION PIPE		PIPE FLANGES * DISCHARGE PIPE		A	B	E	F	G	L	P	X	Y	Z	CP	DD
		SIZE	DRILLING	SIZE	DRILLING												
3 x 2 x 13	475	3	4 HOLES 3/4" DIA. 6" B.C.	2	4 HOLES 3/4" DIA. 4-3/4" B.C.	15-1/4	17-3/4	6-9/16	11-1/4	17-7/8	10-7/16	4	10-1/4	3-3/4	7	25-1/16	8-15/16
4 x 3 x 13	491	4	8 HOLES 3/4" DIA. 7-1/2" B.C.	3	4 HOLES 3/4" DIA. 6" B.C.	15-1/4	17-3/4	6-9/16	11-1/4	17-7/8	11-1/16	4	10-1/4	4-1/4	6-3/4	25-1/8	8-15/16
5 x 4 x 14	520	5	8 HOLES 7/8" DIA. 8-1/2" B.C.	4	8 HOLES 3/4" DIA. 7-1/2" B.C.	15-1/4	17-3/4	6-9/16	11-1/4	19	12-7/16	4	11	5	6-1/8	25-13/16	9-1/2"
6 x 5 x 11	550	6	8 HOLES 7/8" DIA. 9-1/2" B.C.	5	8 HOLES 7/8" DIA. 8-1/2" B.C.	15-1/4	17-3/4	6-9/16	11-1/4	17-7/8	13-3/4	4	11	5-3/4	6	26-3/8	8-15/16
6 x 5 x 14	609	6	8 HOLES 7/8" DIA. 9-1/2" B.C.	5	8 HOLES 7/8" DIA. 8-1/2" B.C.	15-1/4	17-3/4	6-9/16	11-1/4	21	13-3/4	4	11	5-3/4	6	26-3/8	10-1/2"
8 x 6 x 11	659	8	8 HOLES 7/8" DIA. 11-3/4" B.C.	6	8 HOLES 7/8" DIA. 9-1/2" B.C.	15-1/4	17-3/4	6-9/16	11-1/4	20	14-15/16	4	14	6-1/4	8-3/8	27-1/16	10
8 x 6 x 14	701	8	8 HOLES 7/8" DIA. 11-3/4" B.C.	6	8 HOLES 7/8" DIA. 9-1/2" B.C.	15-1/4	17-3/4	6-9/16	11-1/4	23-9/16	14-15/16	4	14	6-1/4	8-3/8	27-1/16	11-13/16
10 x 8 x 14	705	10	12 HOLES 1" DIA. 14-1/4" B.C.	8	8 HOLES 7/8" DIA. 11-3/4" B.C.	15-1/4	17-3/4	6-9/16	11-1/4	22-3/8	15-3/8	4	14-3/16	6-11/16	8	27-1/16	11-3/16

* THE ABOVE DRILLING IS ANSI STANDARD 125 lb. CAST IRON OR ANSI SERIES 150 STEEL FLAT FACE. ALL FLANGE HOLES ARE THRU CLEARANCE HOLES.

¹NOTE: Dimensions are for reference only. Certified drawings should be requested for construction purposes.

Vortex Dimensions¹

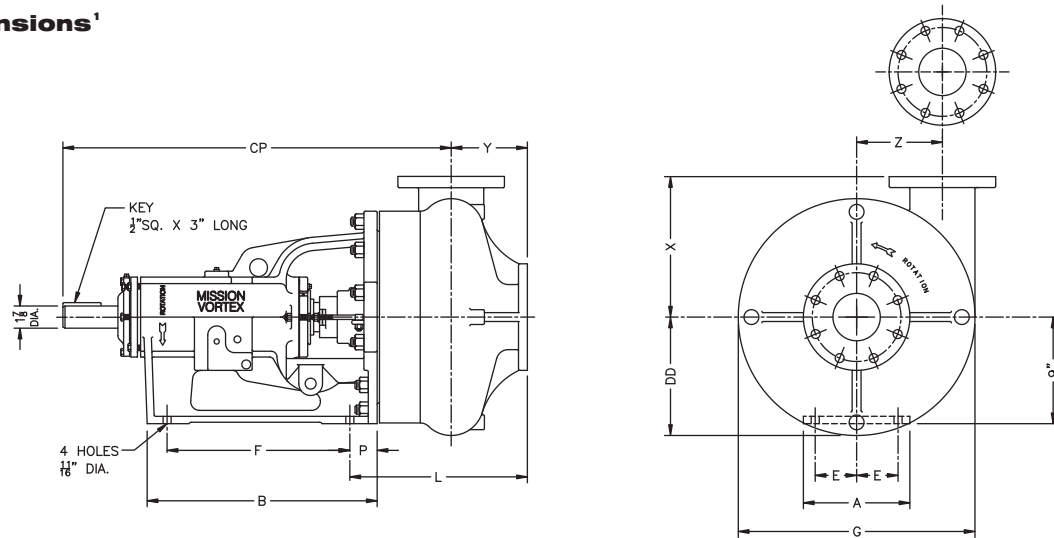

PUMP SIZE	Wt. Lbs.	PIPE FLANGES * DISCHARGE PIPE SIZE	DRILLING	PIPE FLANGES * SUCTION PIPE SIZE	DRILLING	A	B	E	F	G	L	P	X	Y	Z	CP	DD
3 x 3	505	3	4 HOLES 3/4\"DIA 6\" B.C.	3	4 HOLES 3/4\"DIA 6\" B.C.	9	19-7/16	3-1/2	15-7/16	19	13-15/16	2-5/16	11	6-1/4	7-1/4	32	9-1/2
4 x 4	566	4	8 HOLES 3/4\"DIA 7-1/2\" B.C.	3	8 HOLES 3/4\"DIA 7-1/2\" B.C.	9	19-7/16	3-1/2	15-7/16	20	15	2-5/16	11-7/8	6-7/16	7-1/4	32-13/16	10
6 x 6	618	6	8 HOLES 7/8\"DIA 9-1/2\" B.C.	6	8 HOLES 7/8\"DIA 9-1/2\" B.C.	9	19-7/16	3-1/2	15-7/16	22	17-3/4	2-5/16	13-7/8	7-13/16	7-1/4	34-3/16	11

* THE ABOVE DRILLING IS ANSI STANDARD 125 lb. CAST IRON OR ANSI SERIES 150 STEEL FLAT FACE. ALL FLANGE HOLES ARE THRU CLEARANCE HOLES

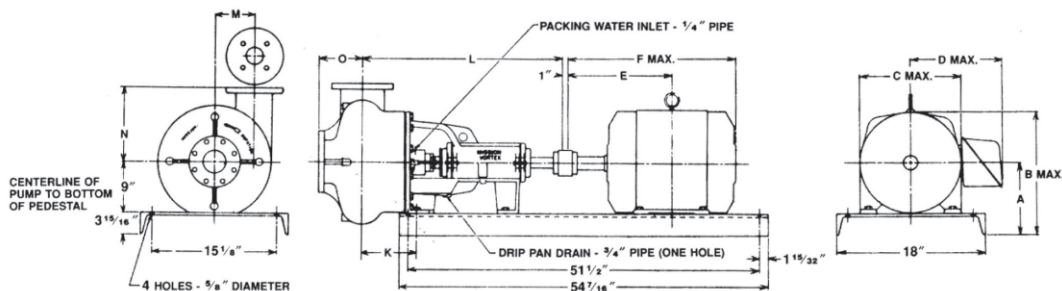

PUMP SIZE	PIPE FLANGES * DISCHARGE PIPE SIZE	DRILLING	PIPE FLANGES * SUCTION PIPE SIZE	DRILLING	K	L	M	N	O
3x3	3	4 Holes 3/4 D-6 B.C.	3	4 Holes 3/4 D-6 B.C.	7 11/16	32	7 1/4	11	6 1/4
4x4	4	8 Holes 3/4 D-7-1/2 B.C.	4	8 Holes 3/4 D-7-1/2 B.C.	8 9/16	33 1/4	7 1/4	11 7/8	6 7/16
6x6	6	8 Holes 7/8 D-9-1/2 B.C.	6	8 Holes 7/8 D-9-1/2 B.C.	9 15/16	34 1/4	7 1/4	13 7/8	7 9/16

* The above drilling is ANSI standard 125lb. cast iron or ANSI series 150 flat face steel flange.

Motor Frame	Base No.	A	B	C	D	E	F
143T	15901-3	12-15/16	16-9/16	7-3/4	7-15/16	6-1/2	13-1/4
145T	15901-3	12-15/16	16-9/16	7-3/4	7-15/16	7	14-1/4
182T	15901-3	12-15/16	17-9/16	9-3/8	7-1/4	7-3/4	14-9/16
184T	15901-3	12-15/16	17-9/16	9-3/8	7-1/4	8-1/4	15-9/16
213T	15901-3	12-15/16	18-7/16	11	9-1/4	9-5/8	17-7/8
215T	15901-3	12-15/16	18-7/16	11	9-1/4	10-3/8	19-7/16
254T	15901-3	12-15/16	19-7/16	13	10-1/2	12-3/8	22-3/4
256T	15901-3	12-15/16	19-7/16	13	10-1/2	13-1/4	24-9/16
284T	15901-3	12-15/16	20-5/32	14-1/2	12-5/16	14-1/8	26-5/8
284TS	15901-3	12-15/16	20-5/32	14-1/2	12-5/16	12-3/4	25-1/4
286T	15901-3	12-15/16	20-5/32	14-1/2	12-5/16	14-7/8	28-1/8
286TS	15901-3	12-15/16	20-5/32	14-1/2	12-5/16	13-1/2	26-3/4
324T	15901-3	12-15/16	21-3/8	16-7/8	14-7/16	15-3/4	28-15/16
324TS	15901-3	12-15/16	21-3/8	16-7/8	14-7/16	14-1/4	28-1/8
326T	15901-3	12-15/16	21-3/8	16-7/8	14-7/16	16-1/2	31-1/8
326TS	15901-3	12-15/16	21-3/8	16-7/8	14-7/16	15	29-5/8

¹NOTE: Dimensions are for reference only. Certified drawings should be requested for construction purposes.

Vertical Magnum Dimensions¹

Vortex

Motor Frames	AB	AG	CP			P	Motor Wt.
			3x3x14	4x4x14	6x6x14		
213P	9	20	61	65	65	11	310
215P	9	20	61	65	65	11	360
254P	10-1/2	24	66	69	69	13-1/4	380
256P	10-1/2	24	66	69	69	13-1/4	410
284P	13	26-3/4	67	71	71	14	620
286P	13	26-3/4	67	71	71	14	640
324P	14-1/4	29	71	74	74	17	885
326P	14-1/4	29	71	74	74	17	910
364P	15	31	73	76	76	18	1200
365P	15	31	73	76	76	18	1470
Assembled Unit Weight less motor — pounds			825	855	965		

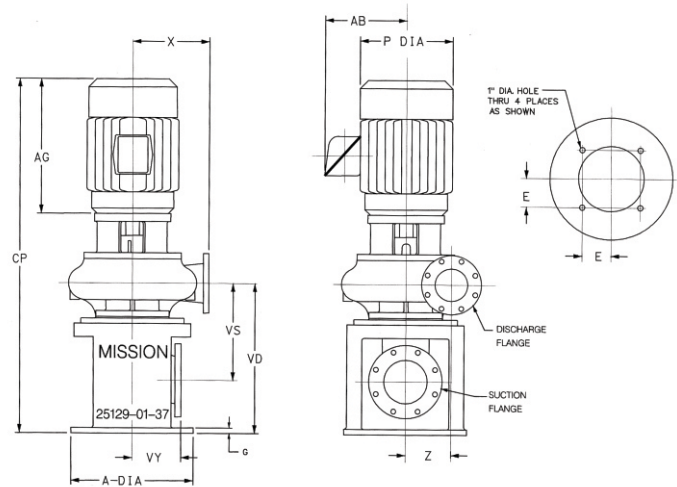

Vortex

PUMP SIZE	PIPE FLANGES * SUCTION PIPE		PIPE FLANGES * DISCHARGE PIPE		Dimensions in inches							
	SIZE	BOLT PATTERN	SIZE	BOLT PATTERN	A	E	G	VD	VS	VY	X	Z
3x3x14	3	4 Holes 3/4 D-6 B.C.	3	4 Holes 3/4 D-4-3/4 B.C.	22-1/2D	5-5/16	1	27-3/4	16-1/4	7-1/4	11	7-1/4
4x4x14	4	8 Holes 3/4 D-7-1/2 B.C.	4	8 Holes 3/4 D-7-1/2 B.C.	22-1/2D	5-5/16	1	27-3/4	16-3/16	9	11	7-1/4
6x6x14	6	8 Holes 7/8 D-9-1/2 B.C.	6	8 Holes 7/8 D-9-1/2 B.C.	22-1/2D	5-5/16	1	29-1/2	21-13/16	9-1/2	13	7-1/4

Magnum

Motor Frames	AB	AG	CP						P	Motor Wt.	
			3x2x13	4x3x13	5x4x14	6x5x11	6x5x14	8x6x11			8x6x14
213P	9	20	56	57	58	59-3/4	59-3/4	60	60	11	310
215P	9	20	56	57	58	59-3/4	59-3/4	60	60	11	360
254P	10-1/2	24	60	61	62	64	64	65	65	13-1/4	380
256P	10-1/2	24	60	61	62	64	64	65	65	13-1/4	410
284P	13	26-3/4	62-3/4	63	64-3/4	66	66	67-1/4	67-1/4	14	620
286P	13	26-3/4	62-3/4	63	64-3/4	66	66	67-1/4	67-1/4	14	640
324P	14-1/4	29	65	66	67	69	69	70	70	17	885
326P	14-1/4	29	65	66	67	69	69	70	70	17	910
364P	15	31	67	68	69	71	71	71	72	18	1200
365P	15	31	67	68	69	71	71	71	72	18	1470
Assembled unit weight less motor – pounds			800	820	855	885	925	960	990		

Magnum

PUMP SIZE	PIPE FLANGES * SUCTION PIPE		PIPE FLANGES * DISCHARGE PIPE		Dimensions in inches							
	SIZE	BOLT PATTERN	SIZE	BOLT PATTERN	A	E	G	VD	VS	VY	X	Z
3x2x13	3	4 Holes 3/4 D-6 B.C.	2	4 Holes 3/4 D-4-3/4 B.C.	22-1/2D	5-5/16	1	25-1/4	13-3/4	7-1/4	10-1/4	7
4x3x13	4	8 Holes 3/4 D-7-1/2 B.C.	3	8 Holes 3/4 D-6 B.C.	22-1/2D	5-5/16	1	25-3/4	14	9	10-1/4	6-3/4
5x4x14	5	8 Holes 7/8 D-8-1/2 B.C.	4	8 Holes 7/8 D-7-1/2 B.C.	22-1/2D	5-5/16	1	26-1/2	16-1/4	8-1/2	11	6-1/8
6x5x11	6	8 Holes 7/8 D-9-1/2 B.C.	5	8 Holes 7/8 D-8-1/2 B.C.	22-1/2D	5-5/16	1	26-1/4	18	9-1/2	11	6
6x5x14	6	8 Holes 7/8 D-9-1/2 B.C.	5	8 Holes 7/8 D-8-1/2 B.C.	22-1/2D	5-5/16	1	26-1/4	18	9-1/2	11	6
8x6x11	8	8 Holes 7/8 D-11-3/4 B.C.	6	8 Holes 7/8 D-9-1/2 B.C.	22-1/2D	5-5/16	1	26-3/4	21	14	14	8
8x6x14	8	8 Holes 7/8 D-11-3/4 B.C.	6	8 Holes 7/8 D-9-1/2 B.C.	22-1/2D	5-5/16	1	26-3/4	21	14	14	8-3/8

¹NOTE: Dimensions are for reference only. Certified drawings should be requested for construction purposes.

Magnum XP Dimensions¹

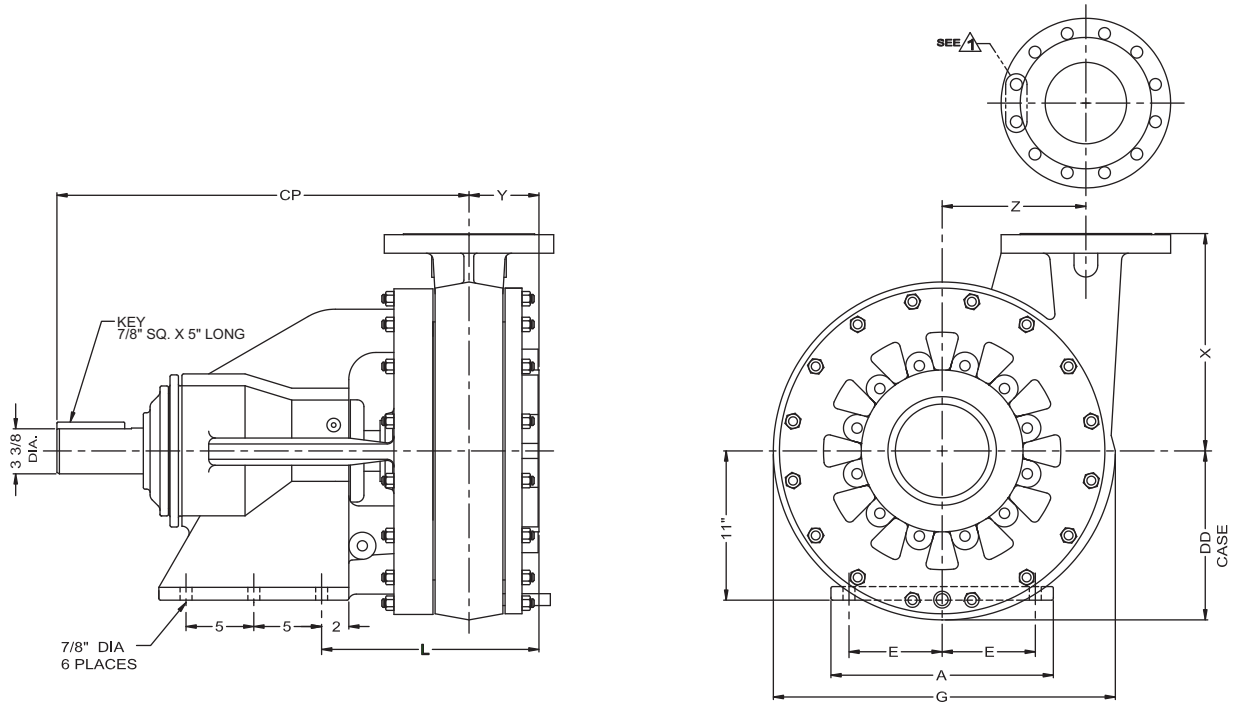

PUMP SIZE	Wt. Lbs.	PIPE FLANGES * SUCTION PIPE		PIPE FLANGES * DISCHARGE PIPE		A	E	G	L	X	Y	Z	CP	DD
		SIZE	DRILLING	SIZE	DRILLING									
8 x 6 XP	1,200	8	12 HOLES 7/8" -9UNC-2B 13" B.C.	6	12 HOLES 7/8" DIA. 10-5/8" B.C.	16-13/32	6-7/8	25-1/4	16-1/32	16	5-5/32	10-19/32	30-13/32	12-7/16
12 x 10 XP	1,950	12	12 HOLES 3/4" -10UNC-2B 17" B.C.	10	12 HOLES 1" DIA. 14-1/4" B.C.	16-13/32	6-7/8	33-5/8	18-11/16	22	6-15/16	13-1/2	31-1/2	16-13/16
14 x 12 XP	1,850	14	12 HOLES 1" -8UNC-2B 18-3/4" B.C.	12		16-13/32	6-7/8	37-3/4	18-3/8	19-7/16	6-5/8	14-9/16	31-3/16	18-13/16

* THE ABOVE DRILLING IS ANSI STANDARD 150 SERIES FLAT FACE EXCEPT THE 8 X 6 XP IS ANSI 250# (300 SERIES) RAISED FACE. ALL DISCHARGE FLANGE HOLES ARE THRU CLEARANCE HOLES EXCEPT AS NOTED.

THE DISCHARGE FLANGE DRILLING FOR THE 14 X 12 XP HAS 12 HOLES, 10 HOLES THRU 1" DIA. & 2 HOLES TAPPED 7/8 -9UNC-2B AS SHOWN, ON A 17" DIA. B.C.

¹NOTE: Dimensions are for reference only. Certified drawings should be requested for construction purposes.

MISSION™ PRODUCTS

Electric Motor Dimensions¹

- Average values of full load amperes at motor terminals
- Three phase A-C induction type squirrel cage and wound motor

Motor HP	230 Volts	460 Volts	575 Volts
1	3.60	1.80	1.40
1-1/2	5.20	2.60	2.10
2	6.80	3.40	2.70
3	9.60	4.80	3.90
5	15.20	7.60	6.10
7-1/2	22.00	11.00	9.00
10	28.00	14.00	11.00
15	42.00	21.00	17.00
20	54.00	27.00	22.00
25	68.00	34.00	27.00
30	80.00	40.00	32.00
40	104.00	52.00	41.00
50	130.00	65.00	52.00
60	154.00	77.00	62.00
75	192.00	96.00	77.00
100	240.00	120.00	96.00
125	296.00	148.00	118.00

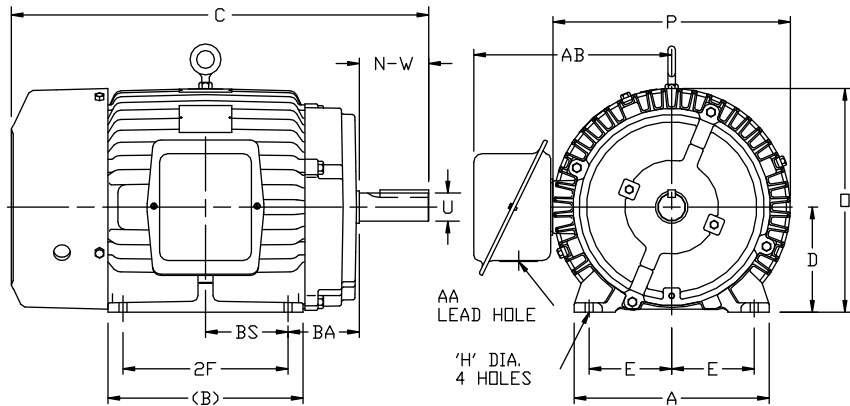

Electric Motor Approximate Dimensions

Frame	D	E	2F	H	U	N-W	AA	BA
143T	3.50	2.75	4.00	.34	.875	2.25	3/4	2.25
145T	3.50	2.75	5.00	.34	.875	2.25	3/4	2.25
182T	4.50	3.75	4.50	.41	1.125	2.75	3/4	2.75
184T	4.50	3.75	5.50	.41	1.125	2.75	3/4	2.75
213T	5.25	4.25	5.50	.41	1.375	3.38	1	3.50
215T	5.25	4.25	7.00	.41	1.375	3.38	1	3.50
254T	6.25	5.00	8.25	.53	1.625	4.00	1-1/4	4.25
256T	6.25	5.00	10.00	.53	1.625	4.00	1-1/4	4.25
284T	7.00	5.50	9.50	.53	1.875	4.62	1-1/2	4.75
284TS	7.00	5.50	9.50	.53	1.625	3.25	1-1/2	4.75
286T	7.00	5.50	11.00	.53	1.875	4.62	1-1/2	4.75
286TS	7.00	5.50	11.00	.53	1.625	3.25	1-1/2	4.75
324T	8.00	6.25	10.50	.66	2.125	5.25	2	5.25
324TS	8.00	6.25	10.50	.66	1.875	3.75	2	5.25
326T	8.00	6.25	12.00	.66	2.125	5.25	2	5.25
326TS	8.00	6.25	12.00	.66	1.875	3.75	2	5.25
364T	9.00	7.00	11.25	.66	2.375	5.88	2-1/2	5.88
364TS	9.00	7.00	11.25	.66	1.875	3.75	2-1/2	5.88
365T	9.00	7.00	12.25	.66	2.375	5.88	2-1/2	5.88
365TS	9.00	7.00	12.25	.66	1.875	3.75	2-1/2	5.88
404T	10.00	8.00	12.25	.81	2.875	7.25	3	6.62
404TS	10.00	8.00	12.25	.81	2.125	4.25	3	6.62
405T	10.00	8.00	13.75	.81	2.875	7.25	3	6.62
405TS	10.00	8.00	13.75	.81	2.125	4.25	3	6.62
444T	11.00	9.00	14.50	.81	3.375	8.50	3	7.50
444TS	11.00	9.00	14.50	.81	2.375	4.75	3	7.50
445T	11.00	9.00	16.50	.81	3.375	8.50	3	7.50
445TS	11.00	9.00	16.50	.81	2.375	4.75	3	7.50
447T	11.00	9.00	20.00	.81	3.375	8.50	3	7.50
449T	11.00	9.00	25.00	.81	3.375	8.50	3	7.50

AB, O, P and C dimensions vary by motor rating. Contact NOV for these dimensions.
Dimensions vary for each motor manufacturer. All dimensions are approximate.

¹NOTE: Dimensions are for reference only. Certified drawings should be requested for construction purposes.

Piping Recommendations

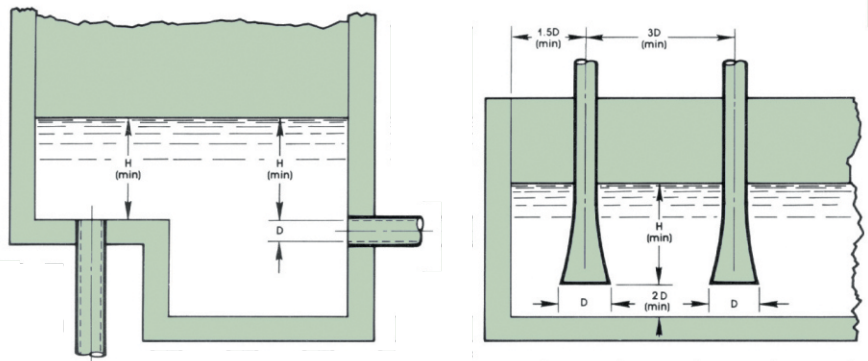
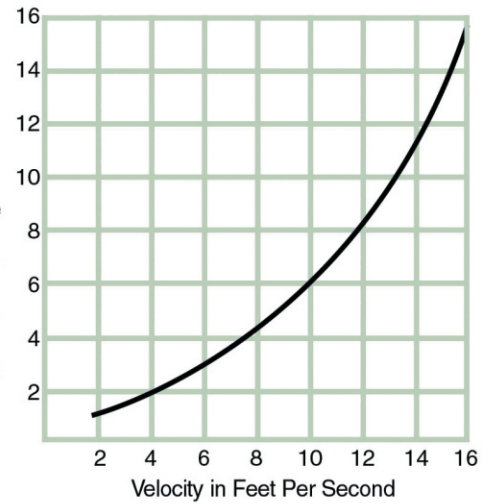

This can be used as a guide for minimum submergence and piping design.

$$\text{Velocity, feet per second} = \frac{\text{GPM} \times .4}{D^2 \text{ (inches)}}$$

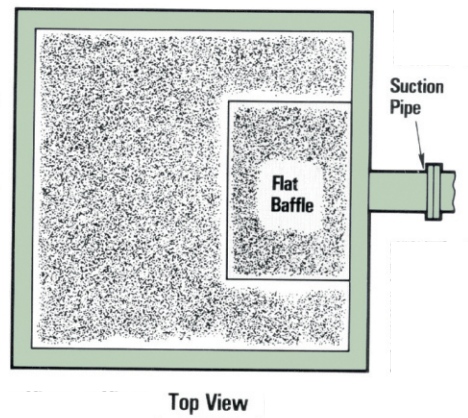
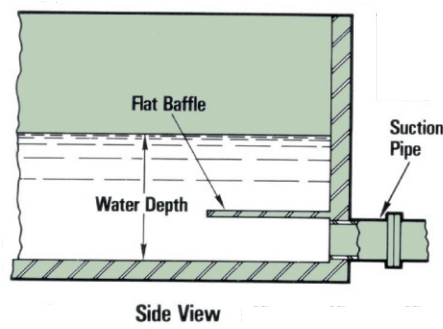

Vortex can be prevented by proper baffle arrangements.

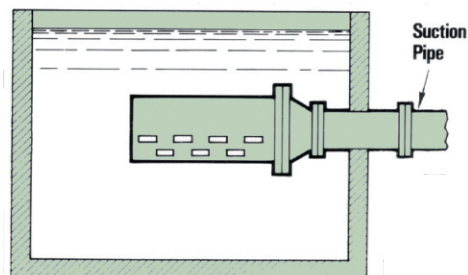

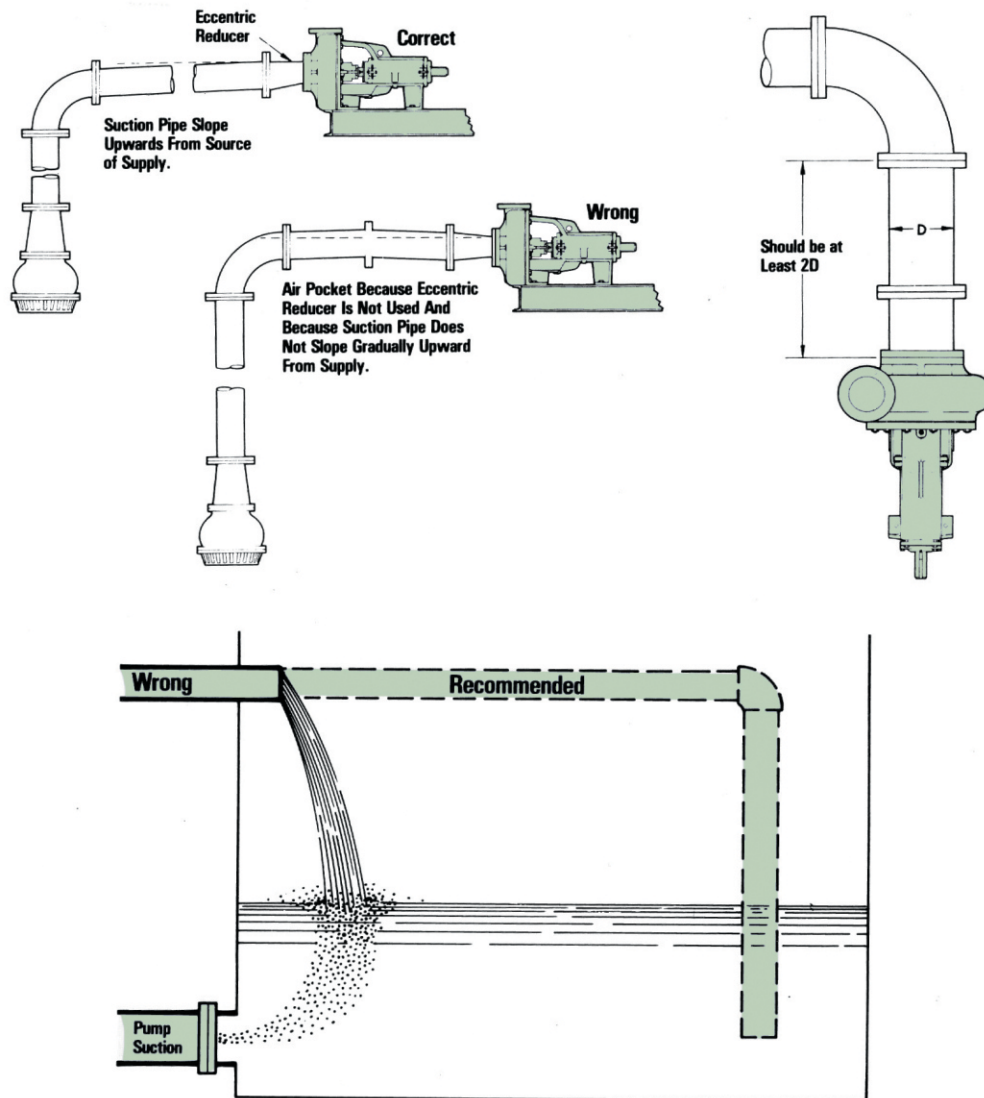

To minimize air entering the mud, return should be away from the suction and below liquid level.

Related Equipment

Associated Products Manufactured and Distributed by National Oilwell Varco



Envirohopper™
Dust Collecting



Custom Design Brake/Winch
Cooling Systems

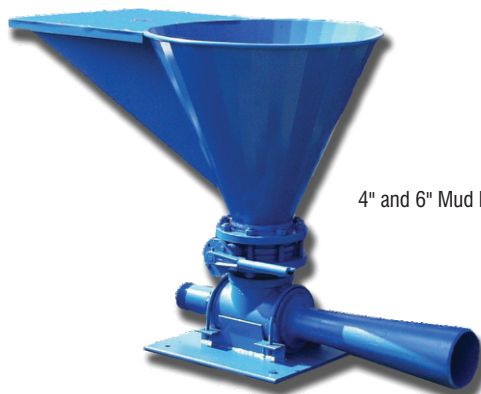

4" and 6" Mud Hoppers

Fire Suppression Systems

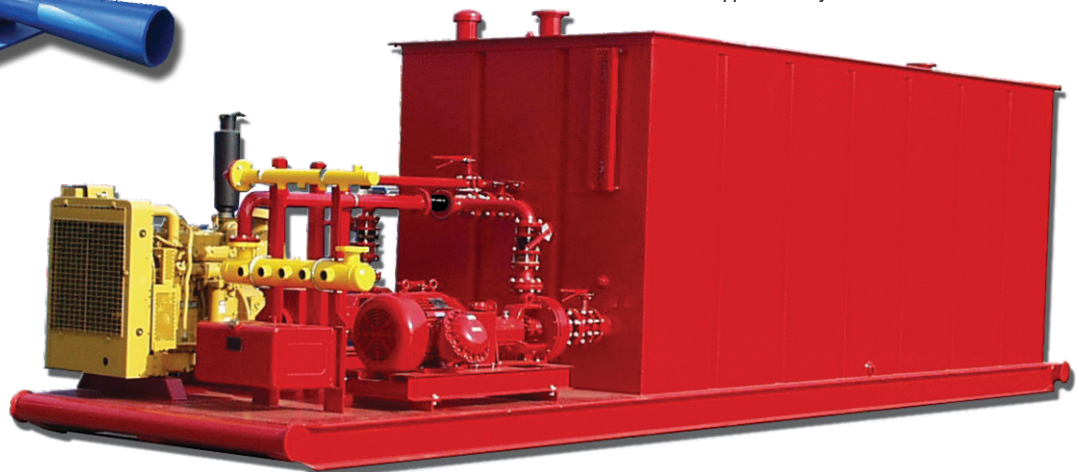

MISSION™ PRODUCTS



IEC Explosion Proof Motor Controls



Diesel Fuel Filtration Systems



Explosion Proof Electric Motors



Low Pressure Mud Guns



Potable/Sanitary Water Pressure Sets

High Pressure Washdown Systems

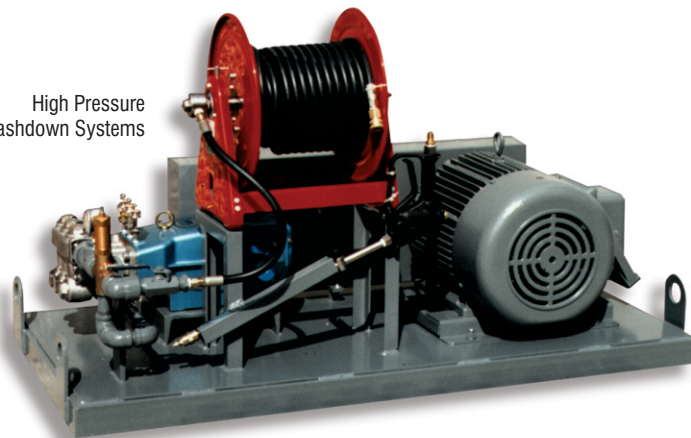

Close Coupled Centrifugal Pumps

National Oilwell Varco manufactures compact close coupled centrifugal pumps for the 1180, Magnum and 2500 Supreme pump families.

1180 Spacesaver® Centrifugal Pumps

National Oilwell Varco's line of Mission SpaceSaver Type "S" pumps have a very small footprint for applications where space is a premium. These heavy duty pumps require minimum mounting space and are close coupled eliminating couplings and coupling alignment considerations.

The SpaceSaver pump line has been proven in mud pump liner coolant service, general rig water supply, micro-tunneling mud mixing and a variety of additional applications.

Explosion proof 50 and 60 HZ motors are maintained in stock ranging from 2 to 10 HP.

Close Coupled Magnum and 2500 Supreme

National Oilwell Varco continues to provide new product design to fulfill customer needs. Close coupled Magnum and 2500 Supreme pumps utilize the same fluid end and perform identically to the standard Magnum and 2500 Supreme. The close coupled adapter bolts directly onto the motor frame and the impeller attaches to the motor shaft. This configuration eliminates the need for a large base, coupling, coupling guard and alignment considerations. This configuration reduces weight and requires the minimum cubic space of any other configuration.

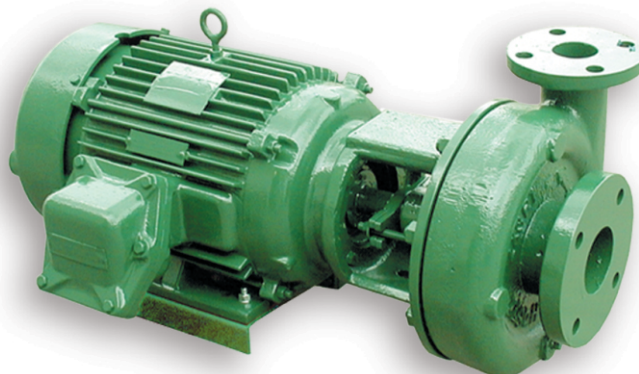

SpaceSaver Close-Coupled Type "S" Pumps
 Composite Curve: Clear liquids - Specific Gravity 1.0
 10 HP, 1800 RPM - maximum motor size

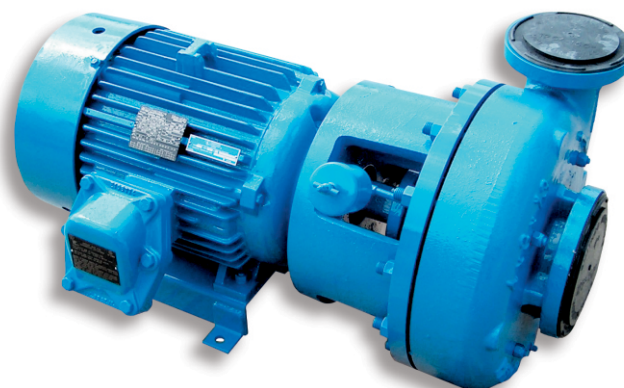
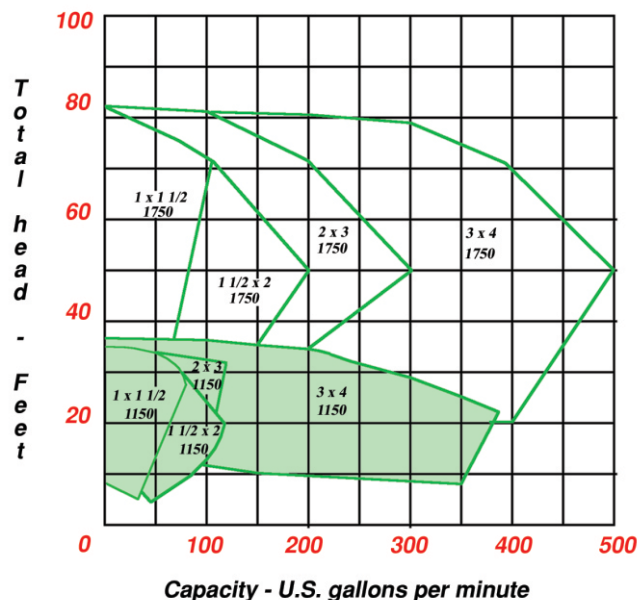

Conversion Table

Multiply	By	To Obtain
Atmospheres	1.01325	Bars
Atmospheres	33.9	Feet of water
Atmospheres	14.5	Lbs / sq. inch
Bars	0.98692	Atmospheres
Bars	1.0197	kg / cm ²
Bars	14.5	PSI
Barrels - oil	42	Gallons - oil
Barrels (42 U.S. gal) / day	0.02917	GPM
BTU	3.927 x 10 ⁴	Horsepowers - hrs.
Centimeters	0.3937	Inches
Cubic cm / sec	0.0158502	GPM
Cubic feet	0.02832	Cubic meters
Cubic feet / sec.	448.831	GPM
Cubic Inches	4.329 x 10 ⁻³	Gallons
Cubic meters / hr	4.4033	GPM
Cubic meters / min	264	GPM
Feet	0.3048	Meters
Feet of head	Specific Gravity ÷ 2.31	PSI
Feet of Water	0.0295	Atmospheres
Foot - pounds	5.050 x 10 ⁻⁷	Horsepower hrs.
Gallons	3785	Cubic centimeters
Gallons	0.1337	Cubic feet
Gallons	231	Cubic inches
Gallons	3.785	Liters
Pints	8	Gallons
Quarts	4	Gallons
Gallons - Imperial	1.20095	U.S. gallons
Gallons water	8.34	Pounds of water
Gallons / hour	0.016667	GPM
GPM	34.286	Barrels (42 U.S. gal.) / day
GPM	1.4286	Barrels (42 U.S. gal.) / hr.
GPM	0.2272	m ³ / hr
GPM	1440	Gallons / day
GPM	3.7878	Liters / min
grams/cu. cm.	1	Sp.Gr.
Horsepower hrs.	2546	B.T.U.
Horsepower hrs.	1.98 x 10 ⁶	Foot - lbs.
Kilograms / cm ²	14.223	PSI
Kilograms / sq. meter	1.422 x 10 ⁻³	PSI
Kilopascal	0.145	PSI
Kilowatts	1.341	Horsepower (U.S.)
Kilowatt hours	3414.4	B.T.U.
Liters/min	0.2642	GPM
Liters/sec	15.9	GPM
Meters	3.28	Feet
Miles	5280	Feet
Miles / hr	1.609	Kilometers / hr.
Miles / hr	0.8689	Knots
Millimeters	0.03937	Inches
PSI	0.06895	Bars
PSI	0.070307	kg / cm ²
PSI	6.895	Kilopascals

Downhole Solutions

Drilling Solutions

Engineering and Project Management Solutions

Industrial Solutions

Lifting and Handling Solutions

Production Solutions

Supply Chain Solutions

Tubular and Corrosion Control Solutions

Well Service and Completion Solutions

Corporate Headquarters

7909 Parkwood Circle Drive, Houston, Texas 77036 United States
Phone: 713 375 3700 • Toll-Free: 888 262 8645

Mailing Address: P.O. Box 4638, Houston, Texas 77210 United States

Customer Service

Houston—Windfern
11300 Windfern, Houston, Texas 77064 United States
Phone: 281 517 3100 • Toll-Free: 800 800 4110

For a complete list of NOV Mission locations visit:
<http://www.nov.com/MissionLocations>

National Oilwell Varco has produced this brochure for general information only, and it is not intended for design purposes. Although every effort has been made to maintain the accuracy and reliability of its contents, National Oilwell Varco in no way assumes responsibility for liability for any loss, damage or injury resulting from the use of information and data herein. All applications for the material described are at the user's risk and are the user's responsibility.
All brands listed are trademarks of National Oilwell Varco.



One Company . . . Unlimited Solutions

mission@nov.com

www.nov.com/mission