

Hydra-Cell[®]

Seal-less Pumps



Hydra-Cell F/M/D/H Series Seal-less Pumps



Hydra-Cell T & Q Series Seal-less Pumps



Hydra-Cell "Pulse-free" Metering Pumps



Hydra-Cell® Seal-less Pumps



Contents	Page
Design Advantages	4
Application Versatility	6
Markets & Industries Served	7
Primary Pumping Applications	8
Fluid Handling Capability	9
Principles of Operation	
Wobble Plate Design	10
Crank-shaft Design	11
Diaphragm Protection (DPC Technology)	12
Certifications, Patents & Industry Recognition	13
Design & Manufacturing Standards	14
Mass Customization	15
Materials of Construction	16
Hydra-Cell F/M/D/H Series Pumps	
Selection Guide	18
Flow Capacities & Pressure Ratings	19
Models, Specifications & How to Order	20
C Series Valves	
Selection Guide	82
Design Advantages	83
Models, Specifications & How to Order	84
Accessories	92
Hydra-Cell T & Q Series Pumps	
Selection Guide	122
Flow Capacities & Pressure Ratings	123
Design Advantages	124
Models, Specifications & How to Order	126
Hydra-Cell Metering Solutions Pumps	
Selection Guide	162
Flow Capacities & Pressure Ratings	163
Design Advantages	164
API 675 Performance Standards	166
Models, Specifications & How to Order	168
P Series & MT8 Metering Accessories	185
Bare Shaft Pumps for Metering	186
S Series Solenoid Metering Pumps	187
Frequently Asked Questions	188
Design Considerations	189
Installation Guidelines	190
Materials Reference	192
Glossary of Terms	194
Additional Wanner Engineering Pumps	196
Limited Warranty	198
Application Worksheet	199
Worldwide Sales & Service	201

“If the owner of a plant wants cost-effective pumps...he will buy pumps with the lowest Life Cycle Cost. Hydra-Cell is simple in construction, less elaborate in design and physically smaller for equivalent flow/pressure performance. These differences can substantially affect both purchase and operating costs.”

Dr. Ing Friedrich Wilhelm Hennecke
Chemical Engineering World



Due to the Wanner Engineering Continuous Improvement Program, specifications and other data in this catalog are subject to change.

Hydra-Cell® is a registered trademark of Wanner Engineering, Inc.

Kel-Cell® is a registered trademark of Wanner Engineering, Inc.

Control Freak™ is a trademark of Wanner Engineering, Inc.

Hydra-Cell® Seal-less Design Advantages

Hydra-Cell positive displacement pumps feature a seal-less pumping chamber so there are no mechanical seals, packing or cups to leak or replace. The seal-less design and check valves enable Hydra-Cell to handle abrasives and particulates that would damage other types of pumps. In addition, Hydra-Cell can run dry indefinitely without damage to the pump. The multiple-diaphragm design of Hydra-Cell provides virtually pulse-less, linear flow without the need for expensive pulsation dampeners.

Economical

- Can save approximately 30% to 50% on initial costs because Hydra-Cell uses lower horsepower motors to achieve the same flow rates and pressures as other pumps.
- Compact design with smaller footprint provides more efficient use of floor space.
- Operates at 85-90% energy efficiency to reduce operating costs.
- Seal-less design reduces maintenance and repair expenditures and minimizes the cost of spare parts compared to other types of pumps.

Versatile

- Variety of styles and models to pump a wide range of flow capacities and pressure ratings.
- Hydraulically-balanced diaphragms can pump low-to-high-viscosity liquids throughout the entire pressure range of the pump.
- Available in a variety of construction materials to meet a wide range of applications and ensure optimum pumping life even when handling aggressive fluids.
- Can be fitted with SAE, ANSI or DIN flanges as well as IEC or NEMA motor mounts.
- Can be provided with ATEX certification or other certification to adapt to specific applications or meet international standards.
- Design allows for easy interchangeability of pump head materials and can accommodate mixing different materials with one pump head.





Capable

- Tolerates abrasive solids and particulate matter up to 800 microns (depending on pump model) and 9 hardness (out of 10) on the Mohs scale without the need for fine filtration.
- Multiple diaphragms provide virtually pulse-less flow that exceeds API 675 standards for accuracy, linearity, and repeatability.
- Low-shear pumping action ensures integrity of long-chain structures.

Reliable

- Can run dry indefinitely without damage to the pump.
- Robust design tolerates non-ideal operating conditions.
- No mechanical seals, packing or cups to leak or replace.
- Can operate up to 6,000 hours between lubricating oil changes.
- Can pump acids, slurries, and liquids containing up to 40% of non-dissolved (suspended) solids.
- Does not rely on the fluid being pumped for lubrication.
- No tight tolerances susceptible to corrosion or solid particles.

Environmental

- Liquids are 100% sealed from the atmosphere.
- No leak path for toxic vapors or harmful gasses.
- No dynamic seals to leak any Volatile Organic Compounds (VOC).
- Lower energy costs to operate pump.



Hydra-Cell® Application Versatility

Hydra-Cell pumps operate reliably and efficiently in commercial, institutional, industrial, and municipal facilities throughout the world. The breadth of the product line offers a wide range of flow capacities and pressure ratings to meet

many different requirements. The further capability to provide precise metering and dosing is ideal for many specialized applications. Hydra-Cell pumps can also be fitted with SAE, ANSI, DIN, or other flange connections.

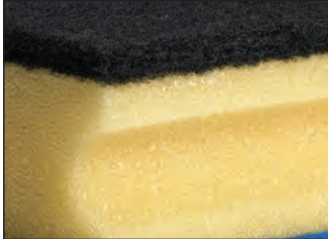
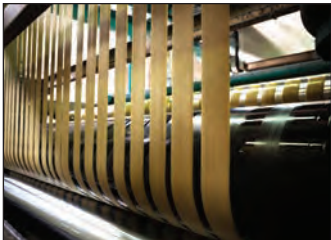

Markets and Industries Served

- Agricultural
- Automotive
- Biodiesel
- Biotechnical
- Car/Vehicle Washing
- Ceramics
- Chemical & Petrochemical
- Chip Board Manufacturing
- Cleaning & Washing
- Construction
- Electronics
- Emissions & Environmental Control
- Energy & Power Generation
- Flue Gas Emission Control
- Food & Beverage Processing
- General Industrial & Manufacturing
- Glass & Clay
- Landscaping & Lawn Care
- Machine Tool Coolant
- Marine
- Mining, Quarrying & Tunneling
- Offshore Drilling & Processing
- Oil, Gas & Petrochemical
- Paints, Coatings, Sealants & Adhesives
- Personal Care
- Pharmaceutical
- Polyurethane
- Propellant Packaging
- Pulp & Paper
- Reverse Osmosis & Filtration
- Rubber & Plastic
- Spray Drying
- Steam Generation
- Steel
- Textiles
- Tote, Tank & Barrel Washing
- Water & Wastewater Treatment



Hydra-Cell® Primary Pumping Applications

- Blending
- Coating
- Dosing
- Filtering
- Metering
- Spraying
- Cleaning
- Cooling
- Filling
- Injecting
- Mixing
- Transferring

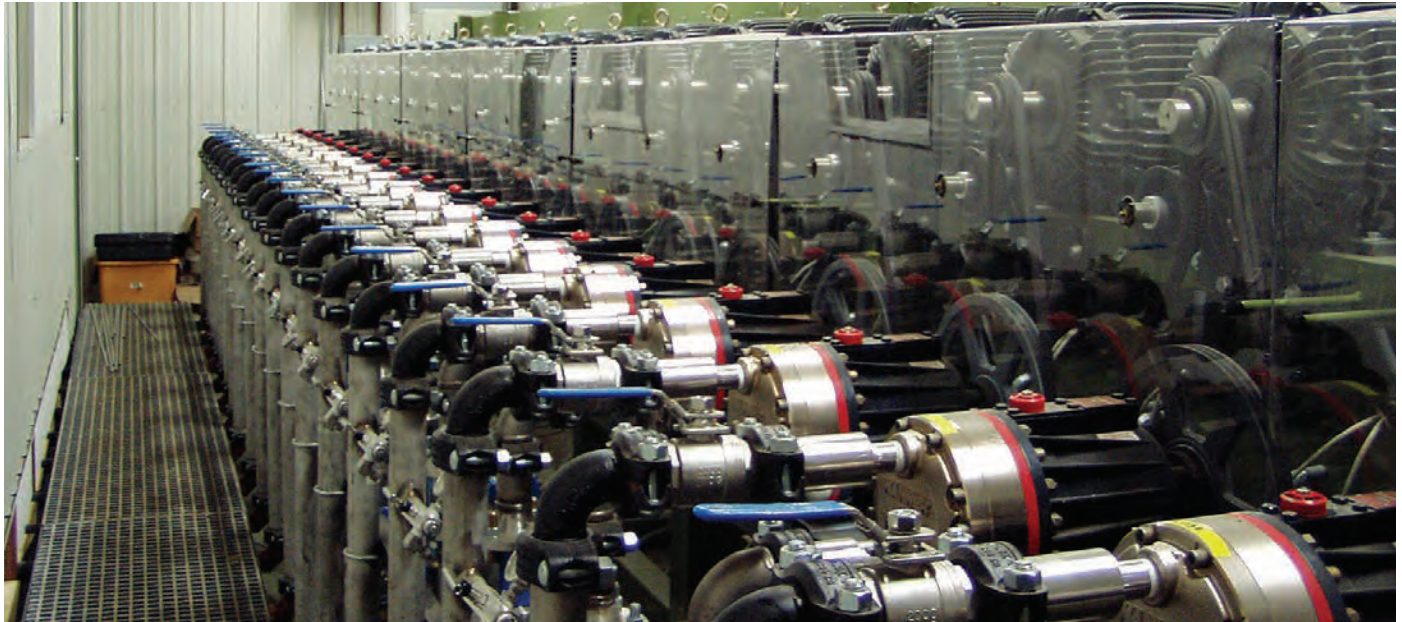

Hydra-Cell pumping shear-sensitive polymers for enhanced oil recovery.

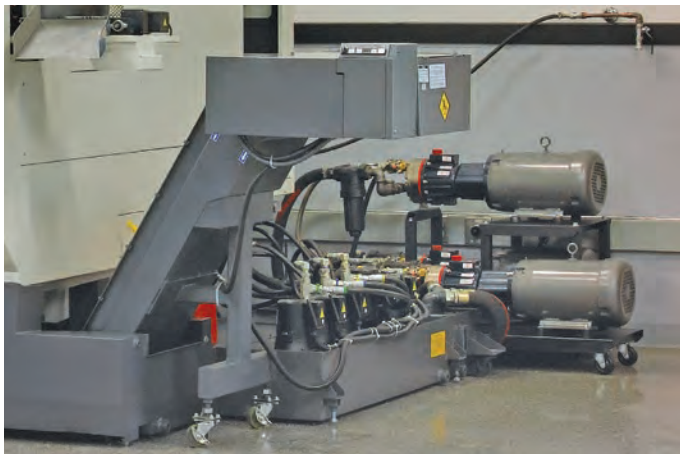

Hydra-Cell pumps deliver high-pressure, controlled flow of machine tool coolant without the need for fine filtration.

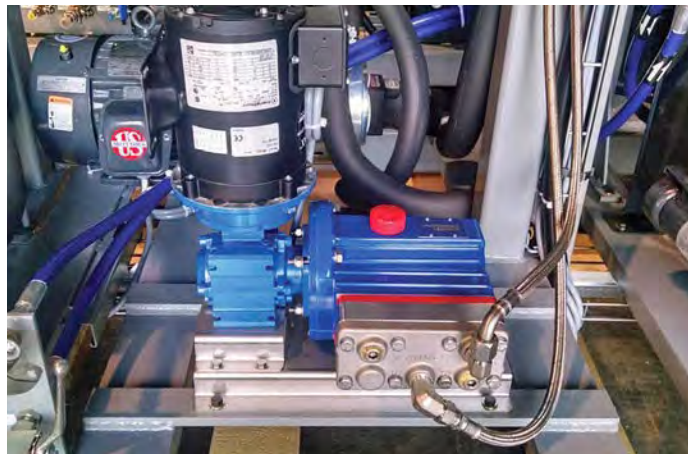

A P200 replaced an external gear pump to deliver a catalyst for polyurethane foam production and doubled volumetric efficiency.

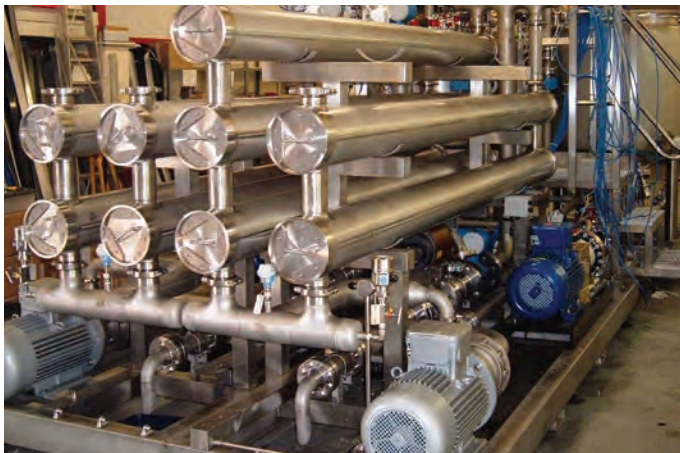

Pumping for waste stream reduction and salt solution concentration at a pharmaceutical chemical plant.

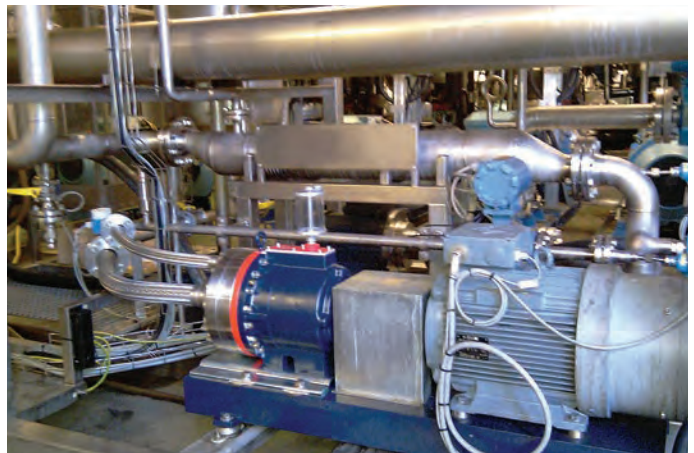

Hydra-Cell pumps used for ultra-filtration by a food additive manufacturer.

Hydra-Cell® Fluid Handling Capability

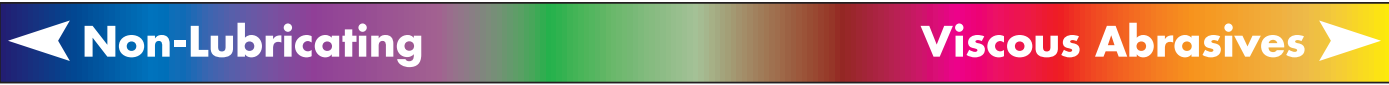

Propane/ Butane Freon Ammonia Polymers Fuels/ Additives D.I. Water Glycols Chlorine Acids/ Caustics Glues/ Adhesives Inks/ Paints Resins Slurries

Handles Abrasives and Low-to-High Viscosity Fluids

From drinking water to highly viscous cutting fluids, Hydra-Cell pumps handle the full spectrum of process fluids while maintaining high-efficiency operation. This includes non-

lubricating fluids as well as difficult fluids with abrasives that can damage or destroy other types of pumps. This makes Hydra-Cell an ideal choice in a wide range of industries and when serving multiple applications in one facility.

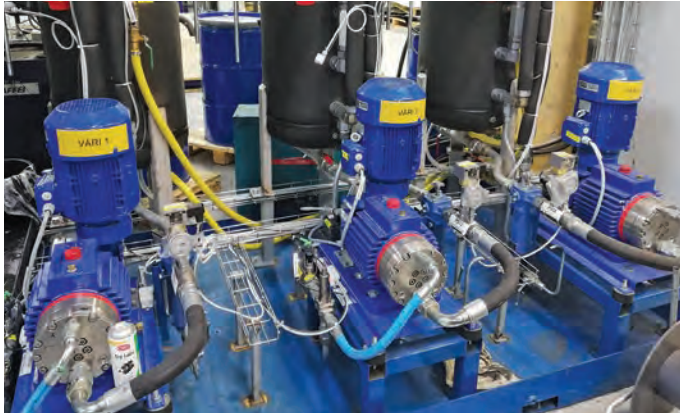

Three P500 models replaced six piston pumps for spraying an adhesive colorant and substantially reduced maintenance costs.



Several operational features of Hydra-Cell pumps are showcased when processing volatile crude oil.



Pumping ceramic slurry in a spray drying application can be a problem for other types of pumps, but not Hydra-Cell.



Hydra-Cell pumping ethanol-based fluid for making jet fuel.



Chemical boiler feed at a power plant. Four MT8 pumps running off two gearboxes and two motors shows its duplexing capability.

Hydra-Cell® Principles of Operation

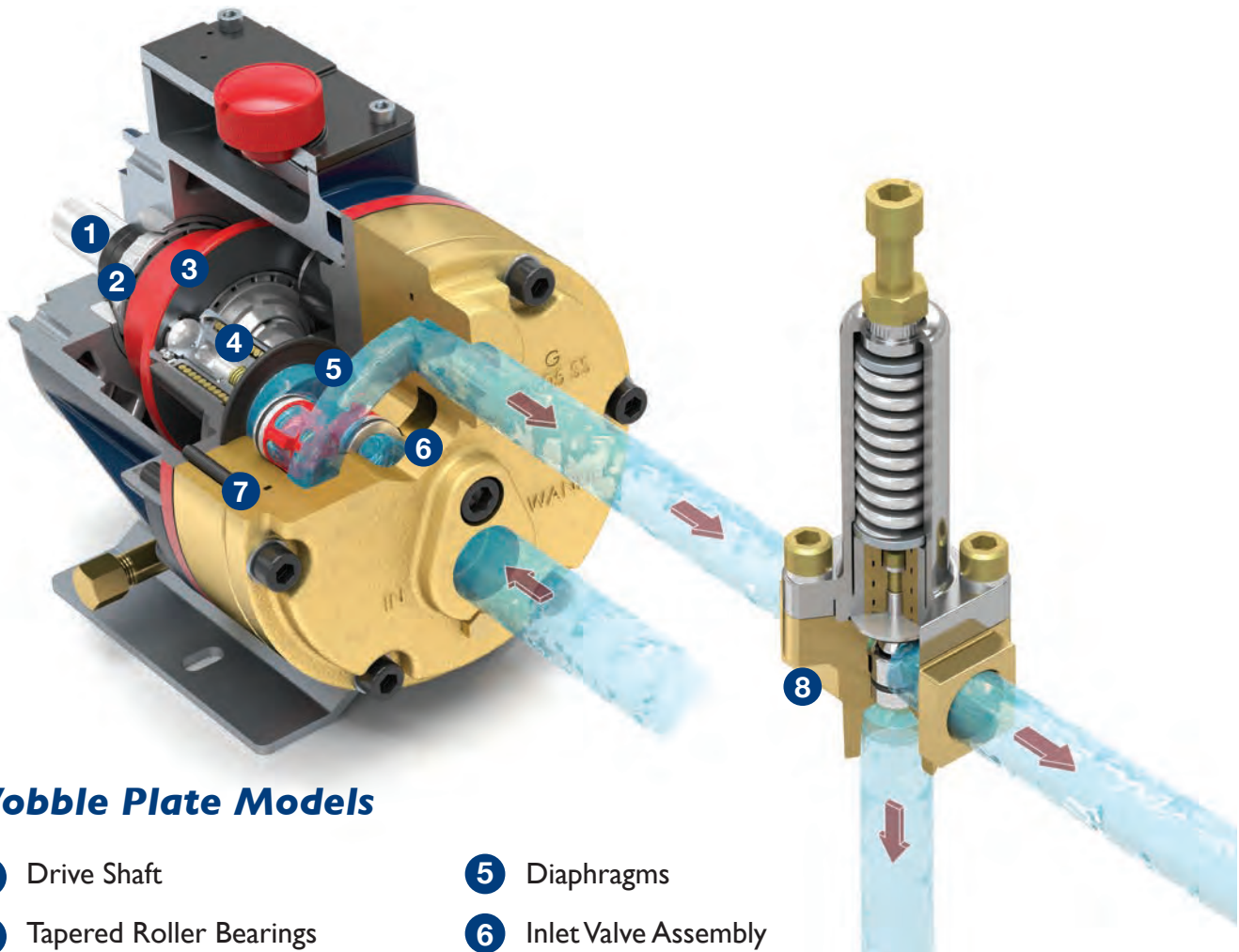

Wobble Plate Models

- | | |
|--------------------------------|---------------------------------|
| 1 Drive Shaft | 5 Diaphragms |
| 2 Tapered Roller Bearings | 6 Inlet Valve Assembly |
| 3 Fixed-angle Cam/Wobble Plate | 7 Discharge Valve Assembly |
| 4 Hydraulic Cells (Patented) | 8 C62 Pressure Regulating Valve |

Reliable, Efficient Pumping Action

The drive shaft (1) is rigidly held in the pump housing by a large tapered roller bearing (2) at the rear of the shaft and a smaller bearing at the front of the shaft. Set between another pair of large bearings is a fixed-angle cam or wobble plate (3). As the drive shaft turns, the wobble plate nutates, oscillating forward and back (converting axial motion into linear motion). The complete pumping mechanism is submerged in a lubricating oil bath.

The hydraulic cell (4) is moved sequentially by the wobble plate and filled with oil on its rearward stroke. A ball check valve in the bottom of the piston ensures that the cell remains full of oil on its forward stroke.

The oil held in the Hydra-Cell balances the back side of the diaphragms (5) and causes the diaphragms to flex forward and back as the wobble plate moves. This provides the pumping action.

To provide long trouble-free diaphragm life, Hydra-Cell hydraulically balances the diaphragm over the complete

pressure range of the pump. The diaphragm faces only a 3 psi (0.21 bar) pressure differential regardless of the pressure at which fluid is being delivered – up to 2500 psi (172 bar) for original Hydra-Cell models, 5000 psi (345 bar) for the T & Q Series, and 3500 psi (241 bar) for Hydra-Cell Metering Solutions pumps.

Hydra-Cell wobble plate pumps can have up to five diaphragms, and each diaphragm has its own pumping chamber that contains an inlet and discharge self-aligning horizontal disk check valve assembly (6). As the diaphragms move back, fluid enters the pump through a common inlet and passes through one of the inlet check valves. On the forward stroke, the diaphragm forces the fluid out the discharge check valve (7) and through the manifold common outlet. Equally spaced from one another, the diaphragms operate sequentially to provide consistent, low-pulse flow.

A Hydra-Cell C62 pressure regulating valve (8) is typically installed on the discharge side of the pump to regulate the pressure of downstream process or equipment.

Hydra-Cell® Principles of Operation

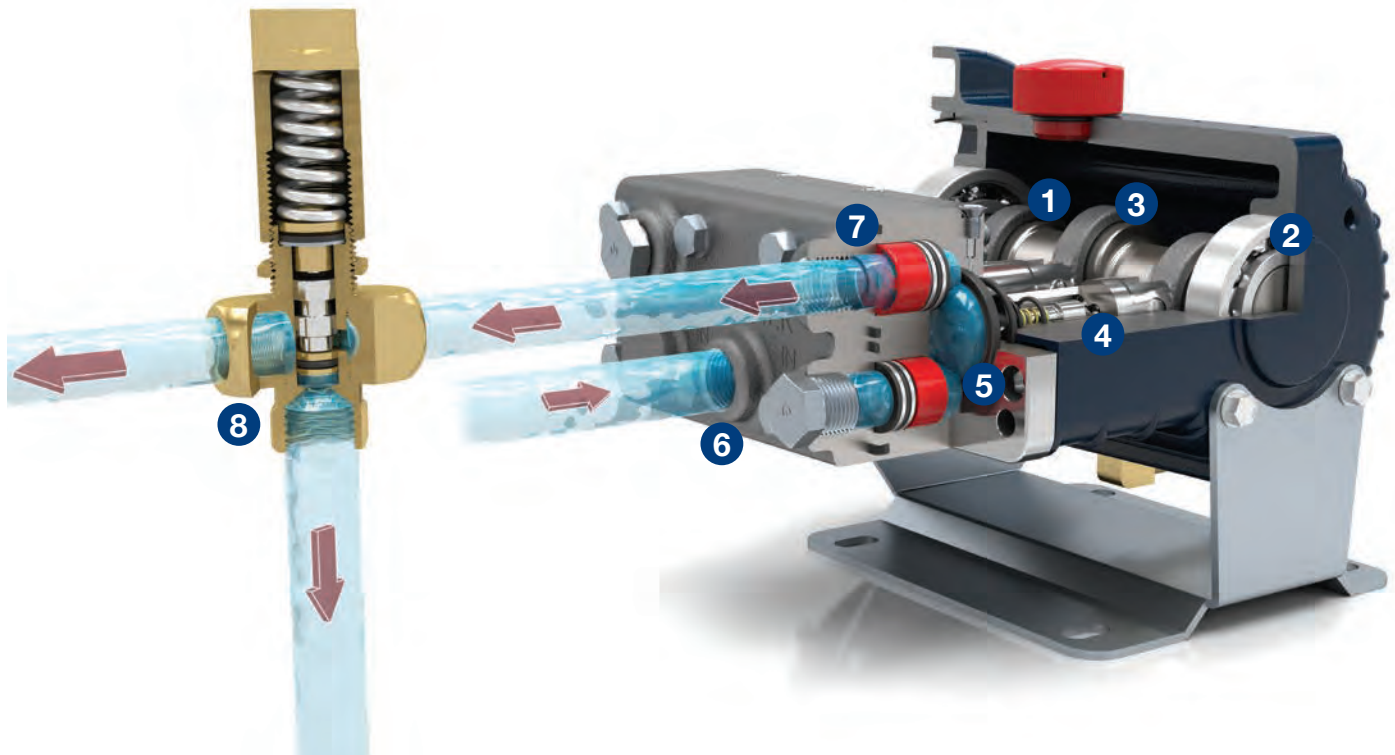

Crank-shaft Models

- | | |
|------------------------------|---|
| 1 Drive Shaft | 5 Diaphragms |
| 2 Precision Ball Bearings | 6 Inlet Valve Assembly |
| 3 Connecting Rods | 7 Discharge Valve Assembly |
| 4 Hydraulic Cells (Patented) | 8 C46 Pressure Regulating Valve (In-line) |

Reliable, Efficient Pumping Action

The drive shaft (1) is supported in position by two precision ball bearings (2) positioned at either end of the shaft. Located between these bearings are either one or three cam shaft lobes with connecting rods (3) that are hardened, precision ground, and polished. Maintaining a high level of quality on the cam lobes and connecting rod surfaces ensures proper lubrication and reduced operating temperatures in the hydraulic end of the pump.

As the drive shaft turns, each cam actuates the attached connecting rod that is pinned into position at the end of each hydraulic piston. This action moves the piston forward and backward, converting the axial motion into linear pumping motion. The complete pumping mechanism is submerged in a lubricating oil bath.

Each piston contains a patented hydraulic cell (4) that is moved sequentially by the crank-shaft. The innovative and proprietary Hydra-Cell maintains the precise balance of oil behind the diaphragm (5) regardless of the operating conditions of the pump. The oil in Hydra-Cell is pressurized on the forward stroke of the piston causing the diaphragm to flex, which drives

the pumping action. The oil held in the Hydra-Cell balances the diaphragm against the fluid being pumped, maintaining no more than a 3 psi (0.21 bar) pressure differential regardless of the pressure at which fluid is being delivered – up to 2500 psi (172 bar) for original Hydra-Cell models, 5000 psi (345 bar) for the T & Q Series, and 3500 psi (241 bar) for Hydra-Cell Metering Solutions pumps.

Hydra-Cell crank-shaft pumps can have up to three diaphragms, and each diaphragm has its own pumping chamber that contains an inlet and discharge self-aligning horizontal disk check valve assembly (6). As the diaphragms move back, fluid enters the pump through a common inlet and passes through one of the inlet check valves. On the forward stroke, the diaphragm forces the fluid out of the discharge check valve (7) and through the manifold common outlet. Equally spaced from one another, the diaphragms operate sequentially to provide consistent, low-pulse flow.

A Hydra-Cell C46 pressure regulating valve (8) is typically installed on the discharge side of the pump to regulate the pressure of downstream process or equipment.

Hydra-Cell® Diaphragm Protection

Advanced Diaphragm Position Control (ADPC) Technology

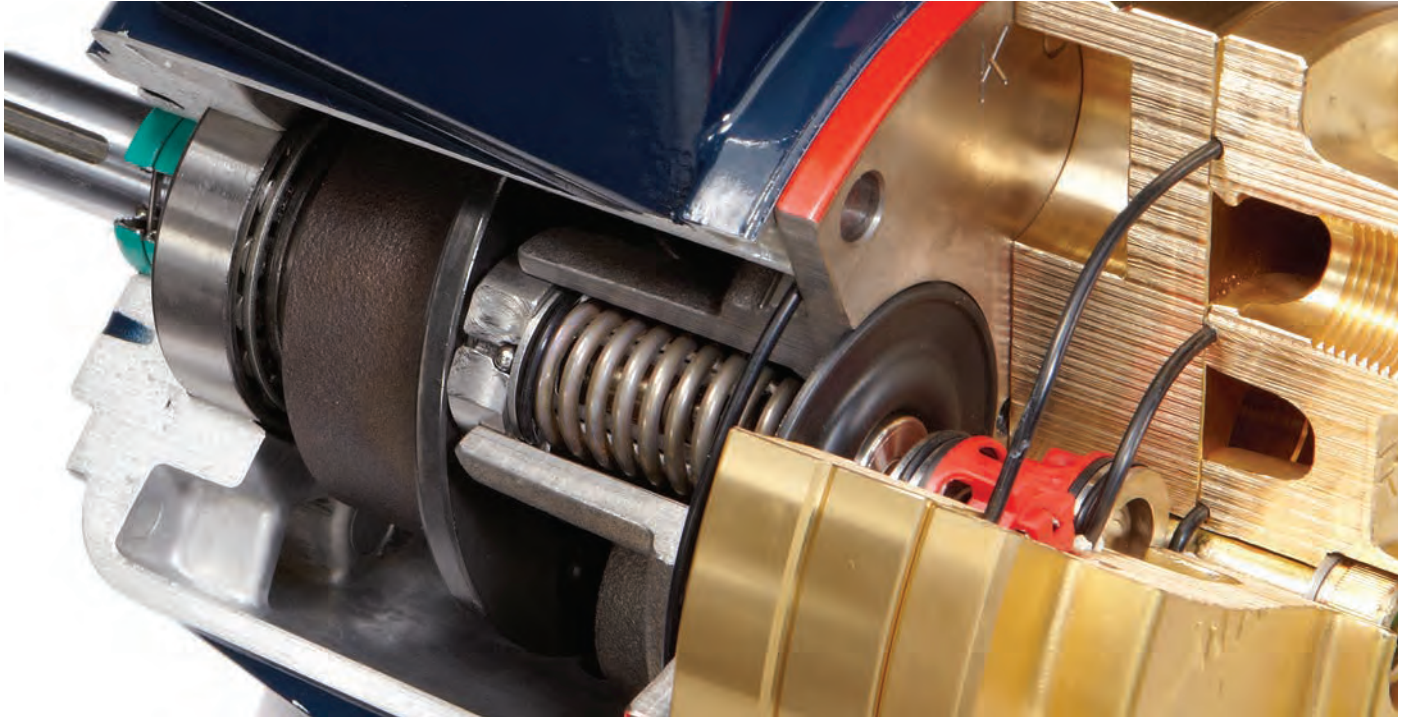

All Hydra-Cell pumps feature a diaphragm protection system to safeguard the diaphragms against abnormal or adverse conditions. Most Hydra-Cell models feature our patented Kel-Cell® or new Advanced Diaphragm Position Control (ADPC) technology. Others use an exclusive underfill/overflow valve system. They are designed to protect against:

- Partially or completely blocked inlet pipe or inlet filter.
- Partly or completely closed inlet shut-off valve.
- Inadequate liquid supply.
- Excessively viscous fluids.
- Inadequate discharge pressure.
- Other conditions that result in excessive vacuum formed at the inlet of the pump.

These conditions can result from system problems, poor system design, faulty installation, an unplanned operational incident, or other situations that would cause the diaphragms to operate out of hydraulic balance and ultimately deform and rupture.

Kel-Cell and ADPC positioning systems stabilize the diaphragms in all such conditions and virtually eliminate the possibility of an incidental diaphragm failure caused by adverse conditions.

The underfill/overflow valve ensures optimum actuating oil on every stroke for continuous accuracy and protection of the pump and diaphragms.



Diaphragm positioning systems protect diaphragms on most Hydra-Cell models.

Hydra-Cell Metering Solutions model MT8 is one of the Hydra-Cell pumps to feature the underfill/overflow valve system.

Hydra-Cell® Proven Technology

Certifications



ISO 9001: 2015
CERTIFIED



The Wanner Engineering Quality Management System is certified to the ISO 9001 standard by TÜV Rheinland, an independent third-party registrar. The Quality Management System, which includes the company's Quality Policy and Quality Objectives, is reviewed annually by top management to ensure effective continuous improvement practices and to provide the resources necessary to meet customer requirements with optimal customer satisfaction.



The CE mark identifies compliance of Hydra-Cell pumps with the European Union's Essential Health and Safety Requirements (EHSR). This includes the Safety of Machinery Directive 98/37/EC, one of a series of mandatory standards adopted by EU member countries. Our compliance allows Wanner to self-certify and place the CE marking on Hydra-Cell pumps.

Patents Held by Wanner Engineering

Wanner Engineering holds more than one dozen USA patents related to its seal-less pumping technology. For a complete list of patents, visit our website.

www.Hydra-Cell.com/patents

Industry Memberships



**American Chemistry Council
Center for Polyurethanes Industry**

Associate member



Wanner and Hydra-Cell Awards



Every year, the Minneapolis Star Tribune recognizes the most progressive companies in Minnesota based on employee opinions measuring engagement, organizational health, and satisfaction. For the second consecutive year, Wanner Engineering has earned this recognition.

Presented by the Institution of Chemical Engineers, the IChemE Awards recognize innovation and excellence in making outstanding contributions to safety, the environment, and sustainable development in the chemical and bioprocess industries. Introduced in 2006, Hydra-Cell Metering Solutions pumps earned Honourable Mention in the category for new products.



Hydra-Cell T100 Series pumps received a "Spotlight on New Technology" award at the 2010 Offshore Technology Conference in recognition of the latest and most advanced technologies that are leading the industry into the future. Winners are selected for being new, innovative, proven (in application or prototype), of broad interest to the industry, and of significant impact, including environmental benefits.



Selected by the editors and advisory board of *Pumps & Systems* magazine, the Hydra-Cell T100 High Pressure model earned recognition as a finalist in the publisher's 2010 "Product Innovation" awards. As noted by the trade journal, Hydra-Cell T100 has a patented valve system that maintains the correct volume of hydraulic fluid in the pumping chamber behind the diaphragm.



Hydra-Cell® Design and Manufacturing Standards



Hydra-Cell seal-less pumps are designed, built, and tested in the Wanner Engineering 80,000 square foot facility in Minneapolis, Minnesota. We have more than 40 years of experience serving manufacturers, processors, and commercial or institutional organizations, including many major global companies.



**ISO 9001: 2015
CERTIFIED**



Hydra-Cell pumps are performance-proved for efficiently pumping the widest range of corrosive, high-temperature, abrasive, viscous, non-lubricating, and recycled fluids, as well as liquids containing solids. Every pump is assembled with the proper materials of construction to meet the application.

Our capability is the result of a strategic emphasis on adopting sound management principles throughout the plant combined with attention to detail for every task and procedure.



Continuous Improvement

- High-precision machining equipment and lean production practices throughout an extensively automated manufacturing facility.
- All pumps are designed, built, and tested in the USA.
- Design engineering services available for assistance with your application.
- Extensive inventory and reliable supply chain.
- Stringent quality control systems for component-to-component and unit-to-unit quality and consistency.
- Every pump is tested (15-minute to 2-hour run cycles) for full flow at rated pressure, temperature, noise, and vibration.

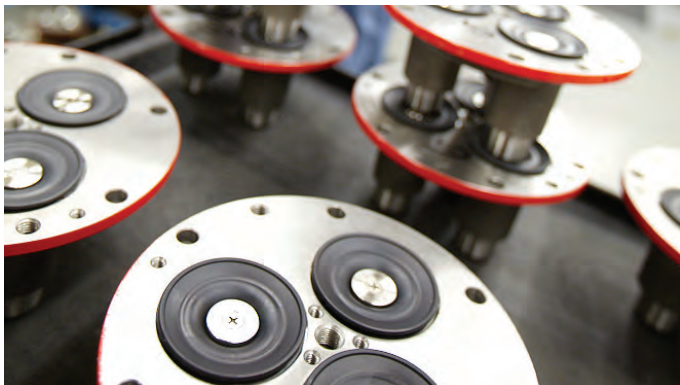

Mass Customization Means Maximum Flexibility

Every order is a priority at Wanner Engineering. Every pump is built to order. Our “Mass Customization” philosophy leverages the modular design of Hydra-Cell with sophisticated operational methods to:

1. Provide you with the properly configured pump for your process application;
2. At a competitive price;
3. Delivered with minimal lead time.

We can help you match your flow/pressure requirements to select the best model and materials of construction based on your process fluid and industry application. We maintain optimum inventory levels of parts and components that translate into cost efficiencies and faster turnaround time for customers.

An expert staff and attentive customer service practices enable us to achieve the goals of providing the Hydra-Cell pump engineered and configured to your specifications.

- A wide selection of metallic and non-metallic pump head materials plus diaphragm, valve and o-ring materials enable easy configuration to meet your specific needs from in-stock components.
- Base plates, couplings and coupling guards are available in several inline and parallel mounting configurations to suit your facility and operating environment.
- Custom pump head and body castings are available, as well as matching OEM paint and private labeling.
- Comprehensive assortment of accessories include regulator valves, oil coolers and filtration, oil level monitoring, couplings, guards, connectors, and tool kits.
- Options to enhance performance such as gear boxes, controllers, pulsation dampeners, and an assortment of drives.



Hydra-Cell® Materials of Construction

As part of our “Mass Customization” philosophy, every Hydra-Cell pump is built with manifolds, elastomeric materials, and valve assemblies using construction materials specified by the customer. Hydra-Cell distributors and factory representatives are readily available to assist customers in selecting the materials best suited to the process application. (The range of material choices depends on each pump model – for example, models designed to operate at higher pressures are available with metallic pump heads only.)

Manifolds



Manifolds for Hydra-Cell pumps are available in a variety of materials to suit your process application. They are easy to replace and interchangeable to accommodate different fluids processed by the same pump. Special manifolds with a 2:1 dosing ratio are also available. (Consult factory.)

Metallic Pump Heads

Metallic pump heads can handle higher operating pressures. Hastelloy C or Stainless Steel is also selected for corrosion resistance and other properties.

- Brass
- Manganese Bronze
- Nickel Aluminum Bronze (NAB)
- Cast Iron (Nickel-plated)
- Ductile Iron (Nickel-plated)
- Hastelloy C
- Duplex Alloy 2205 Stainless Steel
- 304 Stainless Steel
- 316L Stainless Steel

Non-metallic Pump Heads

Non-metallic pump heads are often used when a corrosive or aggressive fluid is being processed at lower pressures.

- Polypropylene
- PVDF
- PVC

Diaphragms and O-rings



Diaphragms and corresponding o-rings are available in several elastomeric materials. For diaphragm start-up temperatures and material markings, see page 193.

- Aflas diaphragm/o-ring (T & Q Series)
- Aflas diaphragm/PTFE o-ring
- Buna-N
- EPDM (requires EPDM-compatible oil)
- Neoprene
- PTFE
- FKM



Valve Materials



Hydra-Cell valve assemblies (seats, valves, springs, and retainers) are available in a variety of materials to suit your process application. For reference to identify metallic materials used for valves and valve seats, see page 192. For fluid temperature ranges of valve spring retainers, and reference to identify non-metallic spring retainers, see page 193.

Valve Seats

- Ceramic
- Hastelloy C
- Nitronic 50*
- Tungsten Carbide
- 17-4 Stainless Steel
- 316L Stainless Steel

Valves

- Ceramic
- Hastelloy C
- Nitronic 50*
- Tungsten Carbide
- 17-4 Stainless Steel

Valve Springs

- Manganese Bronze
- Nickel Aluminum Bronze (NAB)
- Elgiloy*
- Hastelloy C
- 17-7 Stainless Steel
- 316L Stainless Steel

Valve Spring Retainers

- Celcon*
- Hastelloy C
- Nylon
- PVDF
- Polypropylene
- 17-7 Stainless Steel
- 316 Stainless Steel

* For properties and characteristics of these materials to aid in pump selection, see page 193.

Registered trademarks of materials:

Aflas®	Asahi Glass Co., Ltd.
Buna®-N (Nitrile)	E.I. Du Pont de Nemours and Company, Inc.
Celcon®	Celanese Company
Elgiloy®	Elgiloy Limited Partnership
Hastelloy® C	Haynes International, Inc.
Kynar® (PVDF)	Arkema, Inc.
Mesamoll®	Lanxess Deutschland GmbH
Neoprene®	E.I. Du Pont de Nemours and Company, Inc.
Nitronic® 50	AK Steel Corporation
Teflon® (PTFE)	E.I. Du Pont de Nemours and Company, Inc.
Viton® (FKM)	DuPont Performance Elastomers, LLC
Zytel® (Nylon)	E.I. Du Pont de Nemours and Company, Inc.

Hydra-Cell® F/M/D/H Series Seal-less Pumps Selection



F20
Page 20



M03 & Mono-Block
Pages 26 & 32



D04
Page 38



D10
Page 44



D12
Page 50

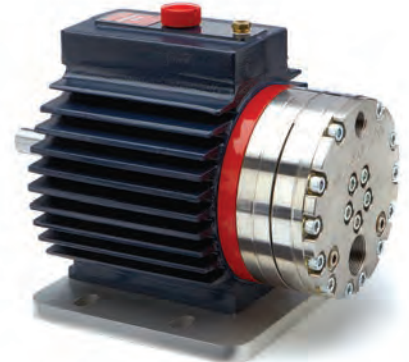

D15 & D17
Page 58



H25
Page 64



D35
Page 70



D66
Page 76

Hydra-Cell® Flow Capacities and Pressure Ratings

F/M/D/H Series Seal-less Pumps

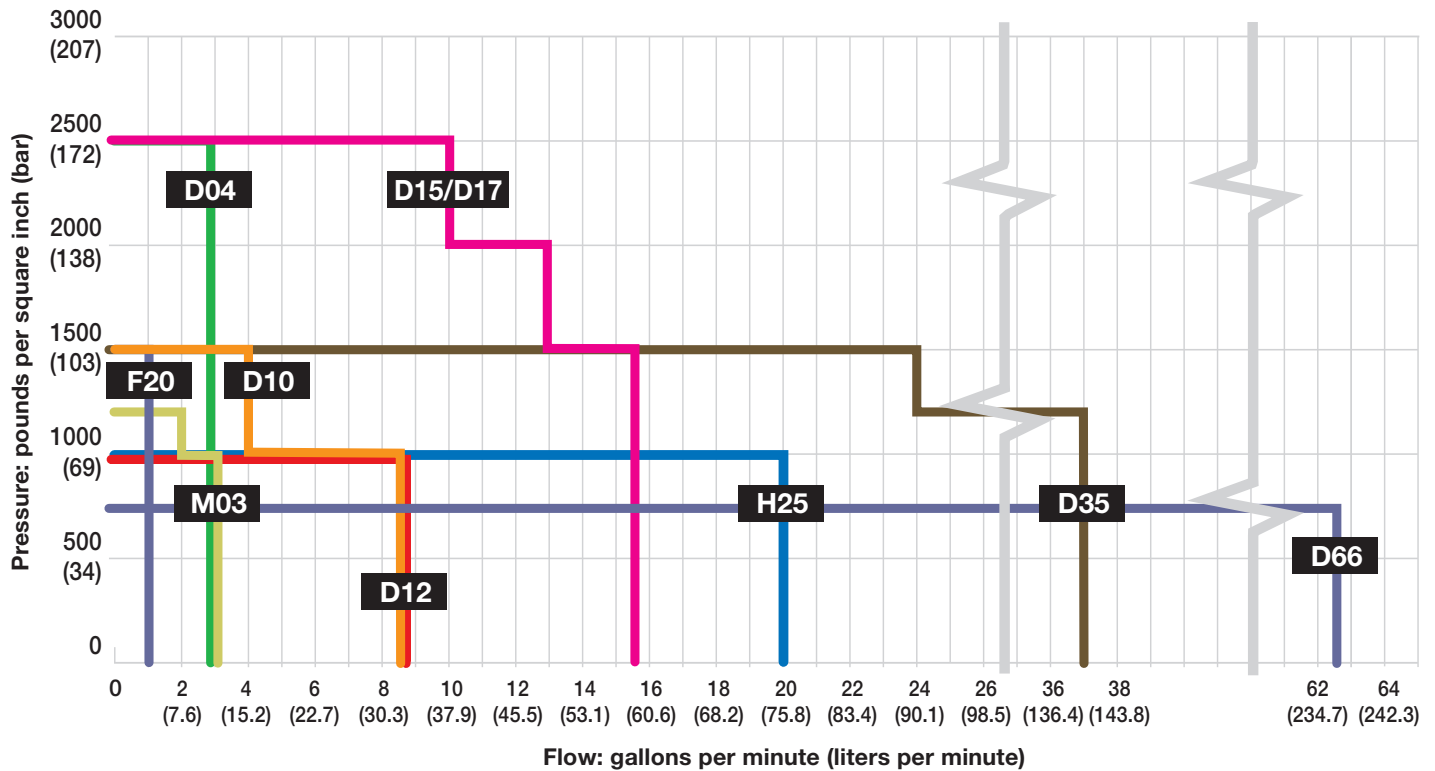

The graph above displays the maximum flow capacity at a given pressure for each model series. The table below lists the maximum flow capacity and maximum pressure capability of each model series.

Please Note: Some models do not achieve maximum flow at maximum pressure. Refer to the individual model specifications in this section for precise flow and pressure capabilities by specific pump configuration.

Model ¹	Maximum Capacity gpm (l/min)	Maximum Discharge Pressure psi (bar)		Maximum Operating Temperature F (C) ³		Maximum Inlet Pressure psi (bar)
		Non-metallic ²	Metallic	Non-metallic	Metallic	
F20	1.0 (3.8)	350 (24)	1500 (103)	140° (60°)	250° (121°)	250 (17)
M03	3.1 (11.7)	350 (24)	1200 (83)	140° (60°)	250° (121°)	250 (17)
D04	2.9 (11.2)	N/A	2500 (172)	N/A	250° (121°)	500 (34)
D10⁴	4.3 (15.1)	N/A	1500 (103)	N/A	250° (121°)	250 (17)
D10	8.8 (33.4)	350 (24)	1000 (69)	140° (60°)	250° (121°)	250 (17)
D12	8.8 (33.4)	N/A	1000 (69)	N/A	250° (121°)	250 (17)
D15 & D17	15.5 (58.7)	N/A	2500 (172)	N/A	250° (121°)	500 (34)
H25	20.0 (75.9)	350 (24)	1000 (69)	140° (60°)	250° (121°)	250 (17)
D35⁵	23.1 (87.5)	N/A	1500 (103)	N/A	250° (121°)	250 (17)
D35	36.5 (138)	N/A	1200 (83)	N/A	250° (121°)	500 (34)
D66	62.5 (236.6)	250 (17)	1000 (69)	120° (49°)	200° (93.3°)	250 (17) ⁶

¹ Ratings are for the cam design with the highest flow rate.

² 350 psi (24 bar) maximum with PVDF liquid end; 250 psi (17 bar) maximum with Polypropylene liquid end.

³ Consult factory for correct component selection for temperatures from 160°F (71°C) to 250°F (121°C).

⁴ D10 @790 rpm maximum.

⁵ D35 @700 rpm maximum; consult factory for pressures above 1200 psi (83 bar).

⁶ D66 maximum inlet pressure 50 psi (3.4 bar) for non-metallic models.

F20 Series

Maximum Flow Rate: 1.0 gpm (3.8 l/min)

Maximum Pressure: 1500 psi (103 bar) for Metallic Pump Heads
350 psi (24 bar) for Non-metallic Pump Heads



F20 close-coupled (hollow shaft) for 56C frame motors, shown with Brass pump head.



F21 external shaft-driven with Polypropylene pump head.



F22 flexible-coupled to 56C, 142TC, and 145TC frame motors, shown with 316L Stainless Steel pump head.

F20 Series Performance

Capacities

Flow

Model	Max. Input rpm	Max. Flow @ 1000 psi (69 bar)	
		gpm	l/min
F20-X	1750	1.01	3.82
F20-E	1750	0.71	2.69
F20-S	1750	0.56	2.12
F20-B	1750	0.31	1.17
F20-G	1750	0.20	0.76

Pressure

Maximum Inlet Pressure
250 psi (17 bar)

Maximum Discharge Pressure

Metallic Pump Heads:

F20 to 1000 psi (69 bar)

F21 to 1500 psi (103 bar)

F22 to 1500 psi (103 bar)

Non-metallic Pump Heads:

250 psi (17 bar) Polypropylene

350 psi (24 bar) PVDF

Performance and specification ratings apply to F20, F21 and F22 configurations unless specifically noted otherwise.

Maximum Flow at Designated Pressure

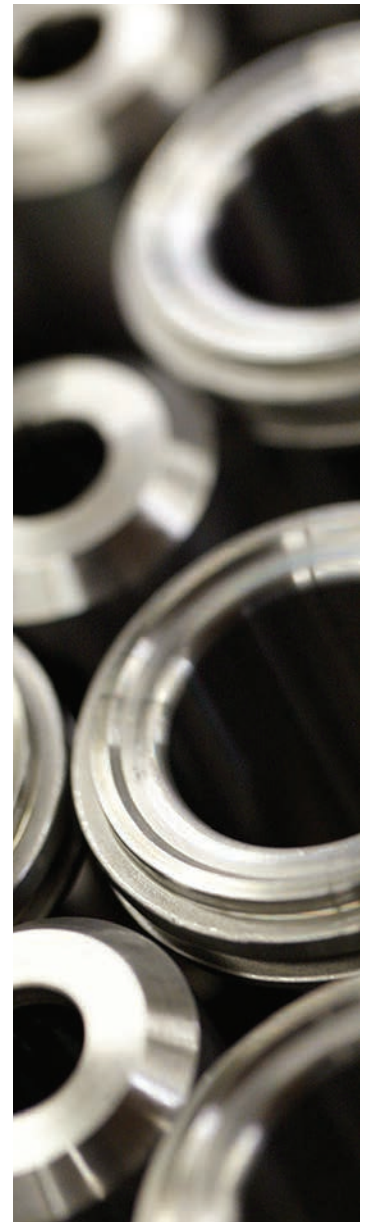
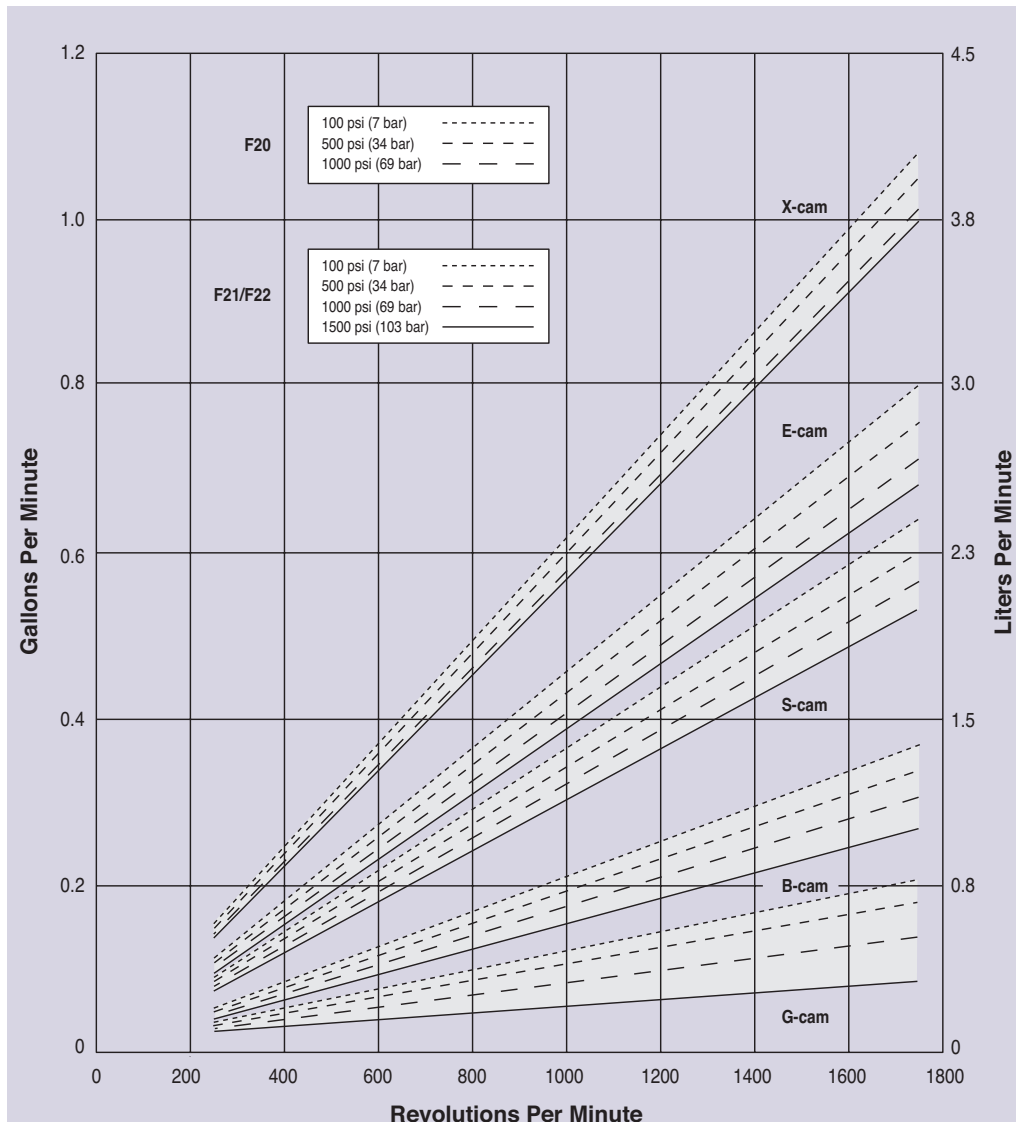

S, B & G cam options based on 10 psi (0.7 bar) inlet pressure.

F20 Series Specifications

Flow Capacities @1000 psi (69 bar)

Model	rpm	gpm	l/min
F20-X	1750	1.01	3.82
F20-E	1750	0.71	2.69
F20-S	1750	0.56	2.12
F20-B	1750	0.31	1.17
F20-G	1750	0.20	0.76

Delivery @1000 psi (69 bar)

Model	gal/rev	liters/rev
F20-X	0.0006	0.0022
F20-E	0.0004	0.0015
F20-S	0.0003	0.0012
F20-B	0.0002	0.0007
F20-G	0.0001	0.0004

Maximum Discharge Pressure

Metallic Heads:	F20 to 1000 psi (69 bar)
	F21 to 1500 psi (103 bar)
	F22 to 1500 psi (103 bar)
Non-metallic Heads:	250 psi (17 bar) Polypropylene
	350 psi (24 bar) PVDF

Maximum Inlet Pressure 250 psi (17 bar)

Maximum Operating Temperature

Metallic Heads:	250 °F (121 °C) - Consult factory for correct component selection for temperatures from 160 °F (71 °C) to 250 °F (121 °C).
Non-metallic Heads:	140 °F (60 °C)

Maximum Solids Size 200 microns

Inlet Port 1/2 inch NPT

Discharge Port 3/8 inch NPT

Shaft Diameter

F20: 5/8 inch hollow shaft
F21 & F22: 5/8 inch (15.9 mm) external shaft

Shaft Rotation Reverse (bi-directional)

Bearings Precision ball bearings

Oil Capacity 0.125 US quart (0.12 liters) - See pages 100 and 101 for oil selection and specification.

Weight

Metallic Heads:	12 lbs. (5.5 kg)
Non-metallic Heads:	9 lbs. (4.1 kg)

Calculating Required Power

$$\frac{\text{rpm} + 1000}{7000} + \frac{\text{gpm} \times \text{psi}}{1,460} = \text{electric motor hp}$$

$$\frac{\text{rpm} + 1000}{9383} + \frac{\text{l/min} \times \text{bar}}{511} = \text{electric motor kW}$$

When using a variable frequency drive (VFD) controller calculate the hp or kW at minimum and maximum pump speed to ensure the correct hp or kW motor is selected. Note that motor manufacturers typically de-rate the service factor to 1.0 when operating with a VFD.

See page 190 for calculating pulley size.

Net Positive Suction Head (NPSHr)

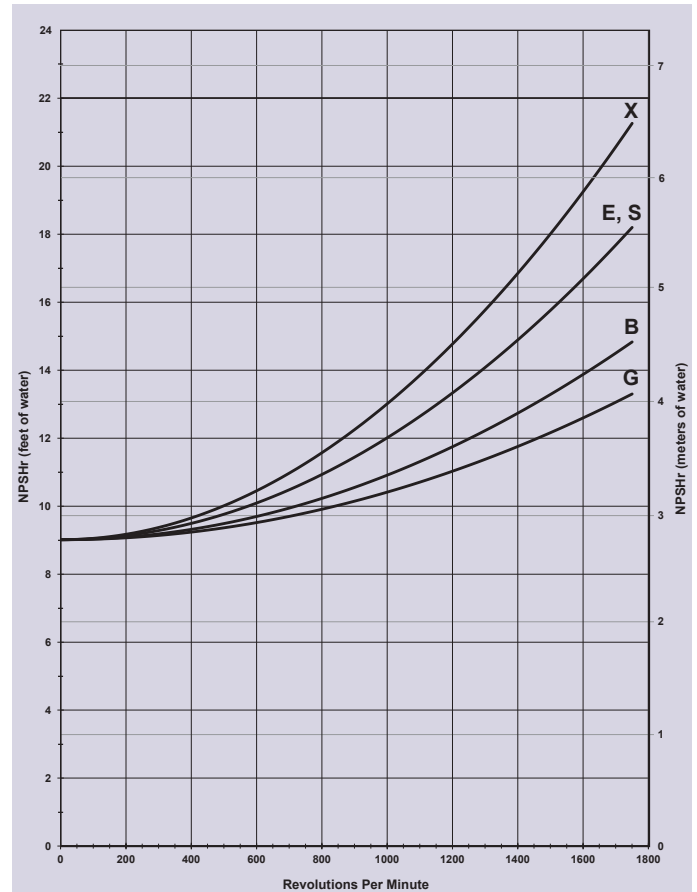

Positive inlet pressure required for:

- A) All pumps with PTFE diaphragms
- B) Pumps with B-cam or G-cam (consult factory)

Suction Lift:

Each Hydra-Cell pump has different lift capability depending on model size, cam angle, speed, and fluid characteristics. To ensure that your specific lift characteristics are met, refer to the inlet calculations regarding friction, and acceleration head losses in your Hydra-Cell Installation & Service Manual. Compare those calculations to the NPSHr curves above.

For technical assistance in pump selection, see Frequently Asked Questions on page 188, Design Considerations on page 189, and Installation Guidelines on pages 190-191.

F20 Series Representative Drawings

F20 Models with Metallic Pump Head Inches (mm)

* Add 0.25" (6.35mm) where shown for manifold cover plate on non-metallic models.

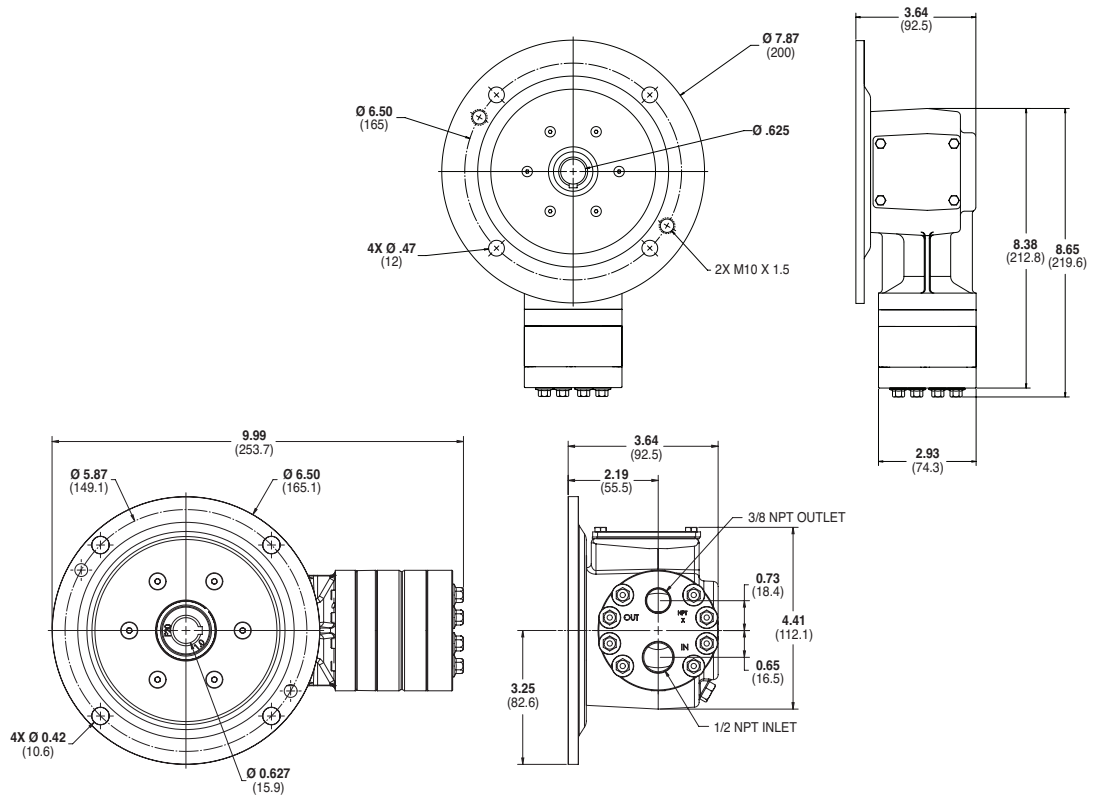

F21 Models with Metallic Pump Head Inches (mm)

* Add 0.25" (6.35mm) where shown for manifold cover plate on non-metallic models.

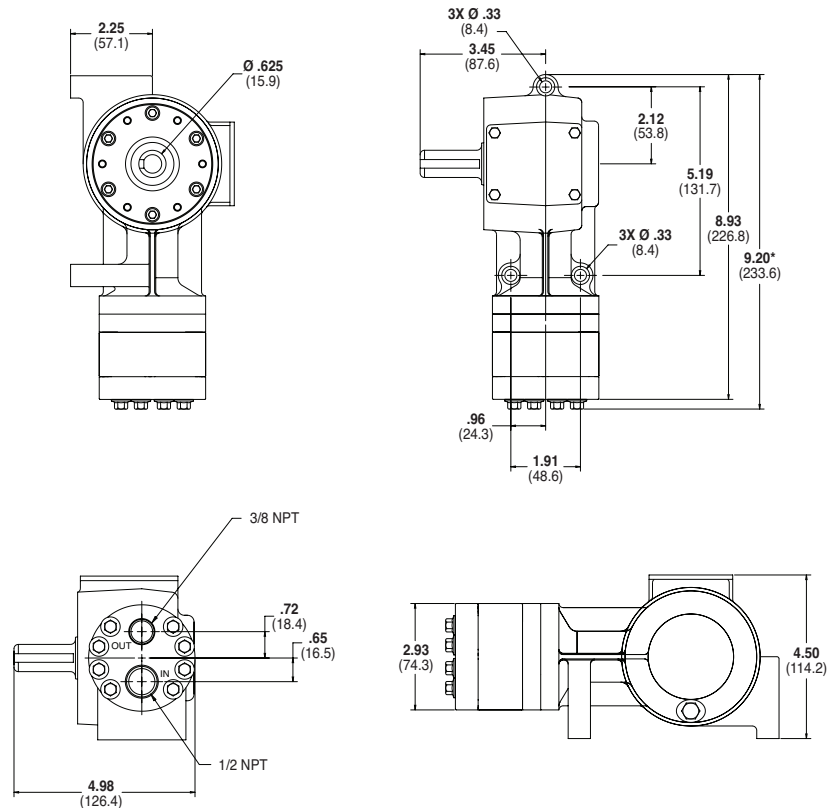

Note: Dimensions are for reference only. Contact factory for certified drawings.

F20 Series Drawings/Adapters/Valves

F22 Models with Metallic Pump Head Inches (mm)

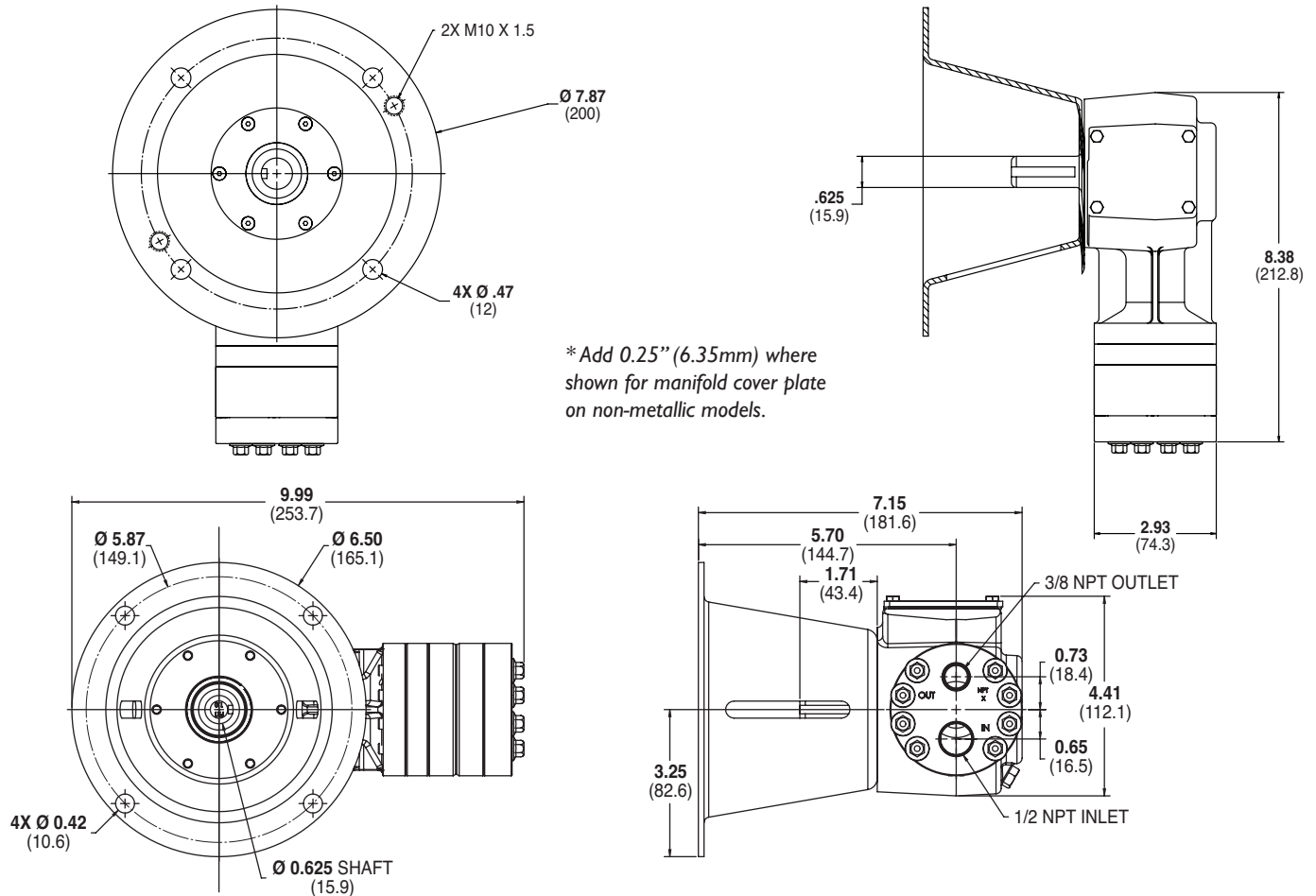

Note: Dimensions are for reference only. Contact factory for certified drawings.

Pump/Motor Adapter Inches (mm)

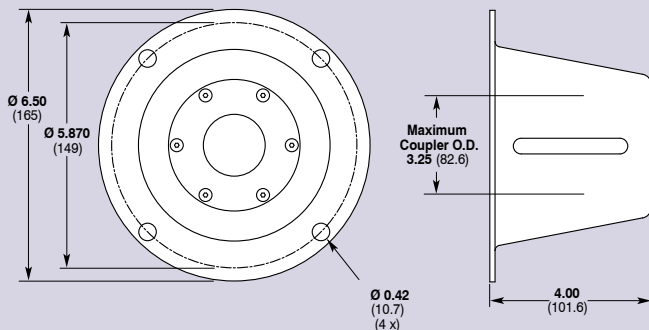

Part Number: A04-005-1200

Must be ordered separately for F22 models (optional for F21 models) with 56C, I43TC and I45TC frame motors.

Metric adapter available - consult factory.

Valve Selection

A Hydra-Cell F20, F21 or F22 pumping system uses a C46 Pressure Regulating Valve.

See page 86 for more information.



F20 Series How to Order

Ordering Information



A complete F20 Series Model Number contains 12 digits including 9 customer-specified design and materials options, for example: F20GAPGHFECC.

Digit	Order Code	Description
1-3		Pump Configuration
	F20	Close-coupled to NEMA 56C footed motor (NPT Ports)
	F21	Shaft-driven (NPT Ports)*
	F22	For use with pump/motor adapter (NPT Ports)* *Pump/motor adapters ordered separately. See previous page.
4		Hydraulic End Cam
	X	Max 1.01 gpm (3.8 l/min) @ 1750 rpm
	E	Max 0.71 gpm (2.7 l/min) @ 1750 rpm
	S	Max 0.56 gpm (2.1 l/min) @ 1750 rpm
	B	Max 0.31 gpm (1.2 l/min) @ 1750 rpm**
	G	Max 0.20 gpm (0.8 l/min) @ 1750 rpm**
5		Pump Head Version
	A	NPT Ports (for all F20, F21 & F22 pumps)
6		Pump Head Material
	B	Brass
	M	PVDF
	P	Polypropylene
	S	316L Stainless Steel
	T	Hastelloy C
7		Diaphragm & O-ring Material
	A	Aflas diaphragm/PTFE o-ring
	E	EPDM (requires EPDM-compatible oil - Digit 12 oil code J)
	G	FKM
	J	PTFE (available with X and E cams only)**
	P	Neoprene
	T	Buna-N
8		Valve Seat Material
	C	Ceramic
	D	Tungsten Carbide
	H	17-4 Stainless Steel
	S	316L Stainless Steel
	T	Hastelloy C

Digit	Order Code	Description
9		Valve Material
	C	Ceramic
	D	Tungsten Carbide
	F	17-4 Stainless Steel
	N	Nitronic 50
	T	Hastelloy C
10		Valve Springs
	E	Elgiloy
	T	Hastelloy C
11		Valve Spring Retainers
	C	Celcon
	H	17-7 Stainless Steel (used with metallic heads only)
	M	PVDF
	P	Polypropylene
	T	Hastelloy C (used with metallic heads only)
	Y	Nylon
12		Hydra-Oil
	G	5W30 cold-temp severe-duty synthetic oil
	J	EPDM-compatible oil
	K	Food-contact oil

Note: For motors, bases, couplings and other pump accessories, refer to the Accessories section beginning on page 92.

**Positive inlet pressure required for B and G cams and for PTFE diaphragms.

M03 Series

Maximum Flow Rate: 3.1 gpm (11.7 l/min)

Maximum Pressure: 1200 psi (83 bar) for Metallic Pump Heads
350 psi (24 bar) for Non-metallic Pump Heads



*M03 close-coupled (hollow shaft)
with Brass pump head.*



M03 close-coupled (hollow shaft) with Polypropylene pump head.



D03 external shaft-driven with 316L Stainless Steel pump head.

M03 Series Performance

Capacities

Flow

Model	Max. Input rpm	Max. Flow @ 1000 psi (69 bar)	
		gpm	l/min
M03-X	1750	3.1	11.7
M03-E	1750	2.2	8.3
M03-S	1750	1.7	6.4
M03-B	1750	1.0	3.6
M03-G	1750	0.6	2.3
@ 1200 psi (83 bar)			
M03-E	1750	2.1	8.1
M03-S	1750	1.6	6.3
M03-B	1750	0.9	3.5
M03-G	1750	0.6	2.2

Pressure

Maximum Inlet Pressure

250 psi (17 bar)

Maximum Discharge Pressure

Metallic Pump Heads:

M03-X to 1000 psi (69 bar)

M03-S, E, B, G to 1200 psi (83 bar)

Non-metallic Pump Heads:

250 psi (17 bar) Polypropylene

350 psi (24 bar) PVDF

Performance and specification ratings apply to M03 Kel-Cell and D03 external shaft-driven configurations unless specifically noted otherwise.

Maximum Flow at Designated Pressure

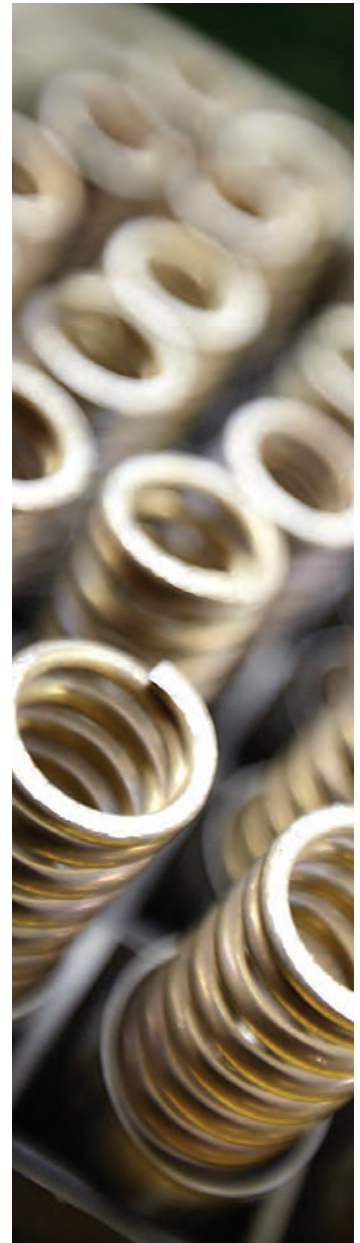
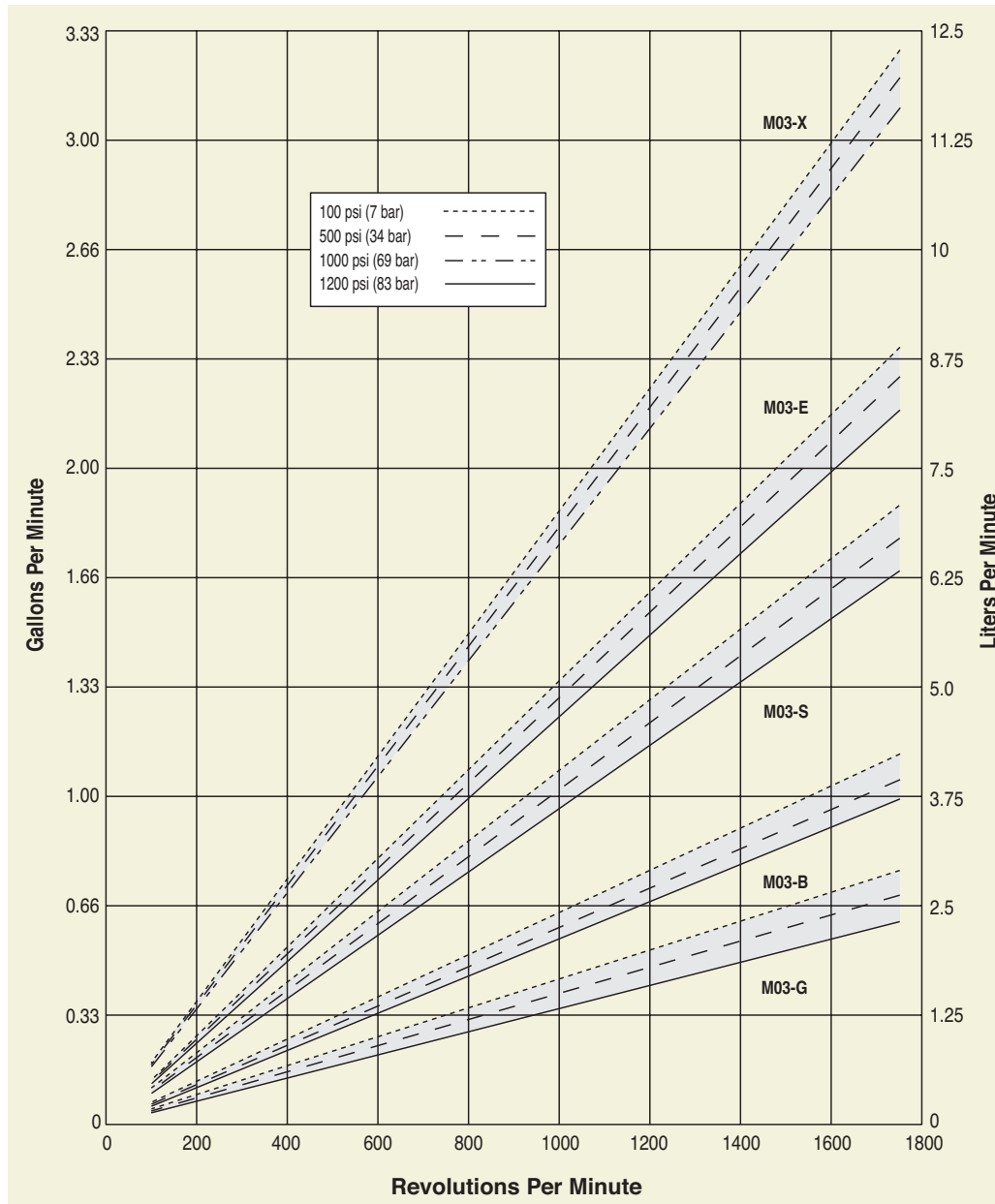

M03 Series Specifications

Flow Capacities @1000 psi (69 bar)

Model	rpm	gpm	l/min
M03-X	1750	3.10	11.73
M03-E	1750	2.18	8.25
M03-S	1750	1.69	6.40
M03-B	1750	0.96	3.63
M03-G	1750	0.62	2.35

Delivery @1200 psi (83 bar)

Model	gal/rev	liters/rev
M03-E	0.0012	0.0046
M03-S	0.0009	0.0036
M03-B	0.0005	0.0020
M03-G	0.0003	0.0013

Delivery @1000 psi (69 bar)

Model	gal/rev	liters/rev
M03-X	0.0018	0.0067
M03-E	0.0013	0.0047
M03-S	0.0010	0.0037
M03-B	0.0005	0.0021
M03-G	0.0004	0.0013

Maximum Discharge Pressure

Metallic Heads:	M03-X to 1000 psi (69 bar)
	M03-S, E, B to 1200 psi (83 bar)
Non-metallic Heads:	250 psi (17 bar) Polypropylene
	350 psi (24 bar) PVDF

Maximum Inlet Pressure 250 psi (17 bar)

Maximum Operating Temperature

Metallic Heads:	250 °F (121 °C) - Consult factory for correct component selection for temperatures from 160 °F (71 °C) to 250 °F (121 °C).
Non-metallic Heads:	140 °F (60 °C)

Maximum Solids Size 200 microns

Inlet Port

Primary:	1/2 inch NPT
Secondary:	3/8 inch NPT (plugged from factory)

Discharge Port 3/8 inch NPT

Shaft Diameter

M03: 5/8 inch hollow shaft
D03: 7/8 inch (22.2 mm) external shaft

Shaft Rotation Reverse (bi-directional)

Bearings Precision ball bearings

Oil Capacity 1.0 US quart (0.95 liters) - See pages 100 and 101 for oil selection and specification.

Weight

Metallic Heads:	28 lbs. (12.7 kg)
Non-metallic Heads:	19 lbs. (8.6 kg)

Net Positive Suction Head (NPSHr)

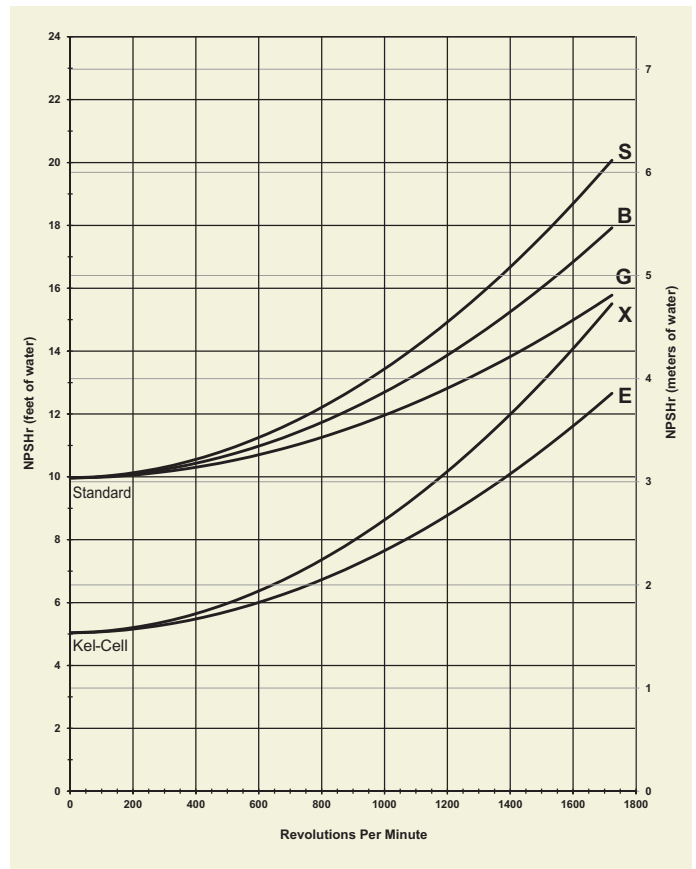

Suction Lift:

Each Hydra-Cell pump has different lift capability depending on model size, cam angle, speed, and fluid characteristics. To ensure that your specific lift characteristics are met, refer to the inlet calculations regarding friction, and acceleration head losses in your Hydra-Cell Installation & Service Manual. Compare those calculations to the NPSHr curves above.

Calculating Required Power

$$\frac{6 \times \text{rpm}}{63,000} + \frac{\text{gpm} \times \text{psi}}{1,460} = \text{electric motor hp}$$

$$\frac{6 \times \text{rpm}}{84,428} + \frac{\text{l/min} \times \text{bar}}{511} = \text{electric motor kW}$$

When using a variable frequency drive (VFD) controller calculate the hp or kW at minimum and maximum pump speed to ensure the correct hp or kW motor is selected. Note that motor manufacturers typically de-rate the service factor to 1.0 when operating with a VFD.

See page 190 for calculating pulley size.

For technical assistance in pump selection, see Frequently Asked Questions on page 188, Design Considerations on page 189, and Installation Guidelines on pages 190-191.

M03 Series Representative Drawings

M03 Models with Metallic Pump Head Inches (mm)

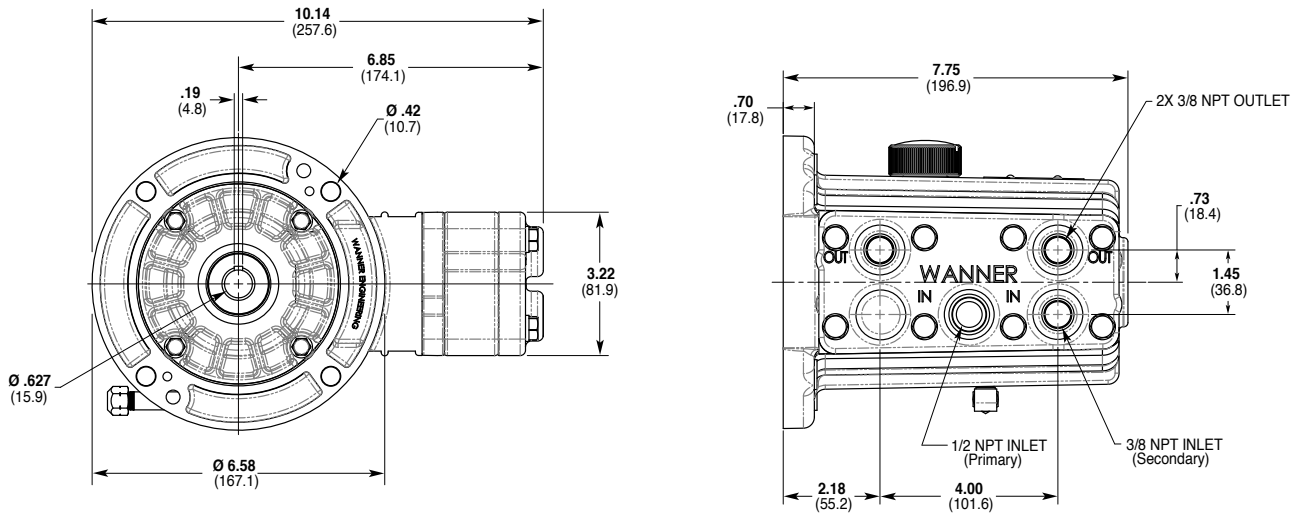

* Add 0.38" (9.65 mm) overall length where shown for manifold cover plate on non-metallic models and 0.20" (5.08 mm) for bolt heads attaching the plate.

D03 Models with Metallic Pump Head Inches (mm)

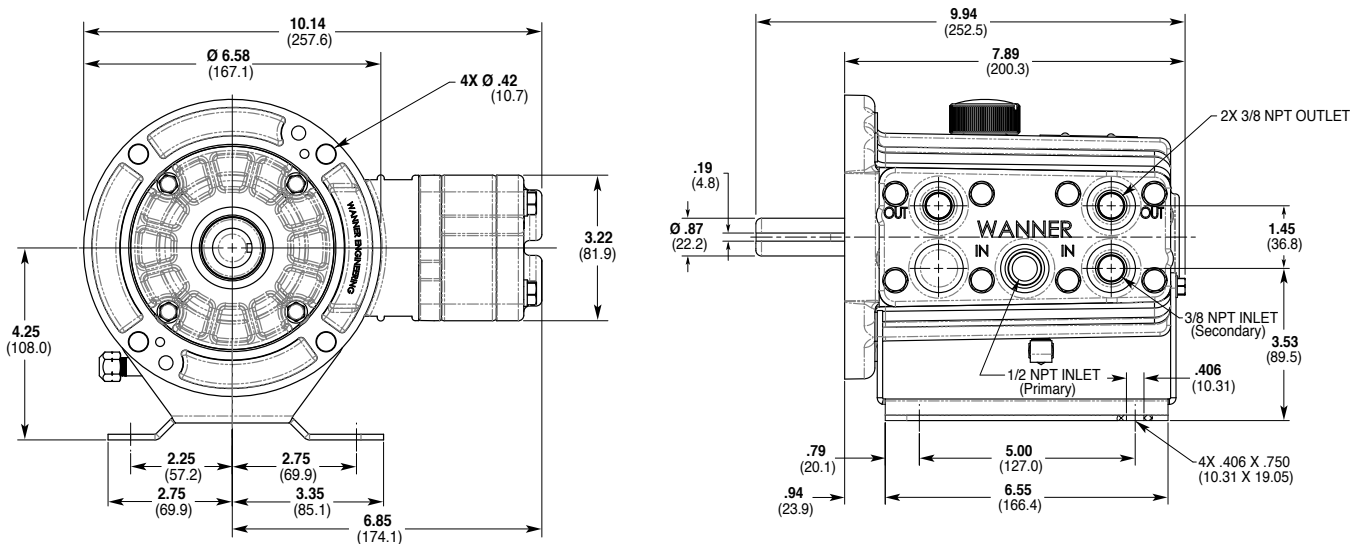

* Add 0.38" (9.65 mm) overall length where shown for manifold cover plate on non-metallic models and 0.20" (5.08 mm) for bolt heads attaching the plate.

Note: Dimensions are for reference only. Contact factory for certified drawings.

M03 Series **Adapters/Valves**

Pump/Motor Adapter Inches (mm)

Part Number: A04-001-I202

Must be ordered separately for D03 models for use with 56C, I43TC and I45TC frame motors.

Metric adapter available - consult factory.

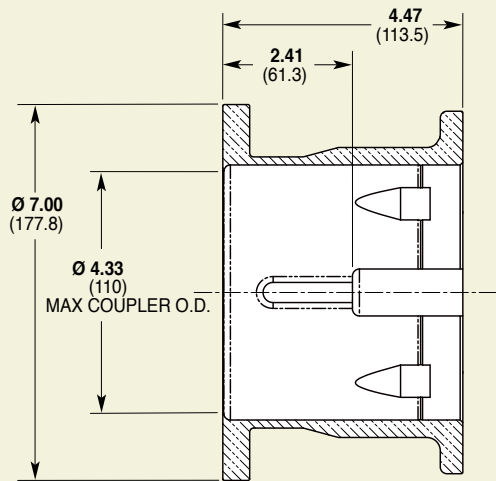

Part Number: A04-002-I202

Must be ordered separately for D03 models for use with I82TC, I84TC, 2I3TC and 2I5TC frame motors.

Metric adapter available - consult factory.

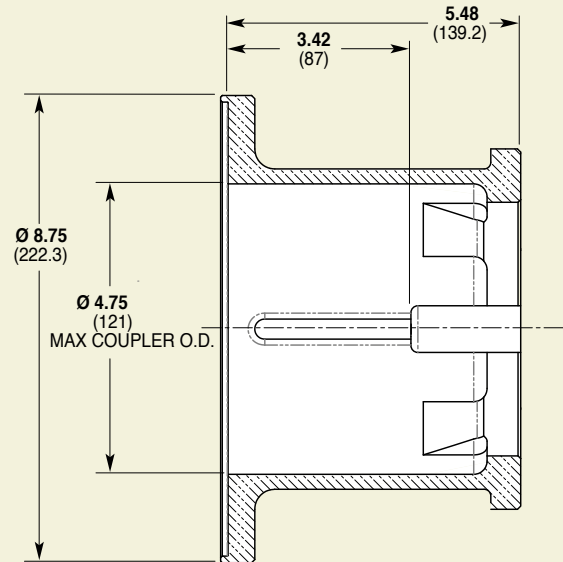

Valve Selection

A Hydra-Cell M03/D03 pumping system uses a C46 Pressure Regulating Valve.

See page 86 for more information.



M03 Series **How to Order**

Ordering Information

1	2	3	4	5	6	7	8	9	10	11	12
	0	3									

A complete M03 Series Model Number contains 12 digits including 10 customer-specified design and materials options, for example: M03XKSTHFECA.

Digit	Order Code	Description
1-3		Pump Configuration
	D03	Shaft-driven (NPT Ports)*
	M03	Close-coupled to NEMA 56C footed motor (NPT Ports) *Pump/motor adapters ordered separately. See previous page.
4		Hydraulic End Cam
	X	Max 3.1 gpm (11.7 l/min) @ 1750 rpm
	E	Max 2.2 gpm (8.3 l/min) @ 1750 rpm
	S	Max 1.7 gpm (6.4 l/min) @ 1750 rpm
	B	Max 1.0 gpm (3.6 l/min) @ 1750 rpm
5		Pump Head Version
	A	Standard NPT Ports (S, B & G cams)
	K	Kel-Cell NPT Ports (X & E cams)
6		Pump Head Material
	B	Brass
	M	PVDF
	P	Polypropylene
	S	316L Stainless Steel
7		Diaphragm & O-ring Material
	A	Aflas diaphragm/PTFE o-ring
	E	EPDM (requires EPDM-compatible oil - Digit 12 oil code J)
	G	FKM
	J	PTFE
	P	Neoprene
8		Valve Seat Material
	C	Ceramic
	D	Tungsten Carbide
	H	17-4 Stainless Steel
	S	316L Stainless Steel
T	Hastelloy C	

Digit	Order Code	Description
9		Valve Material
	C	Ceramic
	D	Tungsten Carbide
	F	17-4 Stainless Steel
	N	Nitronic 50
10		Valve Springs
	E	Elgiloy
	S	316L Stainless Steel
11		Valve Spring Retainers
	C	Celcon
	H	17-7 Stainless Steel (used with metallic heads only)
	M	PVDF
	P	Polypropylene
	T	Hastelloy C (used with metallic heads only)
12		Hydra-Oil
	A	10W30 standard-duty oil
	G	5W30 cold-temp severe-duty synthetic oil
	J	EPDM-compatible oil
	K	Food-contact oil

Note: For motors, bases, couplings and other pump accessories, refer to the Accessories section beginning on page 92.

M03 Mono-Block Series

Maximum Flow Rate: 3.1 gpm (11.7 l/min)

Maximum Pressure: 1000 psi (69 bar) for Metallic Pump Heads



M03 Mono-Block, close-coupled (hollow shaft) with 316L Stainless Steel pump head.



D03 Mono-Block, external shaft-driven with Brass pump head.

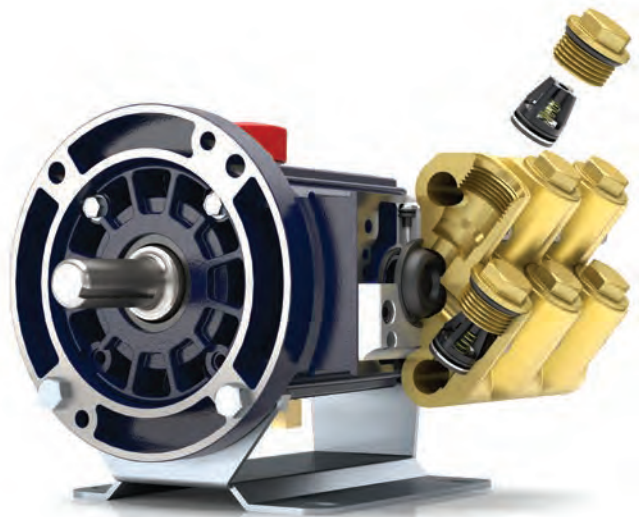

The Mono-Block pump head combines the valve plate and manifold into one component for servicing without disassembly or removal of plumbing.

M03 Mono-Block Series Performance

Capacities

Flow

Model	Max. Input rpm	Max. Flow @ 1000 psi (69 bar)	
		gpm	l/min
M03-X	1750	3.1	11.7
M03-E	1750	2.2	8.3

Pressure

Maximum Inlet Pressure
250 psi (17 bar)

Maximum Discharge Pressure
1000 psi (69 bar)

Performance and specification ratings apply to M03 and D03 Mono-Block configurations unless specifically noted otherwise.

Maximum Flow at Designated Pressure

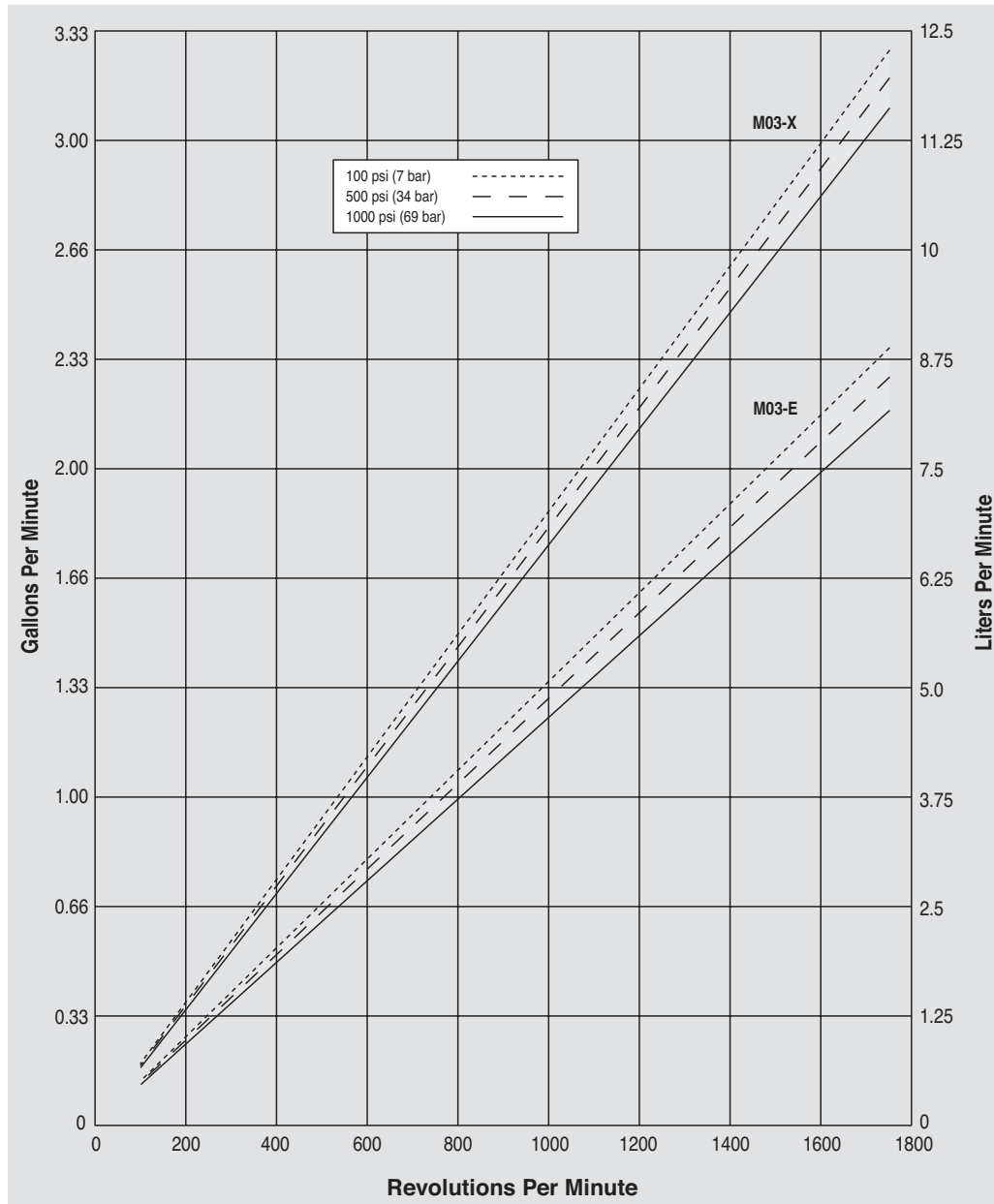

M03 Mono-Block Series Specifications

Flow Capacities @1000 psi (69 bar)

Model	rpm	gpm	l/min
M03-X	1750	3.10	11.73
M03-E	1750	2.18	8.25

Delivery @1000 psi (69 bar)

Model	gal/rev	liters/rev
M03-X	0.0018	0.0067
M03-E	0.0013	0.0047

Maximum Discharge Pressure

Metallic Heads: M/D03-X, E to 1000 psi (69 bar)

Maximum Inlet Pressure 250 psi (17 bar)

Maximum Operating Temperature

Metallic Heads: 250° F (121° C) - Consult factory for correct component selection for temperatures from 160° F (71° C) to 250° F (121° C).

Maximum Solids Size 200 microns

Inlet Port 1/2 inch NPT

Discharge Port 1/2 inch NPT

Shaft Diameter

M03: 5/8 inch hollow shaft
D03: 7/8 inch (22.2 mm) external shaft

Shaft Rotation Reverse (bi-directional)

Bearings Precision ball bearings

Oil Capacity 1.0 US quart (0.95 liters) - See pages 100 and 101 for oil selection and specification.

Weight

Metallic Heads: 28 lbs. (12.7 kg)

Net Positive Suction Head (NPSHr)

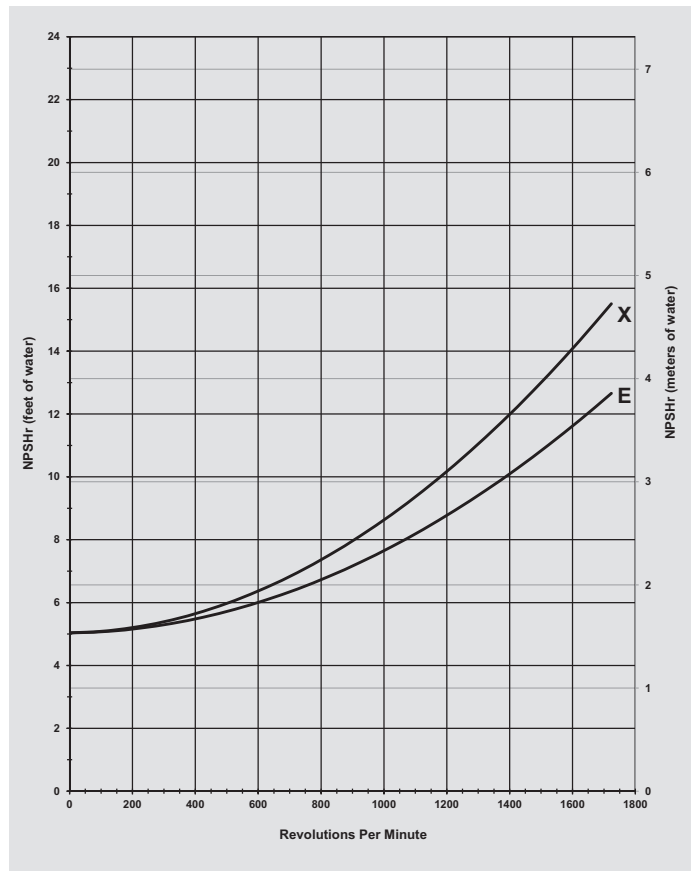

Suction Lift:

Each Hydra-Cell pump has different lift capability depending on model size, cam angle, speed, and fluid characteristics. To ensure that your specific lift characteristics are met, refer to the inlet calculations regarding friction, and acceleration head losses in your Hydra-Cell Installation & Service Manual. Compare those calculations to the NPSHr curves above.

Calculating Required Power

$$\frac{6 \times \text{rpm}}{63,000} + \frac{\text{gpm} \times \text{psi}}{1,460} = \text{electric motor hp}$$

$$\frac{6 \times \text{rpm}}{84,428} + \frac{\text{l/min} \times \text{bar}}{511} = \text{electric motor kW}$$

When using a variable frequency drive (VFD) controller calculate the hp or kW at minimum and maximum pump speed to ensure the correct hp or kW motor is selected. Note that motor manufacturers typically de-rate the service factor to 1.0 when operating with a VFD.

See page 190 for calculating pulley size.

For technical assistance in pump selection, see *Frequently Asked Questions* on page 188, *Design Considerations* on page 189, and *Installation Guidelines* on pages 190-191.

M03 Mono-Block Series Representative Drawings

M03 Models with Metallic Pump Head Inches (mm)

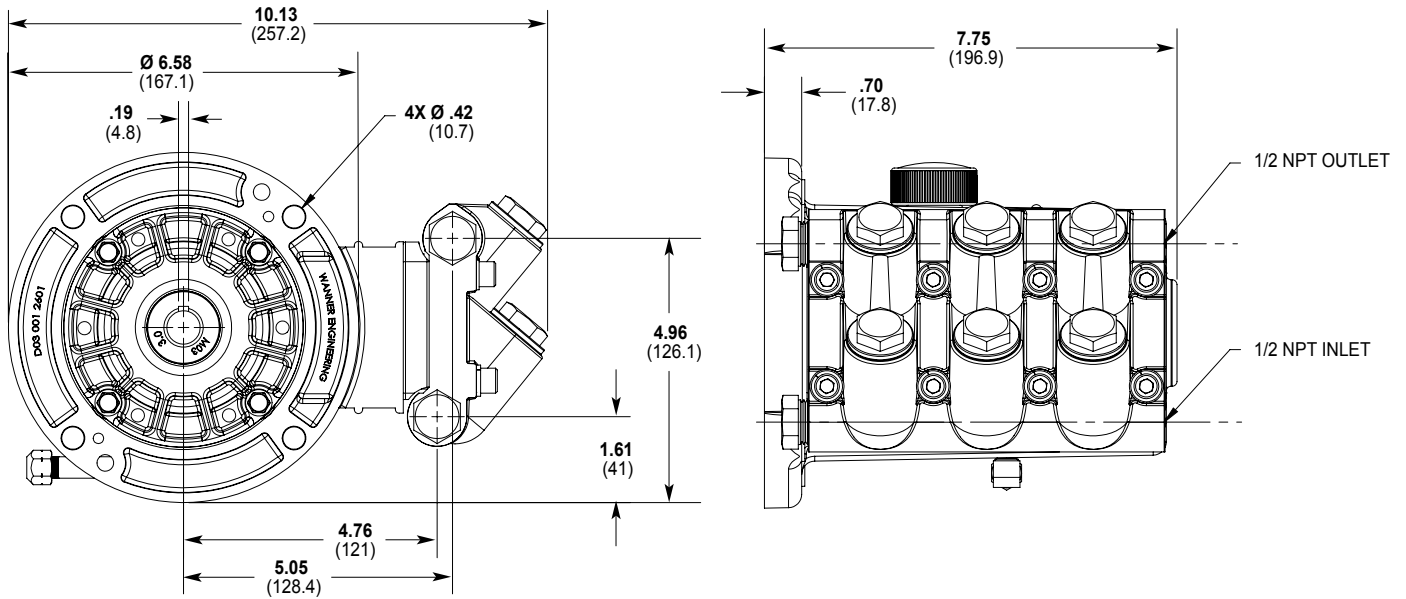

D03 Models with Metallic Pump Head Inches (mm)

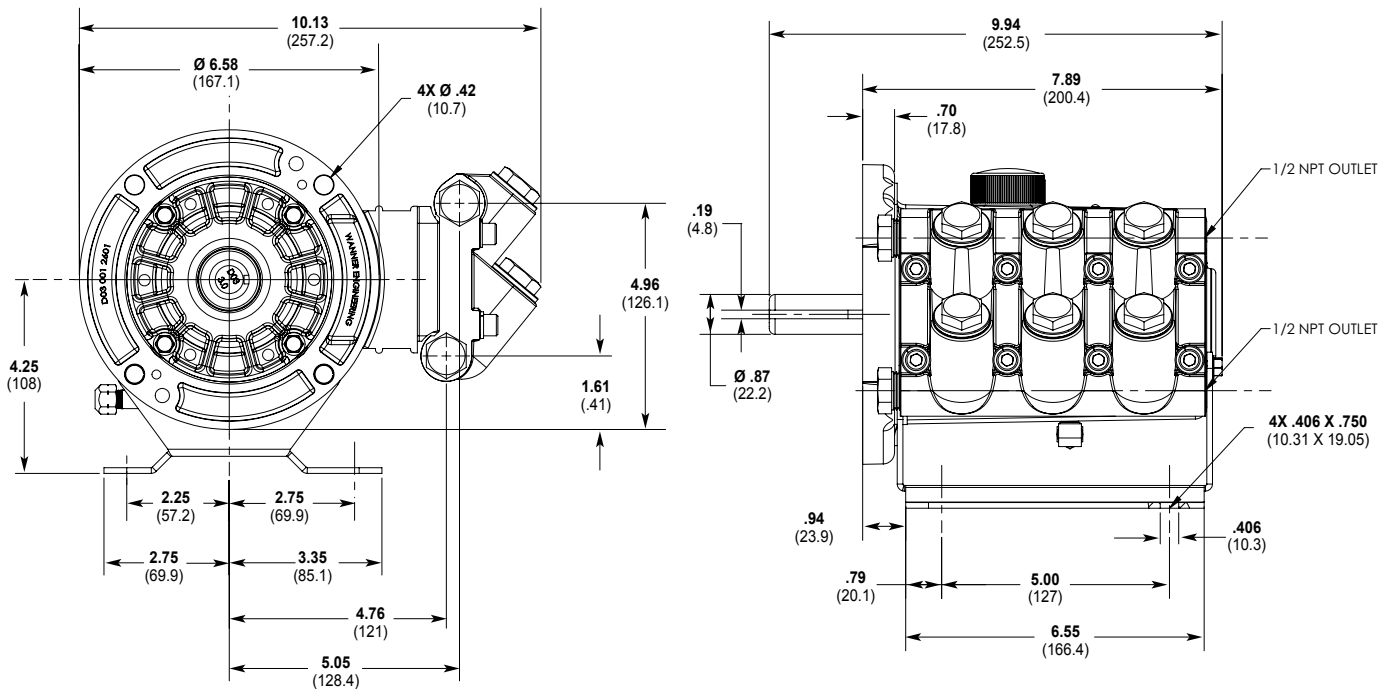

Note: Dimensions are for reference only. Contact factory for certified drawings.

M03 Mono-Block Series Adapters/Valves

Pump/Motor Adapter Inches (mm)

Part Number: A04-001-I202

Must be ordered separately for M03 Mono-Block models for use with 56C, 143TC and 145TC frame motors.

Metric adapter available - consult factory.

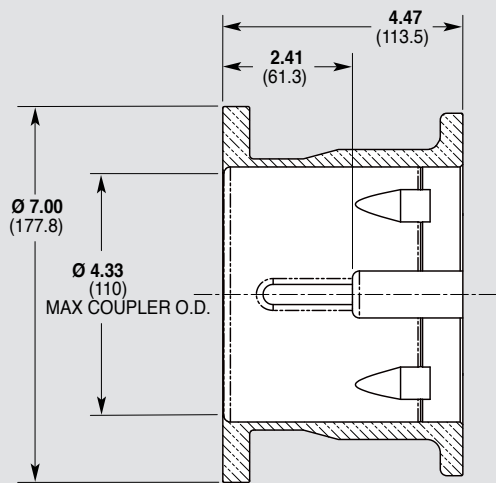

Part Number: A04-002-I202

Must be ordered separately for M03 Mono-Block models for use with 182TC, 184TC, 213TC and 215TC frame motors.

Metric adapter available - consult factory.

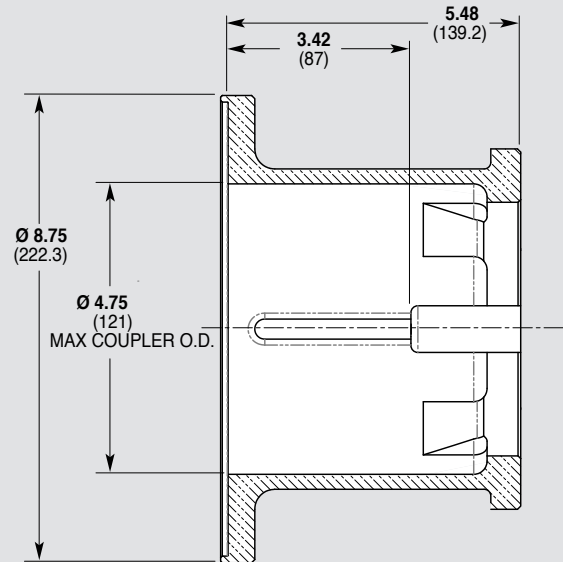

Valve Selection

A Hydra-Cell M03 Mono-Block Series pumping system uses a C46 Pressure Regulating Valve.

See page 86 for more information.



M03 Mono-Block Series How to Order

Ordering Information



A complete M03 Mono-Block Series Model Number contains 12 digits including 9 customer-specified design and materials options, for example: M03EMBPSFEPG.

Digit	Order Code	Description
1-3		Pump Configuration
	D03	Shaft-driven (NPT Ports)*
	M03	Close-coupled to NEMA 56C footed motor (NPT Ports) *Pump/motor adapters ordered separately. See previous page.
4		Hydraulic End Cam
	X	Max 3.1 gpm (11.7 l/min) @ 1750 rpm
	E	Max 2.2 gpm (8.3 l/min) @ 1750 rpm
5		Pump Head Version
	M	Mono-Block, Kel-Cell NPT Ports
6		Pump Head Material
	B	Brass
	S	316L Stainless Steel
7		Diaphragm & O-ring Material
	E	EPDM (requires EPDM-compatible oil - Digit 12 oil code J)
	G	FKM
	P	Neoprene
	T	Buna-N
8		Valve Seat Material
	H	17-4 Stainless Steel
	S	316L Stainless Steel
9		Valve Material
	F	17-4 Stainless Steel
	N	Nitronic 50
10		Valve Springs
	E	Elgiloy
	S	316L Stainless Steel
11		Valve Spring Retainers
	M	PVDF
	P	Polypropylene

Digit	Order Code	Description
12		Hydra-Oil
	A	10W30 standard-duty oil
	G	5W30 cold-temp severe-duty synthetic oil
	J	EPDM-compatible oil
	K	Food-contact oil

Note: For motors, bases, couplings and other pump accessories, refer to the Accessories section beginning on page 92.

D04 Series

Maximum Flow Rate: 2.9 gpm (11.2 l/min)

Maximum Pressure: 2500 psi (172 bar) for Metallic Pump Heads



D04 shaft-driven with 316L Stainless Steel pump head.



D04 shaft-driven with Brass pump head.

D04 Series Performance

Capacities

Flow

Model	Max. Input rpm	Max. Flow @ 2500 psi (172 bar)	
		gpm	l/min
D04-X	1750	2.9	11.2
D04-E	1750	2.0	7.7
D04-S	1750	1.6	6.2

Pressure

Maximum Inlet Pressure
500 psi (34 bar)

Maximum Discharge Pressure
2500 psi (172 bar)

Performance and specification ratings apply to D04 configurations unless specifically noted otherwise.

Maximum Flow at Designated Pressure

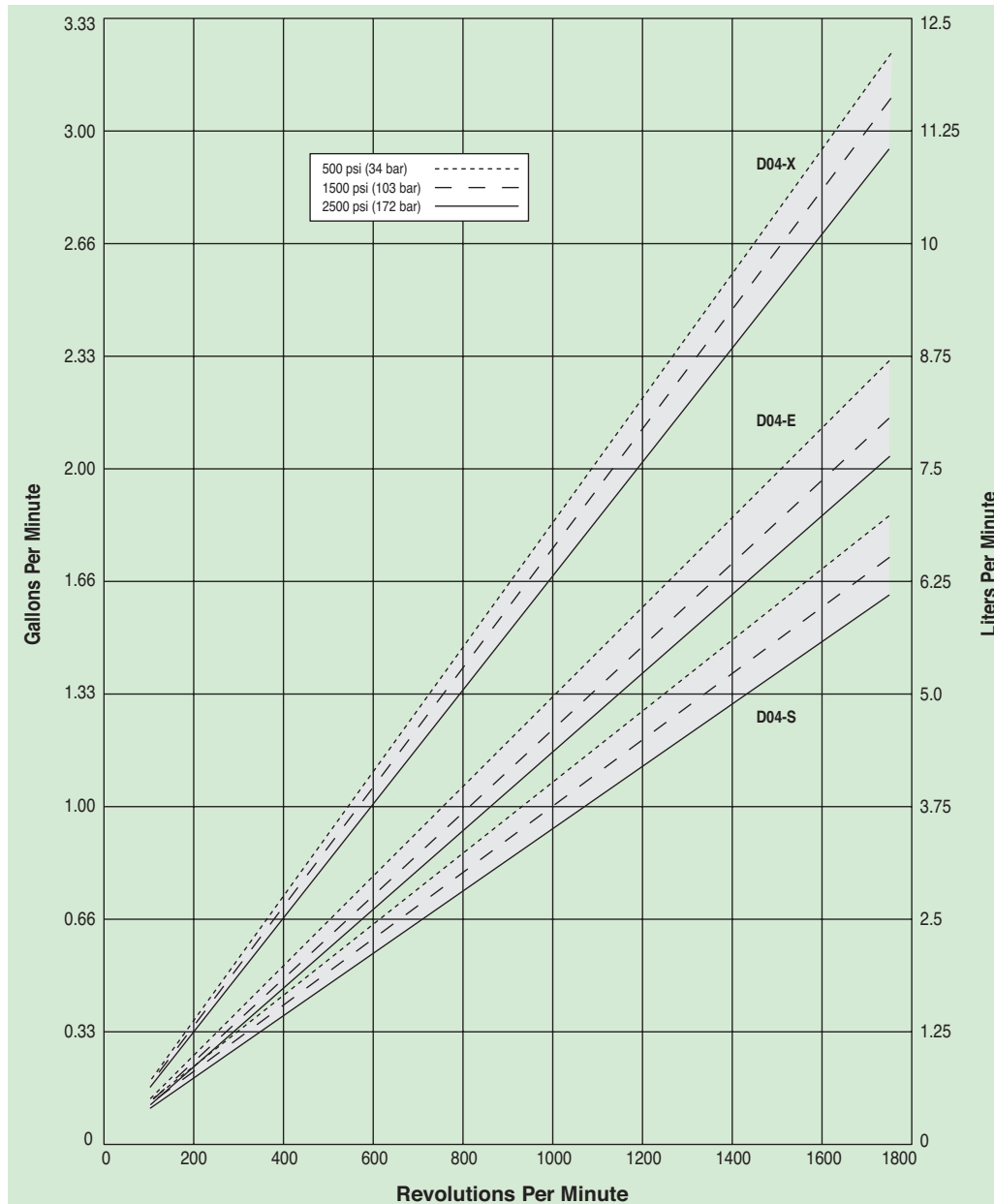

D04 Series Specifications

Flow Capacities @2500 psi (172 bar)

Model	rpm	gpm	l/min
D04-X	1750	2.95	11.16
D04-E	1750	2.04	7.71
D04-S	1750	1.63	6.19

Delivery

Model	gal/rev		
	@500 psi (34 bar)	@1500 psi (103 bar)	@2500 psi (172 bar)
D04-X	0.0019	0.0018	0.0017
D04-E	0.0013	0.0012	0.0012
D04-S	0.0011	0.0010	0.0009

Model	liters/rev		
	@500 psi (34 bar)	@1500 psi (103 bar)	@2500 psi (172 bar)
D04-X	0.0070	0.0067	0.0064
D04-E	0.0050	0.0047	0.0044
D04-S	0.0041	0.0039	0.0035

Maximum Discharge Pressure

Metallic Heads: 2500 psi (172 bar)

Maximum Inlet Pressure 500 psi (34 bar)

Maximum Operating Temperature

Metallic Heads: 250 °F (121 °C) - Consult factory for correct component selection for temperatures from 160 °F (71 °C) to 250 °F (121 °C).

Maximum Solids Size 200 microns

Inlet Port 1/2 inch NPT
600lb ANSI RF flange

Discharge Port 1/2 inch NPT
2500lb ANSI RF flange

Shaft Diameter 7/8 inch (22.2 mm)

Shaft Rotation Reverse (bi-directional)

Bearings Precision ball bearings

Oil Capacity 1.1 US quarts (1.05 liters)

Weight 37 lbs. (16.8 kg)

Net Positive Suction Head (NPSHr)

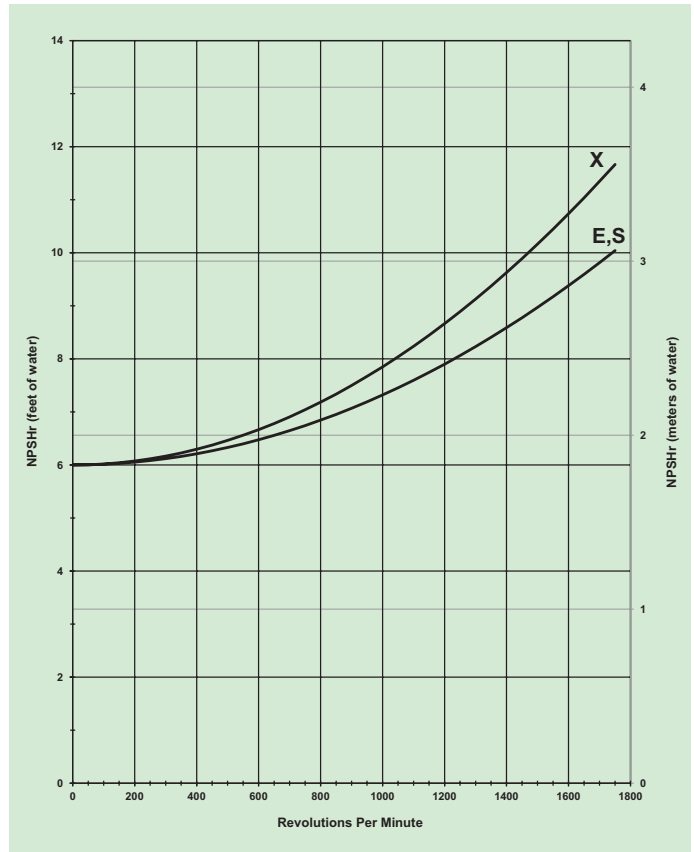

Suction Lift:

Each Hydra-Cell pump has different lift capability depending on model size, cam angle, speed, and fluid characteristics. To ensure that your specific lift characteristics are met, refer to the inlet calculations regarding friction, and acceleration head losses in your Hydra-Cell Installation & Service Manual. Compare those calculations to the NPSHr curves above.

Calculating Required Power

$$\frac{6 \times \text{rpm}}{63,000} + \frac{\text{gpm} \times \text{psi}}{1,460} = \text{electric motor hp}$$

$$\frac{6 \times \text{rpm}}{84,428} + \frac{\text{l/min} \times \text{bar}}{511} = \text{electric motor kW}$$

When using a variable frequency drive (VFD) controller calculate the hp or kW at minimum and maximum pump speed to ensure the correct hp or kW motor is selected. Note that motor manufacturers typically de-rate the service factor to 1.0 when operating with a VFD.

See page 190 for calculating pulley size.

For technical assistance in pump selection, see Frequently Asked Questions on page 188, Design Considerations on page 189, and Installation Guidelines on pages 190-191.

D04 Series Representative Drawings

D04 Models with Metallic Pump Head Inches (mm)

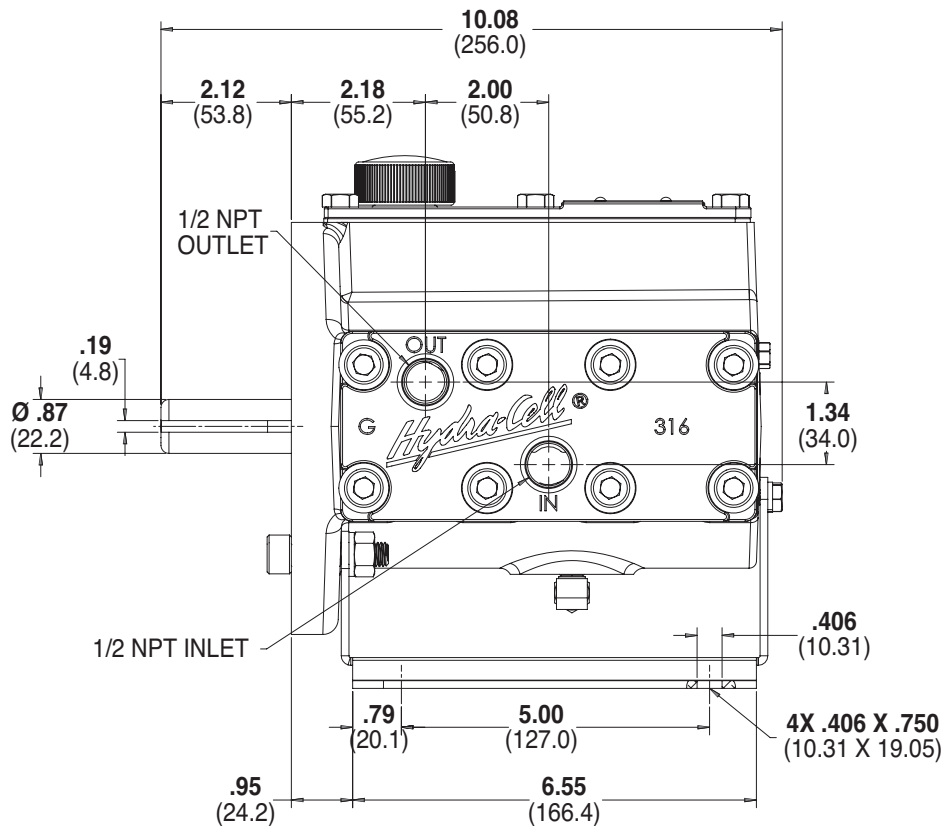
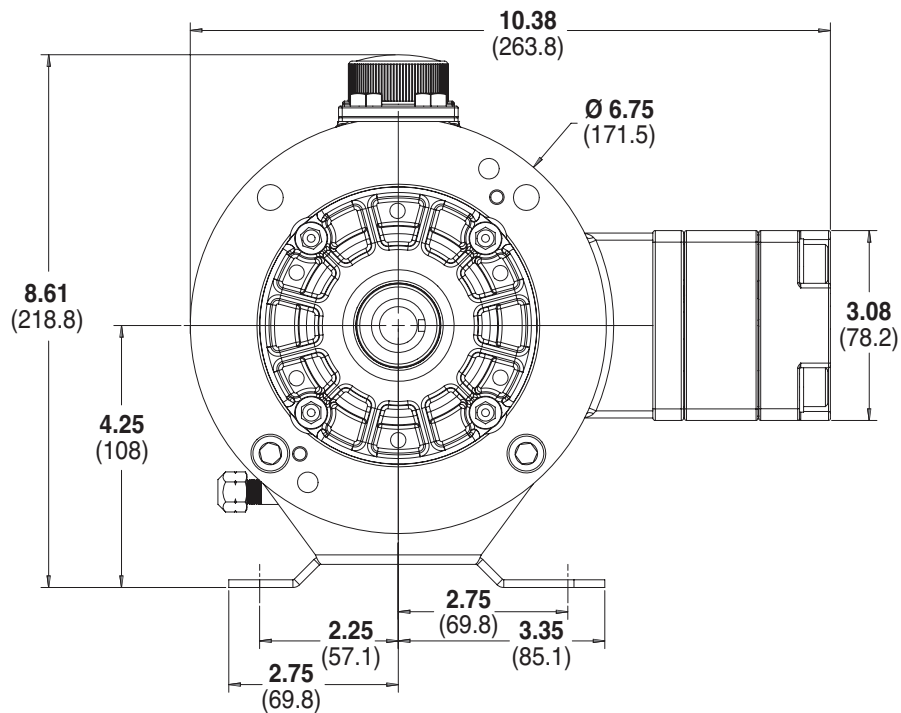

Note: Dimensions are for reference only. Contact factory for certified drawings.

D04 Series **Adapters/Valves**

Pump/Motor Adapter Inches (mm)

Part Number: A04-001-I202

Must be ordered separately for D04 models for use with 56C, I43TC and I45TC frame motors.

Metric adapter available - consult factory.

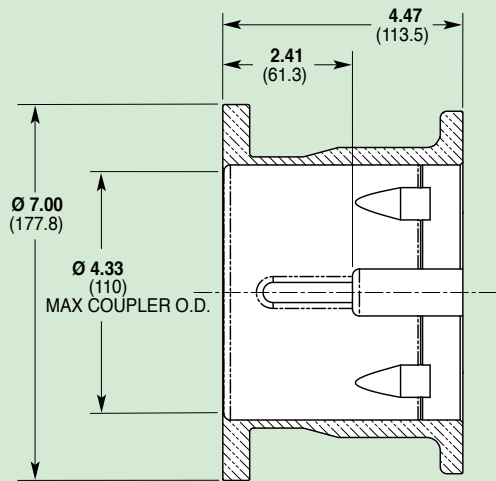

Part Number: A04-002-I202

Must be ordered separately for D04 models for use with I82TC, I84TC, 2I3TC and 2I5TC frame motors.

Metric adapter available - consult factory.

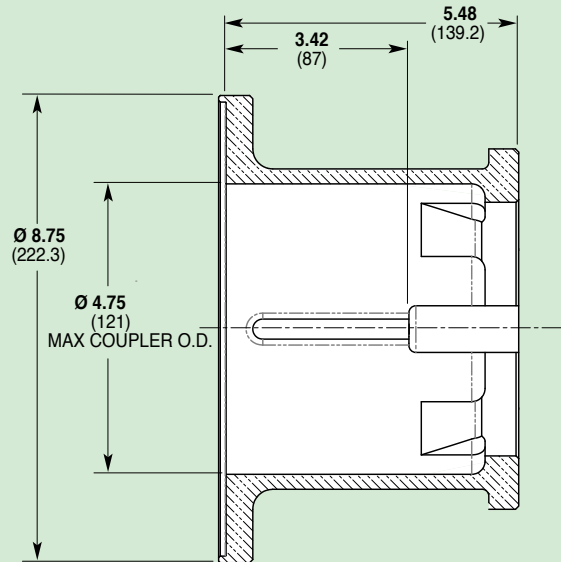

Valve Selection

A seal-less C62 Pressure Regulating Valve is recommended for Hydra-Cell D04 pumping systems, especially for high-pressure requirements or when handling dirty fluids.

See page 88 for more information.



D04 Series **How to Order**

Ordering Information



A complete D04 Series Model Number contains 12 digits including 8 customer-specified design and materials options, for example: D04SABTHFECC.

Digit	Order Code	Description
1-3	D04	Pump Configuration Shaft-driven (NPT Ports)* *Pump/motor adapters ordered separately. See previous page.
4	X	Hydraulic End Cam Max 2.9 gpm (11.2 l/min) @ 1750 rpm
	E	Max 2.0 gpm (7.7 l/min) @ 1750 rpm
	S	Max 1.6 gpm (6.2 l/min) @ 1750 rpm
5	A	Pump Head Version NPT Ports
6	B	Pump Head Material Brass
	R	304 Stainless Steel
	S	316L Stainless Steel
	T	Hastelloy C
7	E	Diaphragm & O-ring Material EPDM (requires EPDM-compatible oil - Digit 12 oil code J)
	G	FKM
	J	PTFE
	P	Neoprene
	T	Buna-N
8	D	Valve Seat Material Tungsten Carbide
	H	17-4 Stainless Steel
	N	Nitronic
	T	Hastelloy C
9	D	Valve Material Tungsten Carbide
	F	17-4 Stainless Steel
	N	Nitronic 50
	T	Hastelloy C
10	E	Valve Springs Elgiloy
	S	316L Stainless Steel
	T	Hastelloy C

Digit	Order Code	Description
11		Valve Spring Retainers
	C	Celcon
	H	17-7 Stainless Steel
	M	PVDF
	P	Polypropylene
	T	Hastelloy C
	Y	Nylon
12		Hydra-Oil
	G	5W30 cold-temp severe-duty synthetic oil
	J	EPDM-compatible oil
	K	Food-contact oil

Note: For motors, bases, couplings and other pump accessories, refer to the Accessories section beginning on page 92.

D10 Series

Maximum Flow Rate: 8.8 gpm (33.4 l/min)

Maximum Pressure: 1500 psi (103 bar) for Metallic Pump Heads
350 psi (24 bar) for Non-metallic Pump Heads

**Now Featuring Optimized
Valve Plate for Improved
Performance, Pump
Safety & Reliability.**

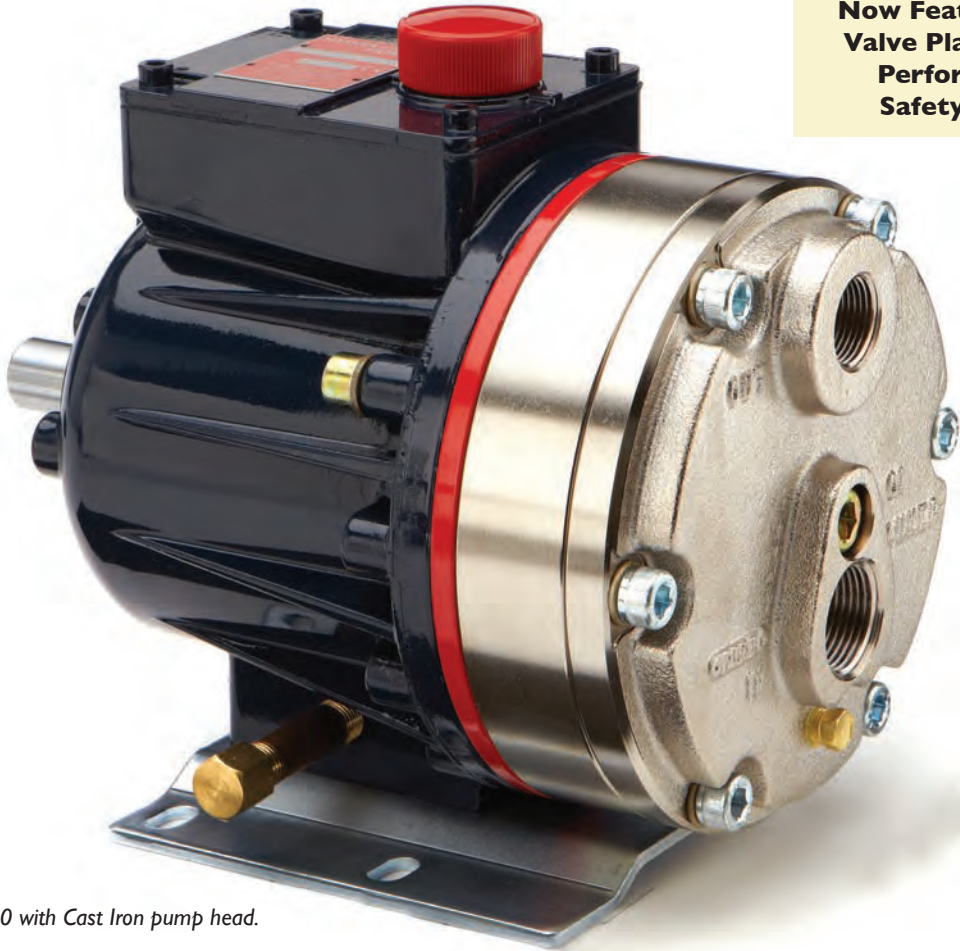

D10 with Cast Iron pump head.



D10 with Brass pump head.



D10 with Polypropylene pump head.



*D10 with 316L Stainless Steel pump head
and ANSI flanges.*

D10 Series Performance

Capacities

Flow

Model	Max. Input rpm	Max. Flow	
		@ 1000 psi (69 bar) gpm	l/min
D10-X	1450	8.1	30.6
D10-E	1750	8.8	33.4
D10-S	1750	6.0	22.7
D10-I	1750	4.0	15.0
@ 1500 psi (103 bar)			
D10-X	790	4.26	15.1
D10-E	790	3.87	14.7

Pressure

Maximum Inlet Pressure

250 psi (17 bar)

Maximum Discharge Pressure

Metallic Pump Heads:

D10-X, E, S, I to 1000 psi (69 bar)

D10-X to 1500 psi (103 bar) @ 790 rpm max.

Non-metallic Pump Heads:

250 psi (17 bar) Polypropylene

350 psi (24 bar) PVDF

Performance and specification ratings apply to D10 configurations unless specifically noted otherwise.

Maximum Flow at Designated Pressure

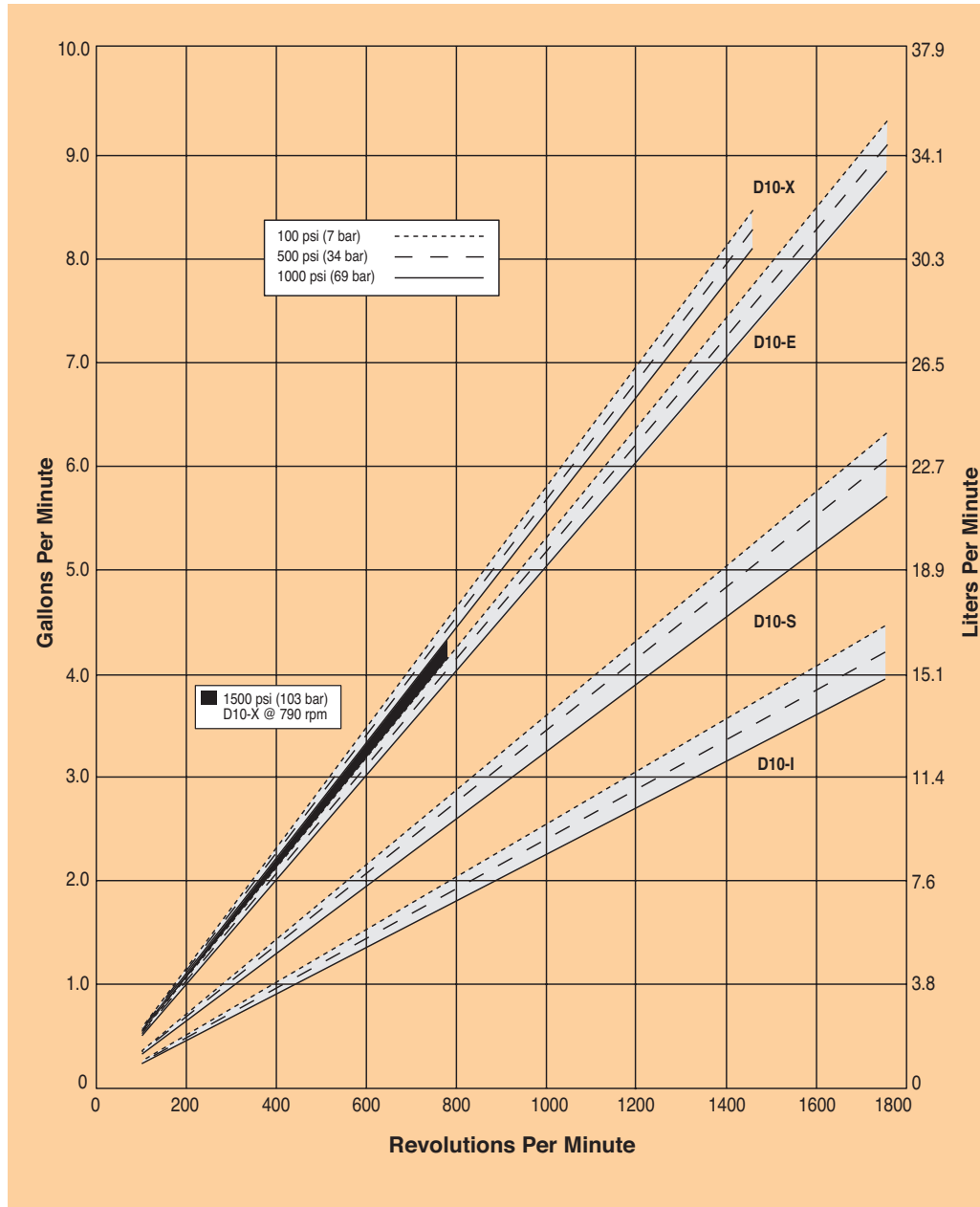

D10 Series Specifications

Flow Capacities @1000 psi (69 bar)

Model	rpm	gpm	l/min
D10-X	1450	8.10	30.6
D10-E	1750	8.83	33.4
D10-S	1750	6.00	22.7
D10-I	1750	3.96	15.0

Delivery @1500 psi (103 bar)

Model	gal/rev	liters/rev
D10-X	0.0054	0.0205
D10-E	0.0049	0.0186

Delivery @1000 psi (69 bar)

Model	gal/rev	liters/rev
D10-X	0.0056	0.0211
D10-E	0.0051	0.0191
D10-S	0.0034	0.0130
D10-I	0.0023	0.0086

Maximum Discharge Pressure

Metallic Heads:	1000 psi (69 bar) @1450 rpm (D10-X)
	1000 psi (69 bar) @1750 rpm (D10-E, S, I)
	1500 psi (103 bar) @790 rpm (D10-X)
Non-metallic Heads:	250 psi (17 bar) Polypropylene
	350 psi (24 bar) PVDF

Maximum Inlet Pressure 250 psi (17 bar)

Maximum Operating Temperature

Metallic Heads:	250 °F (121 °C) - Consult factory for correct component selection for temperatures from 160 °F (71 °C) to 250 °F (121 °C).
Non-metallic Heads:	140 °F (60 °C)

Maximum Solids Size 500 microns

Inlet Port	1 inch NPT
	150lb ANSI RF flange

Discharge Port	3/4 inch NPT
	600lb ANSI RF flange

Shaft Diameter	7/8 inch (22.2 mm)
----------------	--------------------

Shaft Rotation	Reverse (bi-directional)
----------------	--------------------------

Bearings	Tapered roller bearings
----------	-------------------------

Oil Capacity	1.1 US quarts (1.05 liters) - See pages 100 and 101 for oil selection and specification.
--------------	--

Weight

Metallic Heads:	48 lbs. (21.8 kg)
Non-metallic Heads:	35 lbs. (15.9 kg)

Net Positive Suction Head (NPSHr)

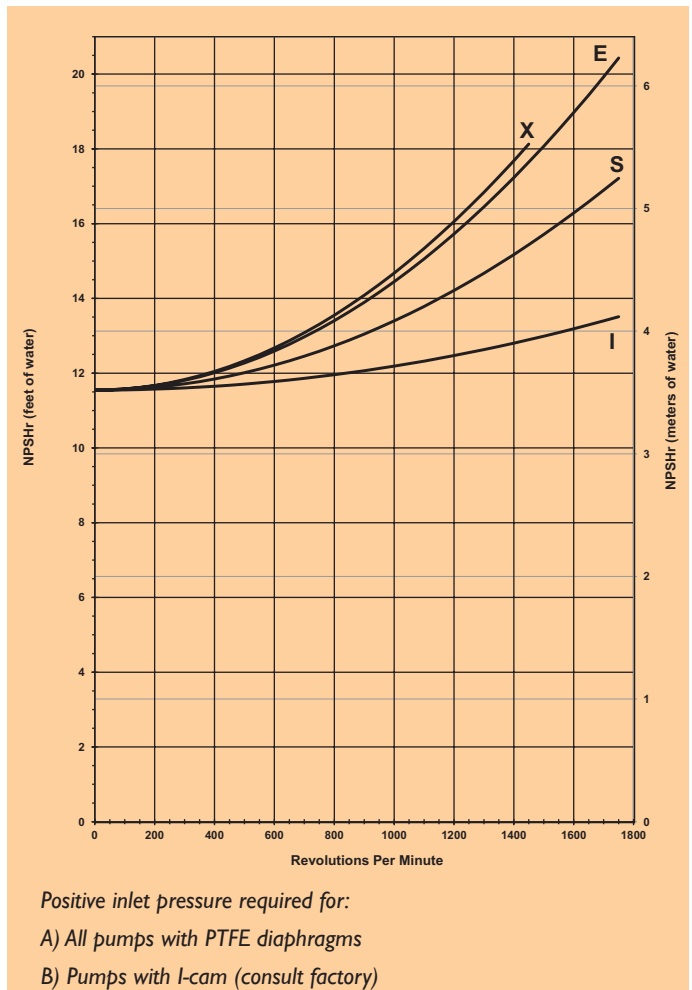

Suction Lift:

Each Hydra-Cell pump has different lift capability depending on model size, cam angle, speed, and fluid characteristics. To ensure that your specific lift characteristics are met, refer to the inlet calculations regarding friction, and acceleration head losses in your Hydra-Cell Installation & Service Manual. Compare those calculations to the NPSHr curves above.

Calculating Required Power

$$\frac{15 \times \text{rpm}}{63,000} + \frac{\text{gpm} \times \text{psi}}{1,460} = \text{electric motor hp}$$

$$\frac{15 \times \text{rpm}}{84,428} + \frac{\text{l/min} \times \text{bar}}{511} = \text{electric motor kW}$$

When using a variable frequency drive (VFD) controller calculate the hp or kW at minimum and maximum pump speed to ensure the correct hp or kW motor is selected. Note that motor manufacturers typically de-rate the service factor to 1.0 when operating with a VFD.

See page 190 for calculating pulley size.

For technical assistance in pump selection, see Frequently Asked Questions on page 188, Design Considerations on page 189, and Installation Guidelines on pages 190-191.

D10 Series Representative Drawings

D10 Models with Metallic Pump Head Inches (mm)

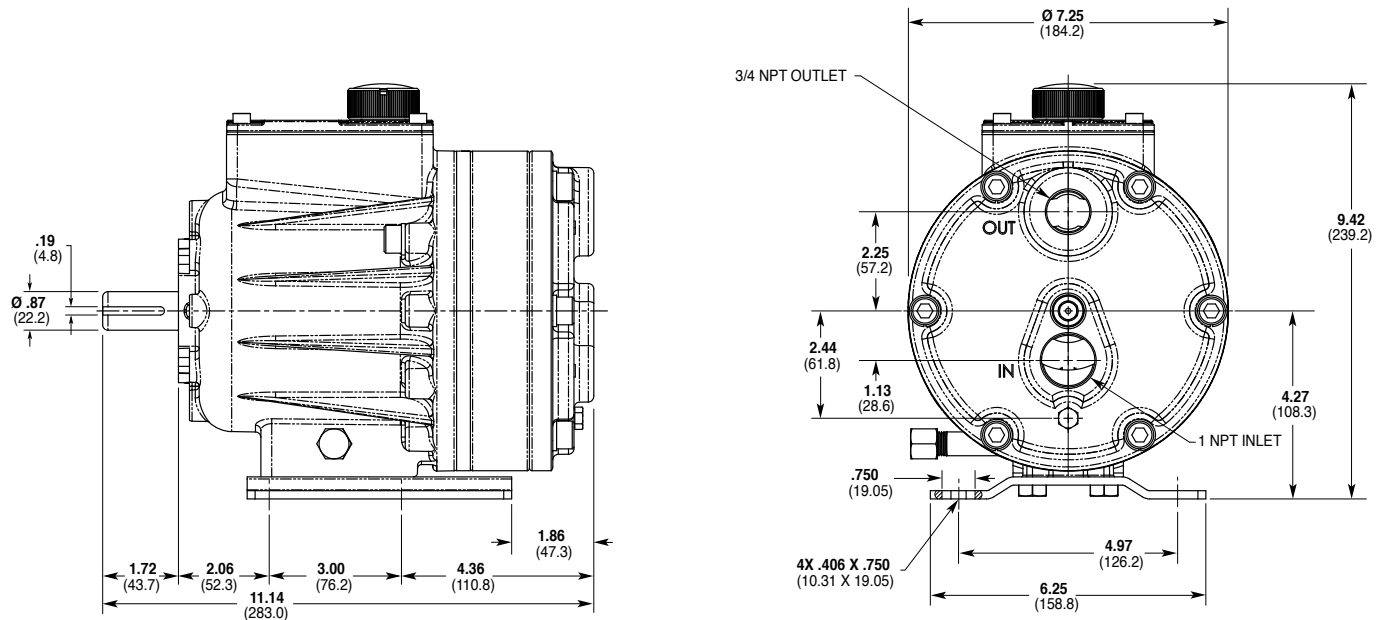

D10 Models with Non-metallic Pump Head Inches (mm)

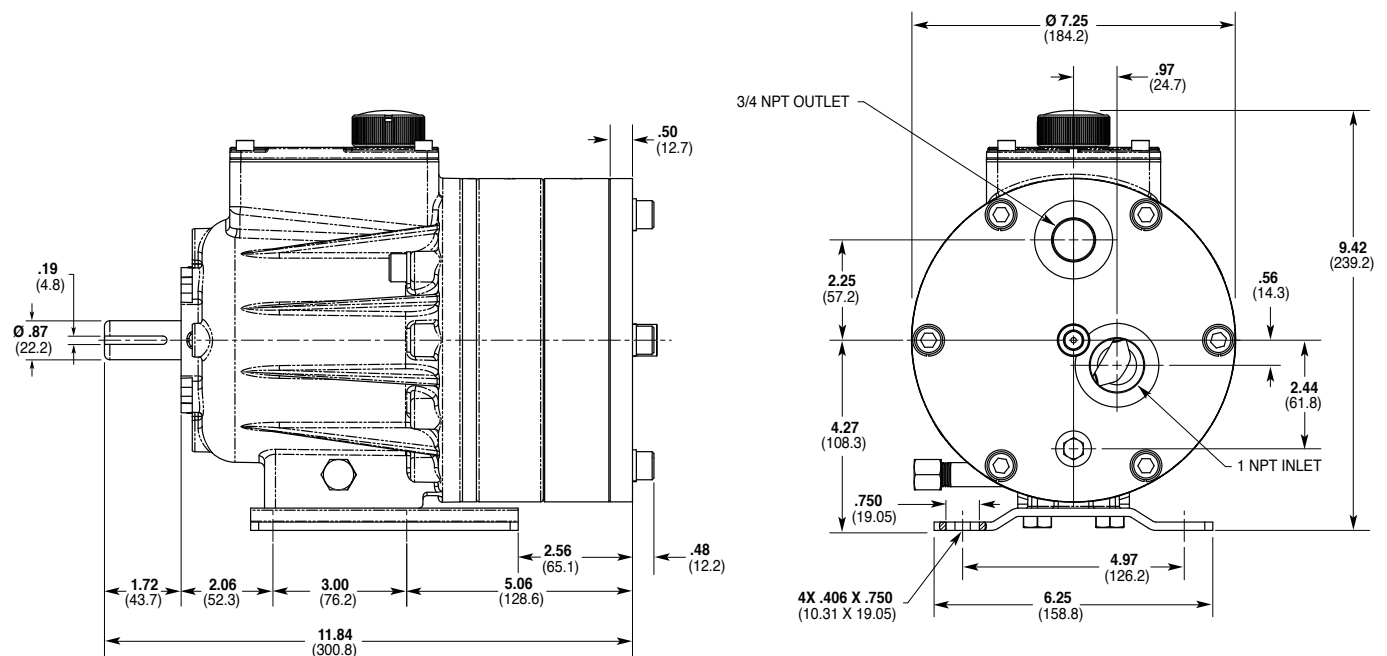

Note: Dimensions are for reference only. Contact factory for certified drawings.

D10 Series **Adapters/Valves/Skids**

Pump/Motor Adapter Inches (mm)

Part Number: A04-001-I200

For: 56C, I43TC and I45TC frame motors.

Metric adapter available - consult factory.

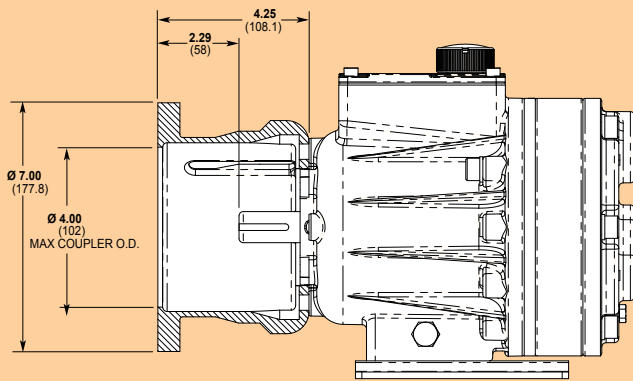

Part Number: A04-002-I200

For: I82TC, I84TC, 2I3TC and 2I5TC frame motors.

Metric adapter available - consult factory.

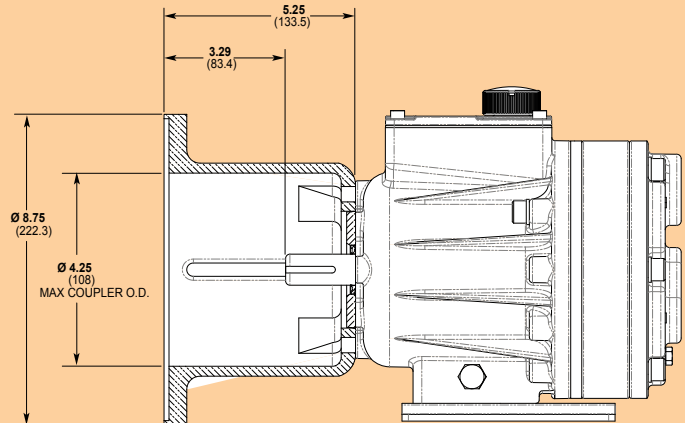

Valve Selection

A seal-less C62 Pressure Regulating Valve is recommended for Hydra-Cell D10 pumping systems, especially for high-pressure requirements or when handling dirty fluids.

See page 88 for more information.



A C22 Pressure Regulating Valve provides a capable, lower-cost alternative to C62 valves for Hydra-Cell D10 pumping systems.

See page 84 for more information.



Skid-mounted D10 with 3hp, 3-phase motor.

D10 Series **How to Order**

Ordering Information



A complete D10 Series Model Number contains 12 digits including 9 customer-specified design and materials options, for example: D10XKBTHFECA.

Digit	Order Code	Description
1-3	D10	Pump Configuration Shaft-driven (NPT Ports or ANSI Flanges)* *Pump/motor adapters ordered separately. See previous page.
4	X E S I	Hydraulic End Cam Max 8.1 gpm (30.6 l/min) @ 1450 rpm Max 8.8 gpm (33.4 l/min) @ 1750 rpm Max 6.0 gpm (22.7 l/min) @ 1750 rpm Max 4.0 gpm (15.0 l/min) @ 1750 rpm
5	K R	Pump Head Version Kel-Cell NPT Ports Kel-Cell NPT Ports with Optimized Valve Pocket
6	B C G M N P R S T	Pump Head Material Brass Cast Iron (Nickel-plated) Duplex Alloy 2205 Stainless Steel (with Hastelloy C followers & follower screws) PVDF (with Hastelloy C followers & follower screws) Polypropylene (with Hastelloy C followers & follower screws) Polypropylene (with 316L Stainless Steel followers & follower screws) 316L Stainless Steel ANSI flange class 150 x 600 316L Stainless Steel Hastelloy CW12MW
7	A E G J P T	Diaphragm & O-ring Material Aflas diaphragm / PTFE o-ring EPDM (requires EPDM-compatible oil - Digit 12 oil code C) FKM PTFE (available with E and S cams only; 1200 rpm max.) Neoprene Buna-N
8	C D H S T	Valve Seat Material Ceramic Tungsten Carbide 17-4 Stainless Steel 316L Stainless Steel Hastelloy C

Digit	Order Code	Description
9	C D F N T	Valve Material Ceramic Tungsten Carbide 17-4 Stainless Steel Nitronic 50 Hastelloy C
10	E H T	Valve Springs Elgiloy 17-7 Stainless Steel Hastelloy C
11	C H M P T Y	Valve Spring Retainers Celcon 17-7 Stainless Steel (used with metallic heads only) PVDF Polypropylene Hastelloy C (used with metallic heads only) Nylon (Zytel)
12	A B C E G H	Hydra-Oil 10W30 standard-duty oil 40-wt for continuous-duty oil (use with 316L SST or Hastelloy CW12MW pump head - standard) EPDM-compatible oil Food-contact oil 5W30 cold-temp severe-duty synthetic oil 15W50 high-temp severe-duty synthetic oil

D10 Pump Housing is standard as Cast Aluminum. Upgrade to Ductile Iron available.

Note: For motors, bases, couplings and other pump accessories, refer to the Accessories section beginning on page 92.

D12 Series

Maximum Flow Rate: 8.8 gpm (33.4 l/min)

Maximum Pressure: 1000 psi (69 bar) for Metallic Pump Heads

**Now Featuring Optimized
Valve Plate for Improved
Performance, Pump
Safety & Reliability.**



D12 equipped with Model C62 Pressure Regulating Valve and Valve/Tube Accessory, shown with Cast Iron pump head.

D12 Series Performance

Capacities

Flow

model	Max. Input rpm	Max. Flow @ 1000 psi (69 bar)	
		gpm	l/min
D12-X	1450	8.1	30.6
D12-E	1750	8.8	33.4
D12-S	1750	6.0	22.7
D12-I	1750	4.0	15.0

Pressure

Maximum Inlet Pressure
250 psi (17 bar)

Maximum Discharge Pressure
1000 psi (69 bar)

Performance and specification ratings apply to D12 configurations unless specifically noted otherwise.

Maximum Flow at Designated Pressure

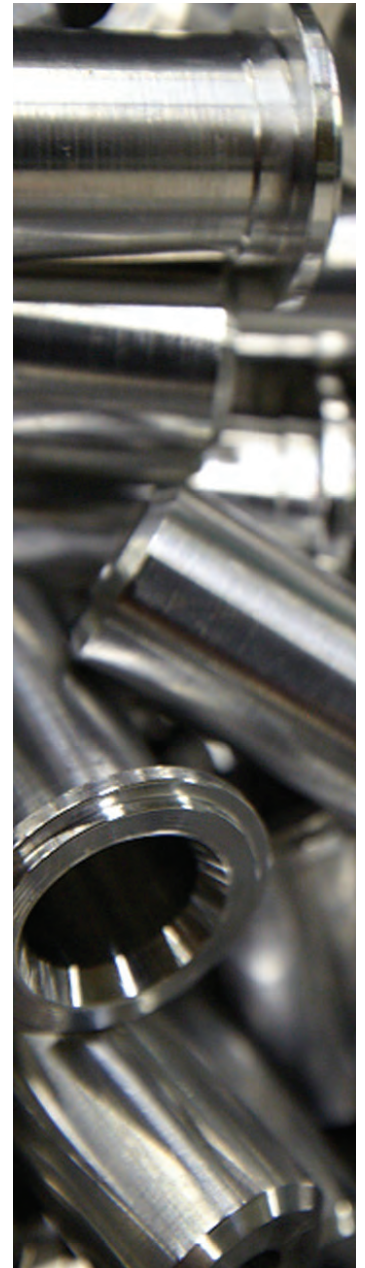
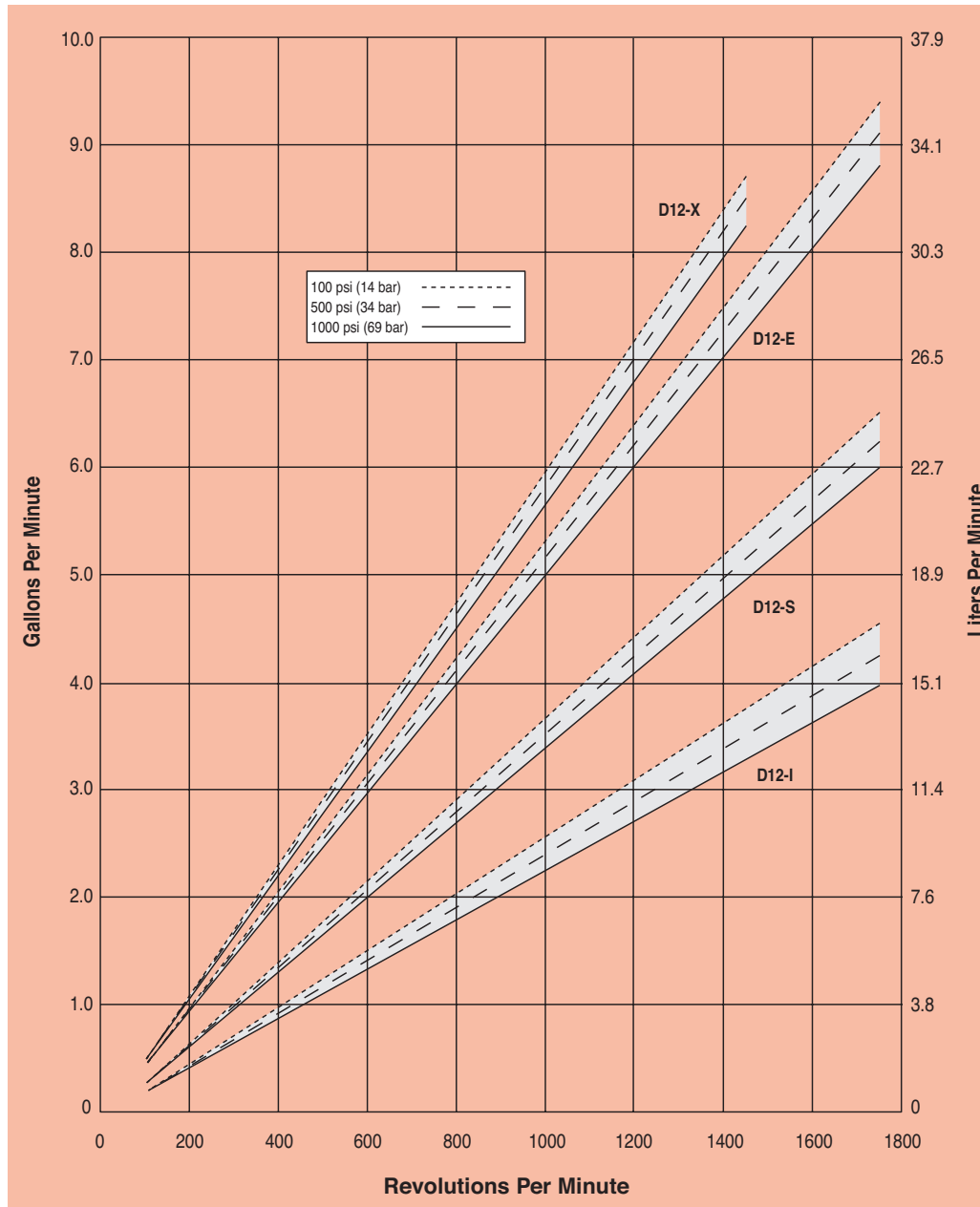

D12 Series Specifications

Flow Capacities @1000 psi (69 bar)

Model	rpm	gpm	l/min
D12-X	1450	8.10	30.6
D12-E	1750	8.83	33.4
D12-S	1750	6.00	22.7
D12-I	1750	3.96	15.0

Delivery @1000 psi (69 bar)

Model	gal/rev	liters/rev
D12-X	0.0056	0.0211
D12-E	0.0051	0.0191
D12-S	0.0034	0.0130
D12-I	0.0023	0.0086

Maximum Discharge Pressure

Metallic Heads: 1000 psi (69 bar)

Maximum Inlet Pressure

250 psi (17 bar)

Maximum Operating Temperature

Metallic Heads: 250 °F (121 °C) - Consult factory for correct component selection for temperatures from 160 °F (71 °C) to 250 °F (121 °C).

Maximum Solids Size

500 microns

Inlet Port

1 inch NPT

Discharge Port

3/4 inch NPT

Shaft Diameter

7/8 inch (22.2 mm)

Shaft Rotation

Reverse (bi-directional)

Bearings

Tapered roller bearings

Oil Capacity

1.5 US quarts (1.4 liters) - See pages 100 and 101 for oil selection and specification.

Weight

Metallic Heads: 63 lbs. (28.6 kg)

Net Positive Suction Head (NPSHr)

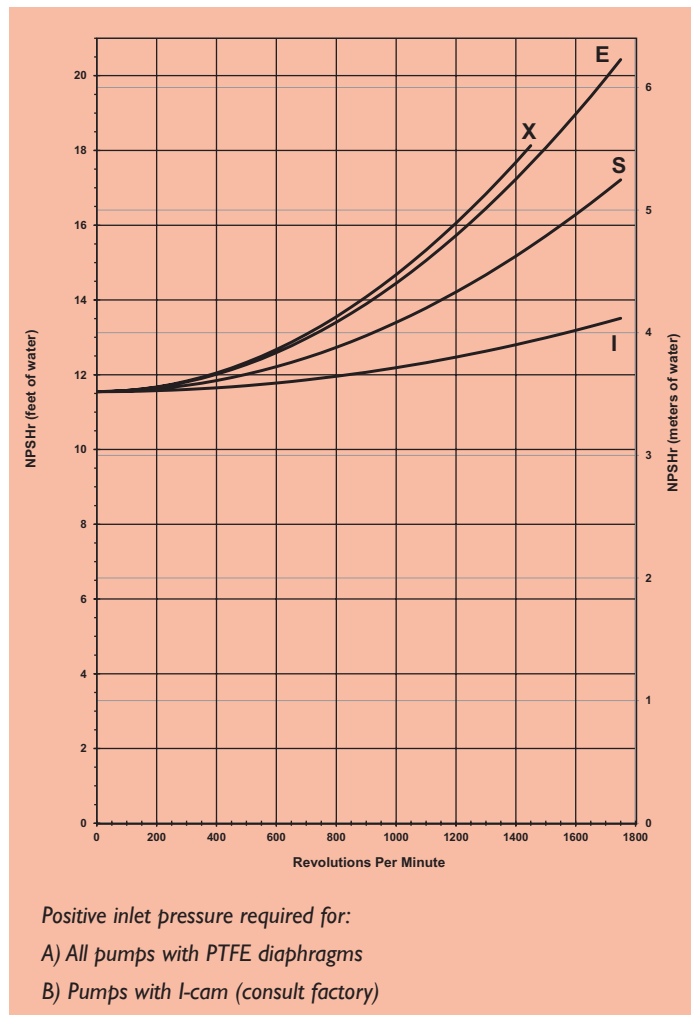

Suction Lift:

Each Hydra-Cell pump has different lift capability depending on model size, cam angle, speed, and fluid characteristics. To ensure that your specific lift characteristics are met, refer to the inlet calculations regarding friction, and acceleration head losses in your Hydra-Cell Installation & Service Manual. Compare those calculations to the NPSHr curves above.

Calculating Required Power

$$\frac{15 \times \text{rpm}}{63,000} + \frac{\text{gpm} \times \text{psi}}{1,460} = \text{electric motor hp}$$

$$\frac{15 \times \text{rpm}}{84,428} + \frac{\text{l/min} \times \text{bar}}{511} = \text{electric motor kW}$$

When using a variable frequency drive (VFD) controller calculate the hp or kW at minimum and maximum pump speed to ensure the correct hp or kW motor is selected. Note that motor manufacturers typically de-rate the service factor to 1.0 when operating with a VFD.

For technical assistance in pump selection, see Frequently Asked Questions on page 188, Design Considerations on page 189, and Installation Guidelines on pages 190-191.

DI2 Series Representative Drawings

DI2 Standard Configuration (Metallic Pump Head) Inches (mm)

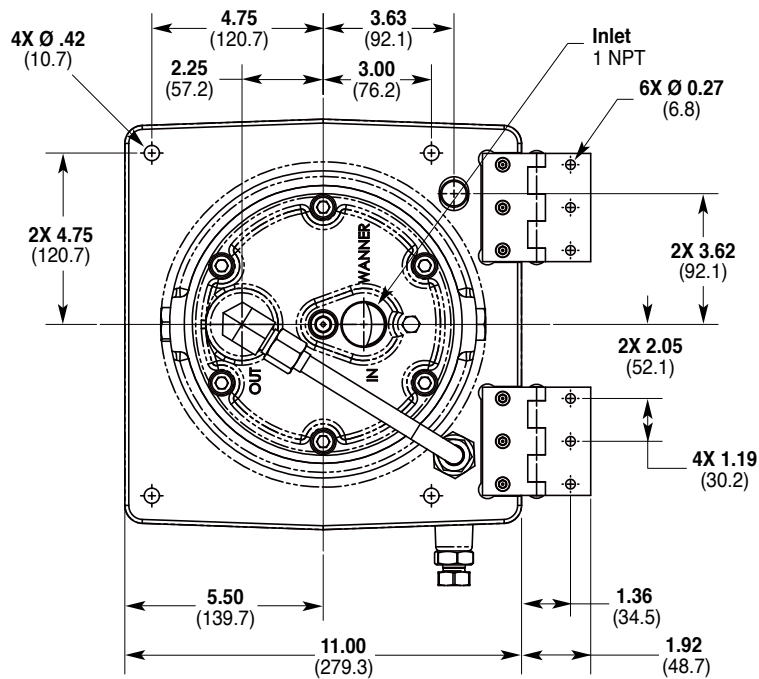
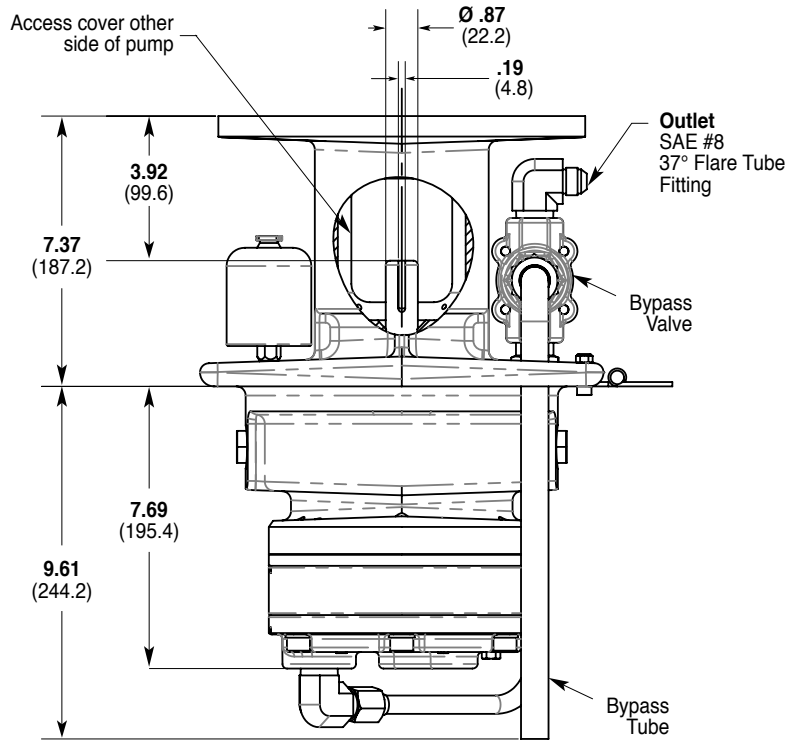

Note: Dimensions are for reference only. Contact factory for certified drawings.

DI2 Series Representative Drawings

DI2 with Tube Accessory Inches (mm)

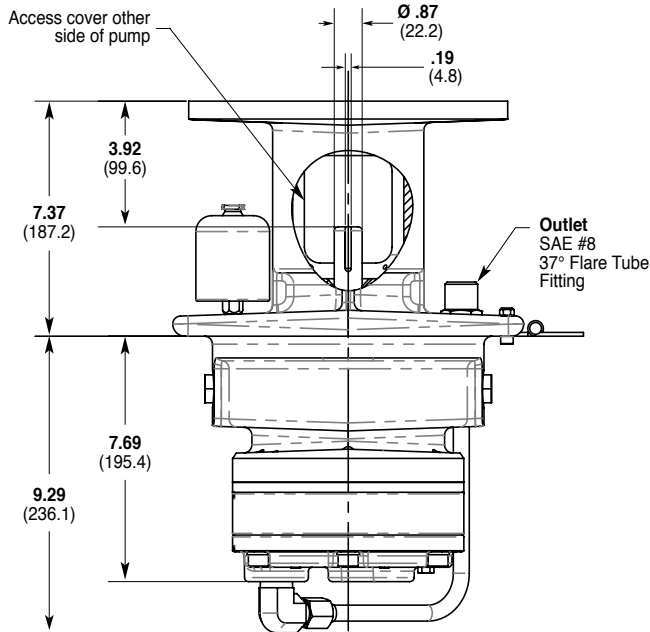

DI2 with Valve/Tube Accessory Inches (mm)

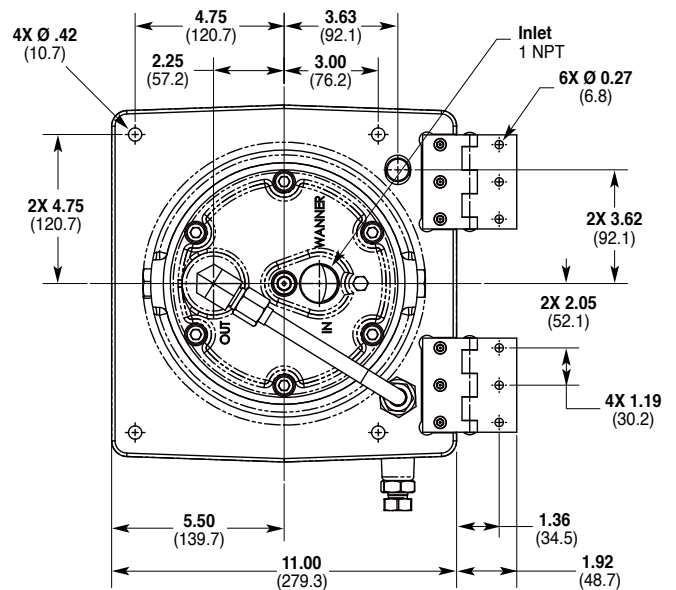
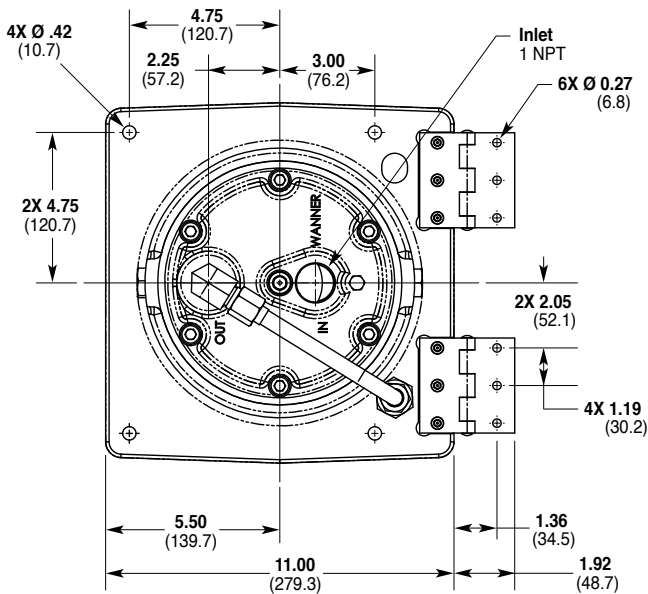
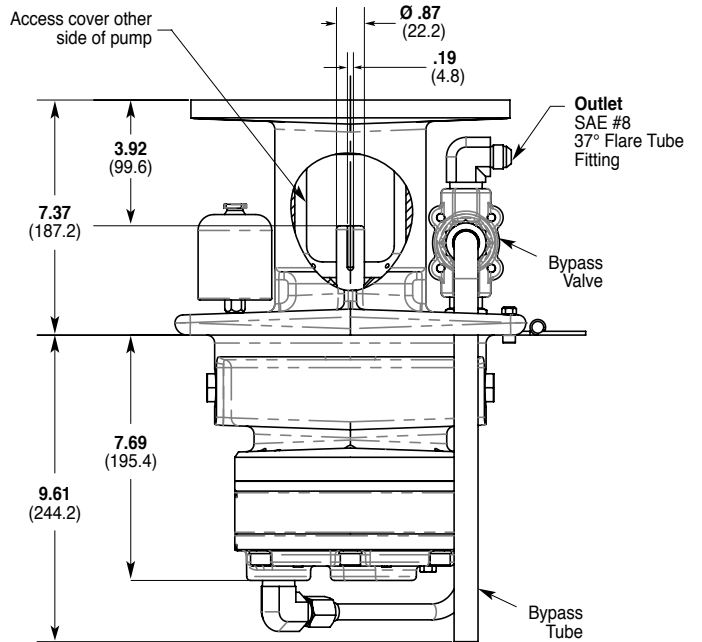

Note: Dimensions are for reference only. Contact factory for certified drawings.

D12 Series Representative Drawings

D12 Models with Minimum Tank Size and Critical Installation Dimensions Inches (mm)

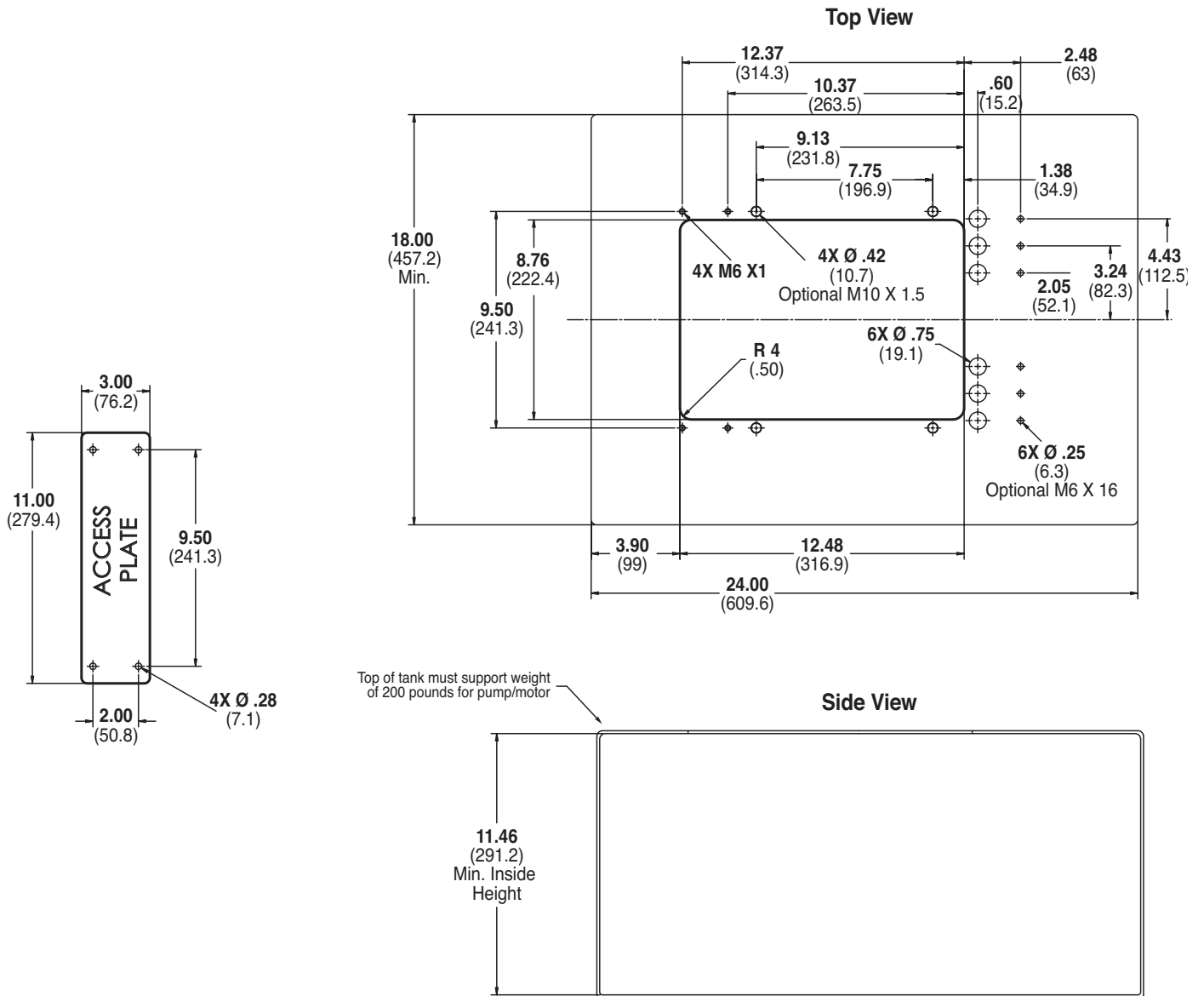

Note: Dimensions are for reference only. Contact factory for certified drawings.

D12 Series **Valve/Tube Accessories**

The Hydra-Cell D12 Tube and Valve/Tube Accessories provide a pre-fabricated plumbing package for simplified installation.
(See page 54 for dimensions.)

Ordering Information

Tube Accessory Part Number: A04-007-1200

Valve/Tube Accessory Part Number: A04-008-1200



Valve Selection

A seal-less C62 Pressure Regulating Valve is recommended for Hydra-Cell D12 pumping systems, especially for high-pressure requirements or when handling dirty fluids. See page 88 for more information.



A C22 Pressure Regulating Valve provides a capable, lower-cost alternative to C62 valves for Hydra-Cell D12 pumping systems. See page 84 for more information.



D12 Series **How to Order**

Ordering Information

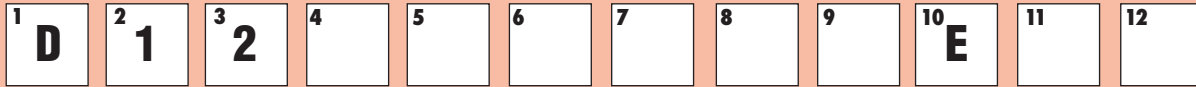

A complete D12 Series Model Number contains 12 digits including 8 customer-specified design and materials options, for example: D12XKCGHFCEA.

Digit	Order Code	Description
1-3	D12	Pump Configuration Flanged for NEMA 182/184TC, 213/215TC (NPT Ports)* *Tube Accessory Kits ordered separately. See previous page.
4	X	Hydraulic End Cam Max 8.1 gpm (30.6 l/min) @ 1450 rpm
	E	Max 8.8 gpm (33.4 l/min) @ 1750 rpm
	S	Max 6.0 gpm (22.7 l/min) @ 1750 rpm
	I	Max 4.0 gpm (15.0 l/min) @ 1750 rpm
5	K	Pump Head Version Kel-Cell NPT Ports
	R	Kel-Cell NPT Ports with Optimized Valve Pocket
6	B	Pump Head Material Brass
	C	Cast Iron (Nickel-plated)
	S	316L Stainless Steel
7	E	Diaphragm & O-ring Material EPDM (requires EPDM-compatible oil - Digit 12 oil code C)
	G	FKM
	J	PTFE (available with E and S cams only; 1200 rpm max.)
	P	Neoprene
	T	Buna-N
8	C	Valve Seat Material Ceramic
	D	Tungsten Carbide
	H	17-4 Stainless Steel
	S	316L Stainless Steel
9	C	Valve Material Ceramic
	D	Tungsten Carbide
	F	17-4 Stainless Steel
	N	Nitronic 50
10	E	Valve Springs Elgiloy

Digit	Order Code	Description
11	C	Valve Spring Retainers Celcon
	H	17-7 Stainless Steel
	M	PVDF
	P	Polypropylene
	Y	Nylon (Zytel)
12	A	Hydra-Oil 10W30 standard-duty oil
	B	40-wt for continuous-duty (use with 316L SST pump head - standard)
	C	EPDM-compatible oil
	E	Food-contact oil
	G	5W30 cold-temp severe-duty synthetic oil

Note: For motors, bases, couplings and other pump accessories, refer to the Accessories section beginning on page 92.

D15/D17 Series

Maximum Flow Rate: 15.5 gpm (58.7 l/min)

Maximum Pressure: 2500 psi (172 bar) for Metallic Pump Heads

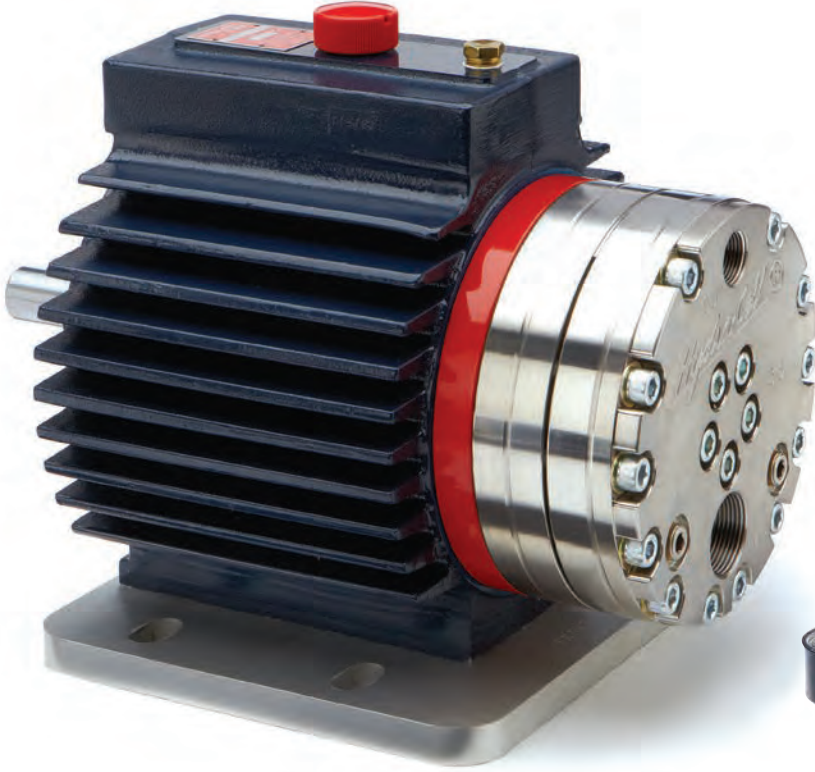

D15 for horizontal installations shown with 316L Stainless Steel pump head.



D17 for vertical mounting (including motor adapter, base plate and oil reservoir) shown with Brass pump head.

DI5/DI7 Series Performance

Capacities

Model	Max. Input rpm	Max. Flow		Max. Pressure	
		gpm	l/min	Inlet Pressure	Discharge Pressure
D15-X/D17-X	1450	13.8	52.3	500 psi (34 bar)	500 psi (34 bar)
	1450	13.3	50.2	500 psi (34 bar)	1500 psi (103 bar)
	1450	13.0	49.2	500 psi (34 bar)	2000 psi (138 bar)
	1150	10.1	38.1	500 psi (34 bar)	2500 psi (172 bar)
D15-E/D17-E	1750	15.5	58.7	500 psi (34 bar)	500 psi (34 bar)
	1750	14.8	56.2	500 psi (34 bar)	1500 psi (103 bar)
	1450	12.0	45.5	500 psi (34 bar)	2000 psi (138 bar)

Performance and specification ratings apply to DI5/DI7 configurations unless specifically noted otherwise.

Maximum Flow at Designated Pressure

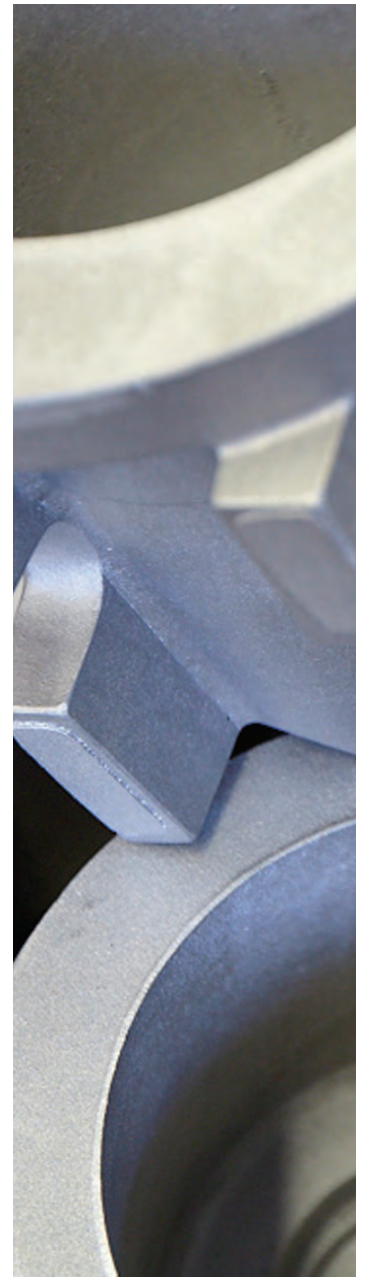
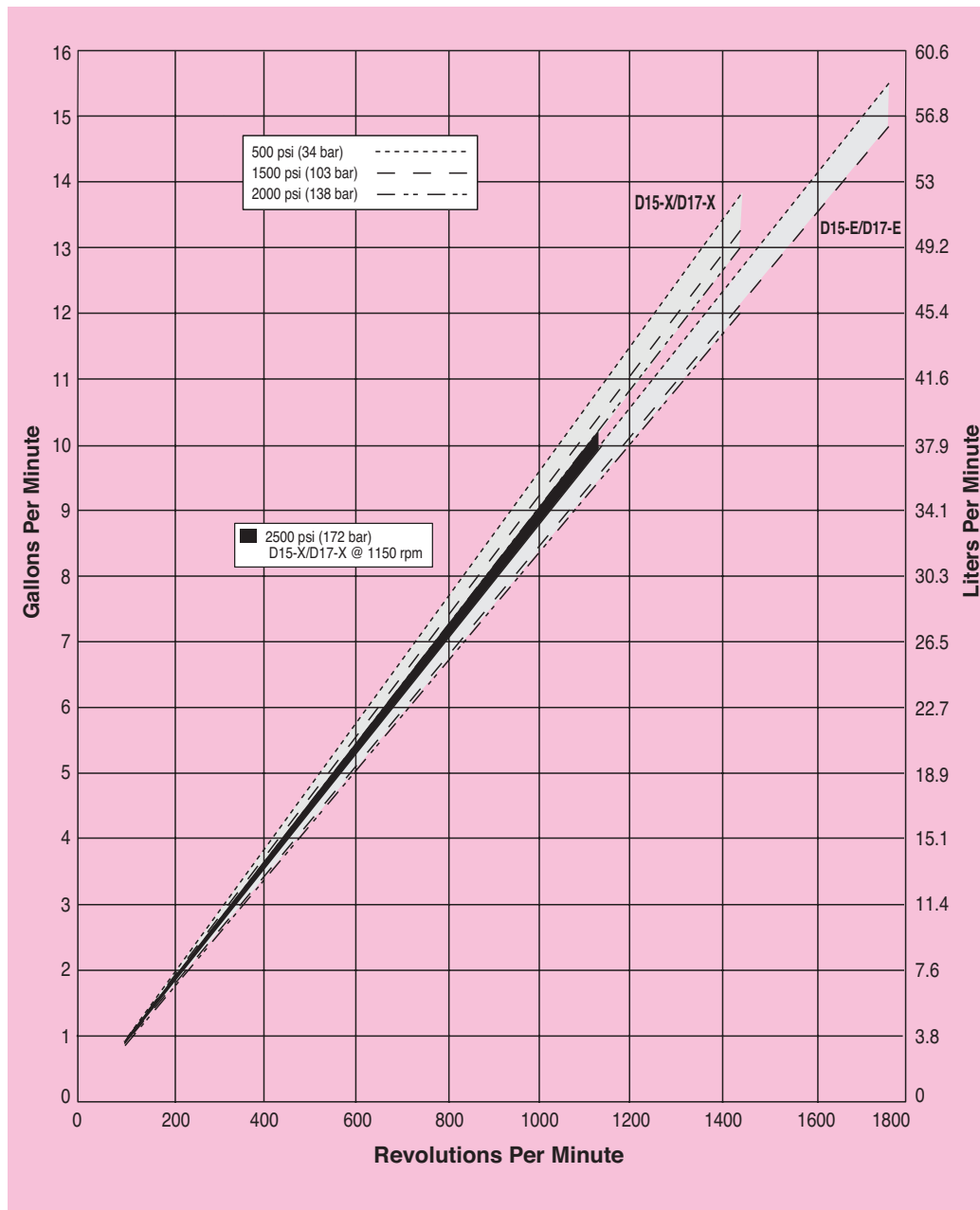

DI5/DI7 Series Specifications

Flow Capacities

Model	@ max rpm	psi	bar	gpm	l/min
DI5-X/DI7-X	1450	500	34	13.8	52.3
	1450	1500	103	13.3	50.2
	1450	2000	138	13.0	49.2
	1150	2500	172	10.1	38.1
DI5-E/DI7-E	1750	500	34	15.5	58.7
	1750	1500	103	14.8	56.2
	1450	2000	138	12.0	45.5

Delivery

Model	psi	bar	gal/rev	liters/rev
DI5-X/DI7-X	500	34	0.0095	0.0360
	1500	103	0.0092	0.0346
	2000	138	0.0090	0.0339
	2500	172	0.0088	0.0331
DI5-E/DI7-E	500	34	0.0089	0.0335
	1500	103	0.0085	0.0321
	2000	138	0.0083	0.0314

Maximum Discharge Pressure

Metallic Heads:	1500 psi (103 bar) @1750 rpm (DI5-E & DI7-E only)
	2000 psi (138 bar) @1450 rpm
	2500 psi (172 bar) @1150 rpm

Maximum Inlet Pressure

500 psi (34 bar)

Maximum Operating Temperature

Metallic Heads: 250° F (121° C) - Consult factory for correct component selection for temperatures from 160° F (71° C) to 250° F (121° C).

Maximum Solids Size

500 microns

Inlet Port

1-1/4 inch NPT

Discharge Port

3/4 inch NPT

Shaft Diameter

1-1/8 inch (28.6 mm)

Shaft Rotation

Reverse (bi-directional)

Bearings

Tapered roller bearings

Oil Capacity

2.2 US quarts (2.1 liters) - See pages 100 and 101 for oil selection and specification.

Weight

Metallic Heads: 145 lbs. (66 kg)

Calculating Required Power

$$\frac{80 \times \text{rpm}}{63,000} + \frac{\text{gpm} \times \text{psi}}{1,460 - \left(\frac{\text{psi} - 500}{20}\right)} = \text{electric motor hp}$$

$$\frac{80 \times \text{rpm}}{84,428} + \frac{\text{l/min} \times \text{bar}}{511 - \left(\frac{\text{bar} - 35}{4}\right)} = \text{electric motor kW}$$

When using a variable frequency drive (VFD) controller calculate the hp or kW at minimum and maximum pump speed to ensure the correct hp or kW motor is selected. Note that motor manufacturers typically de-rate the service factor to 1.0 when operating with a VFD.

See page 190 for calculating pulley size.

Net Positive Suction Head (NPSHr)

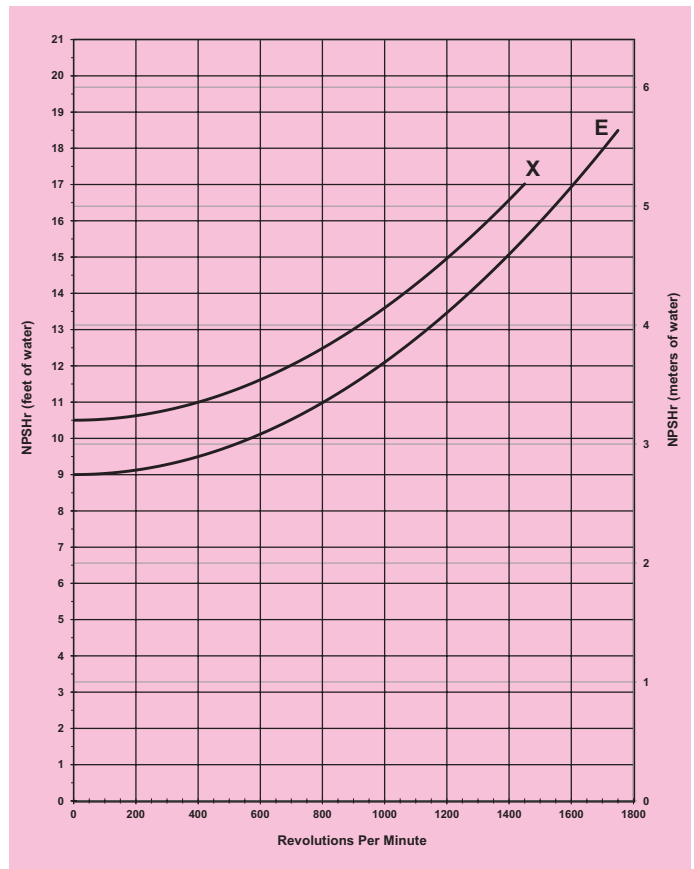

Suction Lift:

Each Hydra-Cell pump has different lift capability depending on model size, cam angle, speed, and fluid characteristics. To ensure that your specific lift characteristics are met, refer to the inlet calculations regarding friction, and acceleration head losses in your Hydra-Cell Installation & Service Manual. Compare those calculations to the NPSHr curves above.

For technical assistance in pump selection, see Frequently Asked Questions on page 188, Design Considerations on page 189, and Installation Guidelines on pages 190-191.

DI5/DI7 Series Representative Drawings

DI5 Models for Horizontal Mounting (Metallic Pump Head) Inches (mm)

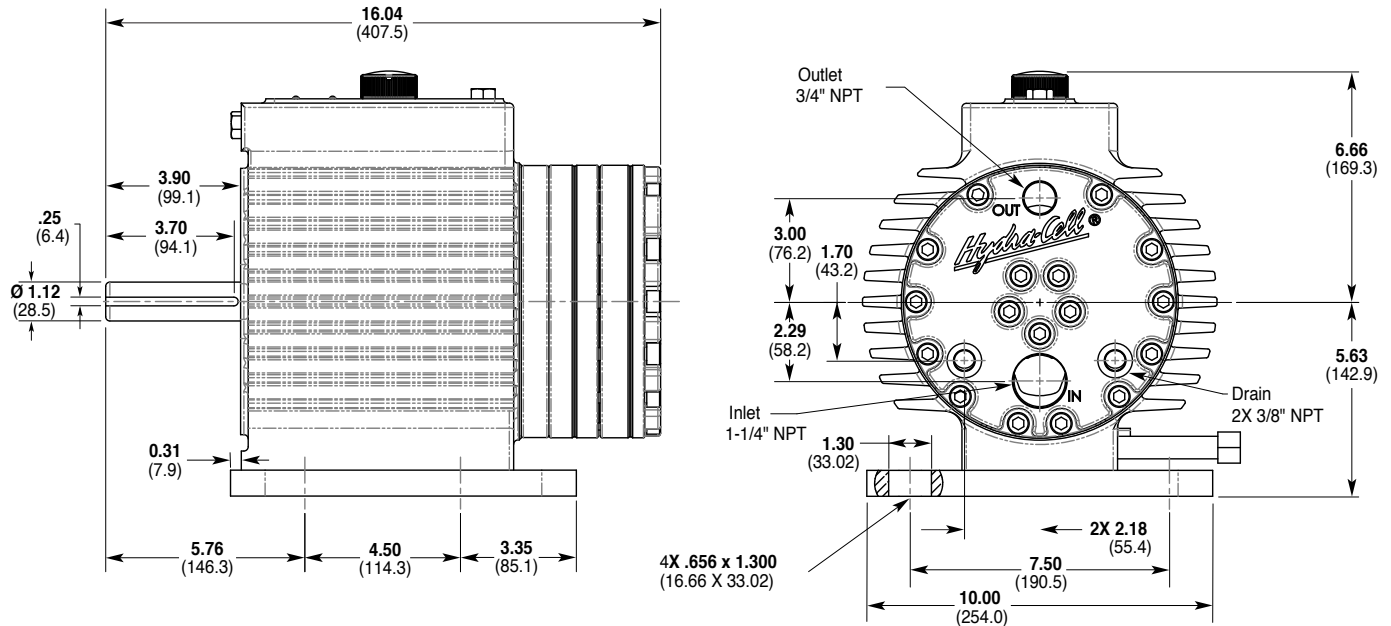

DI7 Models for Vertical Mounting (Metallic Pump Head) Inches (mm)

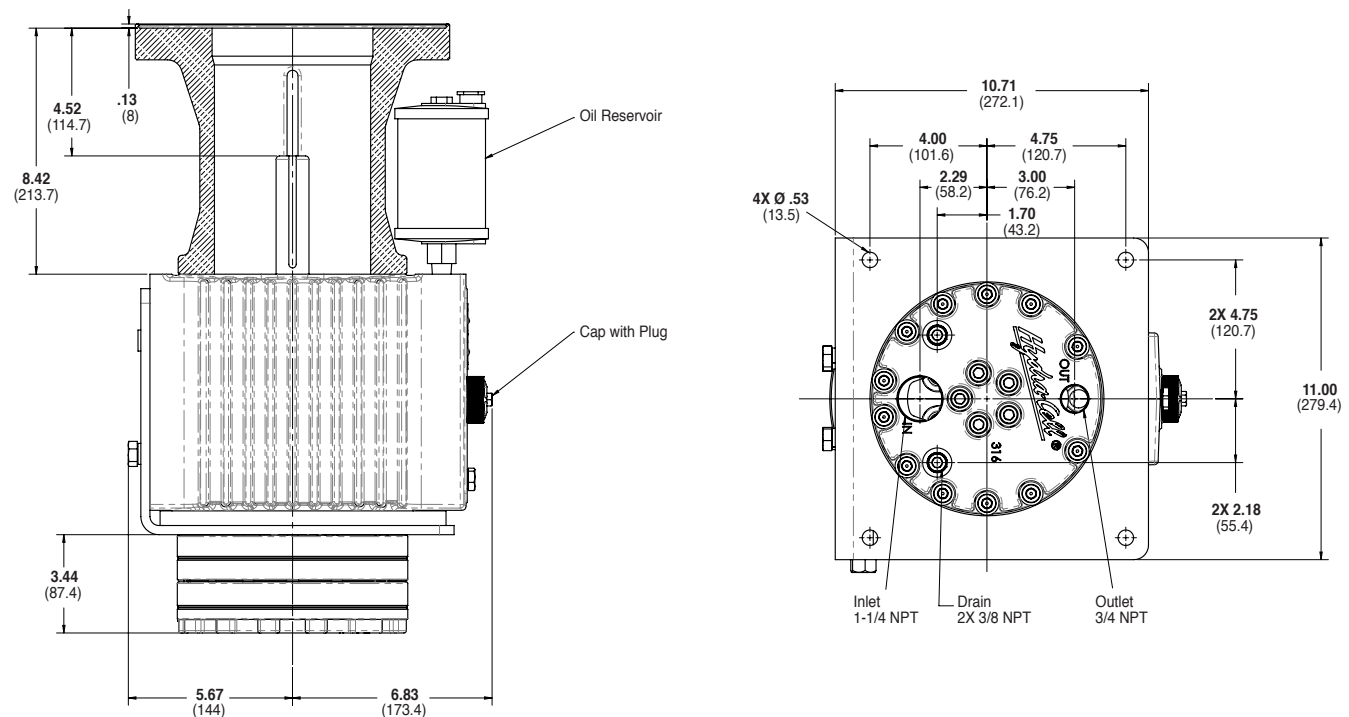

Note: Dimensions are for reference only. Contact factory for certified drawings.

DI5/DI7 Series **Adapters/Valves**

Pump/Motor Adapter Inches (mm)

Pump/Motor Adapters are designed to fit several NEMA frame sizes.

Metric adapter available - consult factory.

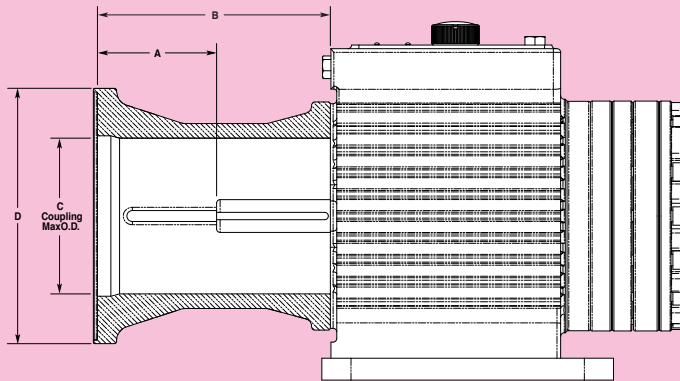

DI5 (Horizontal)

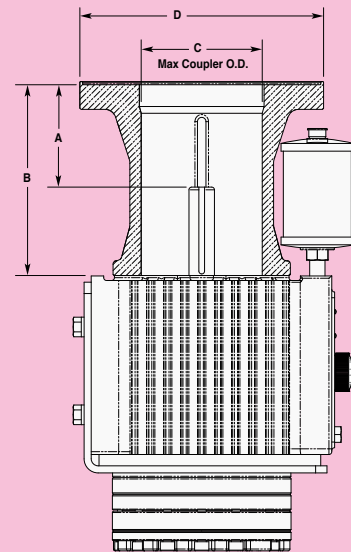

DI7 (Vertical)

Dimensions in Inches (mm)

Adapter Motor Size	Part Number	A	B	C	D
DI5/DI7 NEMA 182TC - 256TC	A04-041-1200	4.1 (103.8)	8.0 (202.8)	4.75 (120.7)	8.75 (222.3)
DI5/DI7 NEMA 284TC - 286TC	A04-041-1202	4.5 (114.7)	8.4 (213.7)	4.75 (120.7)	10.75 (273.1)

Valve Selection

A Hydra-Cell DI5/DI7 Series pumping system uses a C62 Pressure Regulating Valve.

See page 88 for more information.



D15/D17 Series **How to Order**

Ordering Information



A complete D15/D17 Series Model Number contains 12 digits including 9 customer-specified design and materials options, for example: D15XKBTHFECG.

Digit	Order Code	Description
1-3	D15	Pump Configuration Horizontal shaft-driven (NPT Ports)*
	D17	Vertical shaft-driven (NPT Ports)* *Pump/motor adapters ordered separately. See previous page.
4	X	Hydraulic End Cam Max 13.8 gpm (52.3 l/min) @ 1450 rpm
	E	Max 15.5 gpm (58.7 l/min) @ 1750 rpm
5	K	Pump Head Version Advanced Diaphragm Position Control (ADPC)
6	B	Pump Head Material Brass
	S	316L Stainless Steel
	T	Hastelloy C
7		Diaphragm & O-ring Material
	A	Aflas diaphragm/PTFE o-ring
	G	FKM
	P	Neoprene
	T	Buna-N
8		Valve Seat Material
	D	Tungsten Carbide
	H	17-4 Stainless Steel
	N	Nitronic 50
	T	Hastelloy C
9		Valve Material
	D	Tungsten Carbide
	F	17-4 Stainless Steel
	N	Nitronic 50
	T	Hastelloy C
10		Valve Springs
	E	Elgiloy
	H	17-7 Stainless Steel (high-viscosity option - requires 50 psi/3.4 bar suction pressure)
	T	Hastelloy C

Digit	Order Code	Description
11		Valve Spring Retainers
	C	Celcon
	H	17-7 Stainless Steel
	M	PVDF
	P	Polypropylene
	T	Hastelloy C
12	Y	Nylon (Zytel)
		Hydra-Oil
	A	10W30 standard-duty oil
	B	40-wt for continuous-duty (use with 316L SST pump head - standard)
	E	Food-contact oil
G	5W30 cold-temp severe-duty synthetic oil	
H	15W50 high-temp severe-duty synthetic oil	

Note: For motors, bases, couplings and other pump accessories, refer to the Accessories section beginning on page 92.

H25 Series

Maximum Flow Rate: 20.0 gpm (75.9 l/min)

Maximum Pressure: 1000 psi (69 bar) for Metallic Pump Heads
350 psi (24 bar) for Non-metallic Pump Heads

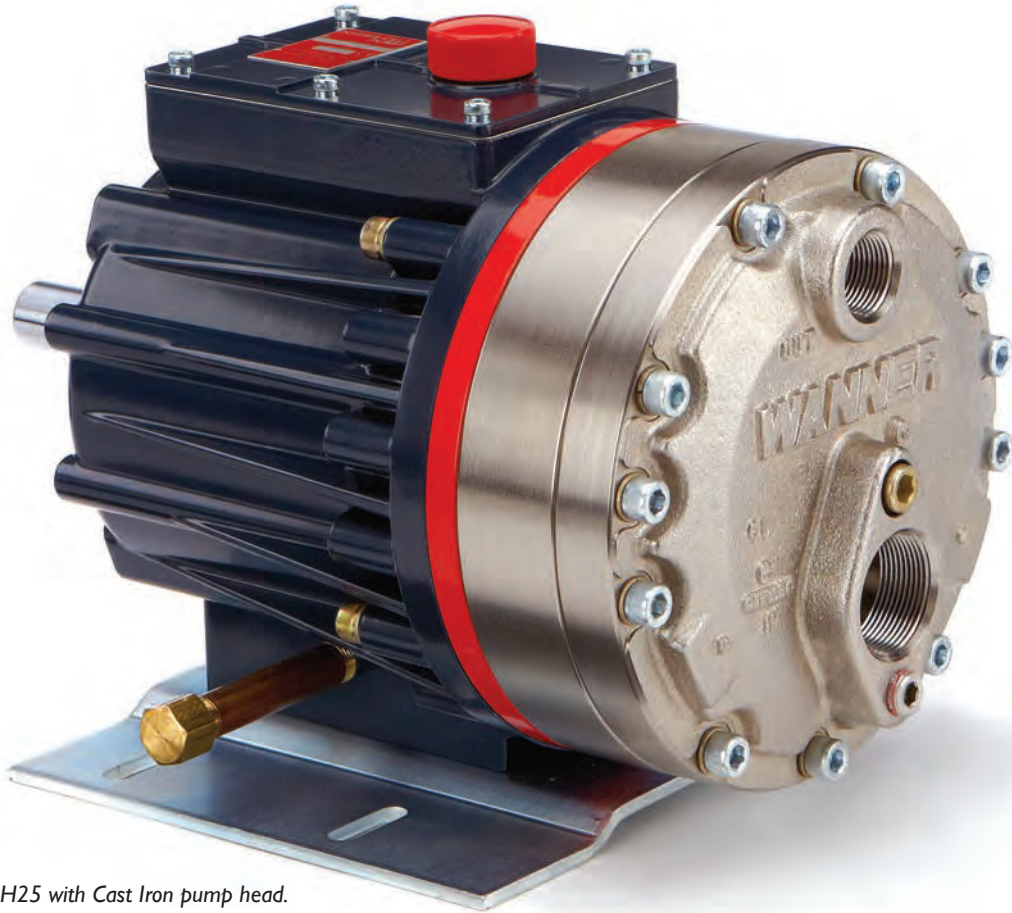

H25 with Cast Iron pump head.



H25 with Brass pump head.

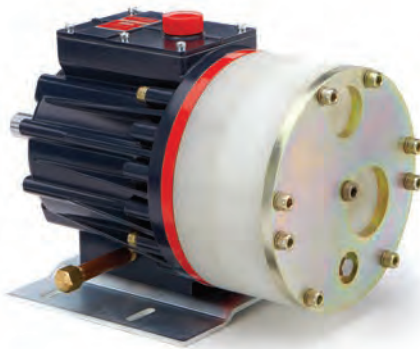

H25 with Polypropylene pump head.

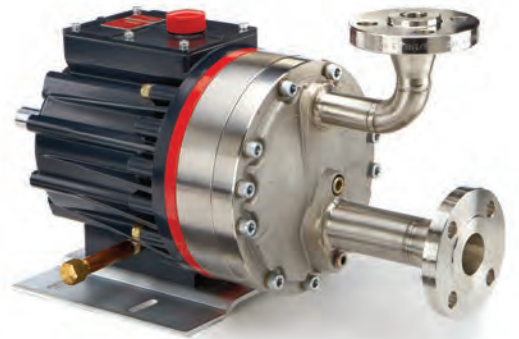

H25 with 316L Stainless Steel pump head and ANSI flanges.

H25 Series Performance

Capacities

Flow

Model	Max. Input rpm	Max. Flow @ 1000 psi (69 bar)	
		gpm	l/min
H25-X	1050	20.0	75.7
H25-E	1150	20.0	75.9
H25-S	1150	16.2	61.5
H25-I	1150	11.8	44.7

Pressure

Maximum Inlet Pressure
250 psi (17 bar)

Maximum Discharge Pressure
Metallic Pump Heads:
1000 psi (69 bar)
Non-metallic Pump Heads:
250 psi (17 bar) Polypropylene
350 psi (24 bar) PVDF

Performance and specification ratings apply to H25 configurations unless specifically noted otherwise.

Maximum Flow at Designated Pressure

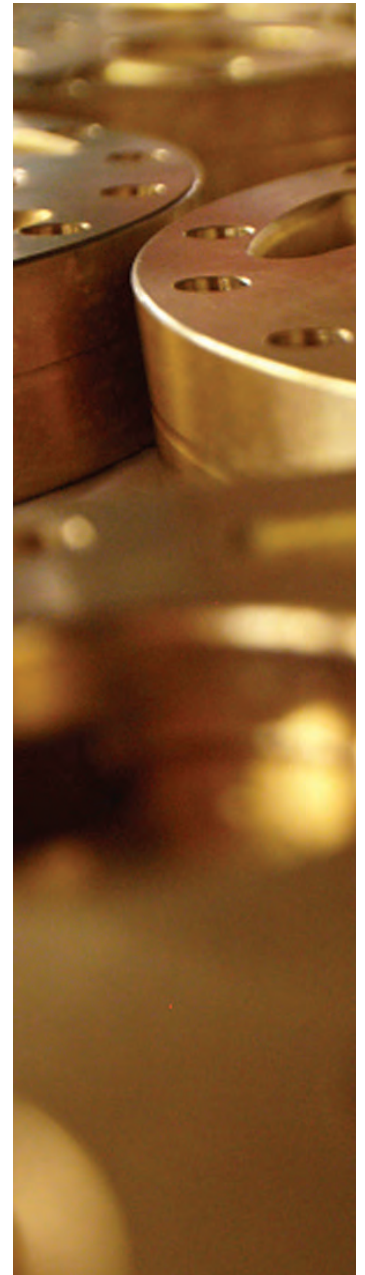
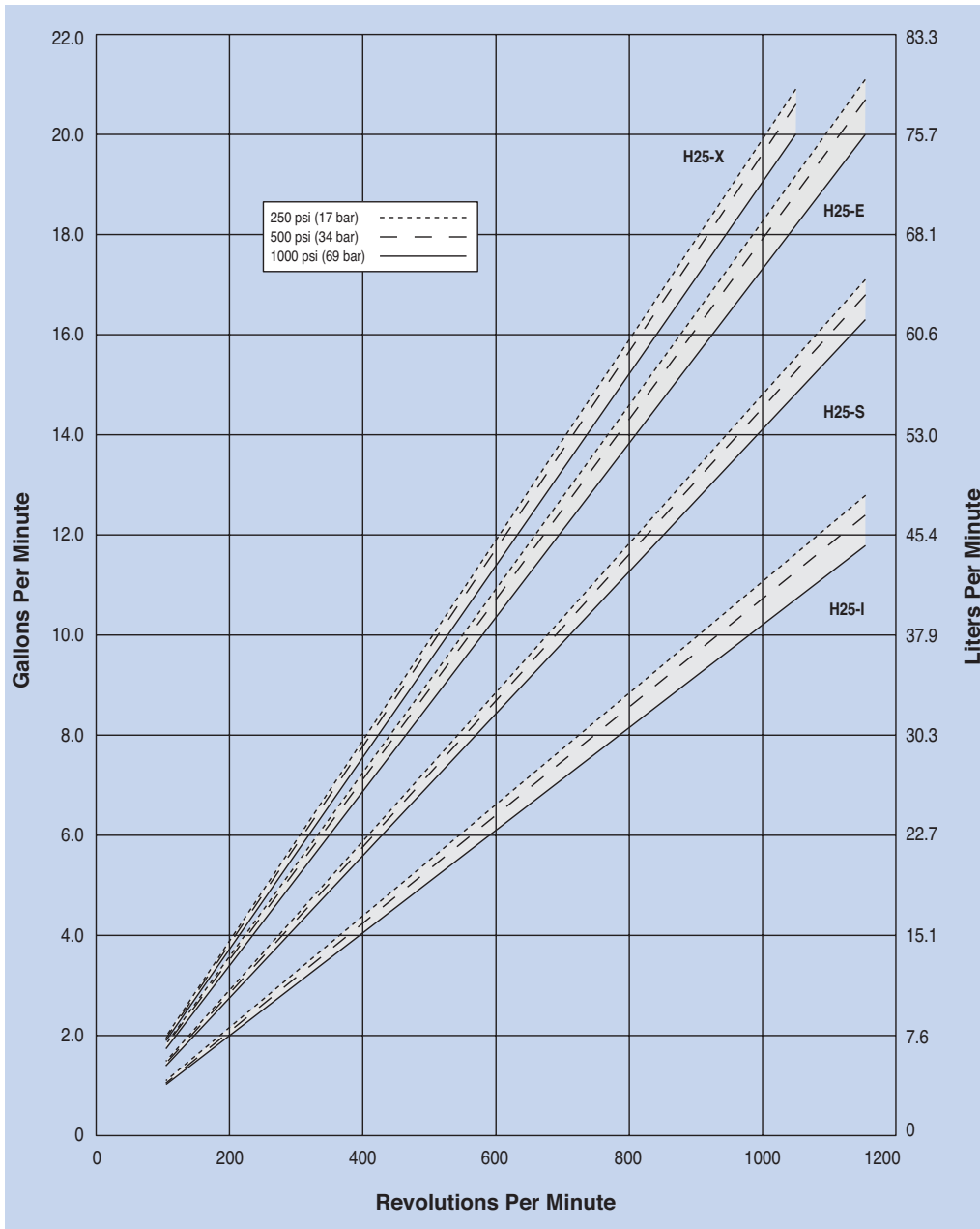

H25 Series Specifications

Flow Capacities @1000 psi (69 bar)

Model	rpm	gpm	l/min
H25-X	1050	20.0	75.7
H25-E	1150	20.0	75.9
H25-S	1150	16.2	61.5
H25-I	1150	11.8	44.7

Delivery @1000 psi (69 bar)

Model	gal/rev	liters/rev
H25-X	0.0190	0.0721
H25-E	0.0174	0.0660
H25-S	0.0141	0.0535
H25-I	0.0103	0.0389

Maximum Discharge Pressure

Metallic Heads:	1000 psi (69 bar)
Non-metallic Heads:	250 psi (17 bar) Polypropylene 350 psi (24 bar) PVDF

Maximum Inlet Pressure 250 psi (17 bar)

Maximum Operating Temperature

Metallic Heads:	250 °F (121 °C) - Consult factory for correct component selection for temperatures from 160 °F (71 °C) to 250 °F (121 °C).
Non-metallic Heads:	140 °F (60 °C)

Maximum Solids Size 800 microns

Inlet Port	1-1/2 inch NPT 150lb ANSI RF flange
-------------------	--

Discharge Port	1 inch NPT 600lb ANSI RF flange
-----------------------	------------------------------------

Shaft Diameter	1-1/8 inch (28.6 mm)
-----------------------	----------------------

Shaft Rotation	Reverse (bi-directional)
-----------------------	--------------------------

Bearings	Tapered roller bearings
-----------------	-------------------------

Oil Capacity	3.3 US quarts (3.1 liters) - See pages 100 and 101 for oil selection and specification.
---------------------	---

Weight

Metallic Heads:	125 lbs. (56.8 kg)
Non-metallic Heads:	90 lbs. (40.9 kg)

Net Positive Suction Head (NPSHr)

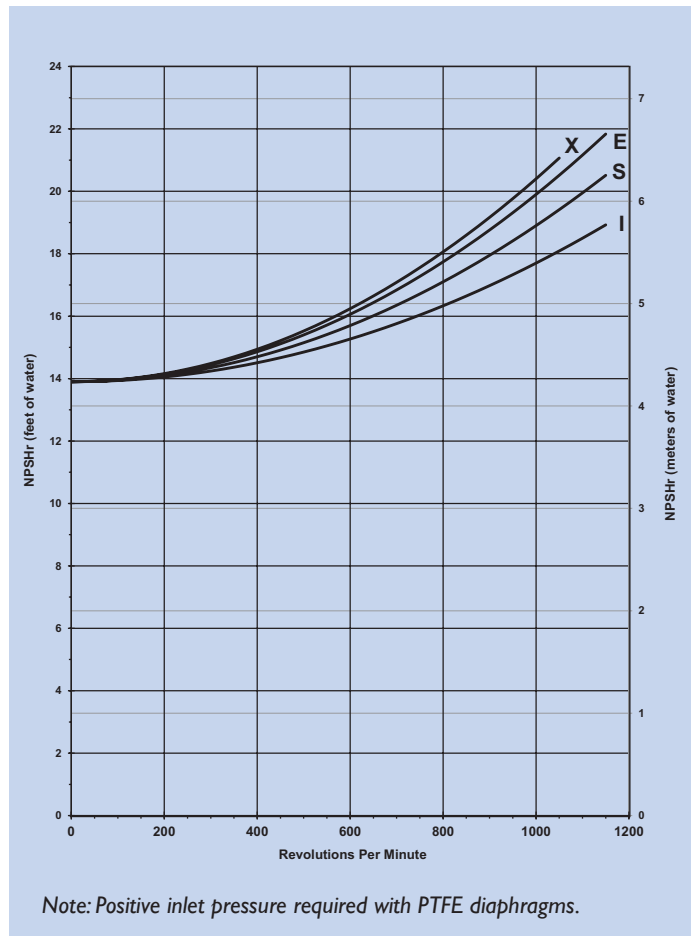

Suction Lift:

Each Hydra-Cell pump has different lift capability depending on model size, cam angle, speed, and fluid characteristics. To ensure that your specific lift characteristics are met, refer to the inlet calculations regarding friction, and acceleration head losses in your Hydra-Cell Installation & Service Manual. Compare those calculations to the NPSHr curves above.

Calculating Required Power

$$\frac{50 \times \text{rpm}}{63,000} + \frac{\text{gpm} \times \text{psi}}{1,460} = \text{electric motor hp}$$

$$\frac{50 \times \text{rpm}}{84,428} + \frac{\text{l/min} \times \text{bar}}{511} = \text{electric motor kW}$$

When using a variable frequency drive (VFD) controller calculate the hp or kW at minimum and maximum pump speed to ensure the correct hp or kW motor is selected. Note that motor manufacturers typically de-rate the service factor to 1.0 when operating with a VFD.

See page 190 for calculating pulley size

For technical assistance in pump selection, see Frequently Asked Questions on page 188, Design Considerations on page 189, and Installation Guidelines on pages 190-191.

H25 Series Representative Drawings

H25 Models with Metallic Pump Head Inches (mm)

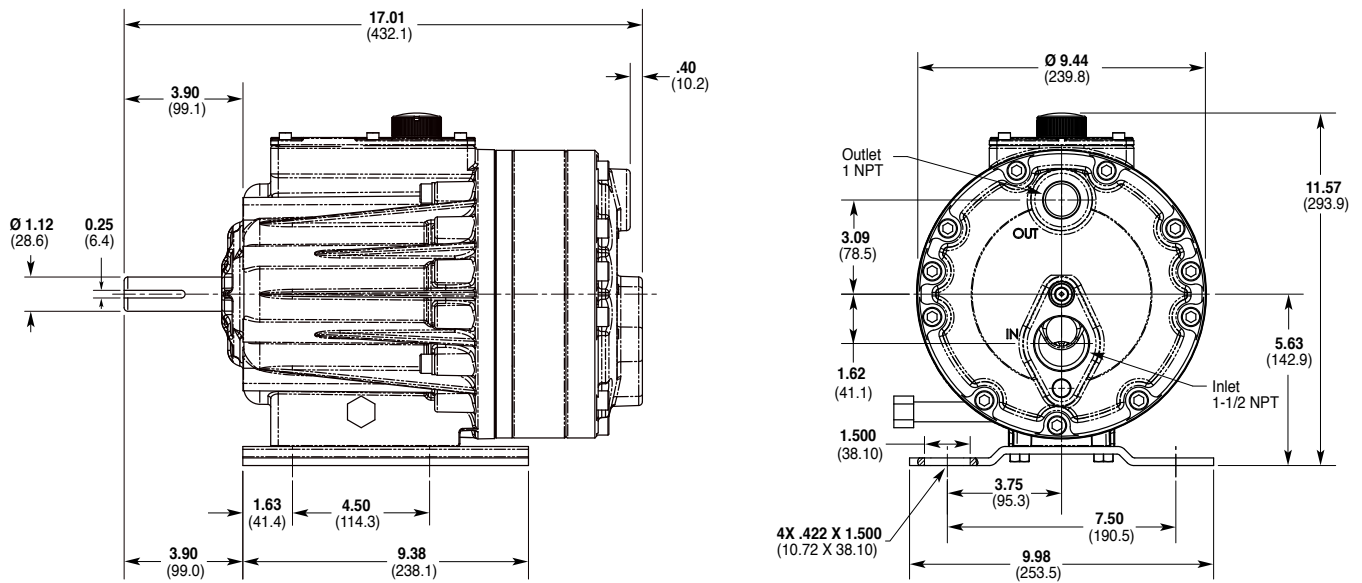

H25 Models with Non-metallic Pump Head Inches (mm)

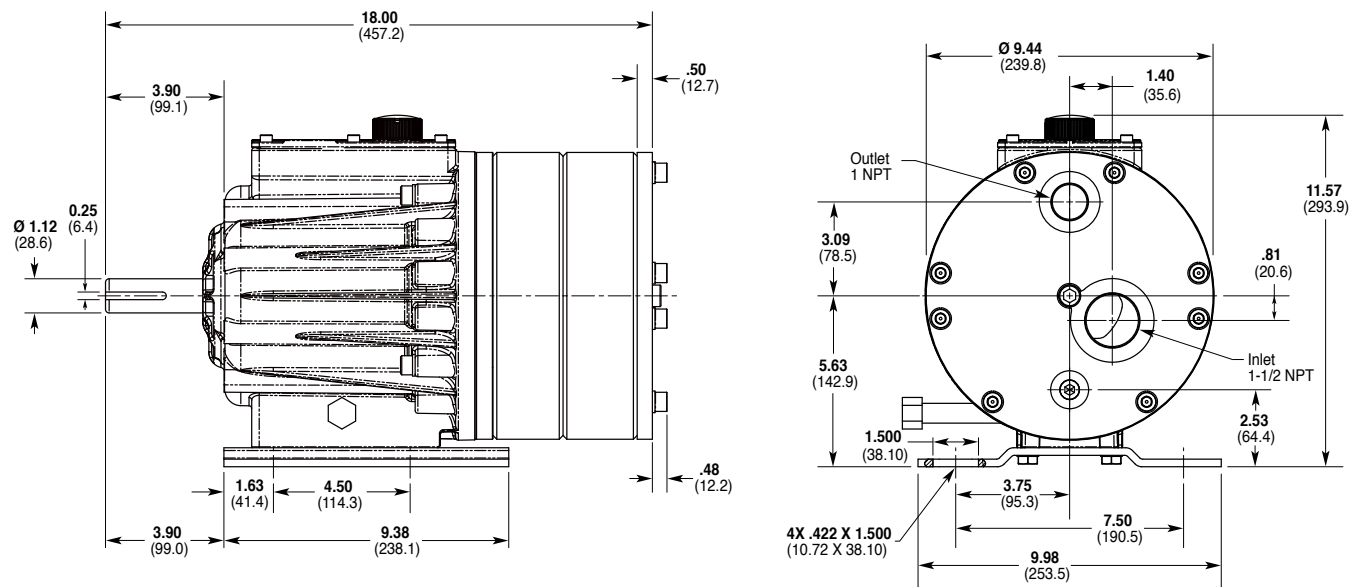

Note: Dimensions are for reference only. Contact factory for certified drawings.

H25 Series Adapters/Valves/Skids

Pump/Motor Adapter Inches (mm)

Part Number: A04-04 I - I200

For: 182TC, 184TC, 213TC, 215TC, 254TC and 256TC frame motors.

Metric adapter available - consult factory.

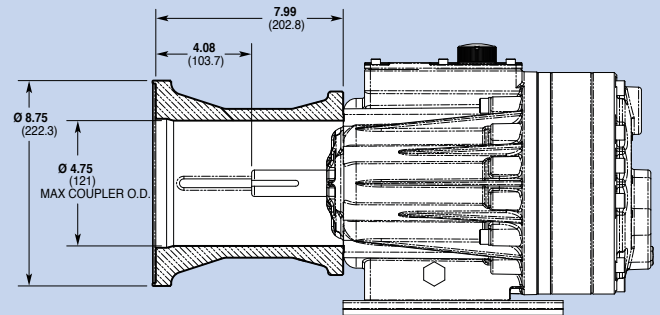

Part Number: A04-04 I - I202

For: 284TC and 286TC frame motors.

Metric adapter available - consult factory.

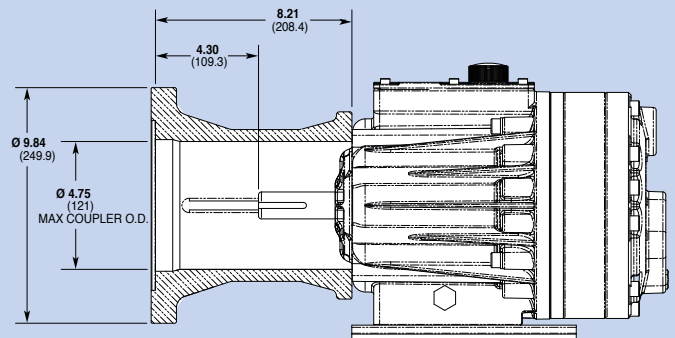

Valve Selection

A seal-less C63 Pressure Regulating Valve is recommended for Hydra-Cell H25 pumping systems, especially for high-pressure requirements or when handling dirty fluids. See page 88 for more information.



A C23 Pressure Regulating Valve provides a capable, lower-cost alternative to C63 valves for Hydra-Cell H25 pumping systems. See page 84 for more information.



Skid-mounted H25 with 15hp, 3-phase motor.

H25 Series **How to Order**

Ordering Information



A complete H25 Series Model Number contains 12 digits including 9 customer-specified design and materials options, for example: H25XKCGNNECA.

Digit	Order Code	Description
1-3	H25	Pump Configuration Shaft-driven (NPT Ports or ANSI Flanges)* *Pump/motor adapters ordered separately. See previous page.
4	X	Hydraulic End Cam Max 20.0 gpm (75.7 l/min) @ 1050 rpm
	E	Max 20.0 gpm (75.9 l/min) @ 1150 rpm
	S	Max 16.2 gpm (61.5 l/min) @ 1150 rpm
	I	Max 11.8 gpm (44.7 l/min) @ 1150 rpm
5	K	Pump Head Version Kel-Cell NPT Ports
	M	Machined housing to accept C-face adapter/gearbox
6	B	Pump Head Material Brass
	C	Cast Iron (Nickel-plated)
	G	Duplex Alloy 2205 Stainless Steel (with Hastelloy C followers & follower screws)
	M	PVDF (with Hastelloy C followers & follower screws)
	N	Polypropylene (with Hastelloy C followers & follower screws)
	P	Polypropylene (with 316L Stainless Steel followers & follower screws)
	R	316L Stainless Steel ANSI flange class 150 x 600
	S	316L Stainless Steel
	T	Hastelloy CW12MW
7	A	Diaphragm & O-ring Material Aflas diaphragm / PTFE o-ring
	E	EPDM (requires EPDM-compatible oil - Digit 12 oil code C)
	G	FKM
	J	PTFE (available with E and S cams only; 1050 rpm max.)
	P	Neoprene
	T	Buna-N
8	C	Valve Seat Material Ceramic
	D	Tungsten Carbide
	H	17-4 Stainless Steel
	N	Nitronic 50
	T	Hastelloy C

Digit	Order Code	Description
9	C	Valve Material Ceramic
	D	Tungsten Carbide
	F	17-4 Stainless Steel
	N	Nitronic 50
	T	Hastelloy C
10	E	Valve Springs Elgiloy
	H	17-7 Stainless Steel
	T	Hastelloy C
11	C	Valve Spring Retainers Celcon
	H	17-7 Stainless Steel (used with metallic heads only)
	M	PVDF
	P	Polypropylene
	T	Hastelloy C (used with metallic heads only)
	Y	Nylon (Zytel)
12	A	Hydra-Oil 10W30 standard-duty oil
	B	40-wt for continuous-duty oil (use with 316L SST or Hastelloy CW12MW pump head - standard)
	C	EPDM-compatible oil
	E	Food-contact oil
	G	5W30 cold-temp severe-duty synthetic oil
	H	15W50 high-temp severe-duty synthetic oil

**H25 Pump Housing is standard as Cast Aluminum.
Upgrade to Ductile Iron available.**

Note: For motors, bases, couplings and other pump accessories, refer to the Accessories section beginning on page 92.

D35 Series

Maximum Flow Rate: 36.5 gpm (138 l/min)

Maximum Pressure: 1200 psi (83 bar) for Metallic Pump Heads



D35 with 316L Stainless Steel pump head.



D35 with Brass pump head.



D35 with 316L Stainless Steel pump head and ANSI flanges.

D35 Series Performance

Capacities

Flow

Model	Max. Input rpm	Max. Flow	
		@ 1200 psi (83 bar) gpm	l/min
D35-X	1050	36.5	138
D35-E	1150	34.0	129
@ 1500 psi (103 bar)*			
D35-X	700	23.1	87.5

Pressure

Maximum Inlet Pressure

250 psi (17 bar) with 1500 psi (103 bar) maximum discharge pressure
 500 psi (34 bar) with 1200 psi (83 bar) maximum discharge pressure

Maximum Discharge Pressure

1200 psi (83 bar) @ 1150 rpm max.
 1500 psi (103 bar)* @ 700 rpm max.

Performance and specification ratings apply to D35 configurations unless specifically noted otherwise.

Maximum Flow at Designated Pressure

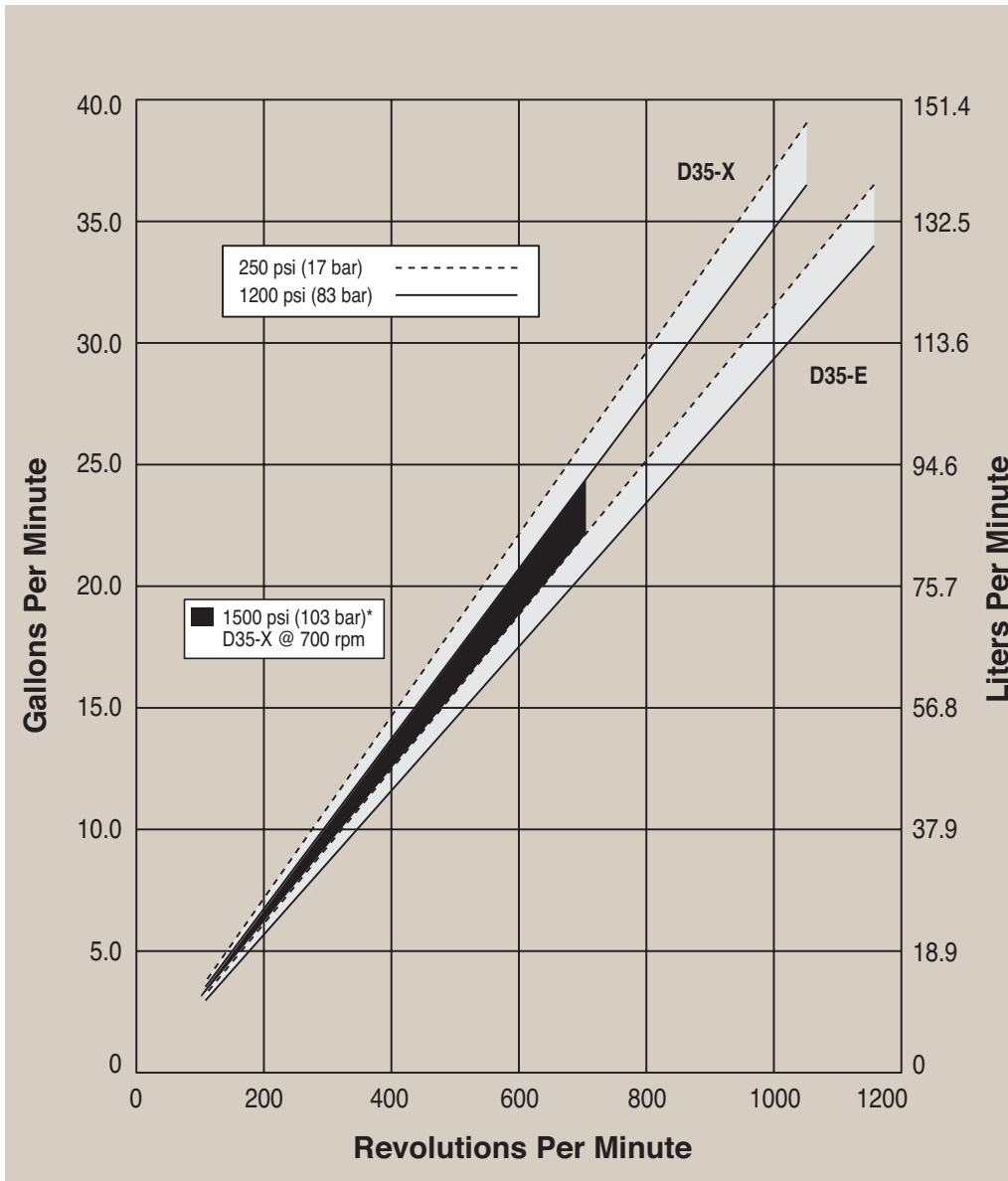

* Consult factory if operating above 1200 psi (83 bar).

D35 Series Specifications

Flow Capacities @1200 psi (83 bar)

Model	rpm	gpm	l/min
D35-X	1050	36.5	138
D35-E	1150	34.0	129

Delivery @1200 psi (83 bar)

Model	gal/rev	liters/rev
D35-X	0.0347	0.1314
D35-E	0.0296	0.1120

Delivery @1500 psi (103 bar)

Model	gal/rev	liters/rev
D35-X	0.0330	0.1250

Maximum Discharge Pressure

Metalllic Heads: 1200 psi (83 bar) @ 1150 rpm max.
1500 psi (103 bar) @ 700 rpm max. – Consult factory if operating above 1200 psi (83 bar).

Maximum Inlet Pressure 250 psi (17 bar) with 1500 psi (103 bar) maximum discharge pressure
500 psi (34 bar) with 1200 psi (83 bar) maximum discharge pressure

Maximum Operating Temperature

Metalllic Heads: 250 °F (121 °C) - Consult factory for correct component selection for temperatures from 160 °F (71 °C) to 250 °F (121 °C).

Maximum Solids Size 800 microns

Inlet Port 2-1/2 inch NPT
150lb or 600lb ANSI RF flange
3 inch SAE flange

Discharge Port 1-1/4 inch NPT
600lb or 1500lb ANSI RF flange
1-1/4 inch SAE flange

Shaft Diameter 2 inch (50.8 mm)

Shaft Rotation Reverse (bi-directional)

Bearings Tapered roller bearings

Oil Capacity 7.75 US quarts (7.3 liters) - See pages 100 and 101 for oil selection and specification.

Weight

Metalllic Heads: 257 lbs. (116.6 kg)

Net Positive Suction Head (NPSHr)

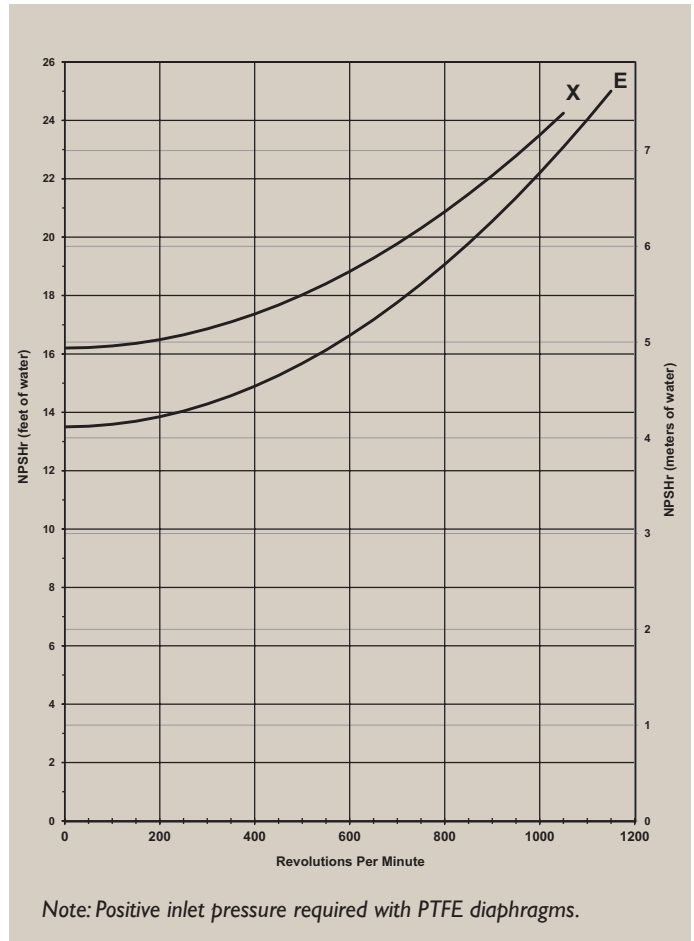

Suction Lift:

Each Hydra-Cell pump has different lift capability depending on model size, cam angle, speed, and fluid characteristics. To ensure that your specific lift characteristics are met, refer to the inlet calculations regarding friction, and acceleration head losses in your Hydra-Cell Installation & Service Manual. Compare those calculations to the NPSHr curves above.

Calculating Required Power

$$\frac{100 \times \text{rpm}}{63,000} + \frac{\text{gpm} \times \text{psi}}{1,460} = \text{electric motor hp}$$

$$\frac{100 \times \text{rpm}}{84,428} + \frac{\text{l/min} \times \text{bar}}{511} = \text{electric motor kW}$$

When using a variable frequency drive (VFD) controller calculate the hp or kW at minimum and maximum pump speed to ensure the correct hp or kW motor is selected. Note that motor manufacturers typically de-rate the service factor to 1.0 when operating with a VFD.

See page 190 for calculating pulley size.

For technical assistance in pump selection, see Frequently Asked Questions on page 188, Design Considerations on page 189, and Installation Guidelines on pages 190-191.

D35 Series Representative Drawings

D35 Models with NPT Inlet/Outlet Ports Inches (mm)

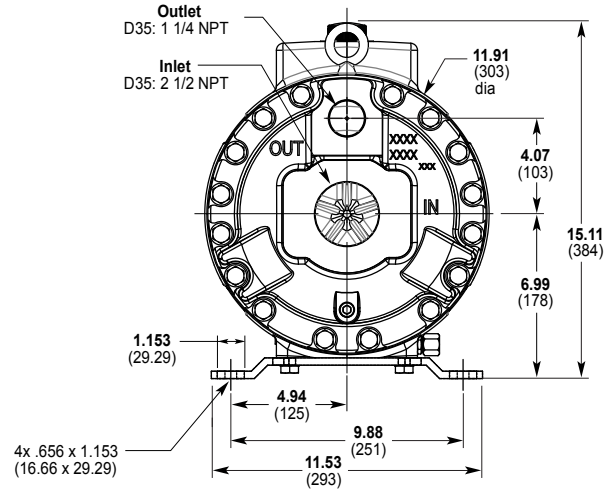
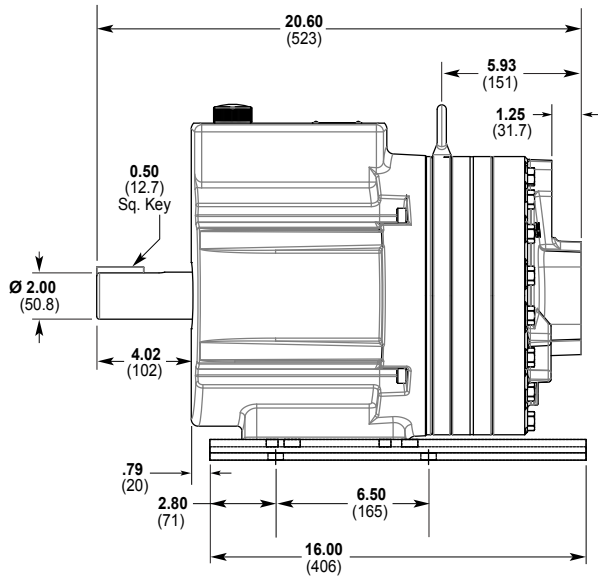

D35 Models with SAE Flange Inlet/Outlet Ports Inches (mm)

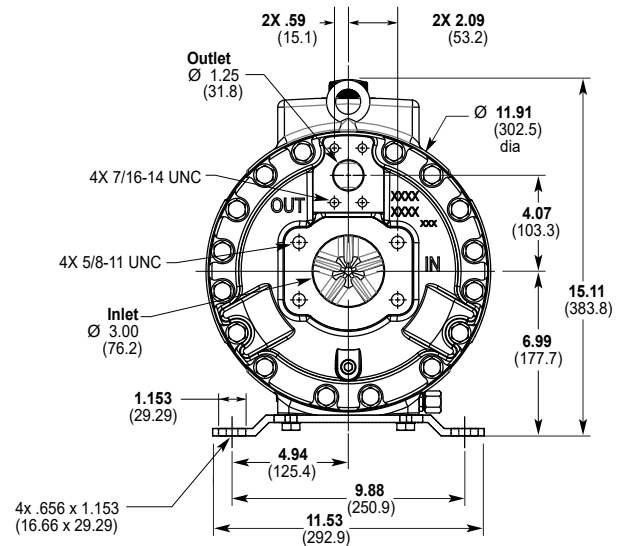
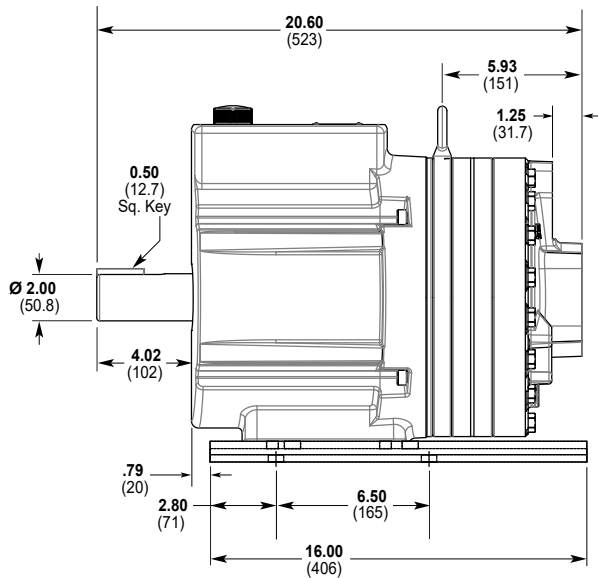

Note: Dimensions are for reference only. Contact factory for certified drawings.

D35 Series Representative Drawings/Valves/Skids

D35 Models with ANSI Flange Inlet/Outlet Ports Inches (mm)

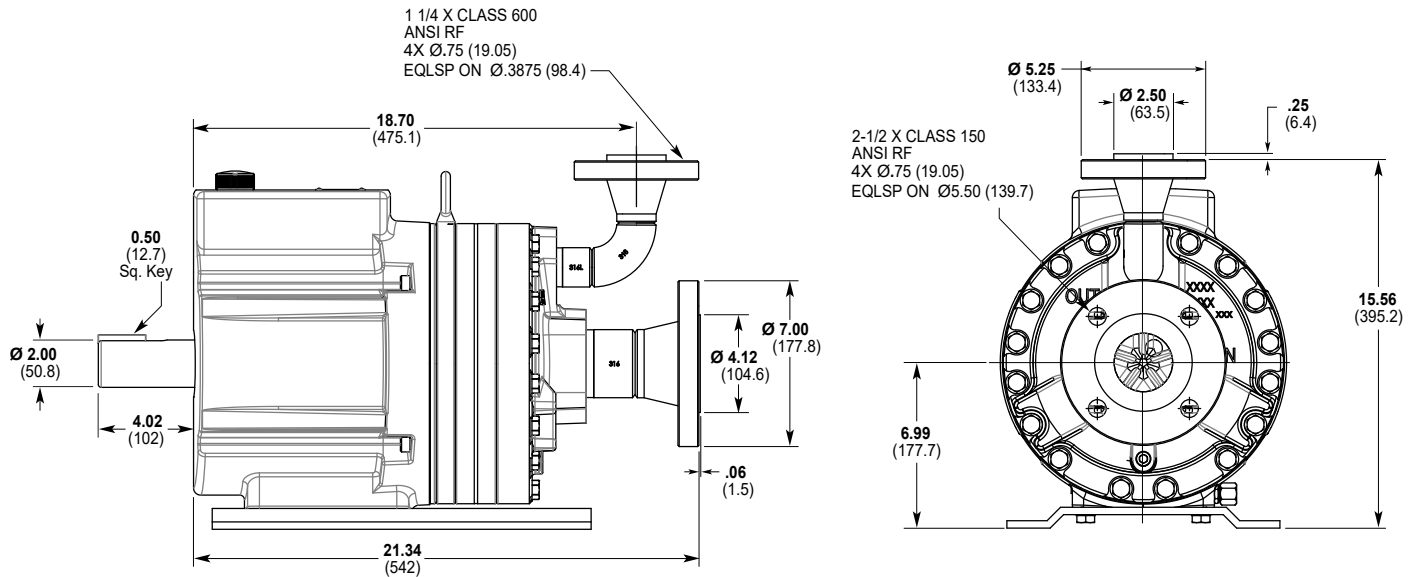

Note: Dimensions are for reference only. Contact factory for certified drawings.

Valve Selection

A seal-less C64 Pressure Regulating Valve is recommended for Hydra-Cell D35 pumping systems, especially for high-pressure requirements or when handling dirty fluids. See page 88 for more information.



A C24 Pressure Regulating Valve provides a capable, lower-cost alternative to C64 valves for Hydra-Cell D35 pumping systems. See page 84 for more information.



Skid-mounted D35 with 20hp, 3-phase motor.



D35 Series How to Order

Ordering Information



A complete D35 Series Model Number contains 12 digits including 9 customer-specified design and materials options, for example: D35XKBTHFECA.

Digit	Order Code	Description
1-3	D35	Pump Configuration Shaft-driven (NPT Ports or SAE or ANSI Flanges)
4	X	Hydraulic End Cam Max 36.5 gpm (138 l/min) @ 1050 rpm
	E	Max 34.0 gpm (129 l/min) @ 1150 rpm
5	K	Pump Head Version Kel-Cell NPT Ports or ANSI Flanges
	E	Kel-Cell SAE Flanges
6	B	Pump Head Material Brass
	C	Ductile Iron (Nickel-plated)
	G	Duplex Alloy 2205 Stainless Steel (with Hastelloy C followers & follower screws)
	Q	316L Stainless Steel ANSI flange class 600 x 1500
	R	316L Stainless Steel ANSI flange class 150 x 600
	S	316L Stainless Steel - threaded or SAE ports
	T	Hastelloy CW12MW
7	A	Diaphragm & O-ring Material Atlas diaphragm / PTFE o-ring
	E	EPDM (requires EPDM-compatible oil - Digit 12 oil code D)
	G	FKM
	J	PTFE (available with E cam only; 1050 rpm max.)
	P	Neoprene
	T	Buna-N
8	C	Valve Seat Material Ceramic
	D	Tungsten Carbide (900 rpm max.)
	H	17-4 Stainless Steel
	N	Nitronic 50
	T	Hastelloy C
9	C	Valve Material Ceramic
	D	Tungsten Carbide (900 rpm max.)
	F	17-4 Stainless Steel
	N	Nitronic 50
	T	Hastelloy C

Digit	Order Code	Description
10	E	Valve Springs Elgiloy
	H	17-7 Stainless Steel
	T	Hastelloy C
11	C	Valve Spring Retainers Celcon
	H	17-7 Stainless Steel
	M	PVDF
	P	Polypropylene
	T	Hastelloy C
	Y	Nylon (Zytel)
12	A	Hydra-Oil 10W30 standard-duty oil
	B	40-wt for continuous-duty oil (use with 316L SST or Hastelloy CW12MW pump head - standard)
	D	EPDM-compatible oil
	E	Food-contact oil
	G	5W30 cold-temp severe-duty synthetic oil
	H	15W50 high-temp severe-duty synthetic oil

D35 Pump Housing is standard as Cast Aluminum. Upgrade to Ductile Iron available.

Note: For motors, bases, couplings and other pump accessories, refer to the Accessories section beginning on page 92.

D66 Series

Maximum Flow Rate: 62.5 gpm (236.6 l/min) 2142 BPD
Maximum Pressure: 1000 psi (69 bar) for Metallic Pump Heads
250 psi (17 bar) for Non-Metallic Pump Heads



D66 with Brass pump head and SAE flanged ports.



D66 with Brass pump head and NPT ports.



D66 with Stainless Steel pump head and BSPT ports.



D66 with Polypropylene pump head and SAE flanged ports.

D66 Series Performance

Capacities

Flow

Model	Max. Input rpm	Max. Flow @ 1000 psi (69 bar)		
		gpm	l/min	BPD
D66-X	1000	62.5	236.6	2142

Pressure

Maximum Inlet Pressure

Metallic Pump Heads: 250 psi (17 bar)
 Non-metallic Pump Heads: 50 psi (3.4 bar)

Maximum Discharge Pressure

Metallic Pump Heads:
 1000 psi (69 bar)
 Non-metallic Pump Heads:
 250 psi (17 bar)

Performance and specification ratings apply to D66 configurations unless specifically noted otherwise.

Maximum Flow at Designated Pressure

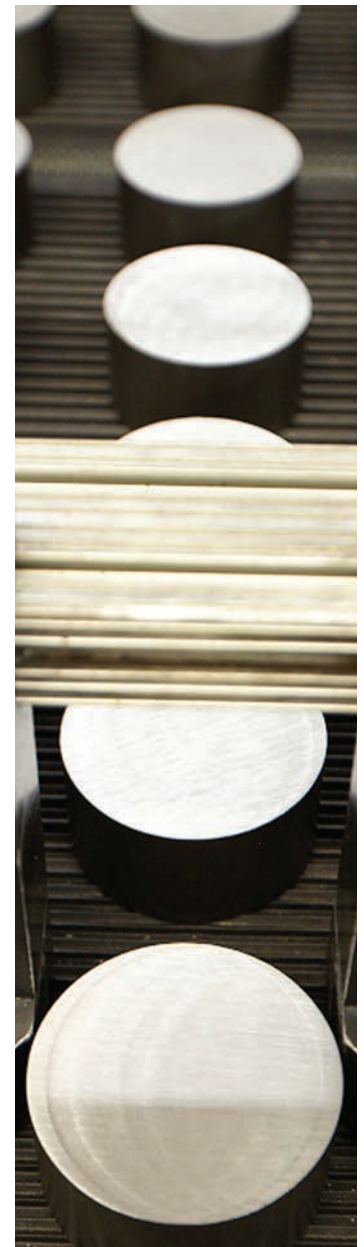
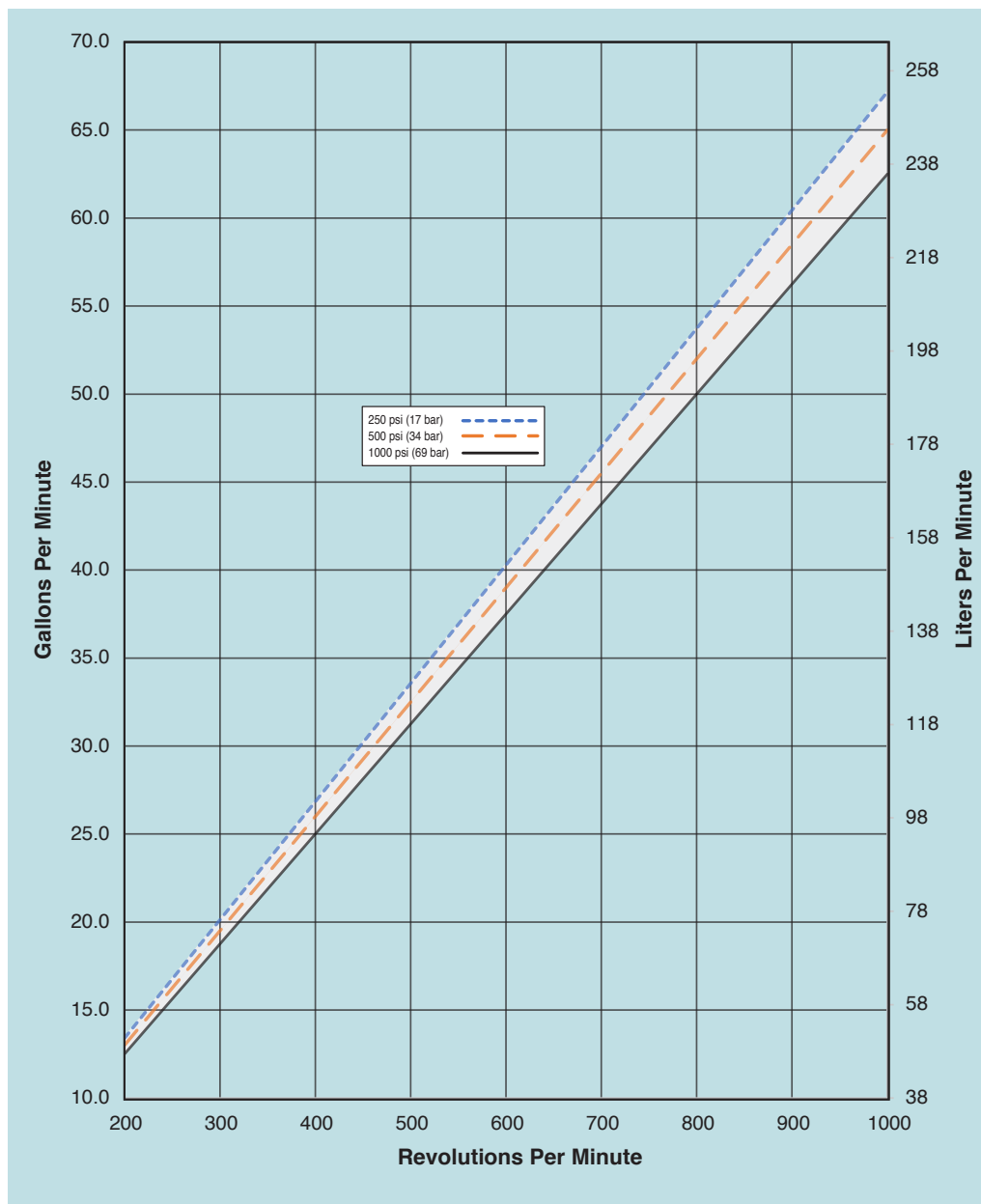

D66 Series Specifications

Flow Capacities @ 250 psi (17 bar)

Model	rpm	gpm	l/min	BPD
D66-X (Non-metallic)	1000	66.9	253.2	2293

Flow Capacities @ 500 psi (34 bar)

Model	rpm	gpm	l/min	BPD
D66-X (Metallic)	1000	65.0	246.1	2228

Flow Capacities @ 1000 psi (69 bar)

Model	rpm	gpm	l/min	BPD
D66-X (Metallic)	1000	62.5	236.6	2142

Delivery @ 250 psi (17 bar)

Model	gal/rev	liters/rev
D66-X (Non-metallic)	0.0669	0.253

Delivery @ 500 psi (34 bar)

Model	gal/rev	liters/rev
D66-X (Metallic)	0.0650	0.246

Delivery @ 1000 psi (69 bar)

Model	gal/rev	liters/rev
D66-X (Metallic)	0.0625	0.237

Maximum Discharge Pressure

Metallc Heads:	1000 psi (69 bar)
Non-metallic Heads:	250 psi (17 bar)

Maximum Inlet Pressure	Metallc Heads:	250 psi (17 bar)
	Non-metallic Heads:	50 psi (3.4 bar)

Maximum Operating Temperature

Metallc Heads:	200 °F (93.3 °C) - Consult factory for correct component selection for temperatures from 160 °F (71 °C) to 200 °F (93.3 °C).
Non-metallic Heads:	120 °F (49 °C) - Consult factory for temperatures above 120 °F (49 °C).

Maximum Solids Size	800 microns
----------------------------	-------------

Inlet Port	3 inch NPT (Metallc) 2-1/2 inch SAE J518 Flange (Non-metallic) 3 inch SAE J518 Flange (Metallc)
-------------------	---

Discharge Port	1-1/2 inch NPT 1-1/2 inch SAE
-----------------------	----------------------------------

Shaft Diameter	2 inch (50.8 mm)
-----------------------	------------------

Shaft Rotation	Reverse (bi-directional)
-----------------------	--------------------------

Bearings	Tapered roller bearings
-----------------	-------------------------

Oil Capacity	11 US quarts (10.4 liters) - See page 100 and 101 for oil selection and specification.
---------------------	--

Weight

Metallc Heads:	400 lbs. (181 kg)
Non-metallic Heads:	275 lbs. (125 kg)

Net Positive Suction Head (NPSHr)

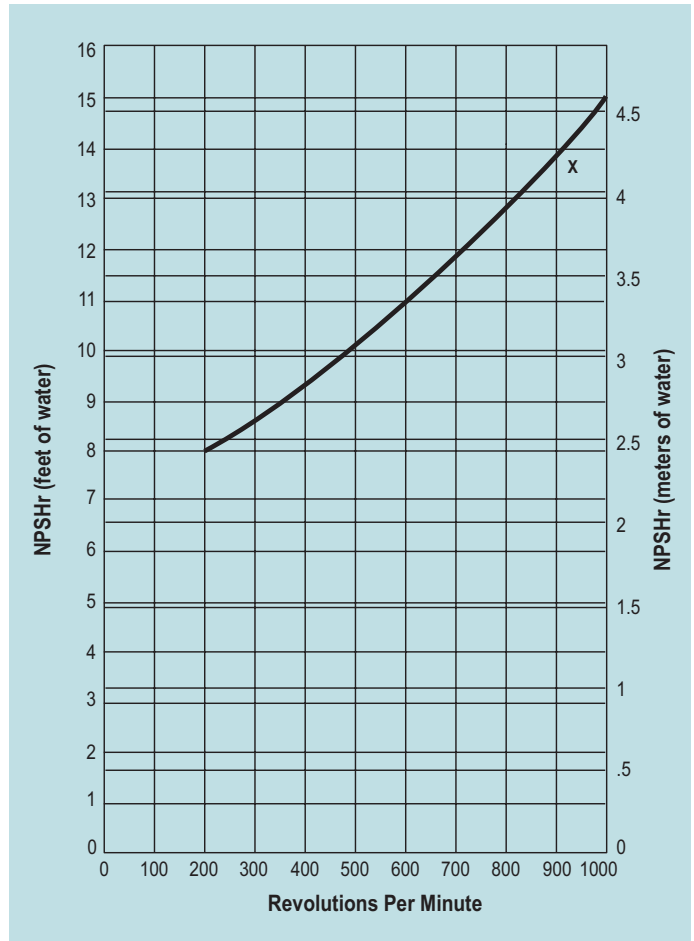

Suction Lift:

Each Hydra-Cell pump has different lift capability depending on model size, cam angle, speed, and fluid characteristics. To ensure that your specific lift characteristics are met, refer to the inlet calculations regarding friction, and acceleration head losses in your Hydra-Cell Installation & Service Manual. Compare those calculations to the NPSHr curves above.

Calculating Required Power

$$\frac{100 \times \text{rpm}}{63,000} + \frac{\text{gpm} \times \text{psi}}{1,460} = \text{electric motor hp}$$

$$\frac{100 \times \text{rpm}}{84,428} + \frac{\text{l/min} \times \text{bar}}{511} = \text{electric motor kW}$$

When using a variable frequency drive (VFD) controller calculate the hp or kW at minimum and maximum pump speed to ensure the correct hp or kW motor is selected. Note that motor manufacturers typically de-rate the service factor to 1.0 when operating with a VFD.

See page 190 for calculating pulley size

For technical assistance in pump selection, see Frequently Asked Questions on page 188, Design Considerations on page 189, and Installation Guidelines on pages 190-191.

D66 Series Representative Drawings

D66 Models with SAE Flange Inlet/Outlet Ports Inches (mm)

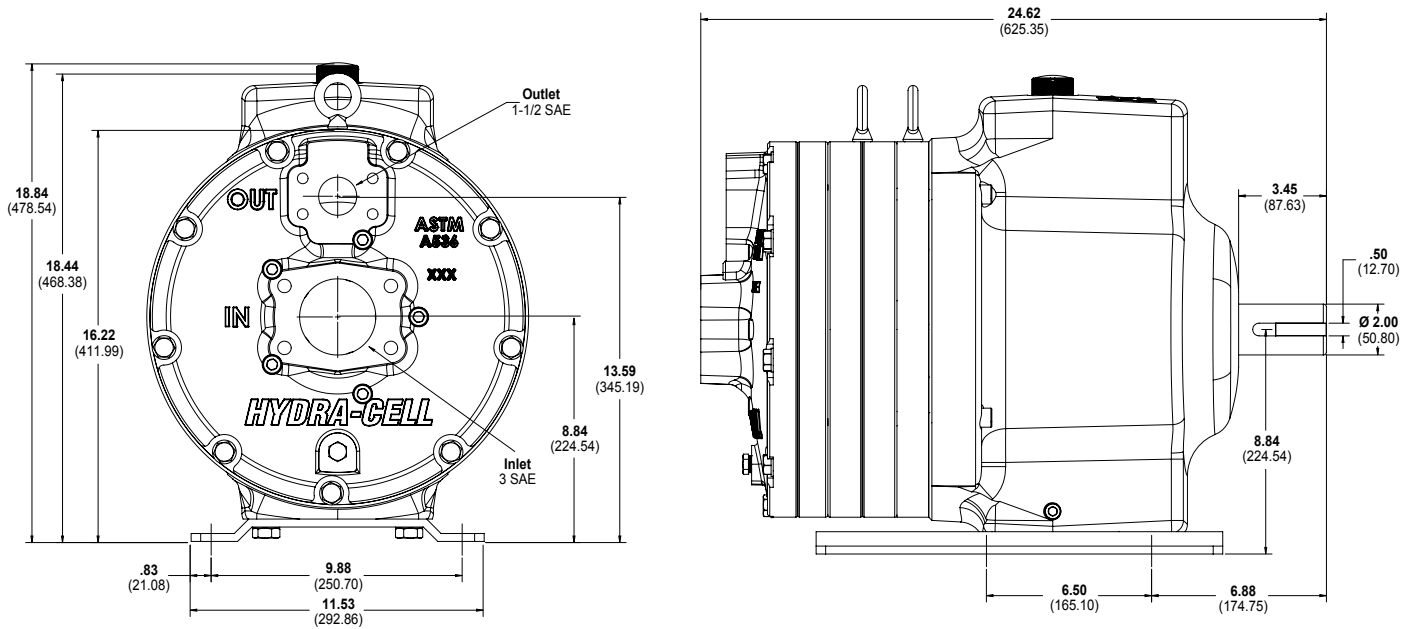

Metallic pump head models shown.

D66 Models with SAE Flange Inlet/Outlet Ports Inches (mm)

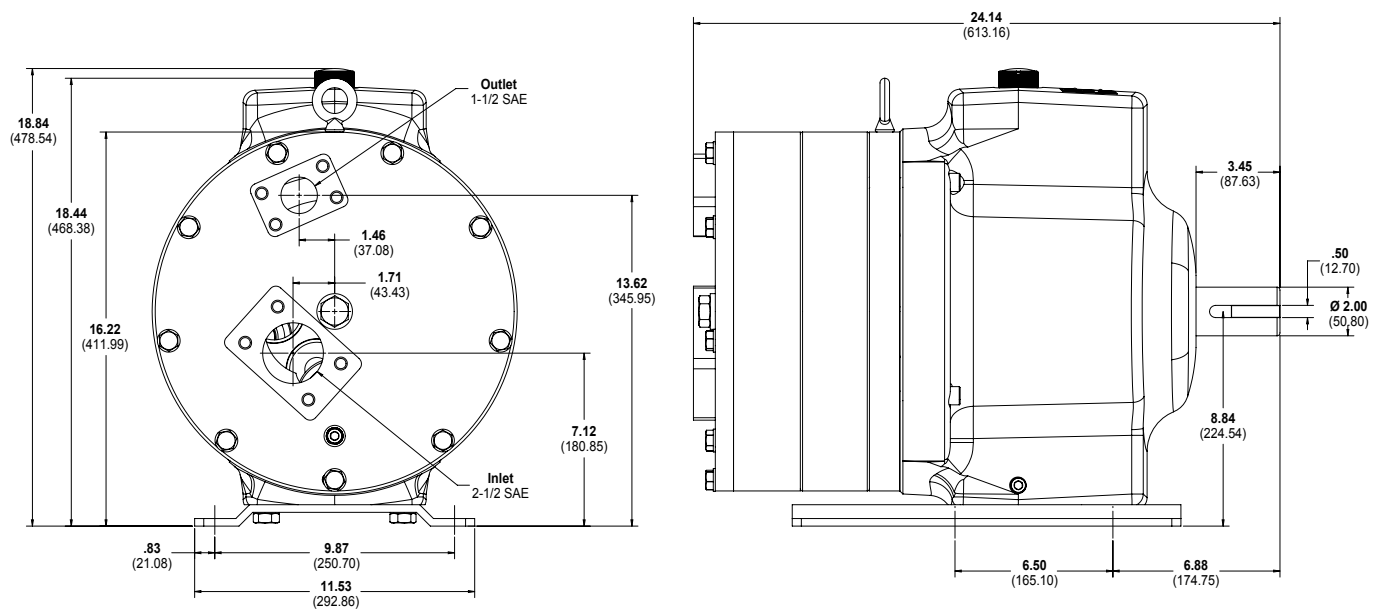

Non-metallic pump head models shown.

Note: Dimensions are for reference only. Contact factory for certified drawings.

D66 Series Representative Drawings

D66 Models with NPT Inlet/Outlet Ports Inches (mm)

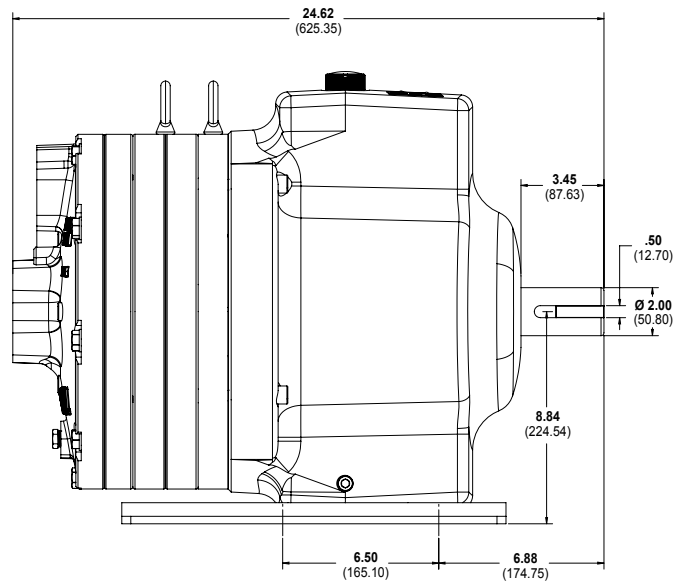
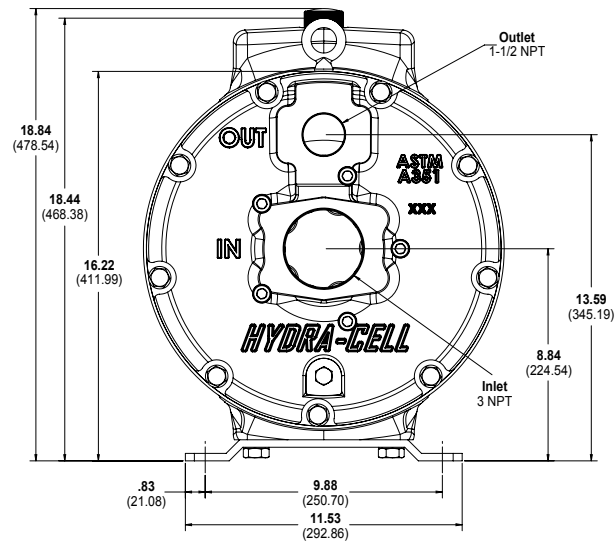

Metallic pump head models shown.

Note: Dimensions are for reference only. Contact factory for certified drawings.

D66 Series **How to Order**

Ordering Information

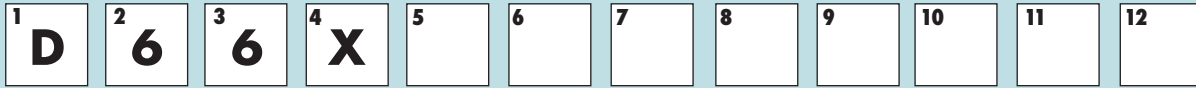

A complete D66 Series Model Number contains 12 digits including 8 customer-specified design and materials options, for example: D66XKSGHFMMH.

Digit	Order Code	Description
1-3	D66	Pump Configuration Shaft-driven
4	X	Hydraulic End Cam Max. 62.5 gpm (236.6 l/min) 2142 BPD @ 1000 rpm
5	K	Pump Head Version Advanced Diaphragm Position Control (ADPC) NPT Ports (metallic heads only)
	E	Advanced Diaphragm Position Control (ADPC) SAE Flanged Ports
6	B	Pump Head Material Brass
	C	Ductile Iron (Nickel-plated)
	G	Duplex Alloy 2205 Stainless Steel (with Hastelloy C followers & follower screws)
	N	Polypropylene (with Hastelloy C followers and follower screws) - SAE only
	P	Polypropylene (with 316 SST followers & follower screws) - SAE only
	S	316L Stainless Steel
7	E	Diaphragm & O-ring Material EPDM (used with metallic heads only)
	R	EPDM (used with non-metallic heads only)
	G	FKM (used with metallic heads only)
	H	FKM (used with non-metallic heads only)
	T	Buna-N (used with metallic heads only)
	U	Buna-N (used with non-metallic heads only)
8	H	Valve Seat Material 17-4 Stainless Steel
	N	Nitronic 50
	T	Hastelloy C
9	F	Valve Material 17-4 Stainless Steel
	N	Nitronic 50
	T	Hastelloy C
10	E	Valve Springs Elgiloy
	H	17-7 Stainless Steel
	T	Hastelloy C

Digit	Order Code	Description
11	C	Valve Spring Retainers Celcon
	M	PVDF
12	C	Hydra-Oil EPDM-compatible oil
	H	15W50 high-temp severe-duty synthetic oil

Note: For motors, bases, couplings and other pump accessories, refer to the Accessories section beginning on page 92.

C Series Valves Selection Guide

Pressure Regulating Valves



C20 Series
Page 84



C46 Series
Page 86



C60 Series
(Seal-less Valves)
Page 88

Air Bleed Priming Valves



C80 Series
Page 90

C Series Pressure Regulating Valves

Versatile Application for Positive Displacement Pumps

Designed for use with any positive displacement pump, Hydra-Cell C Series pressure regulating valves bypass system fluid to prevent excess system pressure. They can also be used as pressure relief valves.

When a system discharge is completely closed (e.g. closed spray gun, closed valve, plugged nozzle) the Hydra-Cell valve bypasses the total system fluid flow. The valves also balance system pressure for multiple-gun operations.

Design Advantages



Tapered design of the C20 Series valves plunger.

The valve design is based on using a simple tapered plunger with a valve seat. When excess pressure overcomes the adjustable spring pressure on the plunger, the plunger lifts off the seat, allowing fluid to bypass and reduce system pressure.

When the valve is mounted in the discharge line, its modified flow-through design reduces wear on the plunger and seat. Baffles on either side of the plunger and seat extend valve life by directing flow around these critical components.

Seal-less Diaphragm



C60 Series valves feature a seal-less diaphragm with a tapered plunger, making the valves ideal for high-pressure requirements and handling dirty fluids.

Performance Advantages

- Accurate and repeatable.
- Adjustable.
- Immediate response.
- Smooth, chatter-free bypass.
- No external springs or moving parts.
- Flow-through design with minimal pressure surge.
- Heavy-duty construction.

Easy to Service

Hydra-Cell C Series valves can be serviced in place without removing any fittings or plumbing. Simply remove the top of the body and replace any worn internal components.



The model C62 seal-less valve is the most frequently specified pressure regulating valve in a Hydra-Cell pumping system.

C20 Series Valves

Dimensions

C22 with 3/4" NPT Ports Inches (mm)



C22 valve with Brass body.

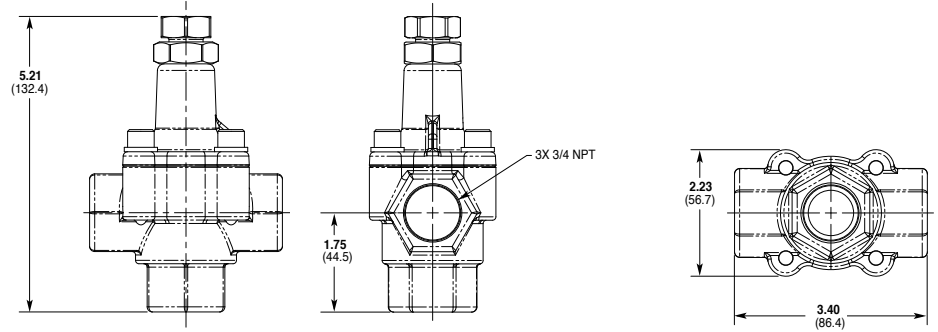

C23 with 1" NPT Ports Inches (mm)



C23 valve with Stainless Steel body.

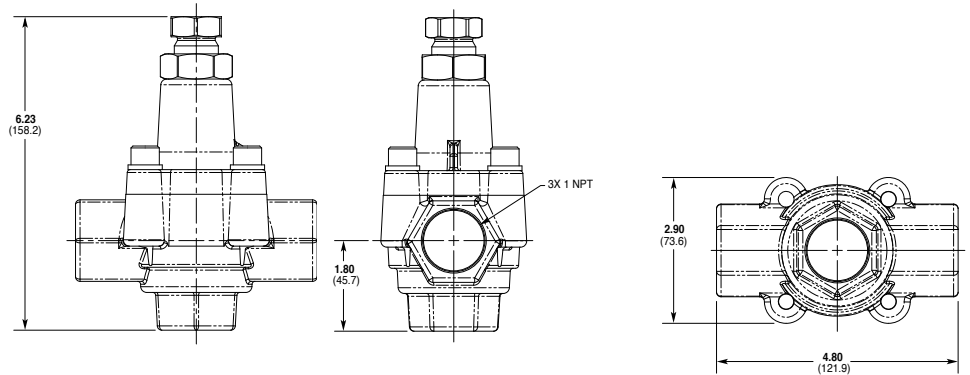

C24 with 1-1/4" NPT Ports Inches (mm)



C24 valve with Brass body.

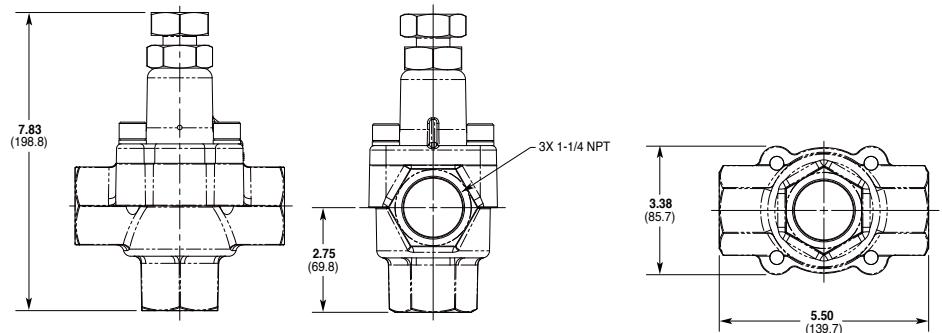

C20 Series Valves How to Order

Ordering Information

1	2	3	4	5	6	7	8	9	10	11
C	2		A							

A complete C22, C23 or C24 Model Number contains 11 digits, including 8 customer-specified design and material options, for example: C22AABNSSEF.

Digit	Order Code	Description
1-3		Valve Configuration & Capacities
	C22	3-10 gpm (11.3-37.8 l/min)
	C23	3-20 gpm (11.3-75.7 l/min)
	C24	5-40 gpm (18.9-151.4 l/min)
4	A	Inlet/Outlet Ports NPT Ports
5		Pressure Range (Spring Selection)
	A	75-500 psi (5-34 bar)
	B	500-1000 psi (34-69 bar)
	C	1000-1500 psi (69-103 bar)
6		Body/Top Material
	B	Brass/Plated Steel
	H	Hastelloy CW12MW/Plated Steel
	S	316L Stainless Steel/Plated Steel
7		Seals/Back-up Seals
	A	Urethane/UHMW Polyethylene
	B	FKM/UHMW Polyethylene
	E	EPDM/PTFE
	N	Buna-N/Buna-N
	V	FKM/PTFE
8		Valve Seats
	H	Hastelloy C
	R	316L Stainless Steel
	S	17-4 Stainless Steel
	T	Tungsten Carbide
9		Plungers
	H	Hastelloy C
	R	316L Stainless Steel
	S	17-4 Stainless Steel
	T	Tungsten Carbide
10		Seat Size
	E	For C22 Models
	J	For C23 Models
	N	For C24 Models
11		Port Size
	F	For C22 Models (3/4")
	G	For C23 Models (1")
	H	For C24 Models (1-1/4")

For reference on identifying metallic components of C20 Series plungers and plunger valve seats, see page 192.

Ratings and Specifications

Flow Capacity Model	Maximum		Minimum	
	gpm	l/min	gpm	l/min
C22	10.0	37.8	3.0	11.3
C23	20.0	75.7	3.0	11.3
C24	40.0	151.4	5.0	18.9

Pressure Range (All Models)	Model Configuration		
	AA	AB	AC
psi	75-500	500-1000	1000-1500
bar	5-34	34-69	69-103

Max. Temperature	200° F (93° C)
-------------------------	----------------

Inlet & Outlet Ports	
C22	3/4" NPT
C23	1" NPT
C24	1-1/4" NPT

Weight	
C22	3 lbs. (1.3 kg)
C23	6 lbs. (2.7 kg)
C24	10 lbs. (4.5 kg)

C22 valves are used with Hydra-Cell models D10 and D12.

C23 valves are used with Hydra-Cell model H25.

C24 valves are used with Hydra-Cell models D35 and D66.

C20 Series valves can be used as a lower-cost alternative to C60 Series seal-less valves when higher discharge pressures are not required.

C46 Series Valves

Dimensions

C46 for In-Line Mount with 3/8" NPT Ports Inches (mm)



C46 In-line with Stainless Steel body.

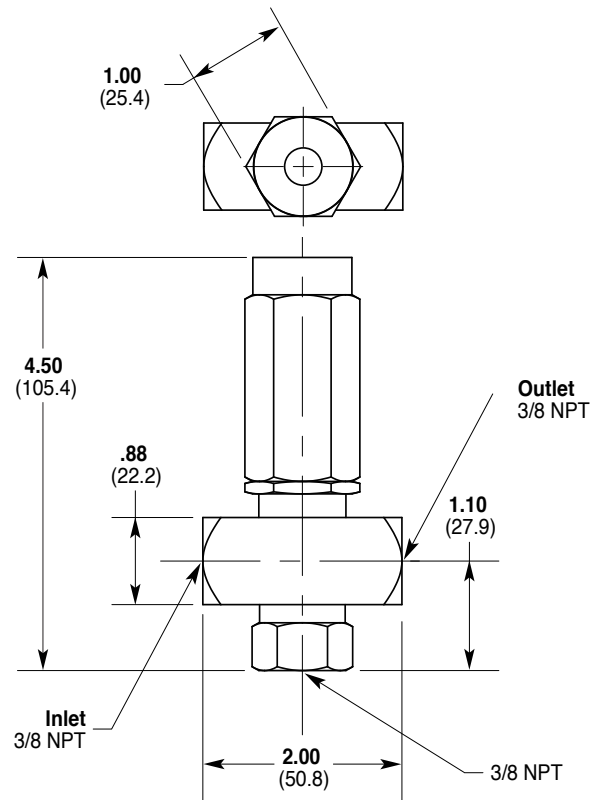

C46 Off-line with Brass body.

C46 for Off-Line Mount with 3/8" NPT Ports Inches (mm)



C46 Off-line with Stainless Steel body.

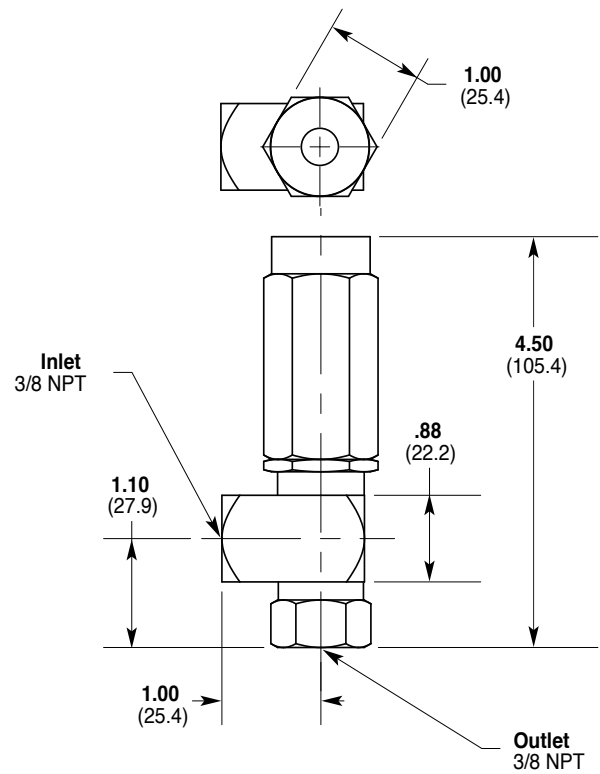

C46 Series Valves How to Order

Ordering Information

1	2	3	4	5	6	7	8	9	10	11
C	4	6					S	S	E	E

A complete C46 Model Number contains 11 digits, including 4 customer-specified design and material options, for example: C46AABESSEE

Digit	Order Code	Description
1-3		Valve Configuration & Capacities
	C46	0.2-10 gpm (1-37.8 l/min) NPT Ports
4		Mounting Design
	A	In-line
	B	Off-line
5		Pressure Range (Spring Selection)
	A	Low Spring: 50-500 psi (3-34 bar)
	B	Medium Spring: 100-900 psi (7-62 bar)
	C	Standard Spring: 200-1500 psi (13-103 bar)
6		Body Material
	B	Brass
	S	316L Stainless Steel
7		O-rings
	E	EPDM
	N	Buna-N
	V	FKM
8		Piston
	S	316L Stainless Steel
9		Seat
	S	316L Stainless Steel
10		Seat Size
	E	For C46 Models
11		Port Size
	E	For C46 Models (3/8" NPT)

Ratings and Specifications

Flow Capacity Model	Maximum		Minimum	
	gpm	l/min	gpm	l/min
C46 In-line	7.0	26.5	0.2	1.0
C46 Off-line	10.0	37.8	0.2	1.0
Pressure Range				
Low Spring	50-500 psi (3-34 bar)			
Medium Spring	100-900 psi (7-62 bar)			
Standard Spring	200-1500 psi (13-103 bar)			
Max. Temperature	200° F (93° C)			
Inlet & Outlet Ports	3/8" NPT			
Weight	12 oz. (0.33 kg)			

C46 Series valves are used with Hydra-Cell models F20, F21, F22, M03/D03, and M03/D03 Mono-Block.

C60 Series Valves

Dimensions



C62 valve with Stainless Steel body.

C62 with 3/4" NPT Ports Inches (mm)

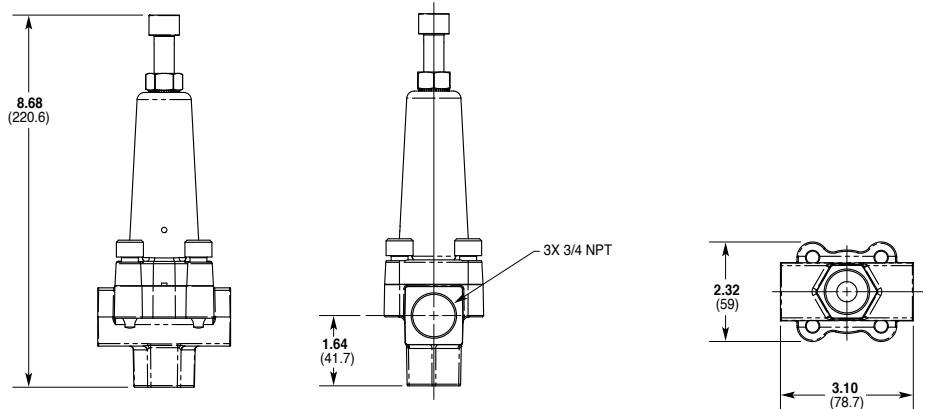

C63 valve with Brass body.

C63 with 1" NPT Ports Inches (mm)

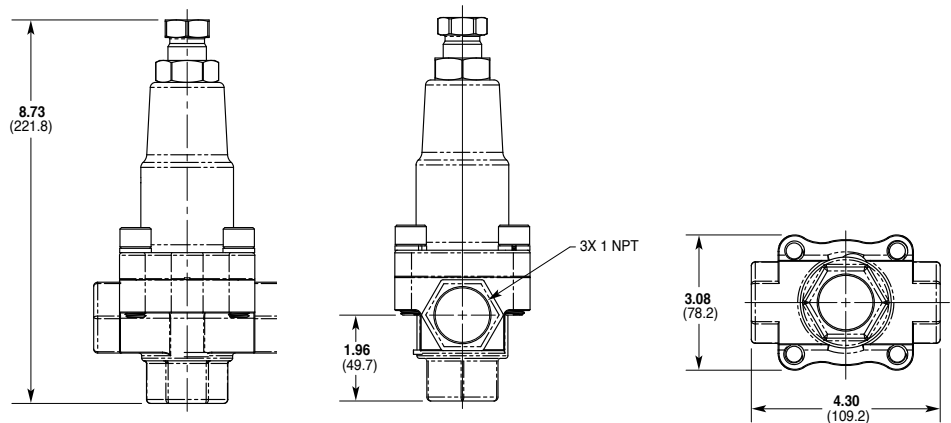

C64 valve with Stainless Steel body.

C64 with 1-1/4" NPT Ports Inches (mm)

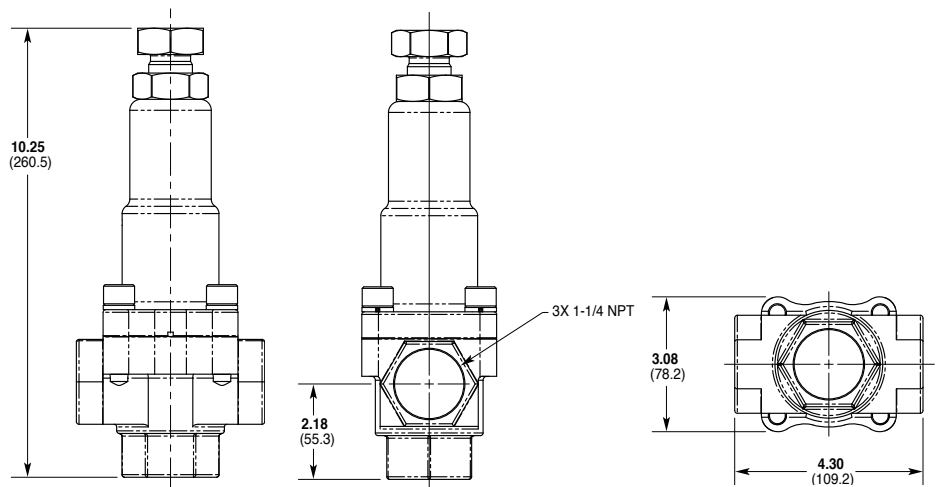

C60 Series Valves How to Order

Ordering Information

1	2	3	4	5	6	7	8	9	10	11
C	6		A							

A complete C62, C63 or C64 Model Number contains 11 digits, including 8 customer-specified design and material options, for example: C62ABBSSEF.

Digit	Order Code	Description
1-3	C62	Valve Configuration & Capacities 1-14 gpm (3-53.0 l/min)
	C63	1-25 gpm (3-94.6 l/min)
	C64	1-40 gpm (3-151.4 l/min)
4	A	Inlet/Outlet Ports NPT Ports
5	A	Pressure Range (Spring Selection) C62: 75-500 psi (5-34 bar) C63: 75-1000 psi (5-69 bar) C64: 75-1000 psi (5-69 bar)
	B	C62: 500-2500 psi (34-172 bar) C63: 1000-2500 psi (69-172 bar) C64: 1000-2500 psi (69-172 bar)
6	B	Body/Top Material Brass/Plated Steel
	H	Hastelloy C/Plated Steel (available for C62 only)
	S	316L Stainless Steel/Plated Steel
7	J	O-rings/Diaphragm PTFE/PTFE
	V	FKM/PTFE
8	H	Valve Seats Hastelloy C (available for C62 only)
	R	316L Stainless Steel
	S	17-4 Stainless Steel
	T	Tungsten Carbide (available for C62 only)
9	H	Plungers Hastelloy C (available for C62 only)
	R	316L Stainless Steel
	S	17-4 Stainless Steel
	T	Tungsten Carbide (available for C62 only)
10	E	Seat Size For C62 Models
	J	For C63 Models
	N	For C64 Models
11	F	Port Size For C62 Models (3/4")
	G	For C63 Models (1")
	H	For C64 Models (1-1/4")

Notes:

Hastelloy C Body available only for C62 models.

Hastelloy C and Tungsten Carbide Valve Seat/Plunger options available only for C62 models.

C62 models fitted with Tungsten Carbide Valve Seats/Plungers rated to 1800 psi (124 bar) maximum.

Ratings and Specifications

Flow Capacity Model	Maximum		Minimum	
	gpm	l/min	gpm	l/min
C62	14.0	53.0	1.0	3.8
C63	25.0	94.6	1.0	3.8
C64	40.0	151.4	1.0	3.8

Pressure Range	Model Configuration	
	AA	AB
C62	psi	75-500
	bar	5-34
C63	psi	75-1000
	bar	5-69
C64	psi	75-1000
	bar	5-69

Max. Temperature 200° F (93° C)

Inlet & Outlet Ports	
C62	3/4" NPT
C63	1" NPT
C64	1-1/4" NPT

Weight	
C62	4.0 lbs. (1.8 kg)
C63	6.2 lbs. (2.8 kg)
C64	7.2 lbs. (3.3 kg)

C62 valves are recommended for Hydra-Cell models D04, D10, D12, and D15/D17.

C63 valves are recommended for Hydra-Cell model H25.

C64 valves are recommended for Hydra-Cell model D35.

The model C62 seal-less valve is the most frequently specified pressure regulating valve in a Hydra-Cell pumping system.

C80 Series Valves

Air Bleed Priming Valves

C80 Series valves provide an effective air/vapor release mechanism for diaphragm pump systems.

The valve automatically creates an open port to atmosphere for the pumping system. This allows the pump to clear air or vapors from the pump head and discharge plumbing rather than compressing the gas and reducing flow. The valve then closes to develop full system pressure immediately.

- Design is simple and reliable.
- Easy to install and maintain.
- Mounts vertically or horizontally.
- Heavy-duty construction.
- Available in a choice of materials and flow ranges to suit your application.



C80 with Brass body.



C80 with Stainless Steel body.



C80 with PVDF body.



Detail of valve components. The C80 Series Air Bleed valves are used with Hydra-Cell models F20, M03, D04, D10 and D12.

Dimensions Inches (mm)

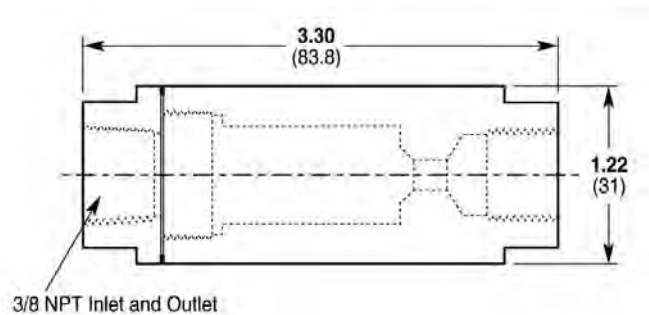

C80 Series Valves How to Order

Ordering Information

1	2	3	4	5	6	7	8	9
C	8	0	A					

A complete C80 Model Number contains 9 digits, including 5 customer-specified design and material options, for example: C80AAHBEB.

Digit	Order Code	Description
1-3		Valve Configuration & Capacities
	C80	1.4-10 gpm (5.3-37.8 l/min) NPT Ports
4		Mounting Design
	A	3/8" NPT Thread
5-6		Flow Range (Spring Selection)
	AH	1.4-3 gpm (5.3-11.4 l/min) / Hastelloy spring
	BH	2.4-5 gpm (9.1-18.3 l/min) / Hastelloy spring
	CH	4.6-7 gpm (17.4-26.5 l/min) / Hastelloy spring
	DH	6.5-10 gpm (24.6-37.8 l/min) / Hastelloy spring
	DE	6.5-10 gpm (24.6-37.8 l/min) / Elgiloy spring
7		Body Material
	B	Brass
	H	Hastelloy C
	M	PVDF (250 psi; 17 bar maximum pressure)
	S	316L Stainless Steel
8		O-rings
	E	EPDM
	N	Buna-N
	P	Neoprene
	V	FKM
9		Poppet
	B	Brass
	H	Hastelloy C
	S	17-4 Stainless Steel

Ratings and Specifications

Flow Capacity Configuration	Maximum		Minimum	
	gpm	l/min	gpm	l/min
AH	3.0	11.4	1.4	5.3
BH	5.0	18.3	2.4	9.1
CH	7.0	26.5	4.6	17.4
DH	10.0	37.8	6.5	24.6
DE	10.0	37.8	6.5	24.6

Pressure Range

Metallic Units	75-2500 psi	(5-172 bar)
Non-metallic Units	75-250 psi	(5-17 bar)

Max. Discharge

Pressure Required	75 psi (5 bar)
-------------------	----------------

Max. Temperature	200° F (93° C)
------------------	----------------

Inlet & Outlet Ports	3/8" NPT
----------------------	----------

Weight

Brass	1.0 lbs.	(0.45 kg)
Stainless Steel	1.0 lbs.	(0.45 kg)
PVDF	0.3 lbs.	(0.14 kg)

Hydra-Cell® Pumps Accessories and Options



As part of our “Mass Customization” approach, Hydra-Cell pumps are available with a variety of in-stock accessories and options to provide a pumping system ideally suited to your installation and application.

Note: Accessories in this section apply to Hydra-Cell F Series, M Series, D Series, and H Series pumps as well as Hydra-Cell P Series and MT8 metering pumps. Additional information about metering pump accessories can be found on page 185.

Accessory/Option	Page
Couplings	93
Motors	94
Motor Adapters	98
Motor Baseplates & Guards	98
Hydra-Oil Lubricants.....	100
Oil Cooler & Filter Systems	102
Oil Level Monitoring Mounting Kits	105
Oil Level Reservoir Sight Bottles	106
Vacuum Priming Kit	106
Priming Plugs	106
Tool Kits	107
Replacement Parts Kits	108
Replacement Hydraulic Ends.....	108
Controllers	109
Calibration Cylinders	112
Back Pressure & Pressure Relief Valves.....	113
Pulsation Dampeners	116
Demonstration Units	120
Testing.....	121

Couplings



Couplings with sleeves are available in a wide range of motor sizes for Hydra-Cell pumping systems.

Coupling Selection Guide

When selecting a coupling, note that horsepower (hp) values are for reference only under normal pump operation within rated specification. Please consult factory for critical performance or harsh-duty applications.

Coupling Series	Bore Ø (in.)	Maximum hp @ Designated Speed (rpm)		Part Number
		1750	1150	
M24	5/8 x 5/8	4.0	2.6	A04-024-1201
	5/8 x 7/8			A04-024-1202
	5/8 x 24 mm			A04-024-1203
	7/8 x 24 mm			A04-024-1204
	7/8 x 7/8			A04-024-1205
M28	5/8 x 5/8	9.1	5.8	A04-028-1201
	5/8 x 7/8			A04-028-1202
	5/8 x 1-1/8			A04-028-1203
	7/8 x 7/8			A04-028-1204
	7/8 x 1-1/8			A04-028-1205
	7/8 x 24 mm			A04-028-1206
	7/8 x 28 mm			A04-028-1208
M38	7/8 x 1-1/8	16.1	10.4	A04-038-1202
	7/8 x 1-3/8			A04-038-1203
	1-1/8 x 1-1/8			A04-038-1204
	1-1/8 x 1-3/8			A04-038-1205
M42	1-1/8 x 1-1/8	20.4	13.3	A04-042-1201
	1-1/8 x 1-3/8			A04-042-1202
	1-1/8 x 1-5/8			A04-042-1203
M48	1-1/8 x 1-1/8	28.3	20.2	A04-048-1201
	1-1/8 x 1-3/8			A04-048-1202
	1-1/8 x 1-5/8			A04-048-1203
	1-1/8 x 1-7/8			A04-048-1204
M65	1-1/8 x 2-1/8	84.5	50	A04-065-1201
	1-5/8 x 2			A04-065-1202
	1-7/8 x 2			A04-065-1203
	2 x 2-1/8			A04-065-1204
	1-3/8 x 2			A04-065-1205

Motor Shaft Size Reference

Pump Model	Pump Shaft Ø	
	Inches	mm
F20	5/8 hollow shaft	-
F21	5/8	15.9
F22	5/8	15.9
M03*	5/8 hollow shaft	-
D03*	7/8	22.2
D04	7/8	22.2
D10	7/8	22.2
D12	7/8	22.2
D15	1-1/8	28.6
D17	1-1/8	28.6
H25	1-1/8	28.6
D35	2	50.8
D66	2	50.8

* Includes Mono-Block

Nominal Motor hp at Designated Speed (rpm)	Motor Frame Size	Motor Shaft Ø (in.)
1/4 to 1	56C	5/8
1-1/2	143T	7/8
2	145T	7/8
3	182T	1-1/8
5	184T	1-1/8
7-1/2	213T	1-3/8
10	215T	1-3/8
15	254T	1-5/8
20	256T	1-5/8
25	284T	1-7/8
30	286T	1-7/8
-	324T	2-1/8
-	326T	2-1/8

Motors

Motors provide the rotary action that engages the shaft of a Hydra-Cell pump or operates the gear reducer on a Hydra-Cell Metering Solutions pump. A motor for a specific pump is selected based on the horsepower (hp), revolutions per minute (rpm), and turndown ratio required for the application (performance criteria) in gallons per minute (gpm) or liters per minute (l/min).

Selection Process

1. On the pump model (e.g. M03, D10, H25) “Performance” page for your pump, locate the Maximum Flow at Designated Pressure (gpm or l/min) for your application.
2. On the pump model “Specifications” page for your pump, locate the formula for Calculating Required Power (hp or kW) and plug in the rpm, gpm (or l/min) and psi (or bar).
3. Using the motor selection charts in this section (based on required hp and corresponding motor frame for your model) match the required rpm (1200 or 1800) with the correct turndown ratio for your pump.



Model M03 with C-face motor.



Model H25 with C-face motor and flanged adapter.

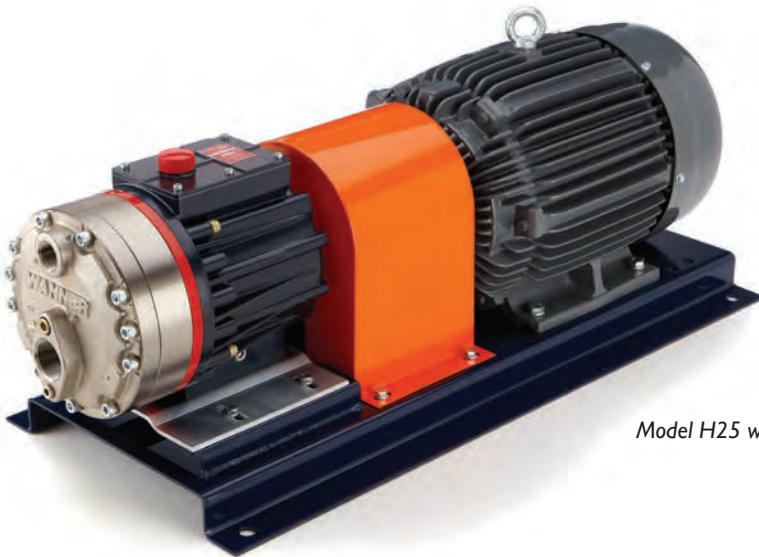

Model H25 with motor and coupling guard.

Note: Contact factory for hazardous-location motors.

Motors

Motors, NEMA 56C Frame, Footed, 1 Phase

HP	RPM	Frame	Part Number	Enclosure	Voltage/Hz	Shipping Weight (lbs.)
1/2	1800	56C	M50TE18F1P56CLO	TEFC	115-230/60	23
3/4	1800	56C	M75TE18F1P56CLO	TEFC	115-230/60	30
1	1800	56HC	M100TE18F1P56CLO	TEFC	115-230/60	31
1-1/2	1800	56HC	M150TE18F1P56CLO	TEFC	115-230/60	40

Motors, NEMA 56C Frame, Footed, 3 Phase

HP	RPM	Frame	Part Number	Turndown Ratio (CT)	Enclosure	Voltage/Hz	Shipping Weight (lbs.)
1/2	1800	56C	M50TE18F3P56CA3	10:1	TEFC	230-460/60	35
	1800	56C	M50TN18F3P56CA5	1000:1*	TENV	230-460/60	24
	1200	56C	M50TE12F3P56CA3	10:1	TEFC	230-460/60	42
3/4	1800	56C	M75TE18F3P56CA3	10:1	TEFC	230-460/60	35
	1200	56C	M75TE12F3P56CA3	10:1	TEFC	230-460/60	42
1	1800	56C	M100TE18-3P56C	0	TEFC	230-460/60	28
	1800	56C	M100TE18F3P56CA3	10:1	TEFC	230-460/60	29
	1800	56C	M100TN18F3P56CA5	1000:1*	TENV	230-460/60	41
	1200	56C	M100TE12-3P56C	10:1	TEFC	230-460/60	42
1-1/2	1800	56C	M150TE18F3P56CA3	10:1	TEFC	230-460/60	48
	1800	56C	M150WD18F3P56CA5	1000:1*	TENV	230-460/60	34
2	1800	56C	M200TE18F3P56CA3	10:1	TEFC	230-460/60	49

* If operating under 6HZ (greater than 10:1 turndown), or not operating with a VFD, consult factory.

Motors, Hazardous-duty Location, Explosion Proof, NEMA 56C Frame, Footed, 3 Phase

- Class I and II, Groups C, D, F & G.
- CSA certified.
- UL listed.
- Continuous duty at 104°F (40°C) ambient.
- Consult the National Electric Code and your local regulations for proper selection of motors in hazardous locations.

HP	RPM	Frame	Part Number	Turndown Ratio (CT)	Enclosure	Voltage/Hz	Shipping Weight (lbs.)
1/4	1800	56C	M25EX18F3P56CA5	1000:1*	TENV	230-460/60	26
1/2	1800	56C	M50EX18F3P56CA5	1000:1*	TENV	230-460/60	31
3/4	1800	56C	M75EX18F3P56CA5	1000:1*	TENV	230-460/60	38
1	1800	56C	M100EX18F3P56CA5	1000:1*	TENV	230-460/60	43

* If operating under 6HZ (greater than 10:1 turndown), or not operating with a VFD, consult factory.

Motors

Motors, C-Face, Footed, 3 Phase

- Totally-enclosed, fan-cooled (TEFC), continuous-duty, 230/460V, 60Hz, 3P.
- 1.15 service factor (1.0 when operated with a VFD).
- Cast Iron construction.
- 10:1 rated motors are NEMA premium efficiency.
- Class “F” insulation with Class “B” rise.
- 50Hz data on nameplate - 190/380V at 1.0 service factor.
- UL recognized with CE mark on label.

HP	RPM	Frame	Part Number	Turndown Ratio (CT)	Shipping Weight (lbs.)
1	1800	143TC	M100TE18F3P143TCA3	10:1	50
	1200	145TC	M100TE12F3P145TCA3	10:1	92
1-1/2	1800	145TC	M150TE18F3P145TCA3	10:1	80
	1200	182TC	M150TE12F3P182TCA3	10:1	122
2	1800	145TC	M200TE18F3P145TCA3	10:1	85
	1200	184TC	M200TE12F3P184TCA3	10:1	134
3	1800	182TC	M300TE18F3P182TCA3	10:1	137
	1200	213TC	M300TE12F3P213TCA3	10:1	166
5	1800	184TC	M500TE18F3P184TCA3	10:1	135
	1200	215TC	M500TE12F3P215TCA3	10:1	212
7-1/2	1800	213TC	M750TE18F3P213TCA3	10:1	202
	1200	254TC	M750TE12F3P254TCA3	10:1	317
10	1800	215TC	M1000TE18F3P215TCA3	10:1	221
	1200	256TC	M1000TE12F3P256TCA3	10:1	342
15	1800	254TC	M1500TE18F3P254TCA3	10:1	318
	1200	284TC	M1500TE12F3P284TCA3	10:1	532
20	1800	256TC	M2000TE18F3P256TCA3	10:1	397
	1200	286TC	M2000TE12F3P286TCA3	10:1	522
25	1800	284TC	M2500TE18F3P284TCA3	10:1	512
	1200	324TC	M2500TE12F3P324TCA3	10:1	747
30	1800	286TC	M3000TE18F3P286TCA3	10:1	547
	1200	326TC	M3000TE12F3P326TCA3	10:1	777

Motors, Footed, 3 Phase

- Totally enclosed, fan-cooled (TEFC), continuous-duty, 230/460V, 60Hz, 3P.
- 1.15 service factor (1.0 when operated with a VFD).
- Cast Iron construction.
- 10:1 rated motors are NEMA premium efficiency.
- Class “F” insulation with Class “B” rise.
- 50Hz data on nameplate - 190/380V at 1.0 service factor.
- UL recognized with CE mark on label.

HP	RPM	Frame	Part Number	Turndown Ratio (CT)	Shipping Weight (lbs.)
1	1800	143T	M100TE18F3P143TA3	10:1	48
	1200	145T	M100TE12F3P145TA3	10:1	90
	900	182T	M100TE9F3P182TA3	10:1	105
1-1/2	1800	145T	M150TE18F3P145TA3	10:1	78
	1200	182T	M150TE12F3P182TA3	10:1	120
2	1800	145T	M200TE18F3P145TA3	10:1	90
	1200	184T	M200TE12F3P184TA3	10:1	132
	900	213T	M200TE9F3P213TA3	10:1	173
3	1800	182T	M300TE18F3P182TA3	10:1	135
	1200	213T	M300TE12F3P213TA3	10:1	164
5	1800	184T	M500TE18F3P184TA3	10:1	133
	1200	215T	M500TE12F3P215TA3	10:1	210
7-1/2	1800	213T	M750TE18F3P213TA3	10:1	200
	1200	254T	M750TE12F3P254TA3	10:1	315
	900	256T	M750TE9F3P256TA3	10:1	365
10	1800	215T	M1000TE18F3P215TA3	10:1	219
	1200	256T	M1000TE12F3P256TA3	10:1	340
	900	284T	M1000TE9F3P284TA3	10:1	445
15	1800	254T	M1500TE18F3P254TA3	10:1	316
	1200	284T	M1500TE12F3P284TA3	10:1	530
	900	286T	M1500TE9F3P286TA3	10:1	510
20	1800	256T	M2000TE18F3P256TA3	10:1	395
	1200	286T	M2000TE12F3P286TA3	10:1	520
	900	324T	M2000TE9F3P324TA3	10:1	585
25	1800	284T	M2500TE18F3P284TA3	10:1	510
	1200	324T	M2500TE12F3P324TA3	10:1	745
30	1800	286T	M3000TE18F3P286TA3	10:1	545
	1200	326T	M3000TE12F3P326TA3	10:1	775
	900	364T	M3000TE9F3P364TA3	10:1	898
40	1800	324T	M4000TE18F3P324TA3	10:1	710
	1200	364T	M4000TE12F3P364TA3	10:1	945

Motors

Standard Features

- Totally enclosed, fan-cooled, explosion proof, premium efficiency, continuous-duty, 230/460V, 60Hz, 3P.
- Class I, Div. I, Group C & D up to 256T frame; ONLY Group D above 256T frame.
- 1.15 service factor (1.0 when operated with a VFD).
- Cast Iron construction.
- Class “F” insulation.
- NEMA Design B.
- Inverter-duty rated, constant torque.
- Consult factory if operating above 3,300-ft. elevation.
- Consult the National Electric Code and your local regulations for proper selection of motors in hazardous locations.
- UL and CSA listed or certified for hazardous locations.

Motors, NEMA C-Face, Hazardous-duty Location, Explosion Proof, Footed, 3 Phase

HP	RPM	Frame	Part Number	Turndown Ratio (CT)(1)	Shipping Weight (lbs.)
1	1800	143TC	M100EX18F3P143TCA2	4:1	64
2	1800	145TC	M200EX18F3P145TCA2	4:1	80
3	1800	182TC	M300EX18F3P182TCA2	4:1	136
	1200	213TC	M300EX12F3P213TCA2	4:1	240
5	1800	184TC	M500EX18F3P184TCA2	4:1	145
	1200	215TC	M500EX12F3P215TCA2	4:1	235
7-1/2	1800	213TC	M750EX18F3P213TCA2	4:1	200
	1200	254TC	M750EX12F3P254TCA2	4:1	365
10	1800	215TC	M1000EX18F3P215TCA2	4:1	265
	1200	256TC	M1000EX12F3P256TCA2	4:1	420
15	1800	254TC	M1500EX18F3P254TCA2	4:1	390
	1200	284TC	M1500EX12F3P284TCA2	4:1	575
20	1800	256TC	M2000EX18F3P256TCA2	4:1	455
	1200	286TC	M2000EX12F3P286TCA2	4:1	600

(1) Consult factory if higher turndown ratios are required.

Motors, Hazardous-duty Location, Explosion Proof, Footed, 3 Phase

HP	RPM	Frame	Part Number	Turndown Ratio (CT)(1)	Shipping Weight (lbs.)
1	1800	143T	M100EX18F3P143TA2	4:1	64
2	1800	145T	M200EX18F3P145TA2	4:1	80
3	1800	182T	M300EX18F3P182TA2	4:1	136
	1200	213T	M300EX12F3P213TA2	4:1	240
5	1800	184T	M500EX18F3P184TA2	4:1	145
	1200	215T	M500EX12F3P215TA2	4:1	235
7-1/2	1800	213T	M750EX18F3P213TA2	4:1	200
	1200	254T	M750EX12F3P254TA2	4:1	365
10	1800	215T	M1000EX18F3P215TA2	4:1	265
	1200	256T	M1000EX12F3P256TA2	4:1	420
15	1800	254T	M1500EX18F3P254TA2	4:1	390
	1200	284T	M1500EX12F3P284TA2	4:1	575
20	1800	256T	M2000EX18F3P256TA2	4:1	455
	1200	286T	M2000EX12F3P286TA2	4:1	600
25	1800	284T	M2500EX18F3P284TA2	4:1	565
	1200	324T	M2500EX12F3P324TA2	4:1	825
30	1200	326T	M3000EX12F3P326TA2	4:1	787
40	1800	324T	M4000EX18F3P324TA2	4:1	708

(1) Consult factory if higher turndown ratios are required.

Pump Motor Adapters

Pump/Motor Adapters, NEMA

Part Number	Pump Model	Motor Size
A04-005-1200	F22	56C-145TC
A04-001-1202	D03 & D04	56C-145TC
A04-002-1202	D03 & D04	182TC-215TC
A04-001-1200	D10	56C-143/145TC
A04-002-1200	D10	182/184TC-213/215TC
A04-041-1200	D15/D17 & H25	182TC-256TC
A04-041-1202	D15/D17 & H25	284TC-286TC

Note: Dimensional drawings are shown in each pump model section.

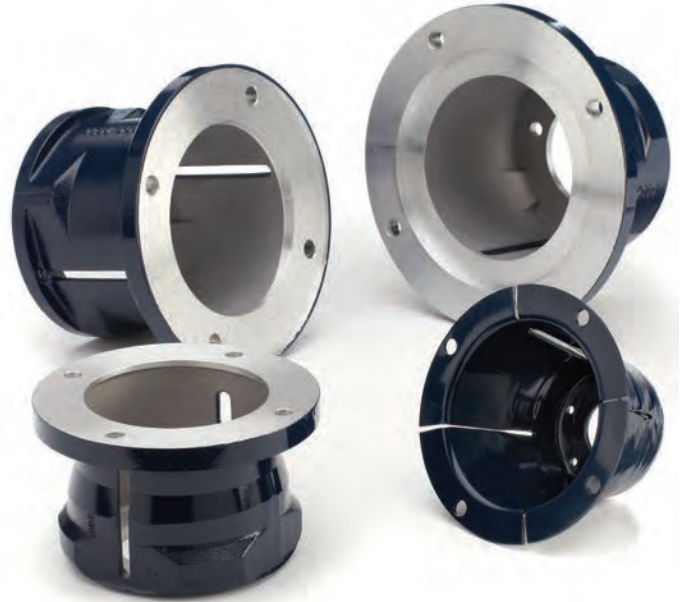

Pump Motor Baseplates and Guards

- Feature heavy-gauge construction.
- Ready to assemble - all mounting holes are fully threaded.
- Complete package includes all mounting hardware, guards, and shims.
- Available for size 56 through 326 NEMA motor frames.
- Choice of blue epoxy-powder-coated steel or Grade 304 Stainless Steel baseplates.
- Pump, motor, adjustable motor base (for HBD Series), coupling, flange adapter, pulleys, and belt ordered separately.
- Customized versions available.

HDD Series

Horizontal Direct Drive with Orange Coupling Guard



Designed for Hydra-Cell models D10, D15, H25 and D35. (D10 shown)

HFD Series

Horizontal Flanged Adapter Drive



Designed for Hydra-Cell models D10, D15 and H25. (D10 shown)

HBD Series

Horizontal Belt Drive with Belt Pulley Guard



Designed for Hydra-Cell models D10, D15, H25 and D35. (D35 shown)

Note: Consult factory for specific model-based drawings and dimensions.

Pump Motor Baseplates and Guards



Required Motor Information		HDD Series Horizontal Direct Drive		HFD Series Horizontal Flanged Adapter Drive		HBD Series Horizontal Belt Drive	
Frame Size	Motor Shaft (in.)	Part Number		Part Number		Part Number	
		Steel	304 SST	Steel	304 SST	Steel	304 SST
D10 Pump Shaft Ø: 7/8" Bases and guards are contour-formed for maximum strength and safety. Steel thickness from 10 to 7 gauge.							
56C	5/8	104-050	104-051	104-052	104-053	104-150	104-151
143T	7/8	104-050	104-051	104-052	104-053	104-150	104-151
145T	7/8	104-050	104-051	104-052	104-053	104-150	104-151
182T	1-1/8	104-000	104-001	104-002	104-003	104-100	104-101
184T	1-1/8	104-000	104-001	104-002	104-003	104-100	104-101
213T	1-3/8	104-030	104-031	104-032	104-033	104-100	104-101
215T	1-3/8	104-030	104-031	104-032	104-033	104-100	104-101
D15 Pump Shaft Ø: 1-1/8" Heavy-duty contour-formed and welded reinforced design. All steel plates 3/16" thick.							
182T	1-1/8	104-830	104-831	104-870	104-871	-	-
184T	1-1/8	104-830	104-831	104-870	104-871	-	-
213T	1-3/8	104-820	104-821	104-860	104-861	104-890	104-891
215T	1-3/8	104-820	104-821	104-860	104-861	104-890	104-891
254T	1-5/8	104-810	104-811	104-850	104-851	104-880	104-881
256T	1-5/8	104-810	104-811	104-850	104-851	104-880	104-881
284T	1-7/8	104-800	104-801	104-840	104-841	-	-
286T	1-7/8	104-800	104-801	104-840	104-841	-	-
H25 Pump Shaft Ø: 1-1/8" Heavy-duty contour-formed and welded reinforced design. All steel plates 3/16" thick.							
143T	7/8	-	-	-	-	104-480	104-481
145T	7/8	-	-	-	-	104-480	104-481
182T	1-1/8	104-350	104-351	104-380	104-381	104-450	104-451
184T	1-1/8	104-350	104-351	104-380	104-381	104-450	104-451
213T	1-3/8	104-375	104-376	104-380	104-381	104-440	104-441
215T	1-3/8	104-375	104-376	104-380	104-381	104-440	104-441
254T	1-5/8	104-330	104-331	104-304	104-309	104-400	104-401
256T	1-5/8	104-330	104-331	104-304	104-309	104-400	104-401
284T	1-7/8	104-300	104-301	104-304	104-309	-	-
286T	1-7/8	104-300	104-301	104-304	104-309	-	-
D35 Pump Shaft Ø: 2" Heavy-duty contour-formed and welded reinforced design. All steel plates 1/4" thick.							
182T	1-1/8	-	-	-	-	104-750	104-751
184T	1-1/8	-	-	-	-	104-750	104-751
213T	1-3/8	104-660	104-661	-	-	104-740	104-741
215T	1-3/8	104-660	104-661	-	-	104-740	104-741
254T	1-5/8	104-650	104-651	-	-	104-730	104-731
256T	1-5/8	104-650	104-651	-	-	104-730	104-731
284T	1-7/8	104-640	104-641	-	-	104-700	104-701
286T	1-7/8	104-640	104-641	-	-	104-700	104-701
324T	2-1/8	104-600	104-601	-	-	-	-
326T	2-1/8	104-600	104-601	-	-	-	-

Hydra-Oil Lubricants

Hydra-Oil is specially formulated to maximize performance of Hydra-Cell pumps:

- Reduce wear.
- Withstand extreme temperature changes.
- Improve pump performance.
- Extend pump life.
- Maintain consistent viscosity.
- Withstand extreme pressures.

Standard Grades

10W30-weight (Order Code A)

For lower temperatures and lighter loads; maintains viscosity over a wide temperature range and with repeated startups.

40-weight (Order Code B)

For continuous use at higher loads and temperatures; provides exceptional wear resistance and film thickness.

Synthetic Grades

Hydra-Oil synthetic grades are a blend of synthesized hydrocarbon fluids that provide pure chemicals and a heavier, more protective oil film for bearings and pistons.

5W30 (Order Code G)

For stable protection in cold temperatures or severe duty.

15W50 (Order Code H)

For stable protection in high temperatures or severe duty.

Food-contact Grade

The Hydra-Oil food contact grade is specially formulated for food service industry applications. Hydra-Oil SFGO grade 100 is USDA H-1 authorized, certified OU Kosher, and complies with the requirements of FDA 21 CFR 178.3570 and FDA 21 CFR 172.882. This lubricant is a polyalphaolephin based synthetic (PAO) and is suggested for use on equipment in which there may be incidental contact with an edible product.

EPDM-compatible Grades

Hydra-Oil EPDM-compatible grades must be used in all Hydra-Cell pumps containing EPDM diaphragms. These CP-100/150 F lubricants are a custom blend of polyalkylene glycols with additives for oxidation stability, corrosion protection, and high-viscosity index. Low solubility with many different hydrocarbons provides for excellent lubricity. Hydra-Oil EPDM-compatible grades are available in 20-weight (Order Code J) and 30/40-weight (Order Code C or D).



Hydra-Oil Characteristics	Standard Grade		Synthetic Grade		Food Grade	EPDM Compatible
	10W30	40W	5W30	15W50	SFGO-100	20W
Order Code Letter	A	B	G	H	E/F or K	J/C/D
Gravity, API @60 °F (16 °C)	31.1	28.7	30.4	30.2	36.9	N/A
Flash Point °F (°C)	400 (204)	430 (221)	445 (229)	470 (243)	450 (232)	500 (260)
Fire Point °F (°C)	440 (227)	470 (243)	N/A	N/A	500 (260)	530 (277)
Pour Point °F (°C)	-30 (-34)	10 (-12)	-65 (-54)	-55 (-48)	-45 (-43)	-40 (-40)
Viscosity: SUS @ 100 °F (38 °C)	360	811	265	556	570	464
	SUS @ 210 °F	63	85	60	90	71
Viscosity Index (99 °)	148	107	165	170	120	223
Specific Gravity	0.88	0.89	N/A	N/A	N/A	0.992

Hydra-Oil Selection Guide

How to Order with Pump Selection

Hydra-Cell pumps are shipped with the oil reservoir filled with the appropriate Hydra-Oil selected by the customer.

1. Use the Hydra-Oil Characteristics chart on page 100 to select the Hydra-Oil best suited to your application requirements.
2. Use the chart below to select the appropriate oil letter code which corresponds to the 12th digit of the pump model ordering number. (Refer to the How to Order page in the appropriate pump product section.)
3. NOTE: All pumps equipped with EPDM diaphragms must use EPDM-compatible oil.

Oil Recommendation

Pump Model	F20 ¹	M03 ²	D04	D10	D12	D15/D17	H25	D35	D66
Oil Reservoir Capacity									
US Quarts	0.125	1.00	1.10	1.10	1.5	2.2	3.3	7.75	8.0
Liters	0.120	0.95	1.05	1.05	1.4	2.1	3.1	7.3	7.5
Metallic Pump Head Material									
Standard-duty	G	A	G	A	A	A	A	A	-
Continuous-duty	G	G	G	B	B	B	B	B	-
Cold-temperature/Severe-duty	G	G	G	G	G	G	G	G	-
High-temperature/Severe-duty	G	G	G	H	G	H	H	H	H
Food-contact	K	K	K	E	E	E	E	E	-
EPDM-compatible	J	J	J	C	C	-	C	D	C
Non-metallic Pump Head Material									
Standard-duty	G	A	-	A	-	-	A	-	-
Continuous-duty	G	G	-	B	-	-	B	-	-
Cold-temperature/Severe-duty	G	G	-	G	-	-	G	-	-
High-temperature/Severe-duty	G	G	-	H	-	-	G	-	H
Food-contact	K	K	-	E	-	-	E	-	-
EPDM-compatible	J	J	-	C	-	-	C	-	C

¹ Includes all F20, F21 and F22 models

² Includes all D03, M03, and M03 Mono-Block models

How to Order Separately

Replacement Hydra-Oil is available in quart and 2-1/2 gallon packages.

1. Consult your Hydra-Cell Pump Installation/Service Manual for oil change interval specifications.
2. Use the part numbers in the chart below.

Code Letter	Oil Description	Quart		2-1/2 Gallon	
		Single	6-Pack	Single	Twin-Pack
A	10W30 for standard-duty	A01-114-3430	A01-114-3431	A01-114-3432	A01-114-3433
B	40-wt for continuous-duty	A01-114-3440	A01-114-3441	A01-114-3442	A01-114-3443
C	30/40-wt EPDM-compatible oil	A01-114-3402	-	A01-114-3403	-
D	30/40-wt EPDM-compatible oil	A01-114-3402	-	A01-114-3403	-
E	Food-contact oil	A01-114-3410	-	A01-114-3411	-
F	Food-contact oil	A01-114-3410	-	A01-114-3411	-
G	5W30 cold-temp severe-duty synthetic oil	A01-114-3415	-	A01-114-3420	-
H	15W50 high-temp severe-duty synthetic oil	A01-114-3416	-	A01-114-3421	-
J	20-wt EPDM-compatible oil	A01-114-3407	-	A01-114-3408	-
K	Food-contact oil	A01-114-3410	-	A01-114-3411	-

Hydraulic Air-cooled Oil Filters

- Reduces wear and tear on the Hydra-Oil to help prolong Hydra-Cell pump life.
- Cools Hydra-Oil from 250°F to 185°F using up to 110°F ambient air.

- Oil cooler capacity of 0.84 gallons @ 1 gpm.*
- Oil cooler capacity of 1.07 gallons @ 2 gpm.*

* Does not include oil volume for inlet and outlet hoses or individual pump capacity.

Gear Pump Options

- 1 gpm for Hydra-Cell Model D03, D04, D10, D15 & H25 pumps.
- 2 gpm Hydra-Cell Model D35, D40, D66, T100 & Q155 pumps.

Assembly Components

- Spin-on oil filter.
- 2-gallon oil reservoir.
- 65-psi check valve.
- 200-psi gauge.
- Dirty filter indicator - holds up to 130 grams of dirt.*
- Inlet: 1/2" NPT.
- Outlet: 1-1/2" NPT.

* Filter replacement using Wanner Engineering's standard motor oil replacement protocol recommended after 500 hours of service.



Air-cooled Oil Filter shown with complete kit.

Part Number	Motor Type	Oil Code	Oil Description
1 gpm Units			
142-500	TE	A	10W30 standard-duty oil
142-501	TE	H	15W50 high-temp severe-duty synthetic oil
142-502	TE	B	40-wt for continuous-duty oil
142-503	TE	E	SFGO-100 Food-contact oil
142-504	TE	D	20W-wt EPDM-compatible oil
142-505	XP	A	10W30 standard-duty oil
142-506	XP	H	15W50 high-temp severe-duty synthetic oil
142-507	XP	B	40-wt for continuous-duty oil
142-508	XP	E	SFGO-100 Food-contact oil
142-509	XP	D	20W-wt EPDM-compatible oil
2 gpm Units			
142-510	TE	A	10W30 standard-duty oil
142-511	TE	H	15W50 high-temp severe-duty synthetic oil
142-512	TE	B	40-wt for continuous-duty oil
142-513	TE	E	SFGO-100 Food-contact oil
142-514	TE	D	20W-wt EPDM-compatible oil
142-515	XP	A	10W30 standard-duty oil
142-516	XP	H	15W50 high-temp severe-duty synthetic oil
142-517	XP	B	40-wt for continuous-duty oil
142-518	XP	E	SFGO-100 Food-contact oil
142-519	XP	D	20W-wt EPDM-compatible oil
Motor Type		Description	
TE		TEFC 230/460V, 60Hz, 3P & 190/380V, 50Hz, 3P: 1/2-hp pump; 1/4-hp fan	
XP		Explosion proof, 230/460V, 60Hz, 3P, DIV 1, Class I Gr. D & Class II Gr. F & G: 1/2-hp pump; 1/4-hp fan	

Hydraulic Water-cooled Oil Filters

- Reduces wear and tear on the Hydra-Oil to help prolong Hydra-Cell pump life.
- Cools Hydra-Oil from 250°F to 185°F using 3 gpm of up to 80°F water.
- Water cooler capacity of approximately 1 quart.*

*Does not include oil volume for inlet and outlet hoses or individual pump capacity.

Gear Pump Options

- 1 gpm for Hydra-Cell Model D03, D04, D10, D15 & H25 pumps.
- 2 gpm Hydra-Cell Model D35, D40, D66, T100 & Q155 pumps.

Assembly Components

- Spin-on oil filter.
- 2-gallon oil reservoir.
- 65-psi check valve.
- 200-psi gauge.
- Dirty filter indicator - holds up to 130 grams of dirt.*
- Water modulating valve.
- Bulb well.
- Inlet: 1/2" NPT.
- Outlet: 1-1/2" NPT.

*Filter replacement using Wanner Engineering's standard motor oil replacement protocol recommended after 500 hours of service.



Water-cooled Oil Filter shown with complete kit.

Part Number	Motor Type	Oil Code	Oil Description
1 gpm Units			
142-600	TE	A	10W30 standard-duty oil
142-601	TE	H	15W50 high-temp severe-duty synthetic oil
142-602	TE	B	40-wt for continuous-duty oil
142-603	TE	E	SFGO-100 Food-contact oil
142-604	TE	D	20W-wt EPDM-compatible oil
142-605	XP	A	10W30 standard-duty oil
142-606	XP	H	15W50 high-temp severe-duty synthetic oil
142-607	XP	B	40-wt for continuous-duty oil
142-608	XP	E	SFGO-100 Food-contact oil
142-609	XP	D	20W-wt EPDM-compatible oil
2 gpm Units			
142-610	TE	A	10W30 standard-duty oil
142-611	TE	H	15W50 high-temp severe-duty synthetic oil
142-612	TE	B	40-wt for continuous-duty oil
142-613	TE	E	SFGO-100 Food-contact oil
142-614	TE	D	20W-wt EPDM-compatible oil
142-615	XP	A	10W30 standard-duty oil
142-616	XP	H	15W50 high-temp severe-duty synthetic oil
142-617	XP	B	40-wt for continuous-duty oil
142-618	XP	E	SFGO-100 Food-contact oil
142-619	XP	D	20W-wt EPDM-compatible oil
Motor Type		Description	
TE		TEFC 230/460V, 60Hz, 3P & 190/380V, 50Hz, 3P: 1/2-hp pump	
XP		Explosion proof, 230/460V, 60Hz, 3P, DIV 1, Class I Gr. D & Class II Gr. F & G: 1/2-hp pump	

Oil Cooler and Filter System

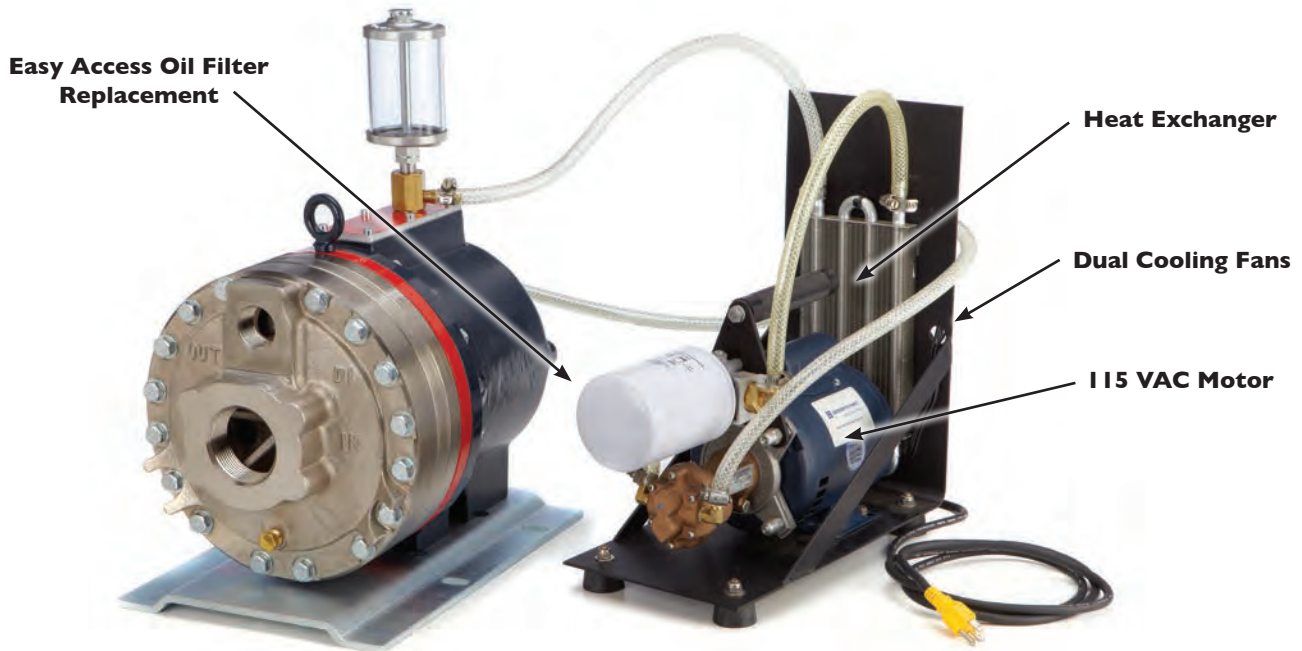

Hydra-Cell Oil Cooler and Filter Systems enable Hydra-Cell pumps to operate cooler in order to extend oil life and reduce bearing wear. This helps maximize performance and reliability in some of the toughest industrial and process applications. They are easy to install and available with all Hydra-Cell models except the F20, P100, MT8, and T & Q Series models. (D35 shown)

- Reduces the typical oil operating temperature by up to 30°F (16°C).
- Lessens the impact of pumping high-temperature fluids.
- Offers greater longevity for pump components when combined with a filtration system built into the cooling loop.
- Extends oil life, reducing the need for oil changes.
- Packaged system includes a hardware kit (see chart) with all necessary fittings, hoses, adapters, hardware, and mounting materials for installation.

Oil Cooler & Filter System

Power	Part Number
60 Hz, 115 VAC	103-100
50 Hz, 230 VAC	103-150

Specify pump when ordering.

Hardware Kits

A Hardware Kit must be ordered when ordering a 103-100 or 103-150 Oil Cooler and Filter System. Select the Hardware Kit based on the pump series below.

Pump	Part Number
D03, D04, D10, D12, P200, P300, P400	103-180
D15, H25, D35, D66, P500, P600	103-175
D17	103-190

Dimensions Inches (mm)

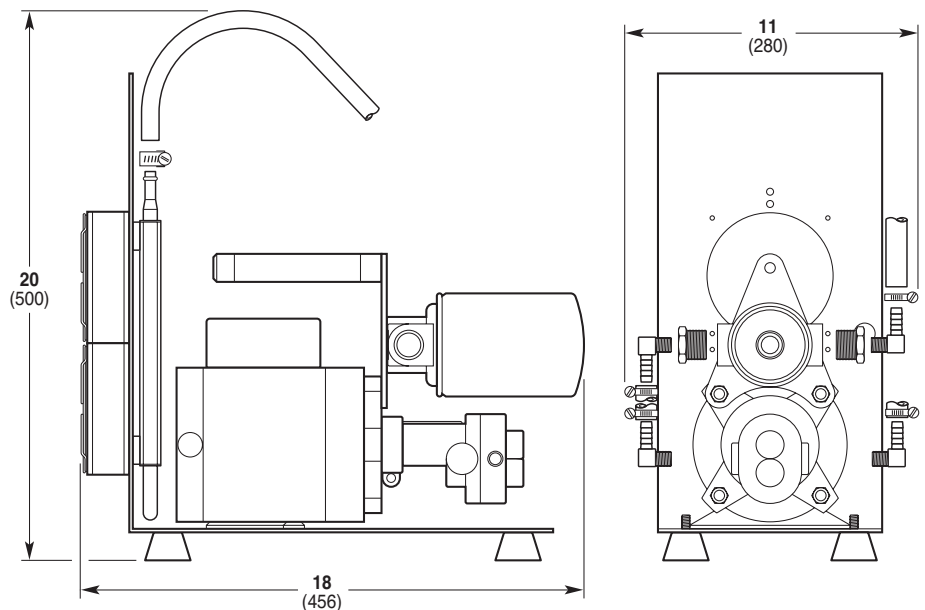

Oil Level Monitoring Mounting Kits

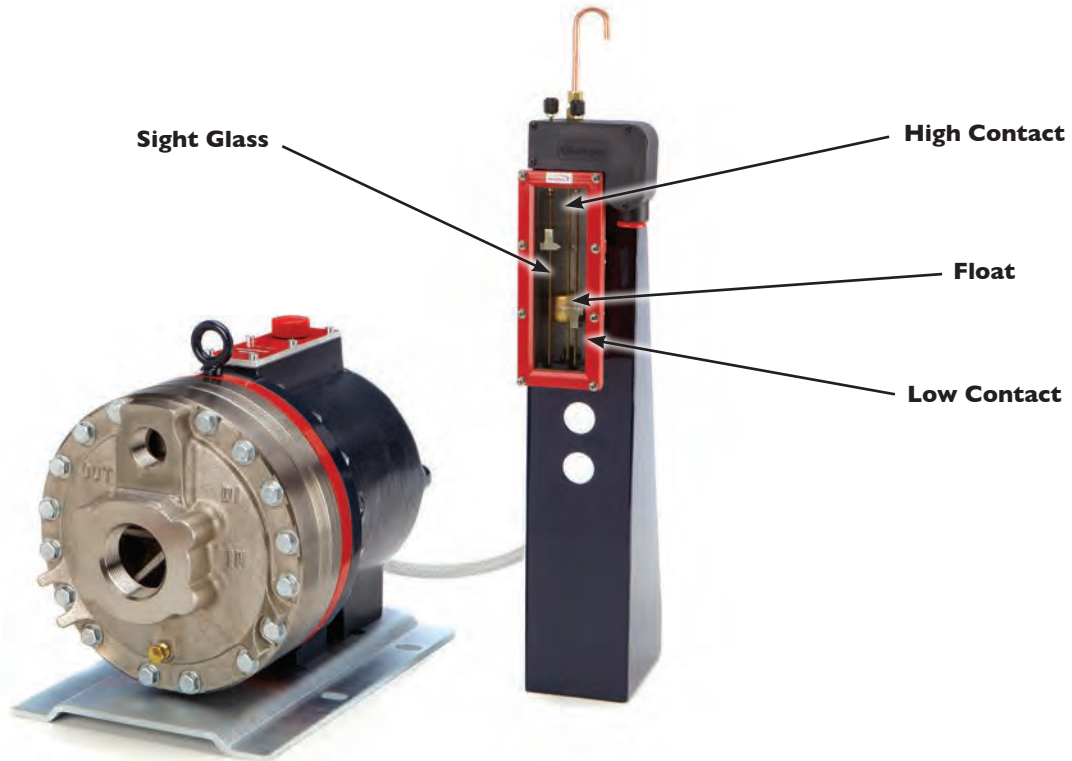

The Hydra-Cell Oil Level Monitoring Kit uses a Murphy SWICHGAGE Model L129CKI, which is field-proven to detect the crank case oil levels and is well-suited to detect oil levels for Hydra-Cell pumps. It is not used with the F20, P100, and T & Q Series models. (D35 shown)

- Detects changes to the oil level in the pump to minimize costly interruptions in the process and avoid potential pump damage
- Ideal for remote or critical industrial applications, such as oil fields, paper mills and automotive plants
- Compact, rugged, and ready to use when supplied with a Murphy SWICHGAGE (ordered separately)
- Adjustable height to accommodate installation options

Oil Level Monitoring Mounting Kit

Description	Part Number
Mounting Kit	103-000
Murphy SWICHGAGE®	103-010

SWICHGAGE® is a registered trademark of Frank W. Murphy MFR.

Oil Level Monitoring Kits are now standard with T & Q Series models. See How to Order on pages 129, 133, and 137 for the T100. See pages 141 and 145 for the Q155. See pages 149 and 153 for the T200. See pages 157 and 161 for the Q330.

Dimensions Inches (mm)

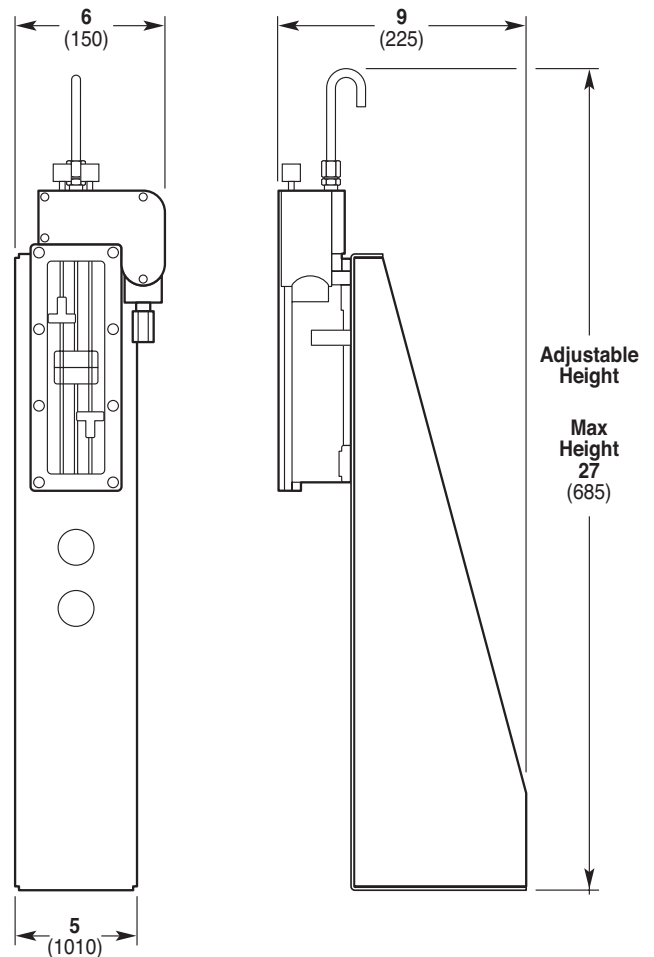

Oil Reservoir Sight Bottles

Oil reservoir assemblies screw in easily where the oil fill cap is located on all Hydra-Cell pumps models except the F20, P100, and T & Q Series models.

Hydra-Cell pumps equipped with an oil reservoir provide additional volume for oil expansion and allow for quick visual monitoring of the oil level and its condition.

Three different bottles are available, including a 12-oz bottle with a low-level float switch that outputs a low voltage signal if the oil level in the pump housing drops.

Bottle Assemblies

Description	Part Number
12-oz (355 ml) volume sight bottle	A01-116-3400
12-oz (355 ml) volume sight bottle with low-level float switch	A01-116-3410
4-oz (119 ml) volume sight bottle	A01-116-3500



Vacuum Priming Kit

The Hydra-Cell Vacuum Priming Kit provides for a quick and easy way to prime the hydraulic pistons after diaphragm replacement. The tool assembly is attached to the hydraulic end housing through the oil cap and pulls a vacuum, removing air from behind the diaphragms. Priming can be accomplished while the pump remains in place.

Description	Part Number
Vacuum Priming Kit	A03-130-1200



Priming Plugs

PVC priming plugs are used to assist in priming the hydraulic cells in Hydra-Cell pumps equipped with Kel-Cell technology. They are available in a variety of sizes with and without air valves.

Description	Part Number
NPT, solid 3/4"	A03-100-0000
NPT, solid 1"	A03-100-0001
NPT, solid 1-1/4"	A03-100-0002
NPT, solid 1-1/2"	A03-100-0003
NPT, solid 2-1/2"	A03-100-0004
NPT, solid 3/4", with air valve	A03-100-0040
NPT, solid 1", with air valve	A03-100-0041
NPT, solid 1-1/4", with air valve	A03-100-0042
NPT, solid 1-1/2", with air valve	A03-100-0043
NPT, solid 2-1/2", with air valve	A03-100-0044
BSPT, solid 2-1/2", with air valve	A03-100-0144



Tool Kits



Complete Tool Kits

Customized for your specific pump model, Hydra-Cell Tool Kits provide specialty tools to facilitate maintenance and servicing of your Hydra-Cell pump. Each kit is packaged in a durable plastic case and includes a shaft rotator, valve seat remover, plunger guide lifter, plunger holder, protector seal, seal inserter, and assembly studs.

Pump Model	Tool Kit Part Number
Master Tool Kit for all Pump Models	A03-175-1107
F20, F21, F22	A03-175-1105
M03, D03, D04	A03-175-1106
D10, D12	A03-175-1101
D15/D17	A03-175-1103
H25	A03-175-1102
D35	A03-200-1100
D40/D66	A03-191-1100
T100 & Q155 Low Pressure	177-811
T100 & Q155 Medium Pressure	177-800
T100 High Pressure	177-807
T200 Medium Pressure	211-800
T200 Crankshaft	211-812

Note: Since Mono-Block pumps feature the valve plate and manifold combined into one component for servicing, consult factory regarding tool kit needs.

Specialty Tools

For your convenience individual specialty tools are available for all Hydra-Cell pumps.

Ref #	Part Number	Description
1	A03-126-1500	Toolbox
2	A03-159-1200	Inserter/Rotator (D10)
	A03-160-1200	Inserter/Rotator (D15/D17, H25)
	A03-185-1200	Inserter/Rotator (D35, D40, D66)
3	A03-124-1200	Lever Assembly
4	A03-117-1000	Seat Puller (M03, D03, D04)
	A03-118-1000	Seat Puller (D10, D12)
	A03-119-1000	Seat Puller (H25, D35)
5	A03-157-1000	Seal Protector (D10, D12)
	A03-158-1002	Seal Protector (D15/D17)
	A03-158-1001	Seal Protector (H25)
6	A03-125-1020	Plunger Holder (F20, M03, D03, D04)
	A03-125-1010	Plunger Holder (D10, D12, D15/D17)
	A03-125-1000	Plunger Holder (H25, D35)
	A03-125-1030	Plunger Holder (D40, D66)
7	A03-195-1200	Shaft Rotator (F20, M03, D03, D04)
8	A03-196-1000	Plunger Guide Lifter (F20, M03, D03, D04)
9	A03-162-1200	Plunger Guide Lifter (D10, D12)
	A03-162-1201	Plunger Guide Lifter (H25, D35)
	A03-162-1202	Plunger Guide Lifter (D40, D66)
10	A03-156-1200	Assembly Studs (D10, D12, D15/D17, H25, D35, D40, D66)
	A03-182-1200	Seat Removal Tool (D40, D66)

Replacement Parts Kits

Convenient replacement part kits for all models of Hydra-Cell pumps are prepackaged with all necessary components to make pump service quick and easy.

Three types of kits are available depending on the level of replacement service required:

- Diaphragm Kit
- Valve Kit
- Complete Fluid-end Kit

Every kit has the correct components matching your specific pump configuration and materials (based on your original model number designed in Order Code Digits 7, 8, 9, 10 & 11). Contact us or your Hydra-Cell distributor to select your correct kit.



Replacement Hydraulic Ends

Complete hydraulic end assemblies are available as replacement items. The hydraulic end contains all drive end components from the drive shaft up to and including the diaphragms. All hydraulic ends are factory-tested and shipped with oil. To order a replacement hydraulic end, refer to the appropriate pump ordering page and specify the desired cam, diaphragm and o-ring material, and Hydra-Oil.

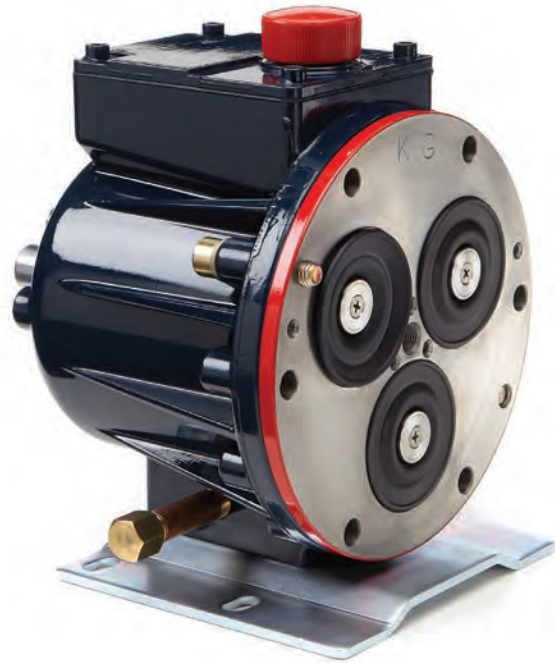

Controllers

Controllers regulate the motor speed and strokes per minute, providing a flow that is proportional to the motor speed.

Selection Process

1. Ensure that the phase and enclosure match your application.
2. Using the appropriate chart below, select the controller hp based on the hp of your motor.
3. Match the output voltage to the output voltage of your motor.
4. Match the input voltage to your electrical source.



1 Phase

HP	Type	Input Voltage/Phase	Output Voltage/Phase	Enclosure	Part Number	Weight (lbs.)
1/2	Sensorless Vector	230 volt / 1-phase	230 volt / 3-phase	NEMA 1	C50N1-1P3P-230	2.2
1	Sensorless Vector	115 volt / 1-phase	230 volt / 3-phase	IP-20	C100IP-1P3P-115	3.5
1	Micro AC Inverter	115 volt / 1-phase	230 volt / 3-phase	NEMA 4	C100N4-1P3P-115	8.0
1	Sensorless Vector	230 volt / 1-phase	230 volt / 3-phase	NEMA 1	C100N1-1P3P-230	2.2
1	Sensorless Vector	230 volt / 1-phase	230 volt / 3-phase	NEMA 4	C100N4-1P3P-230	8.0
2	Sensorless Vector	230 volt / 1-phase	230 volt / 3-phase	NEMA 1	C200N1-1P3P-230	4.4
3	Sensorless Vector	230 volt / 1-phase	230 volt / 3-phase	NEMA 1	C300N1-1P3P-230	4.4

3 Phase

HP	Type	Input Voltage/Phase	Output Voltage/Phase	Enclosure	Part Number	Weight (lbs.)
1/2	Sensorless Vector	230 volt / 3-phase	230 volt / 3-phase	NEMA 1	C50N1-3P3P-230	2.2
1	Sensorless Vector	230 volt / 3-phase	230 volt / 3-phase	NEMA 1	C100N1-3P3P-230	2.2
2	Sensorless Vector	230 volt / 3-phase	230 volt / 3-phase	NEMA 1	C200N1-3P3P-230	4.4
2	Sensorless Vector	230 volt / 3-phase	230 volt / 3-phase	NEMA 4	C200N4-3P3P-230	14.0
3	Sensorless Vector	230 volt / 3-phase	230 volt / 3-phase	NEMA 1	C300N1-3P3P-230	4.4
5	Sensorless Vector	230 volt / 3-phase	230 volt / 3-phase	NEMA 1	C500N1-3P3P-230	5.0
7-1/2	Sensorless Vector	230 volt / 3-phase	230 volt / 3-phase	NEMA 1	C750N1-3P3P-230	13.0
10	Sensorless Vector	230 volt / 3-phase	230 volt / 3-phase	NEMA 1	C1000N1-3P3P-230	13.0
1	Sensorless Vector	460 volt / 3-phase	460 volt / 3-phase	NEMA 1	C100N1-3P3P-460	2.2
1	Sensorless Vector	460 volt / 3-phase	460 volt / 3-phase	NEMA 4	C100N4-3P3P-460	13.0
2	Sensorless Vector	460 volt / 3-phase	460 volt / 3-phase	NEMA 1	C200N1-3P3P-460	2.2
2	Sensorless Vector	460 volt / 3-phase	460 volt / 3-phase	NEMA 4	C200N4-3P3P-460	14.0
3	Sensorless Vector	460 volt / 3-phase	460 volt / 3-phase	NEMA 1	C300N1-3P3P-460	4.4
5	Sensorless Vector	460 volt / 3-phase	460 volt / 3-phase	NEMA 1	C500N1-3P3P-460	4.4
7-1/2	Sensorless Vector	460 volt / 3-phase	460 volt / 3-phase	NEMA 1	C750N1-3P3P-460	14.0
10	Sensorless Vector	460 volt / 3-phase	460 volt / 3-phase	NEMA 1	C1000N1-3P3P-460	14.0
15	Sensorless Vector	460 volt / 3-phase	460 volt / 3-phase	NEMA 1	C1500N1-3P3P-460	14.0
20	Sensorless Vector	460 volt / 3-phase	460 volt / 3-phase	NEMA 1	C2000N1-3P3P-460	28.0
30	Sensorless Vector	460 volt / 3-phase	460 volt / 3-phase	NEMA 1	C3000N1-3P3P-460	30.0
40	Sensorless Vector	460 volt / 3-phase	460 volt / 3-phase	NEMA-1	C400N1-3P3P-460	70.0

Control Freak™ Electronic Metering Controller

Control Freak™

Control Freak is an exclusive new electronic controller that provides motor speed control for Hydra-Cell Metering Solutions pumps (or Hydra-Cell bare shaft pumps for metering). It features built-in programming and is available in a web-based format or with an easy-to-use touch-screen display.

The user can enter the desired flow rate or volume in gallons or liters and system pressure in psi or bar, and the controller automatically runs the pump manually at the desired flow rate or volume total/time, or in pre-set batches.

This versatile electronic controller allows programming for the flow rate or for totalization of the recent process application as well as the life of the pump.



Start-up menu for the touch-screen model.

Touch-screen Exclusives:

- 7" color graphic touch-screen user interface in a NEMA-4X enclosure - easy to operate and visible in low-light areas.
- Safety features for emergency stop, loss of power and fault monitoring.
- Can control up to six (6) pumps with one Hydra-Cell Control Freak screen - requires additional VFDs and I/O modules.

Performance Features

- Variable Frequency Drive (VFD).
- Pre-set (with password protection) for Hydra-Cell pump performance algorithms - can also be field-calibrated for greater accuracy.
- Input for temperature probe monitoring.
- Pump-drive information screen.
- Four configurable on-off relays.
- Ten separate batch set-up screens per pump.
- Two user-configurable analog input displays.
- Analog and digital I/O for interfacing with external devices.
- One analog input dedicated to a pre-programmed closed loop feedback.
- Includes real-time clock.
- Emergency stop safety feature.
- Versatile - enables programming for flow rate or totalization.

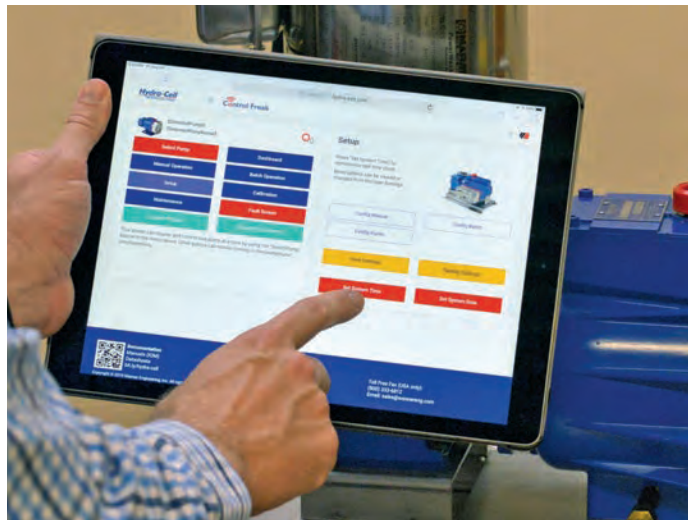

Web-based version operating from a tablet.

Web-based Exclusives:

- Accessible through phone/mobile devices, tablets, laptops, and desktops.
- Can control an unlimited number of Hydra-Cell metering pumps - requires additional VFDs and I/O modules.
- Two-pump proportioning.
- Inputs for leak detection and oil level monitoring.
- Maintenance reminders.
- Updates through thumb drive.

Control Freak Selection Process

Programming Options

- Touch-screen: Includes 7" screen with assembly cable, CAT5e, 7-ft.
- Web-based: For phone/mobile, tablet, and laptop/desktop computers.



Touch-screen shown with required VFD kit.
The Web-based program also uses a VFD kit.

VFD Kits (order one VFD kit for each pump operated by the Control Freak)

Power	Type	Input Voltage/Phase	Output Voltage/Phase
1/2 hp (0.37 kW)	VFD	115 volt/1-phase	230/460 volt/3-phase
1/2 hp (0.37 kW)	VFD	230 volt/1-phase	230/460 volt/3-phase
1 hp (0.75 kW)	VFD	115 volt/1-phase	230/460 volt/3-phase
1 hp (0.75 kW)	VFD	230 volt/1-phase	230/460 volt/3-phase
2 hp (1.5 kW)	VFD	230 volt/1-phase	230/460 volt/3-phase
3 hp (2.2 kW)	VFD	230 volt/1-phase	230/460 volt/3-phase
1/2 hp (0.37 kW)	VFD	230 volt/3-phase	230/460 volt/3-phase
1 hp (0.75 kW)	VFD	230 volt/3-phase	230/460 volt/3-phase
2 hp (1.5 kW)	VFD	230 volt/3-phase	230/460 volt/3-phase
3 hp (2.2 kW)	VFD	230 volt/3-phase	230/460 volt/3-phase
1 hp (0.75 kW)	VFD	460 volt/3-phase	230/460 volt/3-phase
2 hp (1.5 kW)	VFD	460 volt/3-phase	230/460 volt/3-phase
3 hp (2.2 kW)	VFD	460 volt/3-phase	230/460 volt/3-phase

For higher hp or kW, please consult factory.

Each VFD kit includes:

- Appropriate VFD model in chart to left
- I/O Module, Single Pump
- Wiring, I/O Module
- Wiring, Motor, 22 ga., 1-ft., Red
- Wiring, Motor, 22 ga., 1-ft., White
- Cable, CAT5e, 1-ft.

Control Freak Accessories

Accessory	Description
Enclosure (1)	VFD Enclosure for up to 1 hp (0.75 kW)
Probe Kit	Oil Temperature Sensor Probe with Oil Cap
Ball Mount Assembly (2)	Bracket Ball, Ball Mount Hinge, Screw, Nut
Emergency Stop Button (3)	Safety Kit
Cabling	1-ft. CAT5e Cable
Cabling	3-ft. CAT5e Cable
Cabling	7-ft. CAT5e Cable
Cabling	10-ft. CAT5e Cable
Cabling	30-ft. CAT5e Cable

(1) Consult Factory for larger VFDs and for pricing on equipment mounting in enclosure.

(2) Available for Touch-screen model only.

(3) Available as an accessory for Web-based version only; built into Touch-screen model.



Calibration Cylinders

The calibration cylinder verifies the flow rate of your Hydra-Cell metering pump, providing a visual indicator that your system is operating within the required parameters for performance and accuracy.

Available in PVC and glass, calibration cylinders are selected based on cylinder capacity needed (gph or lph) as determined by the maximum shaft rpm of your pump. Models are available for both NPT and BSPT ports.

Selection Process

1. Size the appropriate Hydra-Cell pump model to the application. (Refer to the metering pump section starting on page 162 for more information.)
2. Use the application rpm to select the appropriate cylinder from the chart below.



Cylinder Size mL	30	200	300	1000	2000	10000
Capacity gph (lph)	0.95 (3.6)	6.4 (24)	9.5 (36)	32 (120)	64 (240)	320 (1200)
Maximum Pump Shaft (rpm)						
MT8	36	250	360	-	-	-
P100 (F20)	30	180	250	1000	1750	-
P200 (M03)	-	60	90	300	600	1750
P300 (D04)	-	60	90	300	600	1750
P400 (D10)	-	30	40	110	210	1000
P500 (D15/D17)	-	-	-	60	115	600
P600 (H25)	-	-	-	30	60	275

Port C	Cylinder Size (mL)	Part Number		Dimensions - in (mm)	
		NPT Ports	BSPT Ports	A	B
PVC Cylinders					
1/2"	200	111-001	111-001-B	19.0 (482.6)	1.5 (38.1)
1/2"	300	111-002	111-002-B	13.0 (330.2)	2.2 (55.9)
3/4"	1000	111-003	111-003-B	22.0 (558.8)	2.5 (63.5)
1"	2000	111-004	111-004-B	20.0 (508.0)	3.7 (94.0)
2"	10000	111-006	111-006-B	25.0 (635.0)	6.95 (176.5)
Glass Cylinders					
1/4"	30	111-010	111-010-B	14.0 (355.6)	1.4 (35.6)
1/2"	200	111-011	111-011-B	21.0 (533.4)	2.5 (63.5)
3/4"	1000	111-013	111-013-B	27.0 (685.8)	3.5 (88.9)
1"	2000	111-014	111-014-B	27.0 (685.8)	5.0 (127.0)

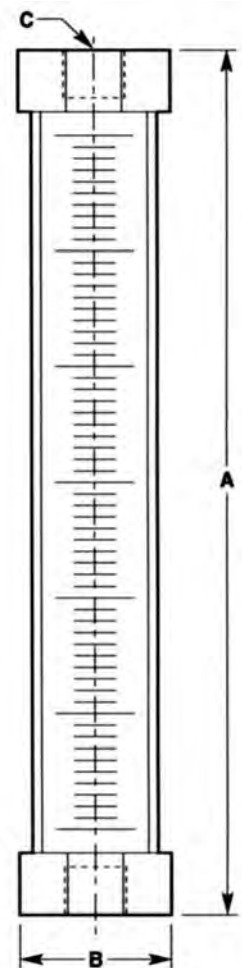

Back Pressure and Pressure Relief Valves

Back pressure valves help ensure that your Hydra-Cell metering pump provides accurate and predictable flow. Pressure relief valves protect your pump and system from over-pressurized situations.

Available in a choice of wetted materials with PTFE diaphragms, pressure valves are selected according to the valve port size needed for the appropriate maximum flow (gph or lph) of your Hydra-Cell metering pump. Models are available for both NPT and BSPT ports.



Dimensions and Port Configurations

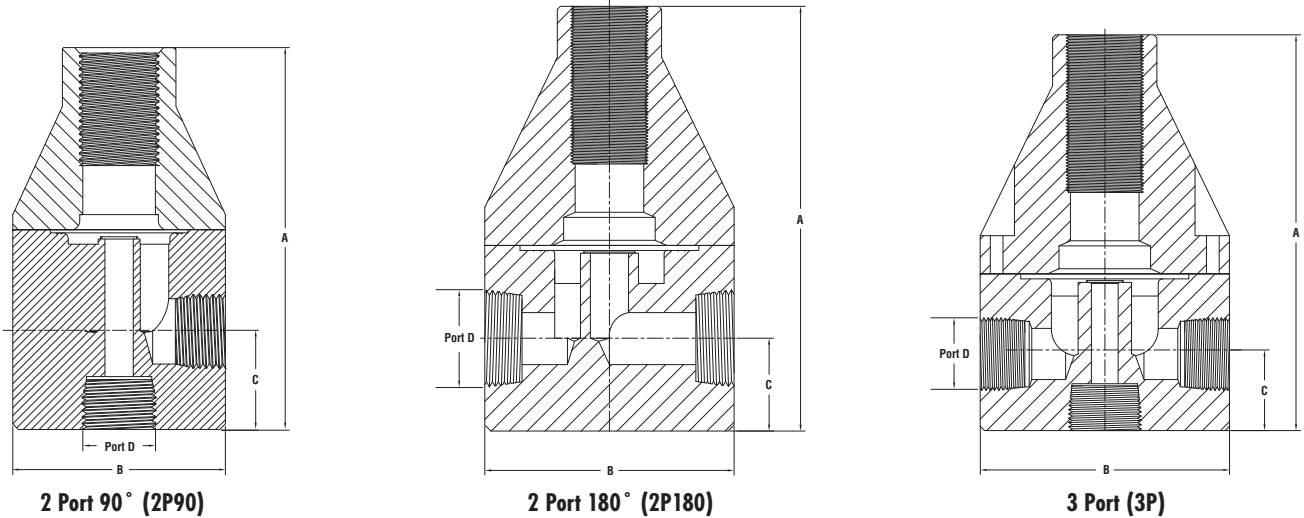

Material	Port D	A		B		C	
		in	mm	in	mm	in	mm
Polypropylene/PVDF	3/8" (DN 10) LoFlo	3.55	90.2	2.35	59.7	0.75	19.1
	1/2" (DN 15) LoFlo	4.25	108.0	2.35	59.7	1.08	27.4
	3/4" (DN 20)*	5.56	141.2	3.50	88.9	1.125	28.6
	1" (DN 25) StdFlo	5.86	148.8	3.50	88.9	1.25	31.8
	1" (DN 25) HiFlo	7.25	184.2	4.90	124.5	1.25	31.8
	2" (DN 50) StdFlo	8.90	226.1	4.90	124.5	2.15	54.6
316 SST	1/4" (DN 8) High Pressure	4.25	108.0	2.35	59.7	1.08	27.4
	1/4" (DN 8) Super High Pressure (HP)	4.72	119.9	2.375	60.3	1.08	27.4
	3/8" (DN 10) LoFlo	3.55	90.2	2.35	59.7	0.75	19.1
	3/8" (DN 10) High Pressure	4.25	108.0	2.35	59.7	1.08	27.4
	1/2" (DN 15) LoFlo	4.25	108.0	2.35	59.7	1.08	27.4
	1/2" (DN 15) High Pressure	4.25	108.0	2.35	59.7	1.08	27.4
	1/2" (DN 15) Super High Pressure (HP)	4.72	119.9	2.375	60.3	1.08	27.4
	3/4" (DN 20)*	5.56	141.2	3.50	88.9	1.125	28.6
	1" (DN 25) StdFlo	5.86	148.8	3.50	88.9	1.25	31.8
	1" (DN 25) HiFlo	7.25	184.2	4.90	124.5	1.25	31.8
	1" (DN 25) High Pressure	5.90	149.9	3.50	88.9	1.25	31.8
	2" (DN 50) StdFlo	8.90	226.1	4.90	124.5	2.15	54.6
Hastelloy C	1/4" (DN 8) High Pressure	4.25	108.0	2.35	59.7	1.08	27.4
	1/4" (DN 8) Super High Pressure (HP)	4.72	119.9	2.375	60.3	1.08	27.4
	3/8" (DN 10) LoFlo	3.55	90.2	2.35	59.7	0.75	19.1
	3/8" (DN 10) High Pressure	4.25	108.0	2.35	59.7	1.08	27.4
	1/2" (DN 15) LoFlo	4.25	108.0	2.35	59.7	1.08	27.4
	1/2" (DN 15) High Pressure	4.25	108.0	2.35	59.7	1.08	27.4
	1/2" (DN 15) Super High Pressure (HP)	4.72	119.9	2.375	60.3	1.08	27.4
	3/4" (DN 20)*	5.56	141.2	3.50	88.9	1.125	28.6
	1" (DN 25) StdFlo	5.86	148.8	3.50	88.9	1.25	31.8
	1" (DN 25) HiFlo	7.25	184.2	4.90	124.5	1.25	31.8
	1" (DN 25) High Pressure	5.90	149.9	3.50	88.9	1.25	31.8
	2" (DN 50) StdFlo	8.90	226.1	4.90	124.5	2.15	54.6

* 3/4" (DN 20) dimensions apply to StdFlo, HiFlo, and High Pressure models.

Back Pressure Valves

Selection Process

1. Use the Valve Port Size “D” chart below to determine the valve port size with the appropriate maximum flow rate to match the Hydra-Cell pump selected: gpm and l/min are Continuous Flow; gph and lph are Pulsating Flow.
 2. For Back Pressure Valves, use the lower chart on this page to select the appropriate valve. For Pressure Relief Valves, use the chart on the following page.
- (Note: The maximum flow rates are guidelines. Consult factory for specific recommendations.)

Valve Port Size “D”

		LoFlo		StdFlo			HiFlo		High Pressure		Super High Pressure
		3/8" (DN 10)	1/2" (DN 15)	3/4" (DN 20)	1" (DN 25)	2" (DN 50)	3/4" (DN 20)	1" (DN 25)	1/4"-3/8"-1/2" (DN 8/DN 10/DN 15)	3/4"-1" (DN 20/DN 25)	1/4"-1/2" (DN 8/DN 10)
Continuous	gpm	10	15	21	26	120	30	54	35	60	56
	l/min	37	57	80	98	454	114	204	132	227	212
Pulsating	gph	200	300	300	500	2350	600	1000	700	1200	1050
	lph	757	1135	1135	1890	8892	2271	3785	2650	4542	3975

Pulsating recommended for single-diaphragm, low-flow pumps (F20 Series and P100).

Port “D”	Wetted Materials*	Pressure Adjustment Range		Maximum Temperature		Port Configuration	Part Number	
		psi	bar	°F	°C		NPT Ports	BSPT Ports
3/8" (DN 10) LoFlo	Polypropylene	10 - 150	0.7 - 10.3	195	90	2P180	111-101	111-101-B
	PVDF	10 - 150	0.7 - 10.3	300	149	2P180	111-103	111-103-B
	316 SST	10 - 150	0.7 - 10.3	300	149	2P180	111-106	111-106-B
	Hastelloy C	10 - 150	0.7 - 10.3	300	149	2P180	111-110	111-110-B
	316 SST	50 - 350	3.5 - 24	300	149	2P180	111-107	111-107-B
	Hastelloy C	50 - 350	3.5 - 24	300	149	2P180	111-111	111-111-B
1/2" (DN 15) LoFlo	Polypropylene	10 - 150	0.7 - 10.3	195	90	2P180	111-121	111-121-B
	PVDF	10 - 150	0.7 - 10.3	300	149	2P180	111-123	111-123-B
	316 SST	10 - 150	0.7 - 10.3	300	149	2P180	111-126	111-126-B
	Hastelloy C	10 - 150	0.7 - 10.3	300	149	2P180	111-130	111-130-B
	316 SST	50 - 350	3.5 - 24	300	149	2P180	111-127	111-127-B
	Hastelloy C	50 - 350	3.5 - 24	300	149	2P180	111-131	111-131-B
3/4" (DN 20) StdFlo	Polypropylene	10 - 150	0.7 - 10.3	195	90	2P180	111-341	111-341-B
	PVDF	10 - 150	0.7 - 10.3	300	149	2P180	111-343	111-343-B
	316 SST	10 - 150	0.7 - 10.3	300	149	2P180	111-346	111-346-B
	Hastelloy C	10 - 150	0.7 - 10.3	300	149	2P180	111-350	111-350-B
1" (DN 25) StdFlo	Polypropylene	10 - 150	0.7 - 10.3	195	90	2P180	111-261	111-261-B
	PVDF	10 - 150	0.7 - 10.3	300	149	2P180	111-263	111-263-B
	316 SST	10 - 150	0.7 - 10.3	300	149	2P180	111-266	111-266-B
	Hastelloy C	10 - 150	0.7 - 10.3	300	149	2P180	111-270	111-270-B
	316 SST	50 - 350	3.5 - 24	300	149	2P180	111-267	111-267-B
	Hastelloy C	50 - 350	3.5 - 24	300	149	2P180	111-271	111-271-B
1" (DN 25) HiFlo	Polypropylene	10 - 150	0.7 - 10.3	195	90	2P180	111-361	111-361-B
	PVDF	10 - 150	0.7 - 10.3	300	149	2P180	111-363	111-363-B
	316 SST	10 - 150	0.7 - 10.3	300	149	2P180	111-366	111-366-B
	Hastelloy C	10 - 150	0.7 - 10.3	300	149	2P180	111-370	111-370-B
2" (DN 50) StdFlo	Polypropylene	10 - 150	0.7 - 10.3	195	90	2P180	111-281	111-281-B
	PVDF	10 - 150	0.7 - 10.3	300	149	2P180	111-283	111-283-B
	316 SST	10 - 150	0.7 - 10.3	300	149	2P180	111-286	111-286-B
	Hastelloy C	10 - 150	0.7 - 10.3	300	149	2P180	111-290	111-290-B
	316 SST	50 - 350	3.5 - 24	300	149	2P180	111-287	111-287-B
	Hastelloy C	50 - 350	3.5 - 24	300	149	2P180	111-291	111-291-B

* Diaphragm material is PTFE on all models. Other materials available on request.

Pressure Relief Valves

Port "D"	Wetted Materials*	Pressure Adjustment Range		Maximum Temperature		Port Configuration	Part Number	
		psi	bar	° F	° C		NPT Ports	BSPT Ports
1/4" (DN 8)	316 SST	350 - 2500	24 - 172	300	149	2P90	111-800	111-800-B
High Pressure	Hastelloy C	350 - 2500	24 - 172	300	149	2P90	111-804	111-804-B
1/4" (DN 8)	316 SST	1000 - 4000	69 - 275	300	149	2P90	111-780	111-780-B
Super HP	Alloy 20	1000 - 4000	69 - 275	300	149	2P90	111-781	111-781-B
	Hastelloy C	1000 - 4000	69 - 275	300	149	2P90	111-782	111-782-B
3/8" (DN 10)	Polypropylene	10 - 150	0.7 - 10.3	195	90	3P	111-401	111-401-B
LoFlo	PVDF	10 - 150	0.7 - 10.3	300	149	3P	111-403	111-403-B
	316 SST	10 - 150	0.7 - 10.3	300	149	3P	111-406	111-406-B
	Hastelloy C	10 - 150	0.7 - 10.3	300	149	3P	111-410	111-410-B
	316 SST	50 - 350	3.5 - 24	300	149	3P	111-407	111-407-B
	Hastelloy C	50 - 350	3.5 - 24	300	149	3P	111-411	111-411-B
3/8" (DN 10)	316 SST	350 - 2500	24 - 172	300	149	2P90	111-706	111-706-B
High Pressure	Hastelloy C	350 - 2500	24 - 172	300	149	2P90	111-710	111-710-B
1/2" (DN 15)	Polypropylene	10 - 150	0.7 - 10.3	195	90	3P	111-421	111-421-B
LoFlo	PVDF	10 - 150	0.7 - 10.3	300	149	3P	111-423	111-423-B
	316 SST	10 - 150	0.7 - 10.3	300	149	3P	111-426	111-426-B
	Hastelloy C	10 - 150	0.7 - 10.3	300	149	3P	111-430	111-430-B
	316 SST	50 - 350	3.5 - 24	300	149	3P	111-427	111-427-B
	Hastelloy C	50 - 350	3.5 - 24	300	149	3P	111-431	111-431-B
1/2" (DN 15)	316 SST	350 - 2500	24 - 172	300	149	2P90	111-726	111-726-B
High Pressure	Hastelloy C	350 - 2500	24 - 172	300	149	2P90	111-730	111-730-B
1/2" (DN 15)	316 SST	1000 - 4000	69 - 275	300	149	2P90	111-783	111-783-B
Super HP								
3/4" (DN 20)	Polypropylene	10 - 150	0.7 - 10.3	195	90	3P	111-541	111-541-B
StdFlo	PVDF	10 - 150	0.7 - 10.3	300	149	3P	111-543	111-543-B
	316 SST	10 - 150	0.7 - 10.3	300	149	3P	111-546	111-546-B
	Hastelloy C	10 - 150	0.7 - 10.3	300	149	2P180	111-550	111-550-B
	316 SST	50 - 350	3.5 - 24	300	149	2P180	111-547	111-547-B
3/4" (DN 20)	Polypropylene	10 - 150	0.7 - 10.3	195	90	2P180	111-641	111-641-B
HiFlo	PVDF	10 - 150	0.7 - 10.3	300	149	2P180	111-643	111-643-B
	316 SST	10 - 150	0.7 - 10.3	300	149	2P180	111-646	111-646-B
	Hastelloy C	10 - 150	0.7 - 10.3	300	149	2P180	111-650	111-650-B
3/4" (DN 20)	316 SST	350 - 2500	24 - 172	300	149	2P90	111-746	111-746-B
High Pressure	Hastelloy C	350 - 2500	24 - 172	300	149	2P90	111-750	111-750-B
1" (DN 25)	Polypropylene	10 - 150	0.7 - 10.3	195	90	3P	111-561	111-561-B
StdFlo	PVDF	10 - 150	0.7 - 10.3	300	149	3P	111-563	111-563-B
	316 SST	10 - 150	0.7 - 10.3	300	149	3P	111-566	111-566-B
	Hastelloy C	10 - 150	0.7 - 10.3	300	149	2P180	111-570	111-570-B
	316 SST	50 - 350	3.5 - 24	300	149	3P	111-567	111-567-B
	Hastelloy C	50 - 350	3.5 - 24	300	149	2P180	111-571	111-571-B
1" (DN 25)	Polypropylene	10 - 150	0.7 - 10.3	195	90	2P180	111-661	111-661-B
HiFlo	PVDF	10 - 150	0.7 - 10.3	300	149	2P180	111-663	111-663-B
	316 SST	10 - 150	0.7 - 10.3	300	149	2P180	111-666	111-666-B
	Hastelloy C	10 - 150	0.7 - 10.3	300	149	2P180	111-670	111-670-B
1" (DN 25)	316 SST	350 - 2500	24 - 172	300	149	2P90	111-766	111-766-B
High Pressure	Hastelloy C	350 - 2500	24 - 172	300	149	2P90	111-770	111-770-B
2" (DN 50)	Polypropylene	10 - 150	0.7 - 10.3	195	90	2P90	111-581	111-581-B
StdFlo	PVDF	10 - 150	0.7 - 10.3	300	149	2P180	111-583	111-583-B
	316 SST	10 - 150	0.7 - 10.3	300	149	2P180	111-586	111-586-B
	Hastelloy C	10 - 150	0.7 - 10.3	300	149	2P180	111-590	111-590-B
	316 SST	50 - 350	3.5 - 24	300	149	2P180	111-587	111-587-B
	Hastelloy C	50 - 350	3.5 - 24	300	149	2P180	111-591	111-591-B

* Diaphragm material is PTFE on all models. Other materials available on request.

Pulsation Dampeners

Pulsation dampeners protect your pumping system and its components by removing virtually all hydraulic shock and vibration resulting from the reciprocating stroking action of a positive displacement pump.

They control pulsations by allowing fluid to enter a wetted chamber of the dampener during the discharge stroke. This displaces a flexible bladder, which compresses gas in an air chamber, thus absorbing the shock. During the inlet stroke, liquid pressure decreases as the dampener gas expands, allowing fluid to re-enter the process line.

Since Hydra-Cell multiple-diaphragm model pumps provide smooth, virtually pulse-less linear flow, pulsation dampeners are recommended for F20 and P100 models, but are optional for all other models.



Selection Process

Determine application

- Discharge pulsation <1000 psi or >1000 psi (<69 bar or >69 bar)
- Inlet stabilization:
 - For flooded suction, use “Chargeable.”
 - For suction lift, use “J Style.”

Select dampener size (cu. in. volume)

Based on the Hydra-Cell pump model and application, select the appropriate cubic inch size from the chart at right.

Select dampener model

Use the appropriate dampener size chart on pages 117 to 119 to select the specific model with the desired housing materials, bladder material, and pressure and temperature performance. (Consult factory for special order units with other construction materials and temperature limits.)

Air Control Pump Model	Application			
	Discharge Pulsation		Inlet Stabilization	
	Chargeable <1000 psi <69 bar	Chargeable >1000 psi >69 bar	Chargeable Flooded Suction	J-Style Suction Lift
MT8	4 or 8 cu. in.	8 or 12 cu. in.	N/A	N/A
F20 (P100)	4 cu. in.	8 or 12 cu. in.	10 cu. in.	10 cu. in.
M03 (P200)	4 cu. in.	8 or 12 cu. in.	10 cu. in.	10 cu. in.
D04 (P300)	4 cu. in.	8 or 12 cu. in.	10 cu. in.	10 cu. in.
D10 (P400)	4 cu. in.	8 or 12 cu. in.	10 cu. in.	10 cu. in.
D12	4 cu. in.	N/A	4 cu. in.	10 cu. in.
D15 (P500)	4 cu. in.	8 or 12 cu. in.	10 cu. in.	10 cu. in.
D17	4 cu. in.	8 or 12 cu. in.	10 cu. in.	10 cu. in.
H25 (P600)	36 cu. in.	N/A	36 cu. in.	85 cu. in.
D35	36 cu. in.	12 cu. in.	36 cu. in.	85 cu. in.
D66	36 cu. in.	N/A	370 cu. in.	Consult Factory

Note: These are minimum size recommendations. A larger size can always be used.

Pulsation Dampener Charging Kits

Part Number	Description
110-900	Charging kit to 999 psi (68.9 bar)
110-901	Charging kit from 1000 to 5000 psi (69 to 345 bar)

Bladder Options

Bladder Material	Application Recommendations
Buna-N	Good flex life; use with petroleum, solvents, and oil-based fluids
Neoprene	Good abrasion resistance and flex; use with moderate chemicals
EPDM	Good for extreme cold; good chemical resistance with ketones, caustics
FKM	Good for hot and aggressive fluids; use with aromatics, solvents, acids, and oils
PTFE	Bellows design, excellent flex life; use with highly aggressive fluids

Pulsation Dampeners

4 Cubic Inch Dampeners: Inlet 1/2" (female) Standard Models

Wetted	Bladder	Volume (Inch ³)	Max Pressure		Part Number	
			psi	bar	NPT Ports	BSPT Ports
SST	Buna-N	4	1000	69	110-060	110-060-B
SST	Neoprene	4	1000	69	110-062	110-062-B
SST	EPDM	4	1000	69	110-063	110-063-B
SST	FKM	4	1000	69	110-065	110-065-B
SST	PTFE	4	600	41.4	110-068	110-068-B
Hastelloy C	Buna-N	4	1000	69	110-090	110-090-B
Hastelloy C	Neoprene	4	1000	69	110-092	110-092-B
Hastelloy C	EPDM	4	1000	69	110-093	110-093-B
Hastelloy C	FKM	4	1000	69	110-095	110-095-B
Hastelloy C	PTFE	4	600	41.4	110-098	110-098-B
Polypropylene	Buna-N	4	150	10.3	110-999	110-999-B
Polypropylene	Neoprene	4	150	10.3	110-101	110-101-B
Polypropylene	EPDM	4	150	10.3	110-104	110-104-B
Polypropylene	FKM	4	150	10.3	110-106	110-106-B
Polypropylene	PTFE	4	150	10.3	110-109	110-109-B
PVDF	Buna-N	4	150	10.3	110-020	110-020-B
PVDF	Neoprene	4	150	10.3	110-022	110-022-B
PVDF	EPDM	4	150	10.3	110-023	110-023-B
PVDF	FKM	4	150	10.3	110-026	110-026-B
PVDF	PTFE	4	150	10.3	110-028	110-028-B

10 Cubic Inch Dampeners: Inlet 1/2" (female) Standard Models

Wetted	Bladder	Volume (Inch ³)	Max Pressure		Part Number	
			psi	bar	NPT Ports	BSPT Ports
SST	Buna-N	10	1000	69	110-260	110-260-B
SST	Neoprene	10	1000	69	110-262	110-262-B
SST	EPDM	10	1000	69	110-263	110-263-B
SST	FKM	10	1000	69	110-265	110-265-B
SST	PTFE	10	150	10.3	110-268	110-268-B
Hastelloy C	Buna-N	10	1000	69	110-290	110-290-B
Hastelloy C	Neoprene	10	1000	69	110-292	110-292-B
Hastelloy C	EPDM	10	1000	69	110-293	110-293-B
Hastelloy C	FKM	10	1000	69	110-295	110-295-B
Hastelloy C	PTFE	10	150	10.3	110-298	110-298-B
Polypropylene	Buna-N	10	150	10.3	110-100	110-100-B
Polypropylene	Neoprene	10	150	10.3	110-232	110-232-B
Polypropylene	EPDM	10	150	10.3	110-233	110-233-B
Polypropylene	FKM	10	150	10.3	110-105	110-105-B
Polypropylene	PTFE	10	150	10.3	110-108	110-108-B
PVDF	Buna-N	10	150	10.3	110-220	110-220-B
PVDF	Neoprene	10	150	10.3	110-222	110-222-B
PVDF	EPDM	10	150	10.3	110-223	110-223-B
PVDF	FKM	10	150	10.3	110-225	110-225-B
PVDF	PTFE	10	150	10.3	110-228	110-228-B

Pulsation Dampeners

36 Cubic Inch Dampeners: Inlet 1/2" (female) Standard Models

Wetted	Bladder	Volume (Inch ³)	Max Pressure		Part Number	
			psi	bar	NPT Ports	BSPT Ports
SST	Buna-N	36	1000	69	110-660	110-660-B
SST	Neoprene	36	1000	69	110-662	110-662-B
SST	EPDM	36	1000	69	110-663	110-663-B
SST	FKM	36	1000	69	110-665	110-665-B
SST	PTFE	36	600	41.4	110-668	110-668-B
CS	Buna-N	36	1000	69	110-640	110-640-B
CS	Neoprene	36	1000	69	110-642	110-642-B
CS	EPDM	36	1000	69	110-643	110-643-B
CS	FKM	36	1000	69	110-645	110-645-B
CS	PTFE	36	600	41.4	110-648	110-648-B
Hastelloy C	Buna-N	36	1000	69	110-690	110-690-B
Hastelloy C	Neoprene	36	1000	69	110-692	110-692-B
Hastelloy C	EPDM	36	1000	69	110-693	110-693-B
Hastelloy C	FKM	36	1000	69	110-695	110-695-B
Hastelloy C	PTFE	36	600	41.4	110-698	110-698-B
Polypropylene	Buna-N	36	150	10.3	110-600	110-600-B
Polypropylene	Neoprene	36	150	10.3	110-602	110-602-B
Polypropylene	EPDM	36	150	10.3	110-603	110-603-B
Polypropylene	FKM	36	150	10.3	110-605	110-605-B
Polypropylene	PTFE	36	150	10.3	110-608	110-608-B
PVDF	Buna-N	36	150	10.3	110-620	110-620-B
PVDF	Neoprene	36	150	10.3	110-622	110-622-B
PVDF	EPDM	36	150	10.3	110-623	110-623-B
PVDF	FKM	36	150	10.3	110-625	110-625-B
PVDF	PTFE	36	150	10.3	110-628	110-628-B

85 Cubic Inch Dampeners: Inlet 1" (female) Standard Models

Wetted	Bladder	Volume (Inch ³)	Max Pressure		Part Number	
			psi	bar	NPT Ports	BSPT Ports
SST	Buna-N	85	1000	69	110-760	110-760-B
SST	FKM	85	1000	69	110-765	110-765-B

370 Cubic Inch Dampeners: Inlet 2" (female) Standard Models

Wetted	Bladder	Volume (Inch ³)	Max Pressure		Part Number	
			psi	bar	NPT Ports	BSPT Ports
SST	Buna-N	370	300	20.6	110-910	110-910-B
SST	FKM	370	300	20.6	110-920	110-920-B
CS	Buna-N	370	300	20.6	110-930	110-930-B
CS	FKM	370	300	20.6	119-940	119-940-B

Pulsation Dampeners

8 Cubic Inch Dampeners: Inlet (female) High Pressure Models

Wetted	Bladder	Volume (Inch ³)	Max Pressure		Part Number	
			psi	bar	NPT Ports	BSPT Ports
SST	PTFE	8	4000	275	110-049*	110-049-B*
SST	FKM	8	4000	275	110-050*	110-050-B*
SST	FKM	8	4000	275	110-051	110-051-B
SST	PTFE	8	4000	275	110-052	110-052-B

*2-port, flow-through inlet design

12 Cubic Inch Dampeners: Inlet (female) High Pressure Models

Wetted	Bladder	Volume (Inch ³)	Max Pressure		Part Number	
			psi	bar	NPT Ports	BSPT Ports
SST	Buna-N	12	4000	275	110-370	110-370-B
SST	EPDM	12	4000	275	110-373	110-373-B
SST	FKM	12	4000	275	110-375	110-375-B
SST	PTFE	12	2000	138	110-368	110-368-B
SST	FKM	12	4000	275	110-377	110-377-B
SST	PTFE	12	4000	275	110-378	110-378-B
SST	FKM	12	4000	275	110-379*	110-379-B*
SST	PTFE	12	4000	275	110-380*	110-380-B*

*2-port, flow-through inlet design

10 Cubic Inch Inlet Stabilizers with J-Style Control: Inlet 1/2" (female)

Wetted	Bladder	Volume (Inch ³)	Max Pressure		Part Number	
			psi	bar	NPT Ports	BSPT Ports
CPVC	Buna-N	10	30	2	110-210-J	110-210-J-B
CPVC	Neoprene	10	30	2	110-212-J	110-212-J-B
CPVC	EPDM	10	30	2	110-213-J	110-213-J-B
CPVC	FKM	10	30	2	110-215-J	110-215-J-B
CPVC	PTFE	10	30	2	110-218-J	110-218-J-B

85 Cubic Inch Dampeners with J-Style Control: Inlet 1" (female)

Wetted	Bladder	Volume (Inch ³)	Max Pressure		Part Number	
			psi	bar	NPT Ports	BSPT Ports
PVC	Buna-N	85	30	2	110-710-J	110-710-J-B
PVC	Neoprene	85	30	2	110-712-J	110-712-J-B
PVC	EPDM	85	30	2	110-713-J	110-713-J-B
PVC	FKM	85	30	2	110-715-J	110-715-J-B
PVC	PTFE	85	30	2	110-718-J	110-718-J-B

1155 Cubic Inch Dampeners (5 gallon): Inlet (ANSI flange) 3.0" 150 lbs.

Wetted	Bladder	Volume (Inch ³)	Max Pressure		Part Number
			psi	bar	
CS	Buna	1155	30	2	110-1155-B
CS	FKM	1155	30	2	110-1155-V

Demonstration (Cutaway) Units

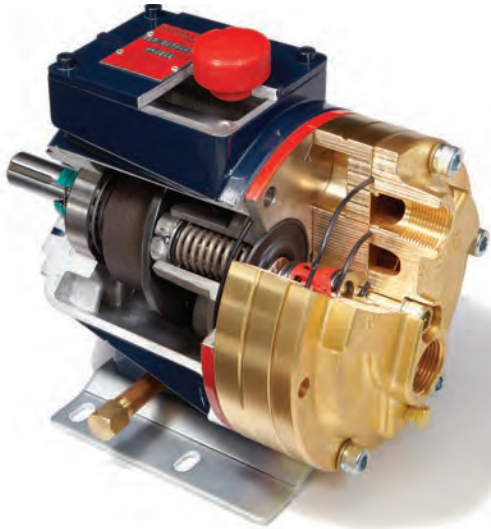

D10 models demonstrate the wobble plate principle of operation.

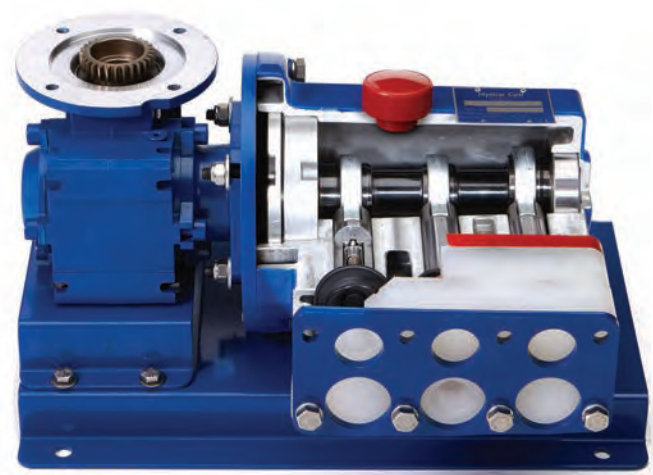

P200 models demonstrate the crank-shaft principle of operation.

Demonstration units of Hydra-Cell D10 and P200 (metering) pumps are available with or without a rolling carry case (furnished with the appropriate sticker). The units are “cut away” to show both the wobble plate (D10) and crank-shaft (P200) operating principles as well as other features including the multiple diaphragm design that provides virtually pulse-free flow, and spring-loaded, horizontal check valves which, combined with the seal-less design, enable Hydra-Cell to handle abrasives and particulates that would damage other types of pumps.

Part Number	Description
CUTAWAY-D10WCASE	D10 Cutaway Demo with Rolling Carry Case
CUTAWAY-D10	D10 Cutaway Demo without Case
CUTAWAY-P200WCASE	P200 Cutaway Demo with Rolling Carry Case
CUTAWAY-P200	P200 Cutaway Demo without Case
CUTAWAY-CASE	Cutaway Demo Rolling Case Only (for D10 or P200)



Cutaway units for demonstration purposes are available with a labeled rolling carry case.

Testing

Wanner Engineering has a fully-equipped testing facility to perform a variety of witnessed and non-witnessed tests with certification for Hydra-Cell pumps.



Part Number	Description	Notes	Hydra-Cell Pump Series		
			F/M/D/H	T & Q	P & MT8
CERT-CONFORMANCE	Certificate of Conformance	Pump Materials	✓	✓	✓
TEST-STDPROD	Standard Production Test	Rated Flow & Rated Pressure	✓	✓	✓
TEST-STDPRODWIT	Witnessed Standard Production Test	Rated Flow & Rated Pressure	✓	✓	✓
TEST-HYDRO	Hydrostatic Test & Certificate	Includes Standard Production Tests	✓		✓
TEST-HYDRO-TQ	Hydrostatic Test & Certificate	Includes Standard Production Tests (High pressure outlet gallery only)		✓	
TEST-HYDROWIT	Witnessed Hydrostatic Test & Certificate	Includes Standard Production Tests	✓		✓
TEST-HYDROWIT-TQ	Witnessed Hydrostatic Test & Certificate	Includes Standard Production Tests (High pressure outlet gallery only)		✓	
TEST-PMI	Positive Material Identification Certificates	Manifold/Valve Plate, T & Q Manifold Only (In-house)	✓	✓	
TEST-PMI-FE	Positive Material Identification Certificates	Metallic Fluid End Parts (In-house)	✓	✓	
TEST-NPSH	Standard NPSHr Test	Not Available for F20 Series	✓		
TEST-NPSH-TQ	Standard NPSHr Test	T & Q Series Pumps		✓	
TEST-NPSHWIT	Witnessed Standard NPSHr Test at Max. rpm (unless specified)		✓		
TEST-STDLIN	API 675 Linearity Test (5-point curve)	Includes Standard Production Tests			✓
TEST-STDLINWIT	Witnessed API 675 Linearity Test (5-point curve)	Includes Standard Production Tests			✓
TEST-STDLINREP	API 675 Repeatability Test (10-point curve)	Includes Standard Production Tests & API 675 Linearity Test			✓
TEST-STDLINREPWIT	Witnessed API 675 Repeatability Test (10-point curve)	Includes Standard Production Tests & API 675 Linearity Test			✓
TEST-STDHYDAPI	API 675 Test Package	Standard Production Tests, Linearity, Repeatability, & Hydrostatic			✓
TEST-STDHYDAPIWIT	Witnessed API 675 Test Package	Standard Production Tests, Linearity, Repeatability, & Hydrostatic			✓
TEST-API675-TQ	API 675 Package	Production, Repeatability, Linearity & Accuracy		✓	
TEST-LIQPENTRANT-TQ	Liquid Penetrant of Manifold	Manifold Only		✓	
TEST-CUSTOM	Contact Factory with Details/Request		✓	✓	✓

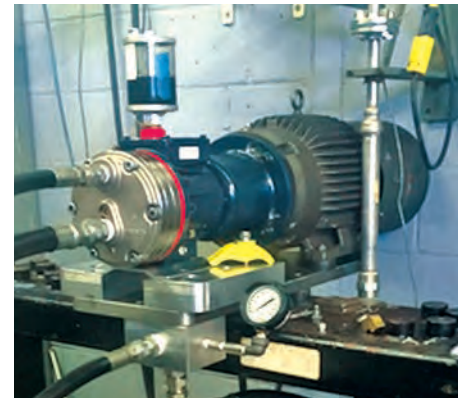
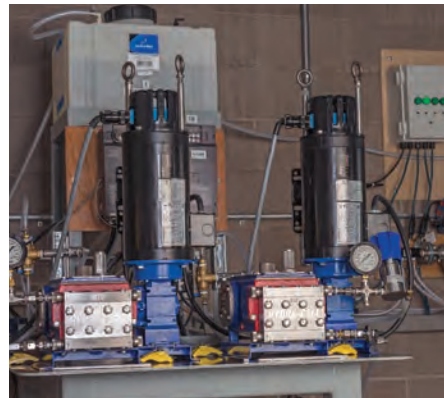

Hydra-Cell® T & Q Series Seal-less Pump Selection

T100 Low Pressure

Page 126



T100 Medium Pressure T100 High Pressure

Page 130



Page 134



Q155 Low Pressure

Page 138



Q155 Medium Pressure

Page 142



T200 Medium Pressure

Page 146



T200 High Pressure

Page 150



Q330 Medium Pressure

Page 154



Q330 High Pressure

Page 158



Hydra-Cell® Flow Capacities and Pressure Ratings

T & Q Series Large Capacity Pumps

Maximum Inlet Pressure for all models: 500 psi (34 bar).
 Maximum Operating Temperature for all models: 180°F (82°C). Consult factory for correct component specification for temperatures above 180°F (82°C) or below 40°F (4°C).

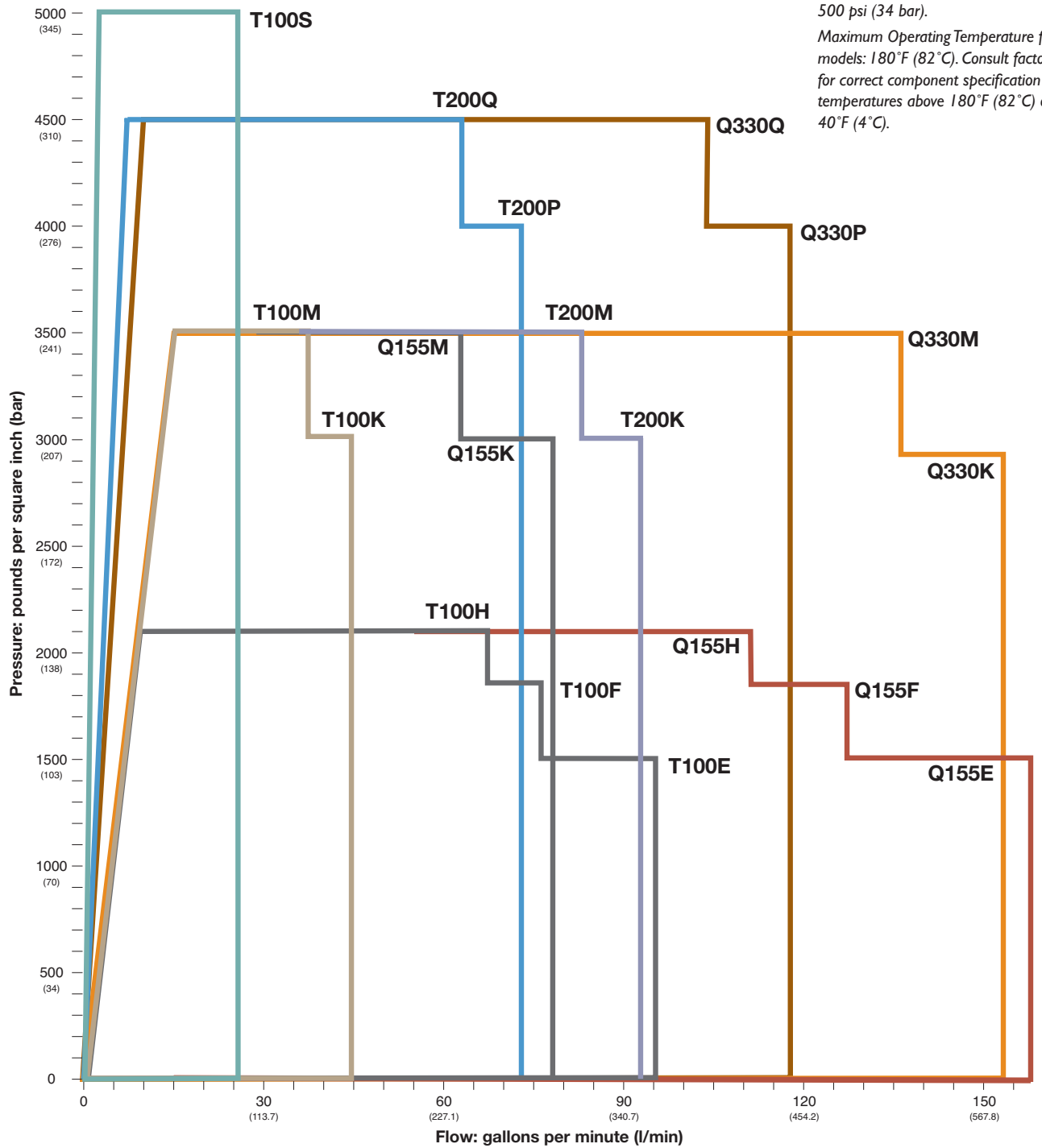

Model	Max. Capacity			Max. Pressure*	Model	Max. Capacity			Max. Pressure*	Model	Max. Capacity			Max. Pressure*
	BPD	gpm	l/min	psi (bar)		BPD	gpm	l/min	psi (bar)		BPD	gpm	l/min	psi (bar)
T100E	3292	96.0	366.1	1500 (103)	Q155E	5383	157	595	1500 (103)	T200P	2469	72	272	4000 (276)
T100F	2623	76.5	289.6	1850 (128)	Q155F	4354	127	490	1850 (128)	T200Q	2160	63	238	4500 (310)
T100H	2332	68.0	257.8	2100 (145)	Q155H	3806	111	421	2100 (145)	Q330K	5247	153	579	3000 (207)
T100K	1543	45.0	170.4	3000 (207)	Q155K	2674	78	295	3000 (207)	Q330M	4664	136	514	3500 (241)
T100M	1302	38.0	143.8	3500 (241)	Q155M	2160	63	238	3500 (241)	Q330P	4011	117	442	4000 (276)
T100S	891	26.0	98.4	5000 (345)	T200K	3189	93	352	3000 (207)	Q330Q	3566	104	393	4500 (310)
					T200M	2846	83	314	3500 (241)					

*Maximum Discharge Pressure

Hydra-Cell® T & Q Series Design Advantages

An Economical and Environmental Choice

Hydra-Cell is a positive displacement, multiple-diaphragm pump featuring a seal-less design that separates the power end from the process fluid end. This provides full containment of the pumping chamber.

As a result, there are no VOC emissions when operating a Hydra-Cell pump and no need for expensive “vapor-less” options to control VOC emissions as there are with other pump designs.

In addition, there are no packing or dynamic seals that pose environmental issues from leakage, which contributes to costly packing or seal wear, maintenance, and downtime.

Hydra-Cell T & Q Series pumps are available with a wide range of manifold, valve, and diaphragm materials to meet different process applications and safeguard the pump if hydrogen sulfide (H₂S) is present.

Compact direct drive skid designs offer a smaller installation footprint. T100 and Q155 models also feature a double-ended shaft for greater versatility. Rugged construction helps ensure long life with minimal maintenance.

Ideal for a Variety of Applications

- Amine Injection
- Boiler Feed Condensate
- Brine Transfer
- Chemical Metering
- Crude Oil Transfer
- Gas Dehydration (Drying)
- Jet Lift
- LACT Unit Transfer
- Methanol & Glycol Injection
- Natural Gas Liquids
- Produced Water
- Saltwater Disposal (SWD)
- Waterflooding

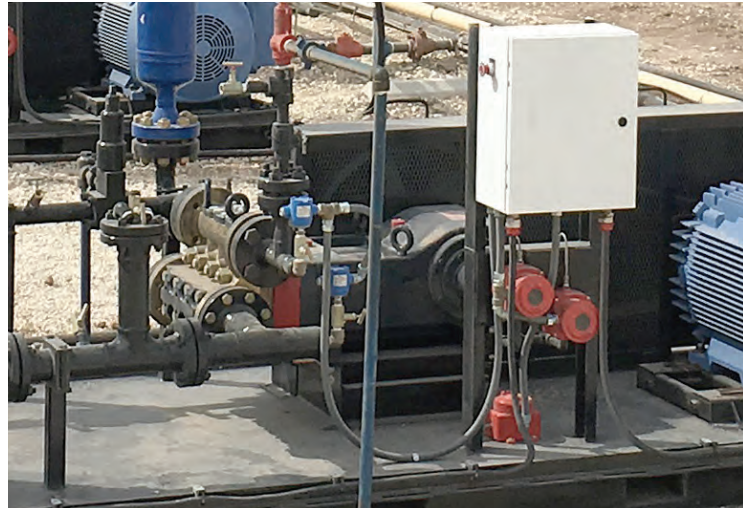

Designed for higher pressures, T and Q Series pumps provide reliable, low-maintenance service in a variety of field production and transport applications (T100 shown).



T and Q Series pumps feature the Hydra-Cell seal-less design, eliminating clean-up costs from leaking seals or packing and protecting operators from dangerous fluids such as those containing hydrogen sulfide (Q155 shown).

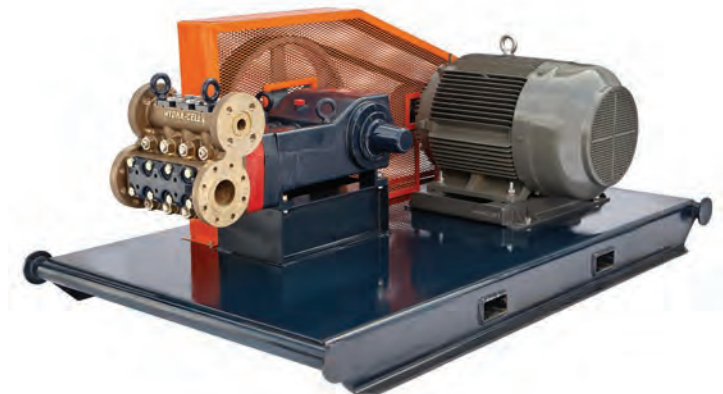

The Hydra-Cell High Pressure model was a finalist in the Pumps & Systems “Product Innovation” awards, and the T100 Series earned a “Spotlight on New Technology” from the Offshore Technology Conference.

Hydra-Cell® T & Q Series Design Advantages

Exclusive Seal-less Diaphragm Design

- Seal-less design means no packing to leak, replace, or adjust. There are less downtime, less environmental containment costs, and less annual maintenance compared to conventional plunger pumps.
- No mechanical or dynamic seals to leak, fail, or replace.
- Can run dry indefinitely; the pump does not use the process fluid for lubrication.
- Patented diaphragm position control technology enables operation and protects the pump in case of a closed inlet due to abnormal or adverse conditions, or operational error.
- Can pump the full spectrum of low-to-high-viscosity fluids, including water-thin fluids. The required flow is delivered due to very low slip rates.
- Hydraulically balanced diaphragm design for long life.
- Handles sand or other solids up to 800 microns in size; no fine filtration is required.
- Accurate control of flow rate by varying pump speed over a wide range of discharge pressures and fluid viscosities.
- Higher volumetric efficiency than centrifugal pumps and gear pumps when pumping low-viscosity fluids.
- Lower energy costs than centrifugal pumps and other pump technologies.

**Available
to Meet
API 674!**

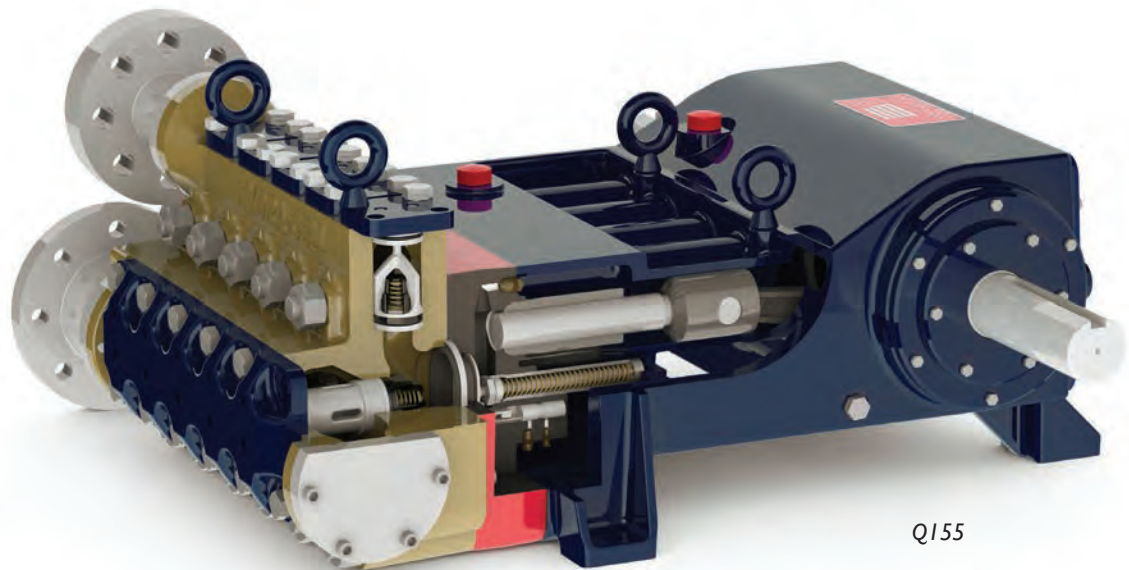
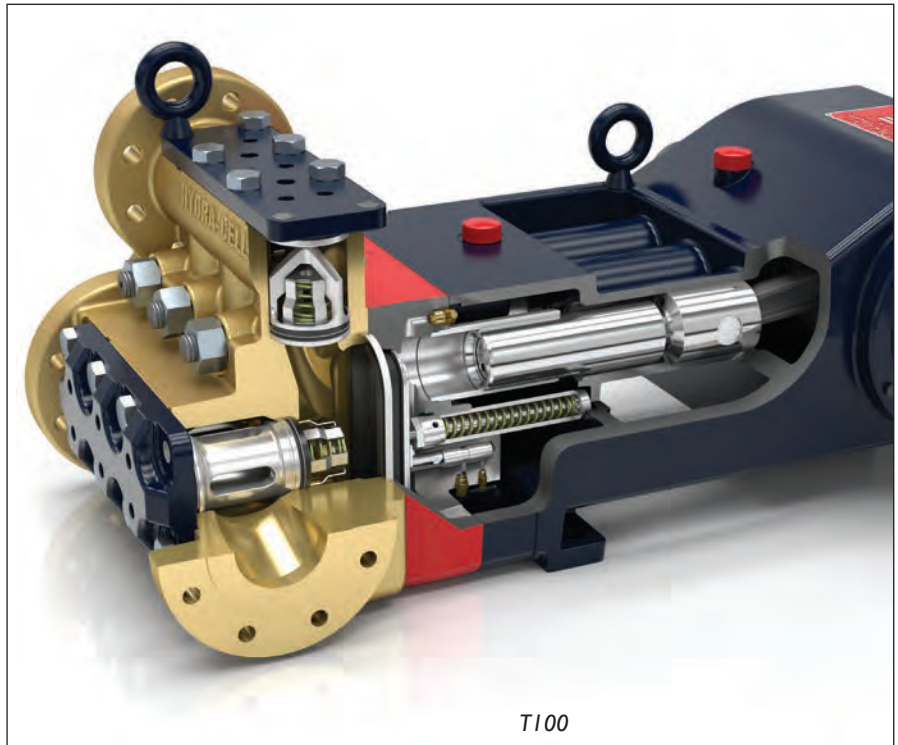

T100 Series Low Pressure Performance

Capacities

Model	Max. Input rpm	Plunger Dia.		Max. Flow Capacities			Max. Pressure Ratings Discharge		Max. Pressure Ratings Inlet	
		Inches	mm	gpm	l/min	BPD	psi	bar	psi	bar
T100E	450	2.500	64	96.0	366.1	3292	1500	103	500	34
T100F	450	2.250	57	76.5	289.6	2623	1850	128	500	34
T100H	450	2.125	54	68.0	257.8	2332	2100	145	500	34

Consult factory when operating below 45 rpm.

Maximum Flow at Designated Pressure

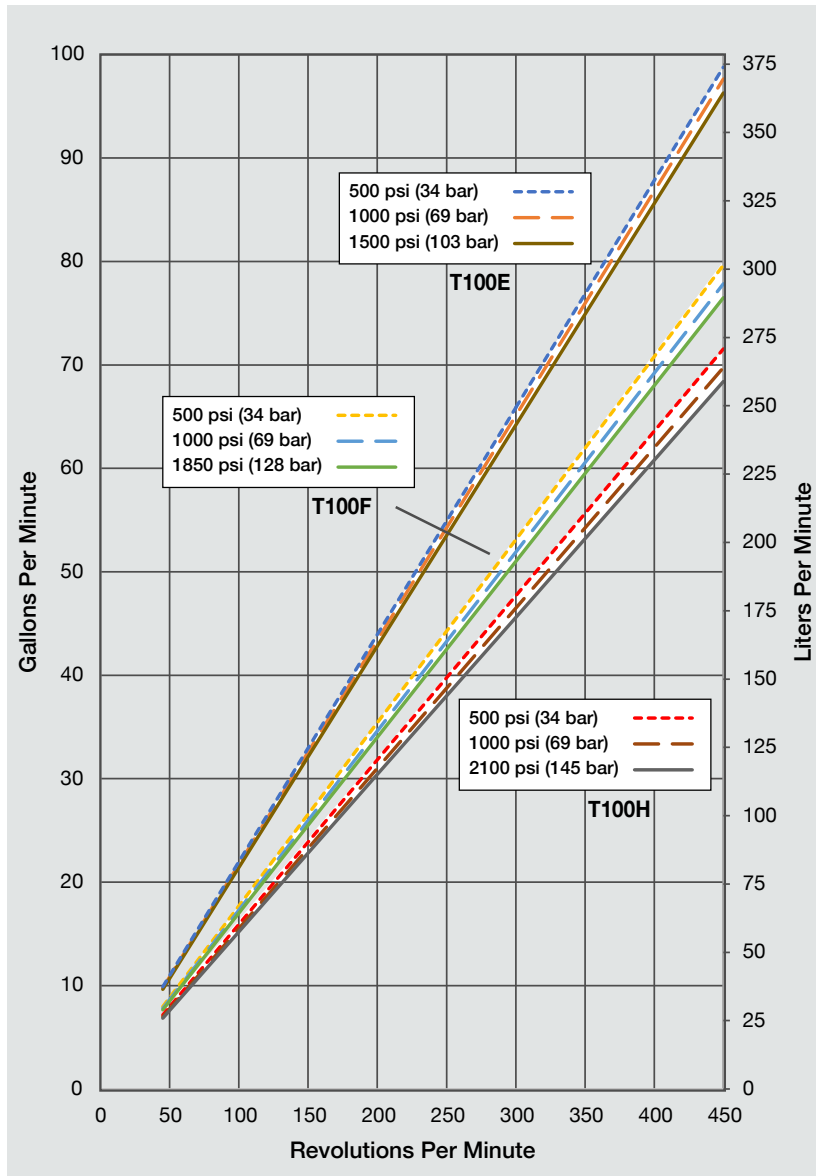

T100 low pressure model shown with Nickel Aluminum Bronze (NAB) manifold. (Also available with Stainless Steel manifold.)

Net Positive Suction Head (NPSHr)

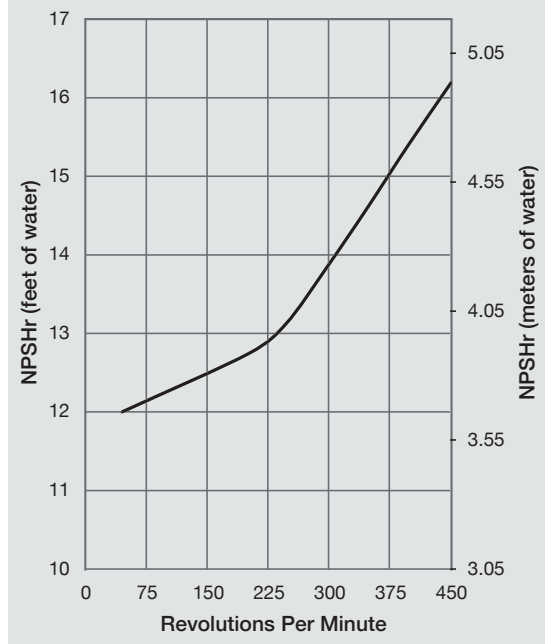

T100 Series Low Pressure Specifications

Flow Capacities

Model	Pressure psi (bar)	rpm	gpm	l/min	BPD
T100E	1500 (103)	450	96.0	366.1	3292
T100F	1850 (128)	450	76.5	289.6	2623
T100H	2100 (145)	450	68.0	257.8	2332

Delivery

	Pressure psi (bar)	gal/rev	liters/rev
T100E	500 (34)	0.220	0.831
	1000 (69)	0.217	0.821
	1500 (103)	0.214	0.809
T100F	500 (34)	0.177	0.669
	1000 (69)	0.173	0.655
	1850 (128)	0.170	0.644
T100H	500 (34)	0.159	0.601
	1000 (69)	0.155	0.587
	2100 (145)	0.152	0.575

rpm

Maximum:	450
Minimum:	45 (Consult factory for speeds less than 45 rpm.)

Maximum Discharge Pressure

Metallic Heads:	T100E	1500 psi (103 bar)
	T100F	1850 psi (128 bar)
	T100H	2100 psi (145 bar)

Maximum Inlet Pressure

500 psi (34 bar)

Operating Temperature

Maximum:	180° F (82.2° C)
Minimum:	40° F (4.4° C)

Consult factory for temperatures outside this range.

Maximum Solids Size

800 microns

Input Shaft

Left or Right Side

Inlet Ports

3-1/2 inch Class 300 RF ANSI Flange

Discharge Ports

2 inch Class 900 RF ANSI Flange

Plunger Stroke Length

3-1/2 inch (88.9 mm)

Shaft Diameter

3 inch (76.2 mm)

Shaft Rotation

Uni-directional (See rotation arrow.)

Oil Capacity

18 US quarts (17 liters) - blank back cover
20.5 US quarts (19.4 liters) - oil level back cover

See How to Order on page 129 for oil selection;
see page 100 for oil specification.

Weight

Metallic Heads: 1100 lbs. (499 kg)

Fluid End Materials

Diaphragm Follower Screw:	316 Stainless Steel
Outlet Valve Retainer:	316 Stainless Steel
Plug-Outlet Valve Port:	316 Stainless Steel
Inlet Valve Retainer:	316 Stainless Steel

See How to Order on page 129 for customer-specified fluid end materials choices.

Power End Materials

Crankshaft:	Forged Q&T Alloy Steel
Connecting Rods:	Ductile Iron
Crossheads:	12L14 Steel
Crankcase:	Ductile Iron
Bearings:	Spherical Roller/Journal (main)
	Steel Backed Babbit (crankpin)
	Bronze (wristpin)

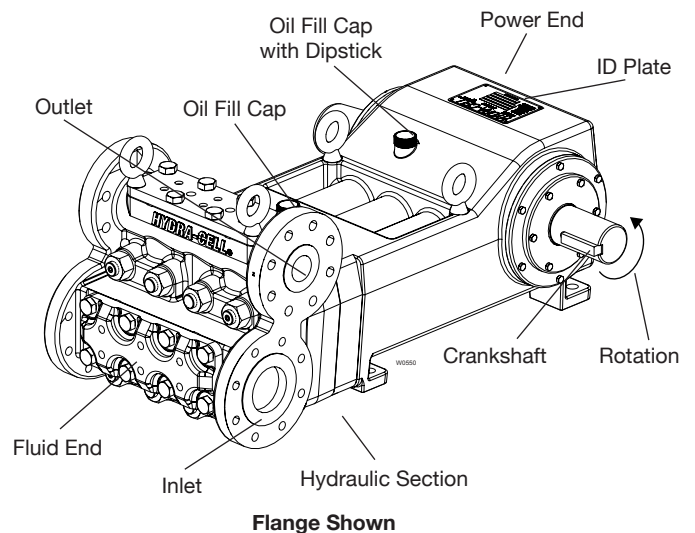

Calculating Required Horsepower (kW)*

$$\frac{\text{gpm} \times \text{psi}}{1,460} = \text{electric motor hp}^*$$

$$\frac{\text{lpm} \times \text{bar}}{511} = \text{electric motor kW}^*$$

* hp (kW) is required application power.

Attention!

When sizing motors with variable speed drives (VFD): It is very important to select a motor and a VFD rated for constant torque inverter duty service and that the motor is rated to meet the torque requirements of the pump throughout desired speed range.

T100 Series Low Pressure Drawings

Flanged Version inches (mm)

Bottom View

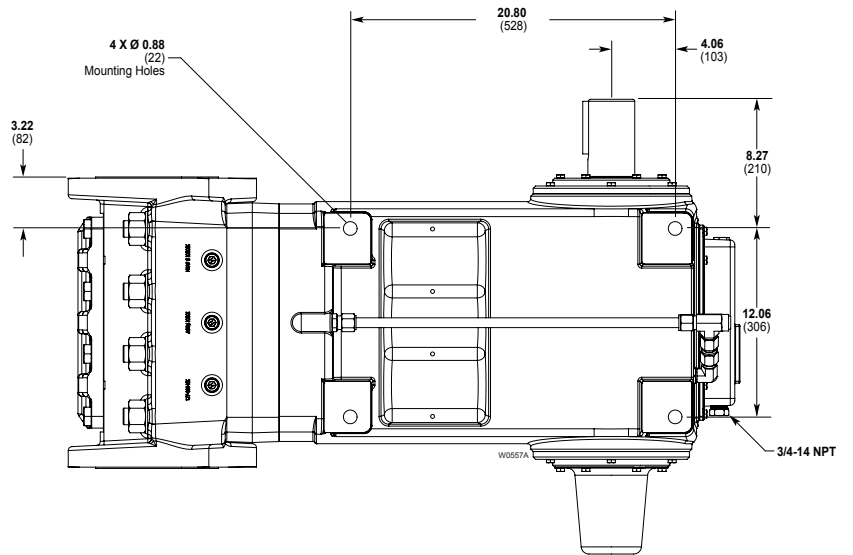

Front View

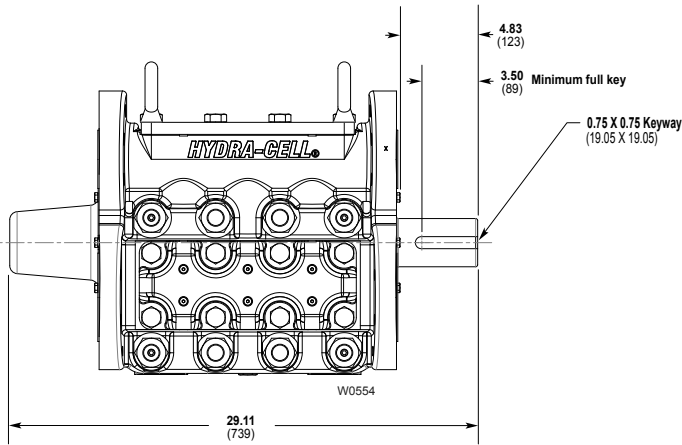

Side View

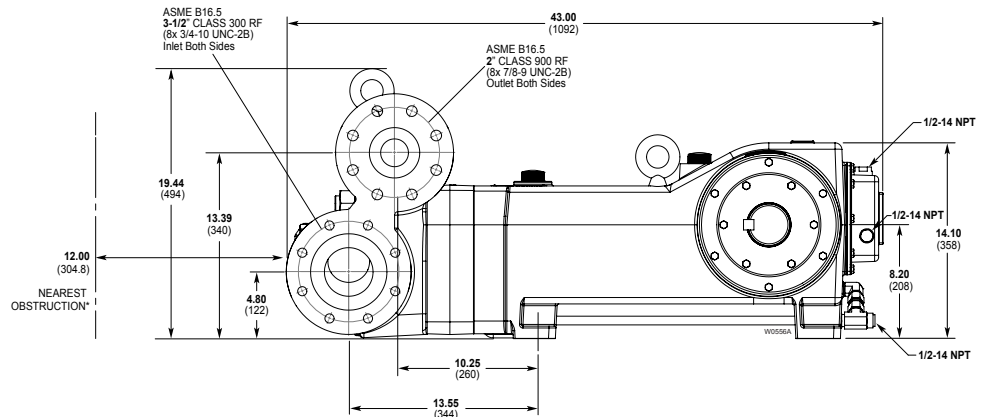

*Contact factory for obstruction distances closer than 12 inches (304.8 mm).

Note: Dimensions are for reference only. Contact factory for certified drawings.

T100 Series Low Pressure How to Order

Ordering Information

1	2	3	4	5	6	7	8	9	10	11	12	13	14
T	1	0	0		R								

A complete T100 Series Low Pressure Model Number contains 14 digits including 9 customer-specified design and materials options, for example: T100ERDGHFESAO.

Low Pressure

Digit	Order Code	Description
1-4	T100	Pump Configuration Shaft-driven
5	E	Performance Max. 96.0 gpm (366.1 l/min) 3292 BPD @ 1500 psi (103 bar)
	F	Max. 76.5 gpm (289.6 l/min) 2623 BPD @ 1850 psi (128 bar)
	H	Max. 68.0 gpm (257.8 l/min) 2332 BPD @ 2100 psi (145 bar)
6	R	Pump Head Version ANSI Flanged Ports (RF on Inlet / RF on Discharge)
7	D	Pump Head Material Nickel Aluminum Bronze (NAB)
	G	Duplex Alloy 2205 Stainless Steel
	S	316L Stainless Steel CF3M
	T	Hastelloy CX2M
8	A	Diaphragm & O-ring Material Aflas
	E	EPDM (requires EPDM-compatible oil - Digit 13 oil code D)
	G	FKM
	T	Buna-N
9	D	Valve Seat Material Tungsten Carbide*
	H	17-4 Stainless Steel
	N	Nitronic 50
	T	Hastelloy C
10	D	Valve Material Tungsten Carbide*
	F	17-4 Stainless Steel
	N	Nitronic 50
	T	Hastelloy C
11	E	Valve Springs Elgiloy
	T	Hastelloy C

Digit	Order Code	Description
12	S	Valve Spring Retainers 316 SST
	T	Hastelloy C
13	A	Hydra-Oil 10W30 standard-duty oil
	B	40-wt. oil
	D	EPDM-compatible oil
	E	Food-contact oil
	H	15W50 high-temp severe-duty synthetic oil
14	C	Oil Level Monitor Cover Float switch, normally closed (recommended)
	O	Float switch, normally open
	S	Float switch, Class I, Div. 1, Groups A, B, C, D, normally closed
	T	Float switch, Class I, Div. 1, Groups A, B, C, D, normally open
	W	Float switch, ATEX/IECEx, 4-20 mA analog output (qualification required)
	X	Float switch, ATEX/IECEx, 4-20 mA discrete output (qualification required)
	Y	No switch, flat back cover

Note: The Oil Level Monitor Cover is an assembly that replaces the previous back cover on T100 Series pumps. It contains a float switch assembly that can trigger an alarm or shutdown when pre-defined levels of high or low oil are reached. It may also be ordered without a float switch cover.

*Tungsten Carbide valve seat and disc are a matched set and must be purchased together.

T100 Series Medium Pressure Performance

Capacities

Model	Max. Input rpm	Plunger Dia.		Max. Flow Capacities			Max. Pressure Ratings Discharge		Max. Pressure Ratings Inlet	
		Inches	mm	gpm	l/min	BPD	psi	bar	psi	bar
T100K	450	1.750	44	45.0	170.4	1543	3000	207	500	34
T100M	450	1.625	41	38.0	143.8	1302	3500	241	500	34

Consult factory when operating below 45 rpm.

Maximum Flow at Designated Pressure

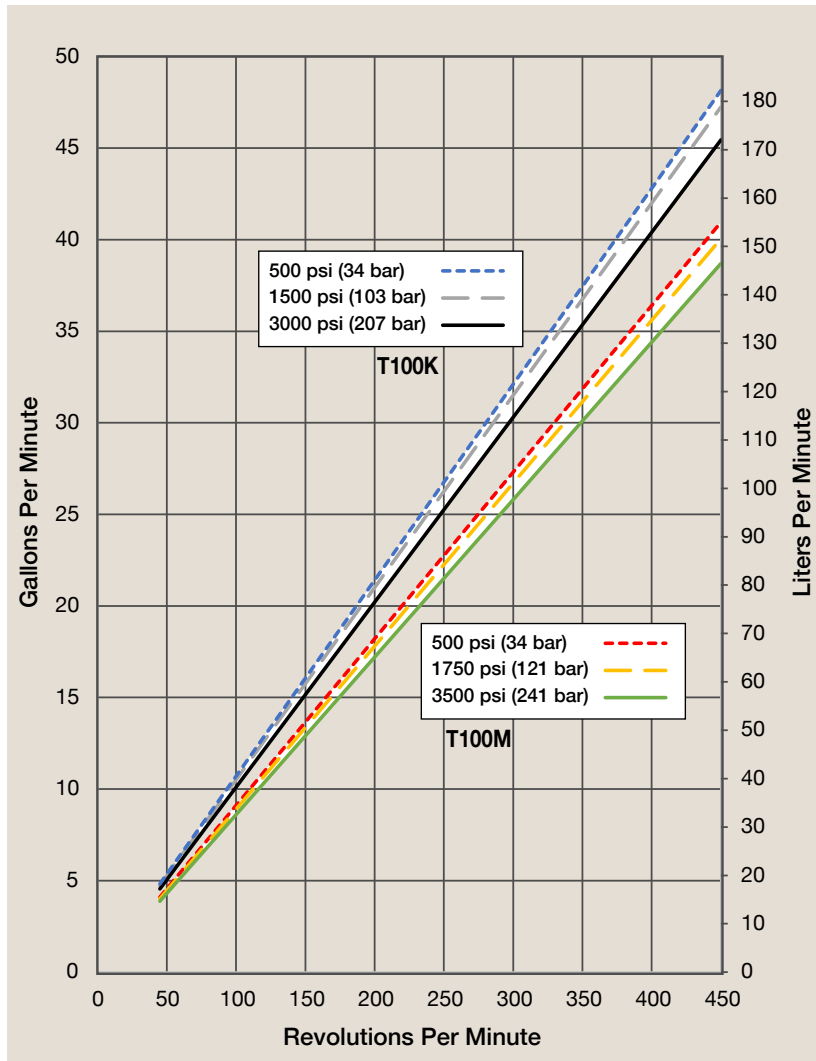

T100 medium pressure model shown with Stainless Steel manifold. (Also available with Nickel Aluminum Bronze/NAB manifold.)

Net Positive Suction Head (NPSHr)

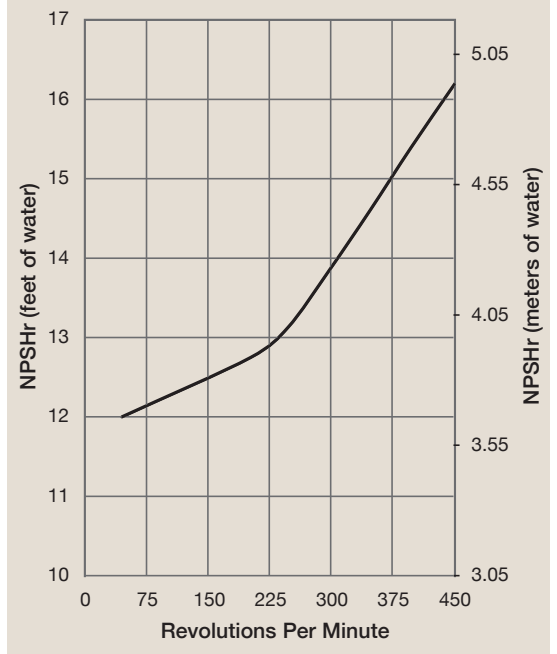

T100 Series Medium Pressure Specifications

Flow Capacities

Model	Pressure psi (bar)	rpm	gpm	l/min	BPD
T100K	3000 (207)	450	45.0	170.4	1543
T100M	3500 (241)	450	38.0	143.8	1302

Delivery

	Pressure psi (bar)	gal/rev	liters/rev
T100K	500 (34)	0.107	0.406
	1500 (103)	0.105	0.397
	3000 (207)	0.101	0.384
T100M	500 (34)	0.091	0.345
	1750 (121)	0.089	0.338
	3500 (241)	0.086	0.327

rpm

Maximum:	450
Minimum:	45 (Consult factory for speeds less than 45 rpm.)

Maximum Discharge Pressure

Metallic Heads:	T100K	3000 psi (207 bar)
	T100M	3500 psi (241 bar)

Maximum Inlet Pressure

500 psi (34 bar)

Operating Temperature

Maximum:	180° F (82.2° C)
Minimum:	40° F (4.4° C)

Consult factory for temperatures outside this range.

Maximum Solids Size

800 microns

Input Shaft

Left or Right Side

Inlet Ports

3-1/2 inch Class 300 RF ANSI Flange or
2-1/2 inch NPT

Discharge Ports

1-1/2 inch Class 2500 RTJ ANSI Flange or
1-1/2 inch NPT

Plunger Stroke Length

3-1/2 inch (88.9 mm)

Shaft Diameter

3 inch (76.2 mm)

Shaft Rotation

Uni-directional (See rotation arrow.)

Oil Capacity

18 US quarts (17 liters) - blank back cover
20.5 US quarts (19.4 liters) - oil level back cover

See How to Order on page 133 for oil selection;
see page 100 for oil specification.

Weight

Metallic Heads: 1100 lbs. (499 kg)

Fluid End Materials

Diaphragm Follower Screw:	316 Stainless Steel
Outlet Valve Retainer:	316 Stainless Steel
Plug-Outlet Valve Port:	316 Stainless Steel
Inlet Valve Retainer:	316 Stainless Steel
See How to Order on page 133 for customer-specified fluid end materials choices.	

Power End Materials

Crankshaft:	Forged Q&T Alloy Steel
Connecting Rods:	Ductile Iron
Crossheads:	12L14 Steel
Crankcase:	Ductile Iron
Bearings:	Spherical Roller/Journal (main)
	Steel Backed Babbitt (crankpin)
	Bronze (wristpin)

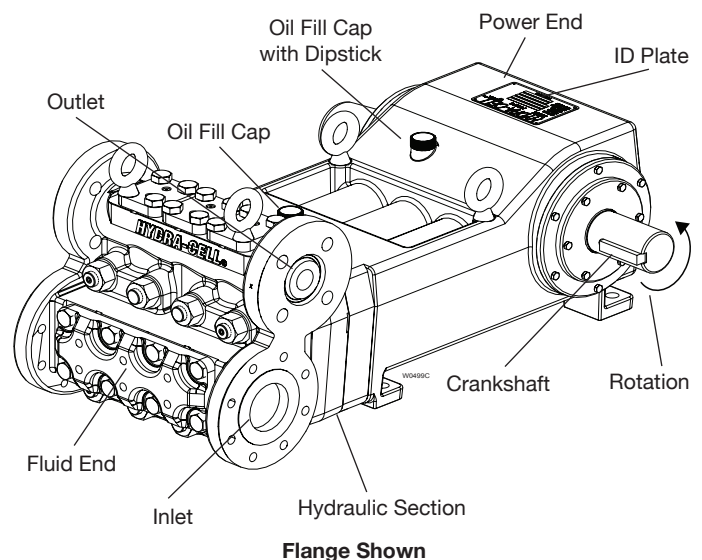

Calculating Required Horsepower (kW)*

$$\frac{\text{gpm} \times \text{psi}}{1,460} = \text{electric motor hp}^*$$

$$\frac{\text{lpm} \times \text{bar}}{511} = \text{electric motor kW}^*$$

* hp (kW) is required application power.

Attention!

When sizing motors with variable speed drives (VFD): It is very important to select a motor and a VFD rated for constant torque inverter duty service and that the motor is rated to meet the torque requirements of the pump throughout desired speed range.

TI00 Series Medium Pressure Drawings

Threaded Version Inches (mm)

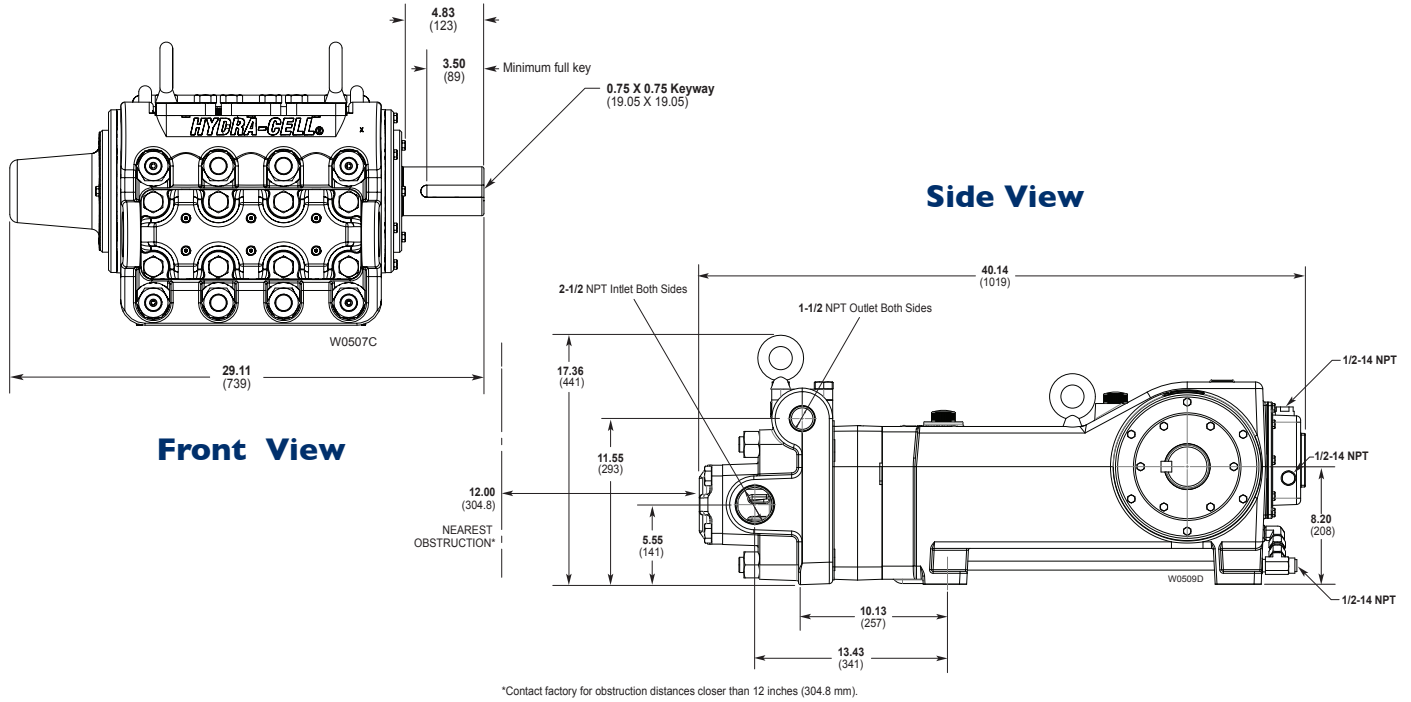

Flanged Version Inches (mm)

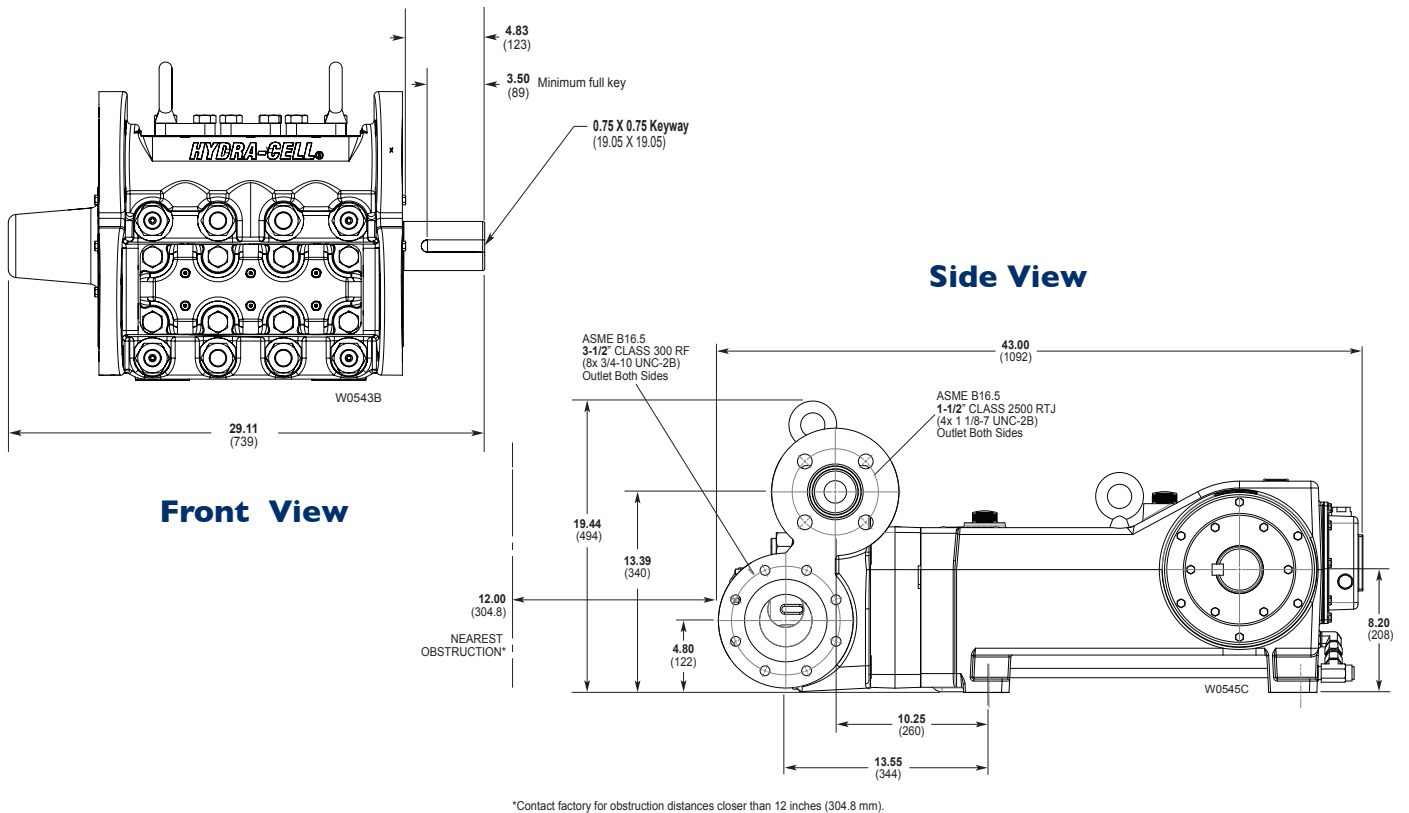

Note: Dimensions are for reference only. Contact factory for certified drawings.

T100 Series Medium Pressure **How to Order**

Ordering Information

1	2	3	4	5	6	7	8	9	10	11	12	13	14
T	1	0	0										

A complete T100 Series Medium Pressure Model Number contains 14 digits including 10 customer-specified design and materials options, for example: T100KADGDDEPAC.

Medium Pressure

Digit	Order Code	Description
1-4	T100	Pump Configuration Shaft-driven
5	K	Performance Max. 45.0 gpm (170.4 l/min) 1543 BPD @ 3000 psi (207 bar)
	M	Max. 38.0 gpm (143.8 l/min) 1302 BPD @ 3500 psi (241 bar)
6	A	Pump Head Version NPT Ports (for NAB only)
	R	ANSI Flanged Ports (RF on Inlet / RTJ on Discharge)
7	D	Pump Head Material Nickel Aluminum Bronze (NAB)
	G	Duplex Alloy 2205 Stainless Steel
	S	316L Stainless Steel CF3M
	T	Hastelloy CX2M
8	A	Diaphragm & O-ring Material Aflas
	E	EPDM (requires EPDM-compatible oil - Digit 13 oil code D)
	G	FKM
	T	Buna-N
9	D	Valve Seat Material Tungsten Carbide*
	H	17-4 Stainless Steel
	N	Nitronic 50
	T	Hastelloy C
10	D	Valve Material Tungsten Carbide*
	F	17-4 Stainless Steel
	N	Nitronic 50
	T	Hastelloy C
11	E	Valve Springs Elgiloy
	T	Hastelloy C

*Tungsten Carbide valve seat and disc are a matched set and must be purchased together.

Digit	Order Code	Description
12	M	Valve Spring Retainers PVDF
	P	Polypropylene
	S	316 SST
	T	Hastelloy C
13	A	Hydra-Oil 10W30 standard-duty oil
	B	40-wt. oil
	D	EPDM-compatible oil
	E	Food-contact oil
	H	15W50 high-temp severe-duty synthetic oil
14	C	Oil Level Monitor Cover Float switch, normally closed (recommended)
	O	Float switch, normally open
	S	Float switch, Class I, Div. 1, Groups A, B, C, D, normally closed
	T	Float switch, Class I, Div. 1, Groups A, B, C, D, normally open
	W	Float switch, ATEX/IECEx, 4-20 mA analog output (qualification required)
	X	Float switch, ATEX/IECEx, 4-20 mA discrete output (qualification required)
	Y	No switch, flat back cover

Note: The Oil Level Monitor Cover is an assembly that replaces the previous back cover on T100 Series pumps. It contains a float switch assembly that can trigger an alarm or shutdown when pre-defined levels of high or low oil are reached. It may also be ordered without a float switch cover.

T100 Series High Pressure Performance

Capacities

Model	Max. Input rpm	Plunger Dia.		Max. Flow Capacities			Max. Pressure Ratings Discharge		Max. Pressure Ratings Inlet	
		Inches	mm	gpm	l/min	BPD	psi	bar	psi	bar
T100S	450	1.375	35	26.0	98.4	891	5000	345	500	34

Consult factory when operating below 45 rpm.

Maximum Flow at Designated Pressure

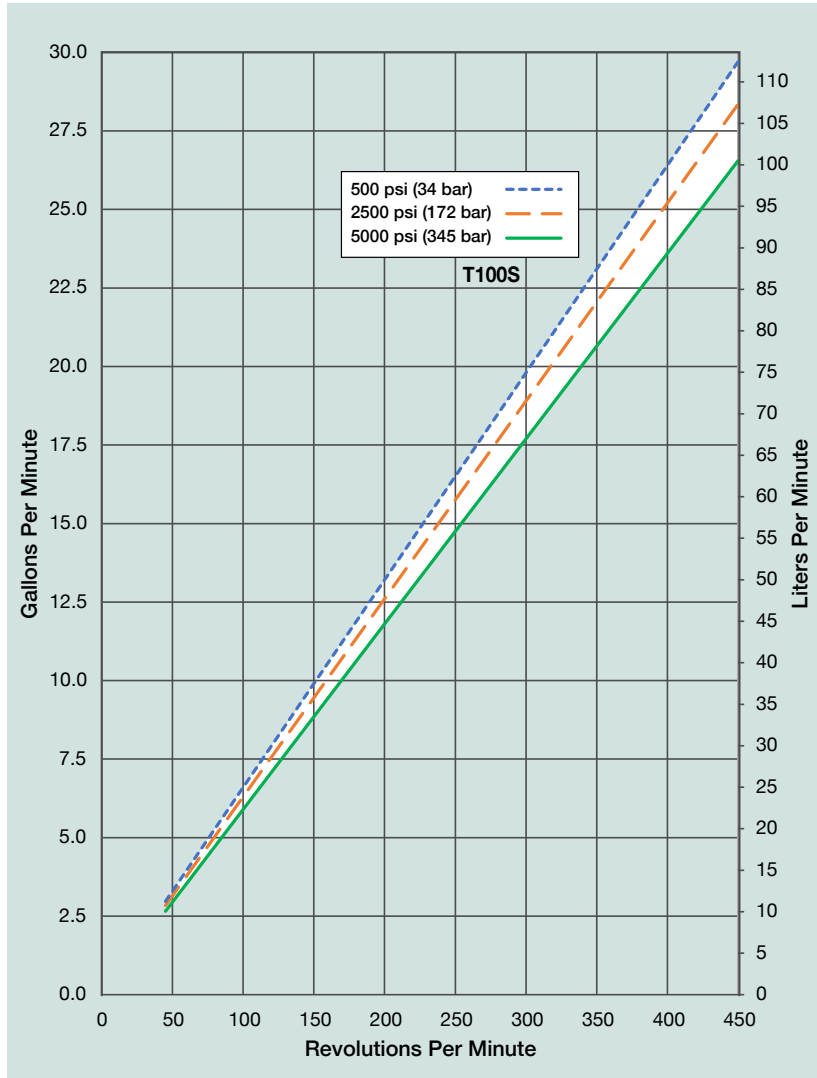

T100 high pressure model shown with Nickel Aluminum Bronze (NAB) manifold. (Also available with Stainless Steel manifold.)

Net Positive Suction Head (NPSHr)

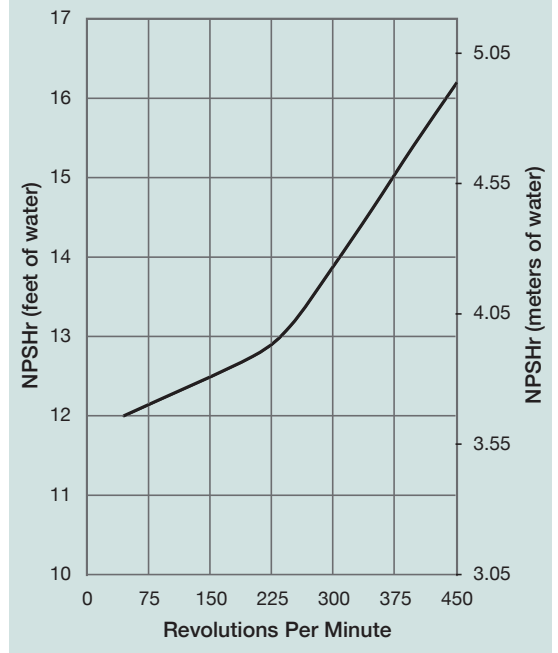

T100 Series High Pressure Specifications

Flow Capacities

Model	Pressure psi (bar)	rpm	gpm	l/min	BPD
T100S	5000 (345)	450	26.0	98.4	891

Delivery

	Pressure psi (bar)	gal/rev	liters/rev
T100S	500 (34)	0.066	0.249
	2500 (172)	0.063	0.237
	5000 (345)	0.059	0.222

rpm

Maximum:	450
Minimum:	45 (Consult factory for speeds less than 45 rpm.)

Maximum Discharge Pressure

Metallic Heads:	5000 psi (345 bar)
-----------------	--------------------

Maximum Inlet Pressure

	500 psi (34 bar)
--	------------------

Operating Temperature

Maximum:	180 °F (82.2 °C)
Minimum:	40 °F (4.4 °C)

Consult factory for temperatures outside this range.

Maximum Solids Size

	800 microns
--	-------------

Input Shaft

	Left or Right Side
--	--------------------

Inlet Ports

	2 inch Class 300 FF ANSI Flange
--	---------------------------------

Discharge Ports

	1-1/4 inch Class 2500 RTJ ANSI Flange
--	---------------------------------------

Plunger Stroke Length

	3-1/2 inch (88.9 mm)
--	----------------------

Shaft Diameter

	3 inch (76.2 mm)
--	------------------

Shaft Rotation

	Uni-directional (See rotation arrow.)
--	---------------------------------------

Oil Capacity

	18 US quarts (17 liters) - blank back cover
	20.5 US quarts (19.4 liters) - oil level back cover
	See How to Order on page 137 for oil selection;
	see page 100 for oil specification.

Weight

Metallic Heads:	1100 lbs. (499 kg)
-----------------	--------------------

Fluid End Materials

Diaphragm Follower Screw:	316 Stainless Steel
Outlet Valve Retainer:	316 Stainless Steel
Plug-Outlet Valve Port:	316 Stainless Steel
Inlet Valve Retainer:	316 Stainless Steel
See How to Order on page 137 for customer-specified fluid end materials choices.	

Power End Materials

Crankshaft:	Forged Q&T Alloy Steel
Connecting Rods:	Ductile Iron
Crossheads:	12L14 Steel
Crankcase:	Ductile Iron
Bearings:	Spherical Roller/Journal (main)
	Steel Backed Babbit (crankpin)
	Bronze (wristpin)

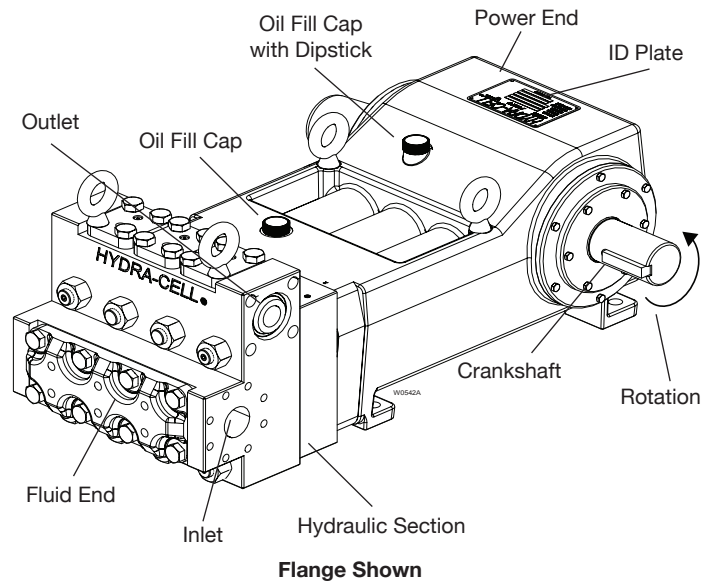

Calculating Required Horsepower (kW)*

$$\frac{\text{gpm} \times \text{psi}}{1,460} = \text{electric motor hp}^*$$

$$\frac{\text{lpm} \times \text{bar}}{511} = \text{electric motor kW}^*$$

* hp (kW) is required application power.

Attention!

When sizing motors with variable speed drives (VFD): It is very important to select a motor and a VFD rated for constant torque inverter duty service and that the motor is rated to meet the torque requirements of the pump throughout desired speed range.

T100 Series High Pressure Drawings

Threaded Version Inches (mm)

Front View

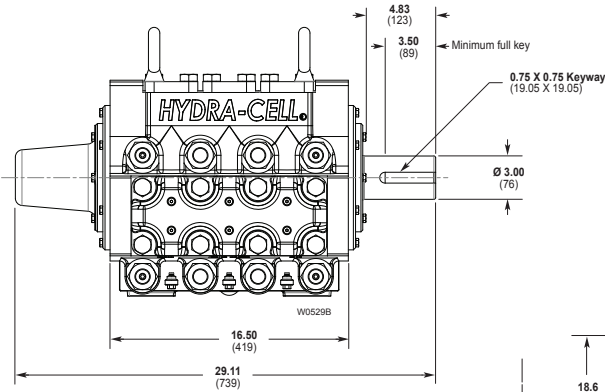

Side View

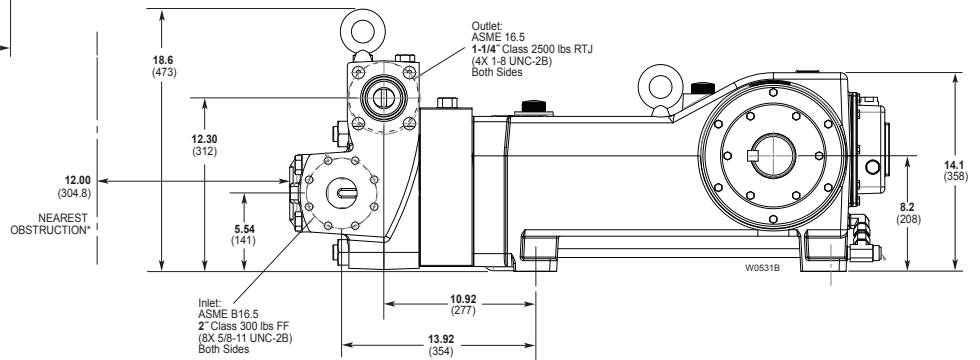

*Contact factory for obstruction distances closer than 12 inches (304.8 mm).

Top View

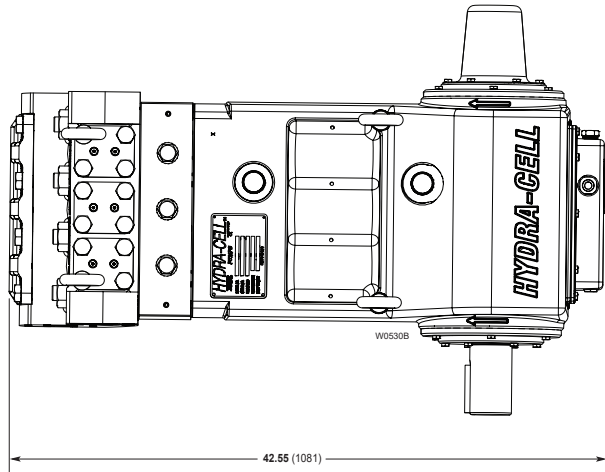

Bottom View

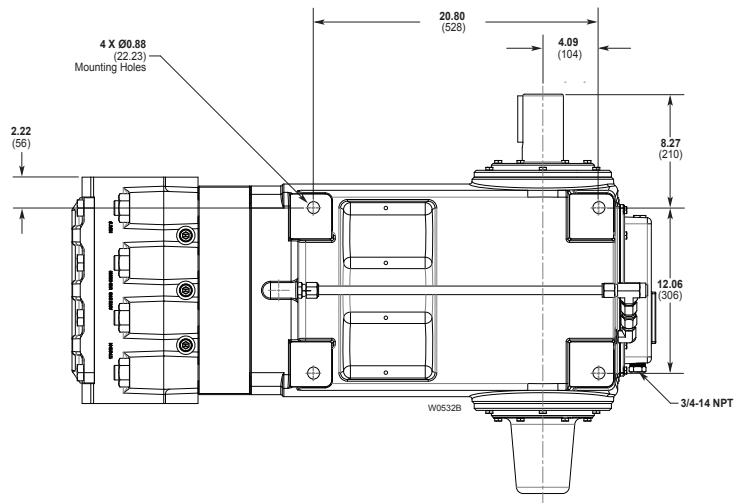

Note: Dimensions are for reference only. Contact factory for certified drawings.

T100 Series High Pressure **How to Order**

Ordering Information

1	2	3	4	5	6	7	8	9	10	11	12	13	14
T	1	0	0	S	R								

A complete T100 Series High Pressure Model Number contains 14 digits including 8 customer-specified design and materials options, for example: T100SRDTHFEPAX.

High Pressure

Digit	Order Code	Description
1-4	T100	Pump Configuration Shaft-driven
5	S	Performance Max. 26.0 gpm (98.4 l/min) 891 BPD @ 5000 psi (345 bar)
6	R	Pump Head Version ANSI Flanged Ports (RF on Inlet / RTJ on Discharge)
7	D S	Pump Head Material Nickel Aluminum Bronze (NAB) 316L Stainless Steel
8	A E G T	Diaphragm & O-ring Material Aflas EPDM (requires EPDM-compatible oil - Digit 13 oil code D) FKM Buna-N
9	D H N T	Valve Seat Material Tungsten Carbide* 17-4 Stainless Steel Nitronic 50 Hastelloy C
10	D F N T	Valve Material Tungsten Carbide* 17-4 Stainless Steel Nitronic 50 Hastelloy C
11	E T	Valve Springs Elgiloy Hastelloy C

*Tungsten Carbide valve seat and disc are a matched set and must be purchased together.

Digit	Order Code	Description
12	M P S T	Valve Spring Retainers PVDF Polypropylene 316 SST Hastelloy C
13	A B D E H	Hydra-Oil 10W30 standard-duty oil 40-wt. oil EPDM-compatible oil Food-contact oil 15W50 high-temp severe-duty synthetic oil
14	C O S T W X Y	Oil Level Monitor Cover Float switch, normally closed (recommended) Float switch, normally open Float switch, Class I, Div. 1, Groups A, B, C, D, normally closed Float switch, Class I, Div. 1, Groups A, B, C, D, normally open Float switch, ATEX/IECEX, 4-20 mA analog output (qualification required) Float switch, ATEX/IECEX, 4-20 mA discrete output (qualification required) No switch, flat back cover

Note: The Oil Level Monitor Cover is an assembly that replaces the previous back cover on T100 Series pumps. It contains a float switch assembly that can trigger an alarm or shutdown when pre-defined levels of high or low oil are reached. It may also be ordered without a float switch cover.

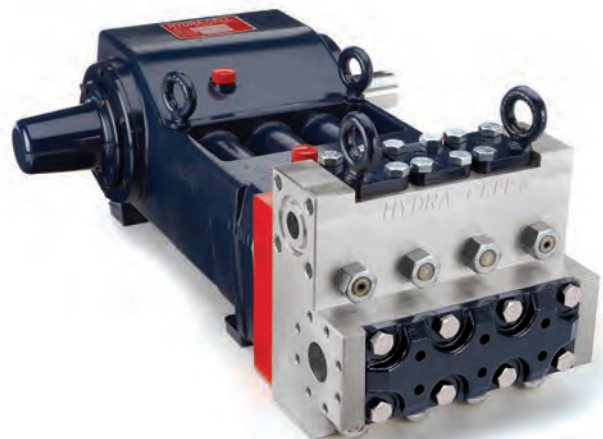

Q155 Low Pressure Performance

Capacities

Model	Max. Input rpm	Plunger Dia.		Max. Flow Capacities			Max. Pressure Ratings Discharge		Max. Pressure Ratings Inlet	
		Inches	mm	gpm	l/min	BPD	psi	bar	psi	bar
Q155E	450	2.500	64	157	595	5383	1500	103	500	34
Q155F	450	2.250	57	127	490	4354	1850	128	500	34
Q155H	450	2.125	54	111	421	3806	2100	145	500	34

Consult factory when operating below 45 rpm.

Maximum Flow at Designated Pressure

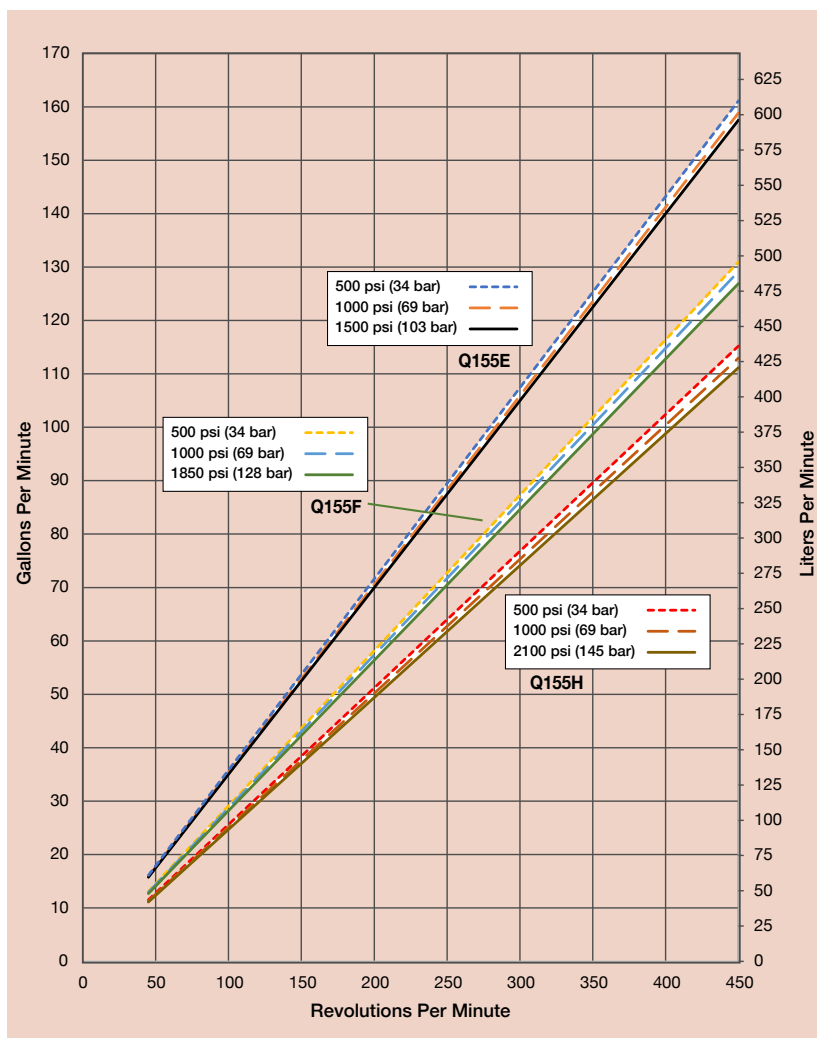

Q155 low pressure model shown with Nickel Aluminum Bronze (NAB) manifold. (Also available with Stainless Steel manifold.)

Net Positive Suction Head (NPSHr)

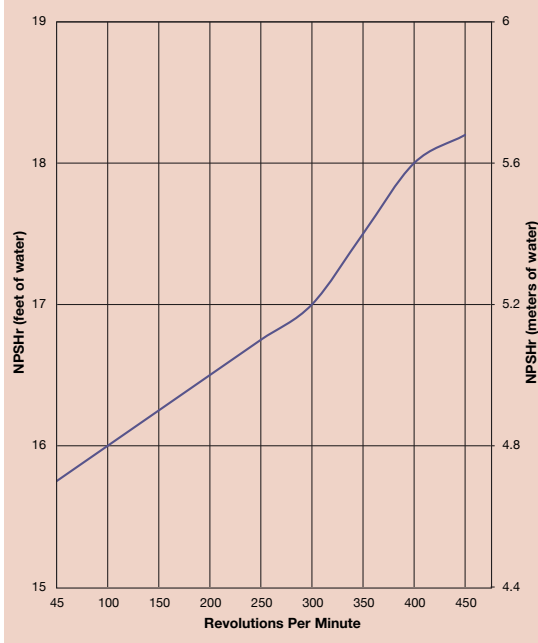

Q155 Series Low Pressure Specifications

Flow Capacities

Model	Pressure psi (bar)	rpm	gpm	l/min	BPD
Q155E	1500 (103)	450	157	595	5383
Q155F	1850 (128)	450	127	490	4354
Q155H	2100 (145)	450	111	421	3806

Delivery

	Pressure psi (bar)	gal/rev	liters/rev
Q155E	500 (34)	0.358	1.354
	1000 (69)	0.353	1.338
	1500 (103)	0.350	1.323
Q155F	500 (34)	0.291	1.102
	1000 (69)	0.287	1.085
	1850 (128)	0.282	1.068
Q155H	500 (34)	0.256	0.967
	1000 (69)	0.251	0.951
	2100 (145)	0.247	0.936

rpm

Maximum:	450
Minimum:	45 (Consult factory for speeds less than 45 rpm.)

Maximum Discharge Pressure

Metallic Heads:	Q155E	1500 psi (103 bar)
	Q155F	1850 psi (128 bar)
	Q155H	2100 psi (145 bar)

Maximum Inlet Pressure

500 psi (34 bar)

Operating Temperature

Maximum:	180 °F (82.2 °C)
Minimum:	40 °F (4.4 °C)

Consult factory for temperatures outside this range.

Maximum Solids Size

800 microns

Input Shaft

Left or Right Side

Inlet Ports

Weld-On: 4" / SCH. 40
4" NPT, 4" Class 300 RF ANSI Flange

Discharge Ports

Weld-On: 3" / SCH. 80
3" NPT, 3" Class 900 RF ANSI Flange

Plunger Stroke Length

3-1/2 inch (88.9 mm)

Shaft Diameter

3 inch (76.2 mm)

Shaft Rotation

Uni-directional (See rotation arrow.)

Oil Capacity

32 US quarts (30.3 liters) - blank back cover
34 US quarts (32.2 liters) - oil level back cover
See How to Order on page 141 for oil selection;
see page 100 for oil specification.

Weight

Metallic Heads: 1700 lbs. (771 kg)

Fluid End Materials

Diaphragm Follower Screw:	316 Stainless Steel
Outlet Valve Retainer:	316 Stainless Steel
Plug-Outlet Valve Port:	316 Stainless Steel
Inlet Valve Retainer:	316 Stainless Steel

See How to Order on page 141 for customer-specified fluid end materials choices.

Power End Materials

Crankshaft:	Forged Q&T Alloy Steel
Connecting Rods:	Ductile Iron
Crossheads:	12L14 Steel
Crankcase:	Ductile Iron
Bearings:	Spherical Roller/Bronze Journal (outer mains) Steel Backed Babbit (crankpin) Bronze (wristpin, center mains)

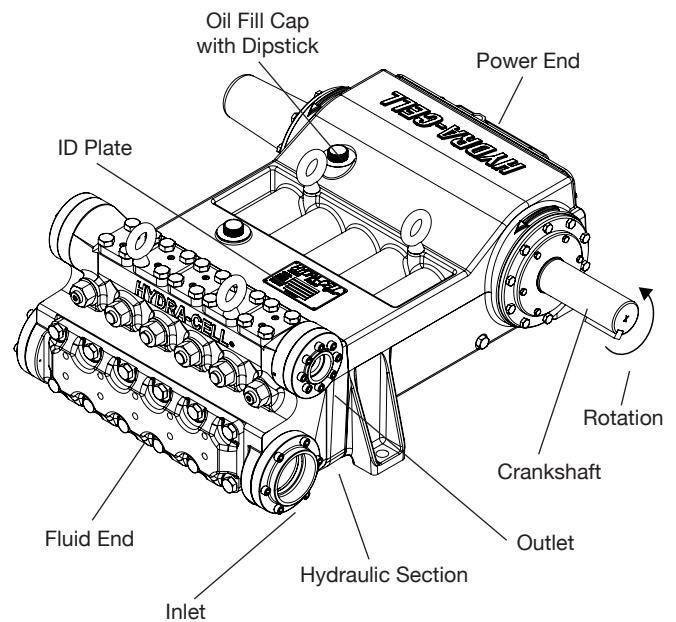

Calculating Required Horsepower (kW)*

$$\frac{\text{gpm} \times \text{psi}}{1,460} = \text{electric motor hp}^*$$

$$\frac{\text{lpm} \times \text{bar}}{511} = \text{electric motor kW}^*$$

* hp (kW) is required application power.

Attention!

When sizing motors with variable speed drives (VFD): It is very important to select a motor and a VFD rated for constant torque inverter duty service and that the motor is rated to meet the torque requirements of the pump throughout desired speed range.

QI55 Low Pressure Drawings

Threaded Version Inches (mm)

Front View

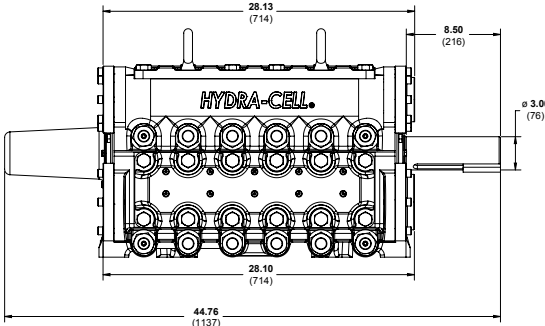

Side View

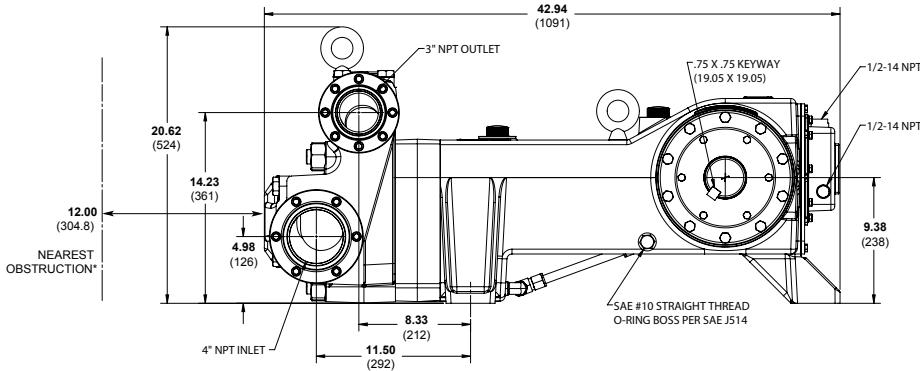

*Contact factory for obstruction distances closer than 12 inches (304.8 mm).

Bottom View

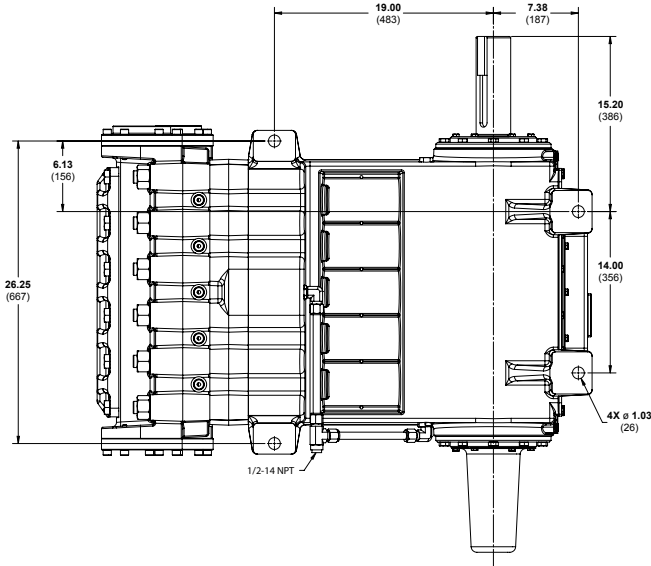

Note: Dimensions are for reference only. Contact factory for certified drawings.

Q155 Low Pressure **How to Order**

Ordering Information

1	2	3	4	5	6	7	8	9	10	11	12	13	14
Q	1	5	5										

A complete Q155 Series Low Pressure Model contains 14 digits including 10 customer-specified design and materials options, for example: Q155ERDGHFETAC.

Low Pressure

Digit	Order Code	Description
1-4	Q155	Pump Configuration Shaft-driven
5		Performance
	E	Max. 157 gpm (595 l/min) 5383 BPD @ 1500 psi (103 bar)
	F	Max. 127 gpm (490 l/min) 4354 BPD @ 1850 psi (128 bar)
	H	Max. 111 gpm (421 l/min) 3806 BPD @ 2100 psi (145 bar)
6		Pump Head Version
	A	NPT Threaded Ports (Steel)
	C	Weld Neck (Steel)
	D	Weld Neck (316L Stainless Steel)
	E	Weld Neck (Hastelloy C)
	F	Weld Neck (Duplex Alloy 2205 Stainless Steel)
	G	ANSI Flanged Ports (Duplex Alloy 2205 Stainless Steel)
	R	ANSI Flanged Ports (Steel)
	S	ANSI Flanged Ports (316L Stainless Steel)
	T	ANSI Flanged Ports (Hastelloy C)
7		Pump Head Material
	D	Nickel Aluminum Bronze (NAB)
	G	Duplex Alloy 2205 Stainless Steel
	S	316 Stainless Steel CF3M
	T	Hastelloy CX2M
8		Diaphragm & O-ring Material
	A	Aflas
	E	EPDM (requires EPDM-compatible oil - Digit 13 oil code D)
	G	FKM
	T	Buna-N
9		Valve Seat Material
	D	Tungsten Carbide*
	H	17-4 Stainless Steel
	N	Nitronic 50
	T	Hastelloy C
10		Valve Material
	D	Tungsten Carbide*
	F	17-4 Stainless Steel
	N	Nitronic 50
	T	Hastelloy C

*Tungsten Carbide valve seat and disc are a matched set and must be purchased together.

Digit	Order Code	Description
11		Valve Springs
	E	Elgiloy
	T	Hastelloy C
12		Valve Spring Retainers
	S	316 SST
	T	Hastelloy C
13		Hydra-Oil
	A	10W30 standard-duty oil
	B	40-wt. oil
	D	EPDM-compatible oil
	E	Food-contact oil
	H	15W50 high-temp severe-duty synthetic oil
14		Oil Level Monitor Cover
	C	Float switch, normally closed (recommended)
	O	Float switch, normally open
	S	Float switch, Class I, Div. 1, Groups A, B, C, D, normally closed
	T	Float switch, Class I, Div. 1, Groups A, B, C, D, normally open
	W	Float switch, ATEX/IECEX, 4-20 mA analog output (qualification required)
	X	Float switch, ATEX/IECEX, discrete output (qualification required)
	Y	No switch, flat back cover

Note: The Oil Level Monitor Cover is an assembly that replaces the previous back cover on Q155 Series pumps. It contains a float switch assembly that can trigger an alarm or shutdown when pre-defined levels of high or low oil are reached. It may also be ordered without a float switch cover.



Q155 Medium Pressure Performance

Capacities

Model	Max. Input rpm	Plunger Dia.		Max. Flow Capacities			Max. Pressure Ratings Discharge		Max. Pressure Ratings Inlet	
		Inches	mm	gpm	l/min	BPD	psi	bar	psi	bar
Q155K	450	1.750	44	78	295	2674	3000	207	500	34
Q155M	450	1.625	41	63	238	2160	3500	241	500	34

Consult factory when operating below 45 rpm.

Maximum Flow at Designated Pressure

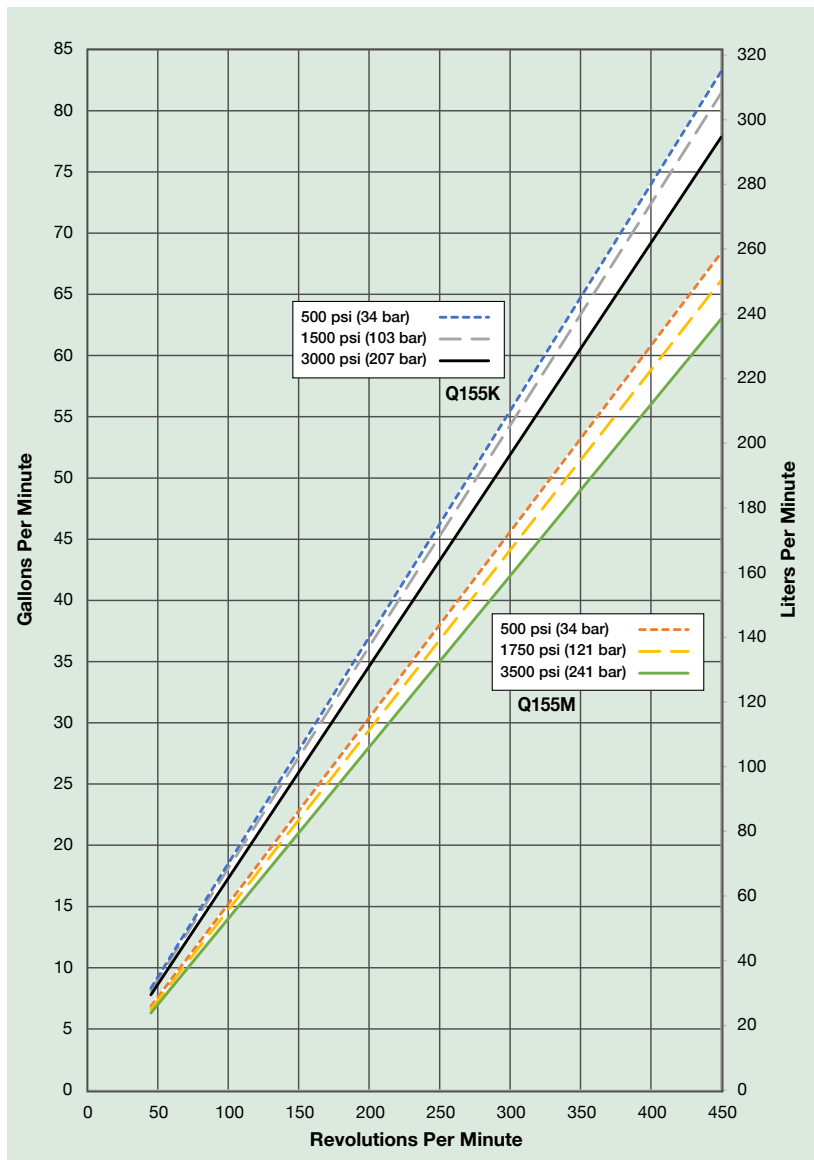

Q155 low pressure model shown with Stainless Steel manifold. (Also available with Nickel Aluminum Bronze/NAB manifold.)

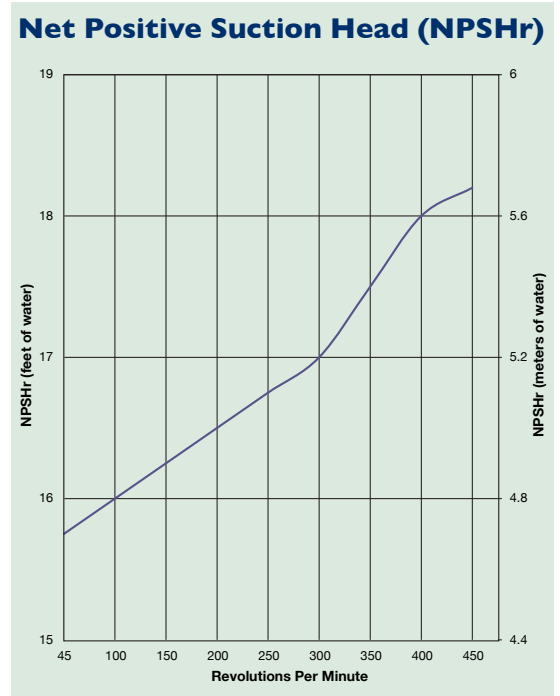

Q155 Series Medium Pressure Specifications

Flow Capacities

Model	Pressure psi (bar)	rpm	gpm	l/min	BPD
Q155K	3000 (207)	450	78	295	2674
Q155M	3500 (241)	450	63	238	2160

Delivery

	Pressure psi (bar)	gal/rev	liters/rev
Q155K	500 (34)	0.185	0.700
	1500 (103)	0.181	0.685
	3000 (207)	0.173	0.654
Q155M	500 (34)	0.152	0.575
	1750 (121)	0.147	0.556
	3500 (241)	0.140	0.530

rpm

Maximum:	450
Minimum:	45 (Consult factory for speeds less than 45 rpm.)

Maximum Discharge Pressure

Metallic Heads:	Q155K	3000 psi (207 bar)
	Q155M	3500 psi (241 bar)

Maximum Inlet Pressure

500 psi (34 bar)

Operating Temperature

Maximum:	180° F (82.2° C)
Minimum:	40° F (4.4° C)

Consult factory for temperatures outside this range.

Maximum Solids Size

800 microns

Input Shaft

Left or Right Side

Inlet Ports

Weld-On: 4" / SCH. 40
4" NPT, 4" Class 300 RF ANSI Flange

Discharge Ports

Weld-On: 2" / SCH. 160
2" NPT, 2" Class 2500 RTJ ANSI Flange

Plunger Stroke Length

3-1/2 inch (88.9 mm)

Shaft Diameter

3 inch (76.2 mm)

Shaft Rotation

Uni-directional (See rotation arrow.)

Oil Capacity

32 US quarts (30.3 liters) - blank back cover
34 US quarts (32.2 liters) - oil level back cover
See How to Order on page 145 for oil selection;
see page 100 for oil specification

Weight

Metallic Heads:	1700 lbs. (771 kg)
-----------------	--------------------

Fluid End Materials

Diaphragm Follower Screw:	316 Stainless Steel
Outlet Valve Retainer:	316 Stainless Steel
Plug-Outlet Valve Port:	316 Stainless Steel
Inlet Valve Retainer:	316 Stainless Steel
See How to Order on page 145 for customer-specified fluid end materials choices.	

Power End Materials

Crankshaft:	Forged Q&T Alloy Steel
Connecting Rods:	Ductile Iron
Crossheads:	12L14 Steel
Crankcase:	Ductile Iron
Bearings:	Spherical Roller/Bronze Journal (outer mains) Steel Backed Babbitt (crankpin) Bronze (wristpin, center mains)

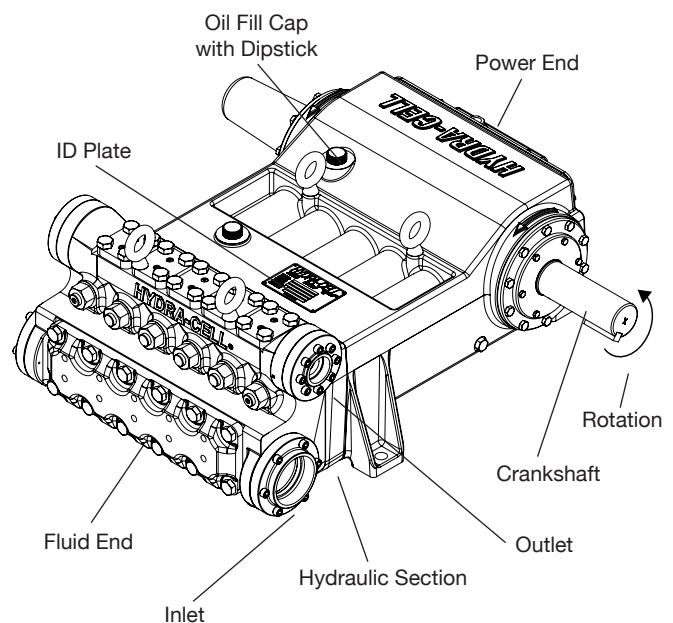

Calculating Required Horsepower (kW)*

$$\frac{\text{gpm} \times \text{psi}}{1,460} = \text{electric motor hp}^*$$

$$\frac{\text{lpm} \times \text{bar}}{511} = \text{electric motor kW}^*$$

* hp (kW) is required application power.

Attention!

When sizing motors with variable speed drives (VFD): It is very important to select a motor and a VFD rated for constant torque inverter duty service and that the motor is rated to meet the torque requirements of the pump throughout desired speed range.

QI55 Medium Pressure Drawings

Threaded Version Inches (mm)

Front View

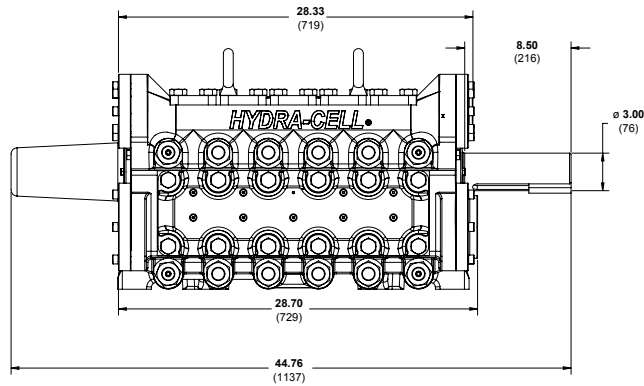

Side View

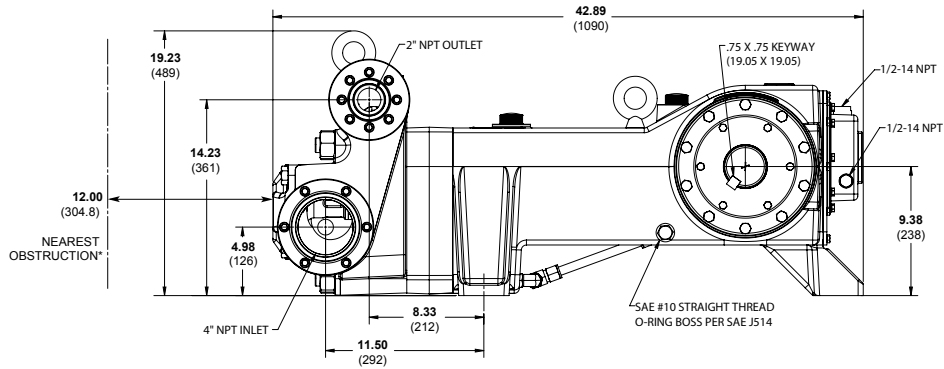

*Contact factory for obstruction distances closer than 12 inches (304.8 mm).

Bottom View

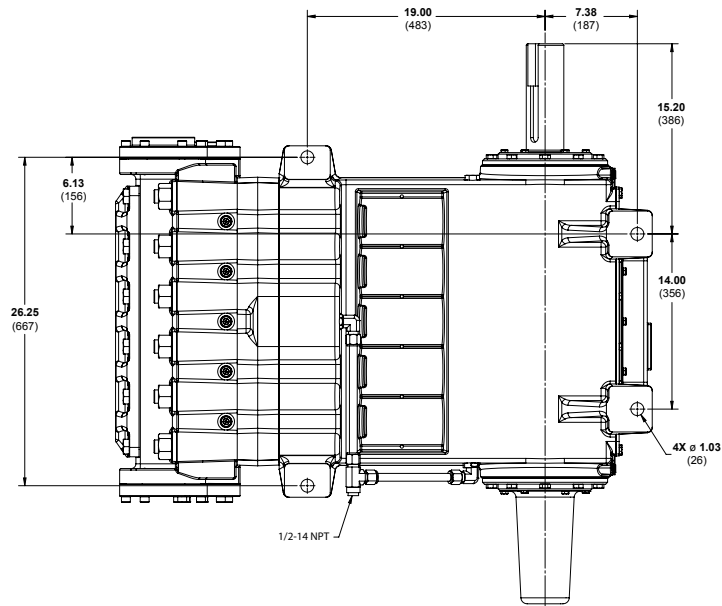

Note: Dimensions are for reference only. Contact factory for certified drawings.

Q155 Medium Pressure **How to Order**

Ordering Information

1	2	3	4	5	6	7	8	9	10	11	12	13	14
Q	1	5	5										

A complete Q155 Series Medium Pressure Model contains 14 digits including 10 customer-specified design and materials options, for example: Q155MRSTDDSEEC.

Medium Pressure

Digit	Order Code	Description
1-4	Q155	Pump Configuration Shaft-driven
5	K M	Performance Max. 78 gpm (295 l/min) 2674 BPD @ 3000 psi (207 bar) Max. 63 gpm (238 l/min) 2160 BPD @ 3500 psi (241 bar)
6	A C D E F G R S T	Pump Head Version NPT Threaded Ports (Steel) Weld Neck (Steel) Weld Neck (316L Stainless Steel) Weld Neck (Hastelloy C) Weld Neck (Duplex Alloy 2205 Stainless Steel) ANSI Flanged Ports (Duplex Alloy 2205 Stainless Steel) ANSI Flanged Ports (Steel) ANSI Flanged Ports (316L Stainless Steel) ANSI Flanged Ports (Hastelloy C)
7	D G S T	Pump Head Material Nickel Aluminum Bronze (NAB) Duplex Alloy 2205 Stainless Steel 316 Stainless Steel CF3M Hastelloy CX2M
8	A E G T	Diaphragm & O-ring Material Aflas EPDM (requires EPDM-compatible oil - Digit 13 oil code D) FKM Buna-N
9	D H N T	Valve Seat Material Tungsten Carbide* 17-4 Stainless Steel Nitronic 50 Hastelloy C
10	D F N T	Valve Material Tungsten Carbide* 17-4 Stainless Steel Nitronic 50 Hastelloy C

*Tungsten Carbide valve seat and disc are a matched set and must be purchased together.

Digit	Order Code	Description
11	E T	Valve Springs Elgiloy Hastelloy C
12	M P S T	Valve Spring Retainers PVDF Polypropylene 316 SST Hastelloy C
13	A B D E H	Hydra-Oil 10W30 standard-duty oil 40-wt. oil EPDM-compatible oil Food-contact oil 15W50 high-temp severe-duty synthetic oil
14	C O S T W X Y	Oil Level Monitor Cover Float switch, normally closed (recommended) Float switch, normally open Float switch, Class I, Div. 1, Groups A, B, C, D, normally closed Float switch, Class I, Div. 1, Groups A, B, C, D, normally open Float switch, ATEX/IECEX, 4-20 mA analog output (qualification required) Float switch, ATEX/IECEX, discrete output (qualification required) No switch, flat back cover

Note: The Oil Level Monitor Cover is an assembly that replaces the previous back cover on Q155 Series pumps. It contains a float switch assembly that can trigger an alarm or shutdown when pre-defined levels of high or low oil are reached. It may also be ordered without a float switch cover.



T200 Series Medium Pressure Performance

Capacities

Model	Max. Input rpm	Plunger Dia.		Max. Flow Capacities			Max. Pressure Ratings Discharge		Max. Pressure Ratings Inlet	
		Inches	mm	gpm	l/min	BPD	psi	bar	psi	bar
T200K	400	2.250	57	93	352	3189	3000	207	500	34
T200M	400	2.125	54	83	314	2846	3500	241	500	34

Consult factory when operating below 40 rpm.

Maximum Flow at Designated Pressure

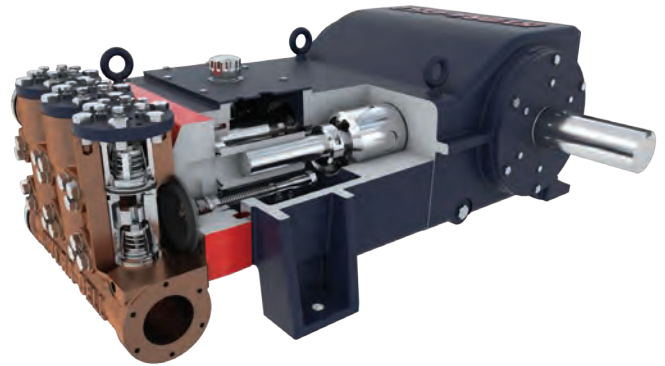
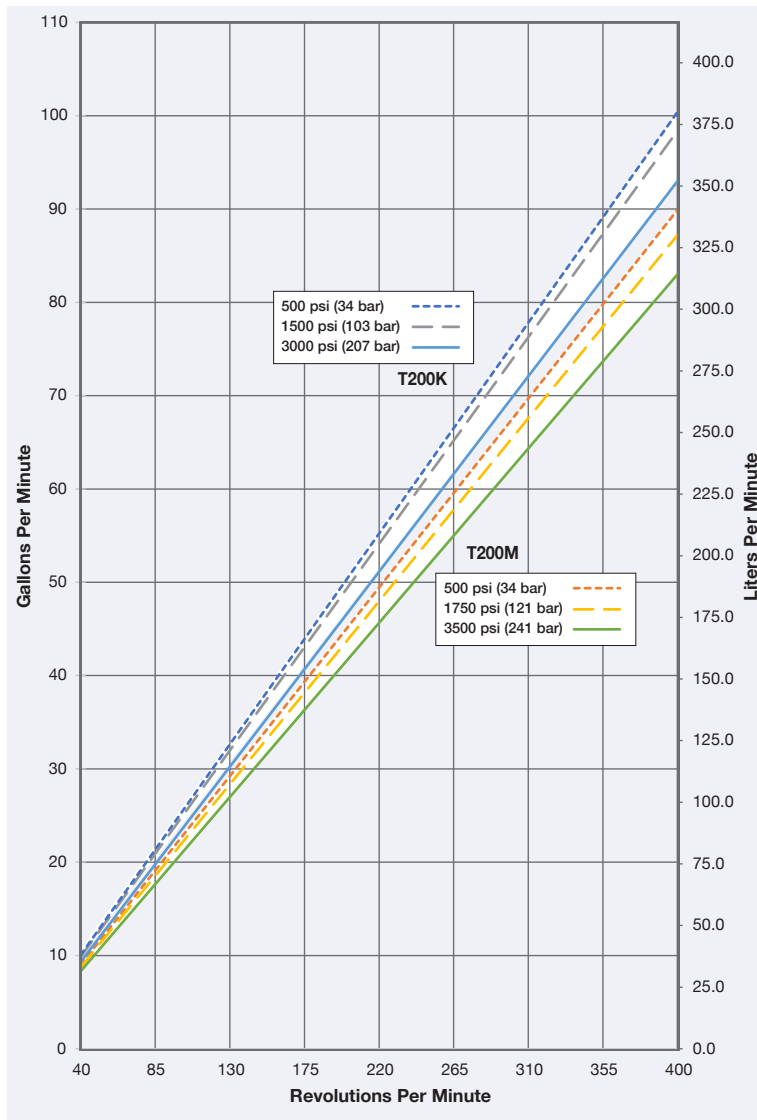

T200 Series pumps feature the Hydra-Cell seal-less design, eliminating clean-up costs from leaking seals or packing and protecting operators from dangerous fluids such as those containing hydrogen sulfide.

Net Positive Suction Head (NPSHr)

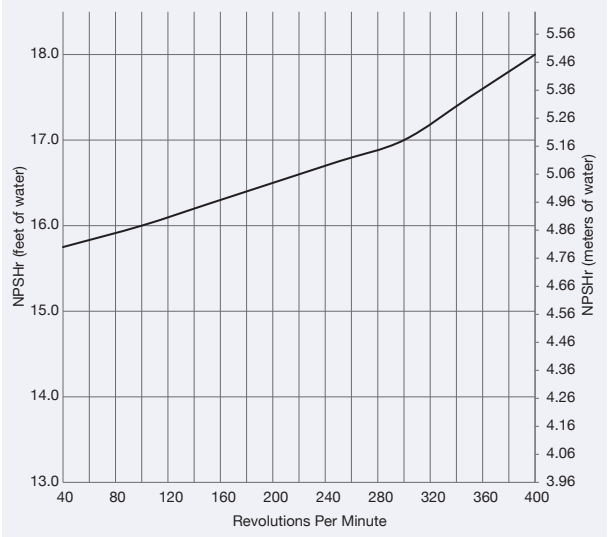

T200 Series Medium Pressure Specifications

Flow Capacities

Model	Pressure psi (bar)	rpm	gpm	l/min	BPD
T200K	3000 (207)	400	93	352	3189
T200M	3500 (241)	400	83	314	2846

Delivery

	Pressure psi (bar)	gal/rev	liters/rev
T200K	500 (34)	0.251	0.950
	1500 (103)	0.246	0.931
	3000 (207)	0.233	0.880
T200M	500 (34)	0.225	0.851
	1750 (121)	0.218	0.825
	3500 (241)	0.208	0.785

rpm

Maximum:	400
Minimum:	40 (Consult factory for speeds less than 40 rpm.)

Maximum Discharge Pressure

Metallic Heads:	T200K	3000 psi (207 bar)
	T200M	3500 psi (241 bar)

Maximum Inlet Pressure

500 psi (34 bar)

Operating Temperature

Maximum:	180 °F (82.2 °C)
Minimum:	40 °F (4.4 °C)

Consult factory for temperatures outside this range.

Maximum Solids Size

800 microns

Input Shaft

Right Side

Inlet Ports

Weld-On: 4" / SCH. 40
4" NPT, 4" Class 300 RF ANSI Flange

Discharge Ports

Weld-On: 2" / SCH. 160
2" NPT, 2" Class 2500 RTJ ANSI Flange

Plunger Stroke Length

5 inch (127 mm)

Shaft Diameter

4 inch (101.6 mm)

Shaft Rotation

Uni-directional (See rotation arrow.)

Oil Capacity

80 US quarts (75.7 liters) - blank back cover
See How to Order on page 149 for oil selection;
see page 100 for oil specification

Weight

Metallic Heads: 3000 lbs. (1361 kg)

Fluid End Materials

Diaphragm Follower Screw:	316 Stainless Steel
	Duplex Alloy 2205 Stainless Steel
	Hastelloy C
Valve Spring Retainer:	Hastelloy C / PVDF
Inlet/Outlet Valve Retainer:	316 Stainless Steel
	Duplex Alloy 2205 Stainless Steel
	Hastelloy C

See How to Order on page 149 for customer-specified fluid end material choices.

Power End Materials

Crankshaft:	Ductile Iron
Connecting Rods:	Ductile Iron
Crossheads:	Ductile Iron
Crankcase:	Ductile Iron
Bearings:	Spherical Roller (main)
	Steel-backed Tri-metal (crankpin)
	Bronze (wristpin)

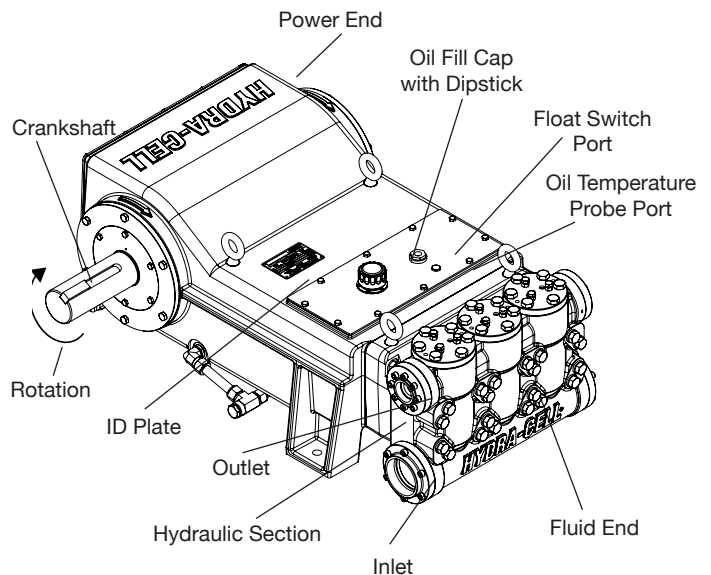

Calculating Required Horsepower (kW)*

$$\frac{\text{gpm} \times \text{psi}}{1,460} = \text{electric motor hp}^*$$

$$\frac{\text{lpm} \times \text{bar}}{511} = \text{electric motor kW}^*$$

* hp (kW) is required application power.

Attention!

When sizing motors with variable speed drives (VFD): It is very important to select a motor and a VFD rated for constant torque inverter duty service and that the motor is rated to meet the torque requirements of the pump throughout desired speed range.

T200 Series Medium Pressure Representative Drawings

Threaded Version Inches (mm)

Side View

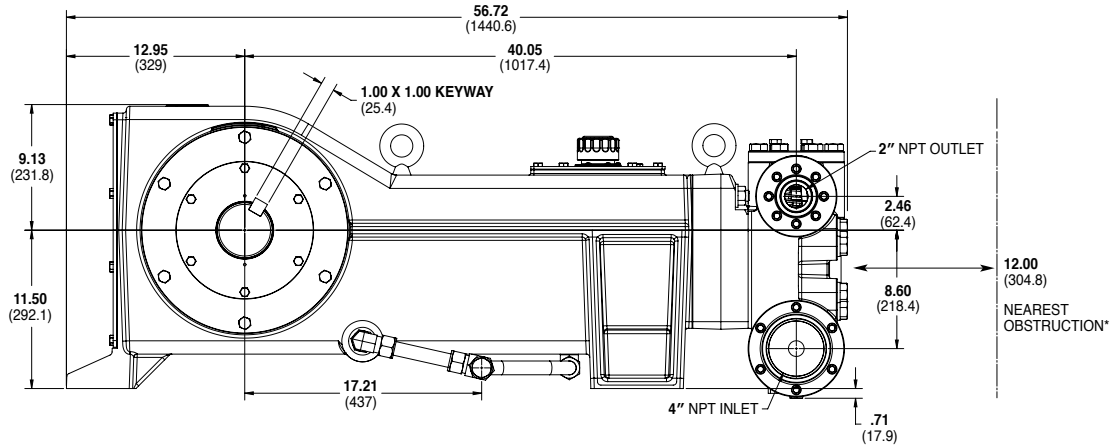

Front View

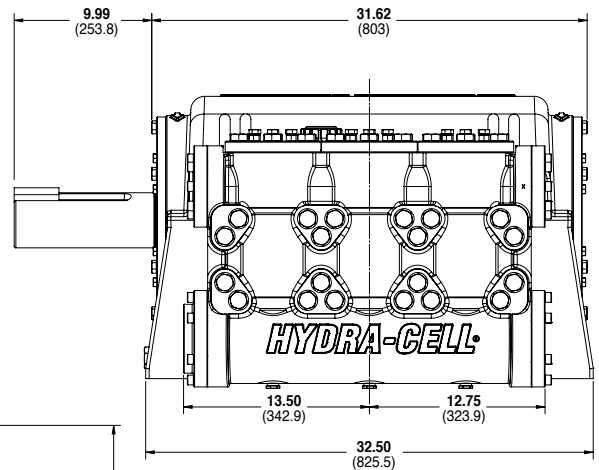

Bottom View

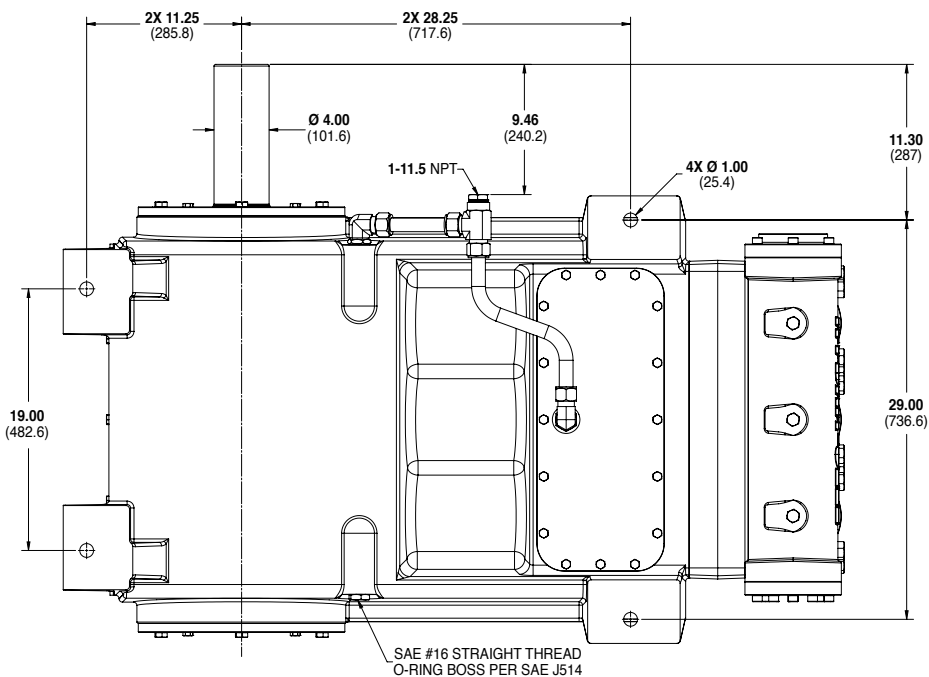

Note: Dimensions are for reference only. Contact factory for certified drawings.

T200 Series Medium Pressure **How to Order**

Ordering Information

1	2	3	4	5	6	7	8	9	10	11	12	13	14
T	2	0	0								T		

A complete T200 Series Medium Pressure Model Number contains 14 digits including 9 customer-specified design and materials options, for example: T200KADGHFETAC.

Medium Pressure

Digit	Order Code	Description
1-4		Pump Configuration
	T200	Shaft-driven
5		Performance
	K	Max. 93 gpm (352 l/min) 3189 BPD @ 3000 psi (207 bar)
	M	Max. 83 gpm (314 l/min) 2846 BPD @ 3500 psi (241 bar)
6		Pump Head Version
	A	NPT Threaded Ports (Steel)
	C	Weld Neck (Steel)
	D	Weld Neck (316L Stainless Steel)
	E	Weld Neck (Hastelloy C)
	F	Weld Neck (Duplex Alloy 2205 Stainless Steel)
	G	ANSI Flanged Ports (Duplex Alloy 2205 Stainless Steel)
	T	ANSI Flanged Ports (Hastelloy C)
7		Pump Head Material
	D	Nickel Aluminum Bronze (NAB)
	G	Duplex Alloy 2205 Stainless Steel
	S	CF3M (316L) Stainless Steel
	T	Hastelloy CX2M
8		Diaphragm & O-ring Material
	G	FKM
	T	Buna-N
9		Valve Seat Material
	H	17-4 Stainless Steel
	N	Nitronic 50
	T	Hastelloy C
10		Valve Material
	F	17-4 Stainless Steel
	N	Nitronic 50
	T	Hastelloy C

Digit	Order Code	Description
11		Valve Springs
	E	Elgiloy
	T	Hastelloy C
12		Valve Spring Retainers / Valve Guide
	T	Hastelloy C / PVDF
13		Hydra-Oil
	A	10W30 standard-duty oil
	B	40-wt. oil
	H	15W50 high-temp severe-duty synthetic oil
14		Oil Level Monitoring
	C	Float switch, normally closed (recommended)
	O	Float Switch, normally open
	Y	No switch, flat back cover



T200 Series High Pressure Performance

Capacities

Model	Max. Input rpm	Plunger Dia.		Max. Flow Capacities			Max. Pressure Ratings Discharge		Max. Pressure Ratings Inlet	
		Inches	mm	gpm	l/min	BPD	psi	bar	psi	bar
T200P	400	2.000	51	72	272	2469	4000	276	500	34
T200Q	400	1.875	48	63	238	2160	4500	310	500	34

Consult factory when operating below 40 rpm.

Maximum Flow at Designated Pressure

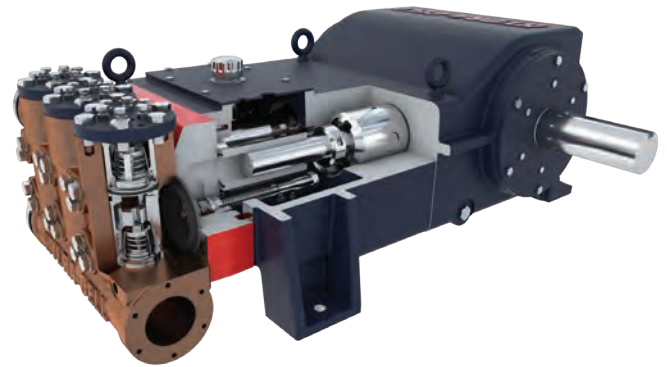
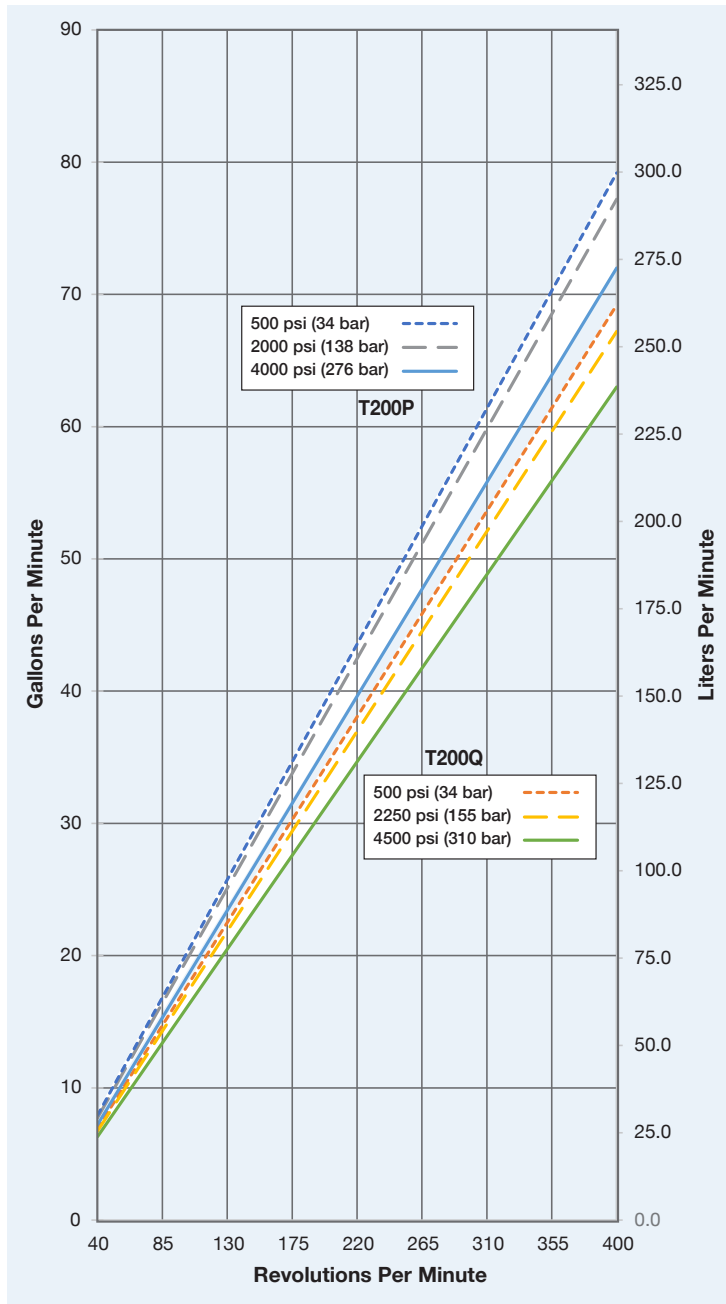

T200 Series pumps feature the Hydra-Cell seal-less design, eliminating clean-up costs from leaking seals or packing and protecting operators from dangerous fluids such as those containing hydrogen sulfide.

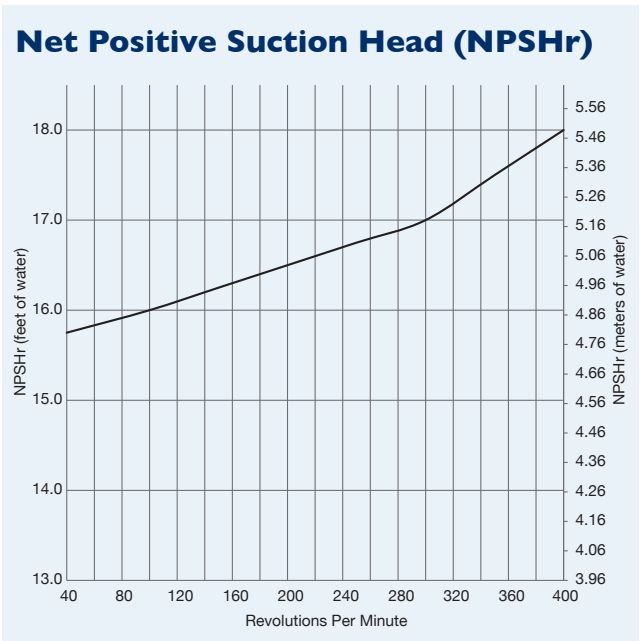

T200 Series High Pressure Specifications

Flow Capacities

Model	Pressure psi (bar)	rpm	gpm	l/min	BPD
T200P	4000 (276)	400	72	272	2469
T200Q	4500 (310)	400	63	238	2160

Delivery

	Pressure psi (bar)	gal/rev	liters/rev
T200P	500 (34)	0.198	0.749
	2000 (138)	0.193	0.731
	4000 (276)	0.180	0.681
T200Q	500 (34)	0.173	0.655
	2250 (155)	0.168	0.636
	4500 (310)	0.158	0.596

rpm

Maximum:	400
Minimum:	40 (Consult factory for speeds less than 40 rpm.)

Maximum Discharge Pressure

Metallic Heads:	T200P	4000 psi (276 bar)
	T200Q	4500 psi (310 bar)

Maximum Inlet Pressure

500 psi (34 bar)

Operating Temperature

Maximum:	180 °F (82.2 °C)
Minimum:	40 °F (4.4 °C)

Consult factory for temperatures outside this range.

Maximum Solids Size

800 microns

Input Shaft

Right Side

Inlet Ports

Weld-On: 4" / SCH. 40
4" NPT, 4" Class 300 RF ANSI Flange

Discharge Ports

Weld-On: 2" / SCH. 160
2" NPT, 2" Class 2500 RTJ ANSI Flange

Plunger Stroke Length

5 inch (127 mm)

Shaft Diameter

4 inch (101.6 mm)

Shaft Rotation

Uni-directional (See rotation arrow.)

Oil Capacity

80 US quarts (75.7 liters) - blank back cover
See How to Order on page 153 for oil selection;
see page 100 for oil specification

Weight

Metallic Heads: 3000 lbs. (1361 kg)

Fluid End Materials

Diaphragm Follower Screw:	316 Stainless Steel
	Duplex Alloy 2205 Stainless Steel
	Hastelloy C
Valve Spring Retainer:	Hastelloy C / PVDF
Inlet/Outlet Valve Retainer:	316 Stainless Steel
	Duplex Alloy 2205 Stainless Steel
	Hastelloy C

See How to Order on page 153 for customer-specified fluid end material choices.

Power End Materials

Crankshaft:	Ductile Iron
Connecting Rods:	Ductile Iron
Crossheads:	Ductile Iron
Crankcase:	Ductile Iron
Bearings:	Spherical Roller (main)
	Steel-backed Tri-metal (crankpin)
	Bronze (wristpin)

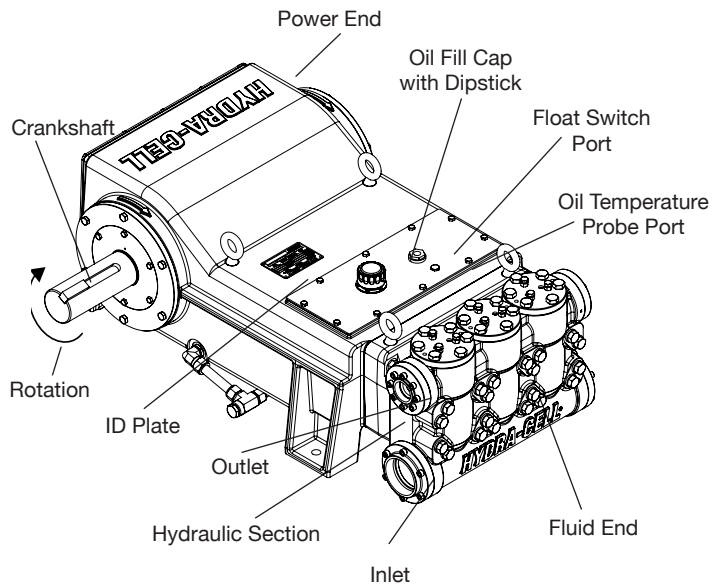

Calculating Required Horsepower (kW)*

$$\frac{\text{gpm} \times \text{psi}}{1,460} = \text{electric motor hp}^*$$

$$\frac{\text{lpm} \times \text{bar}}{511} = \text{electric motor kW}^*$$

* hp (kW) is required application power.

Attention!

When sizing motors with variable speed drives (VFD): It is very important to select a motor and a VFD rated for constant torque inverter duty service and that the motor is rated to meet the torque requirements of the pump throughout desired speed range.

T200 Series High Pressure Representative Drawings

Threaded Version Inches (mm)

Side View

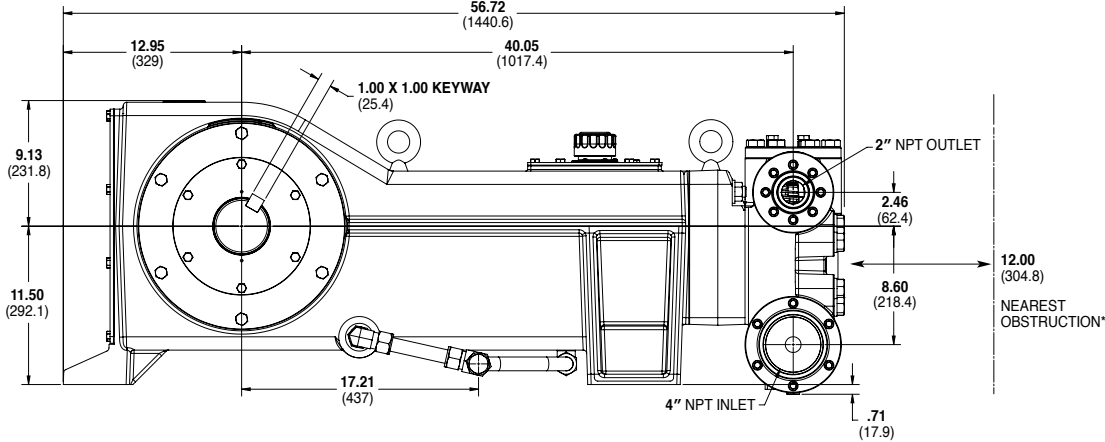

Front View

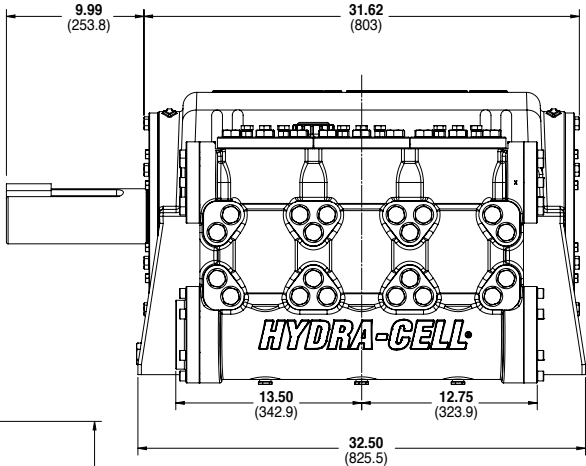

Bottom View

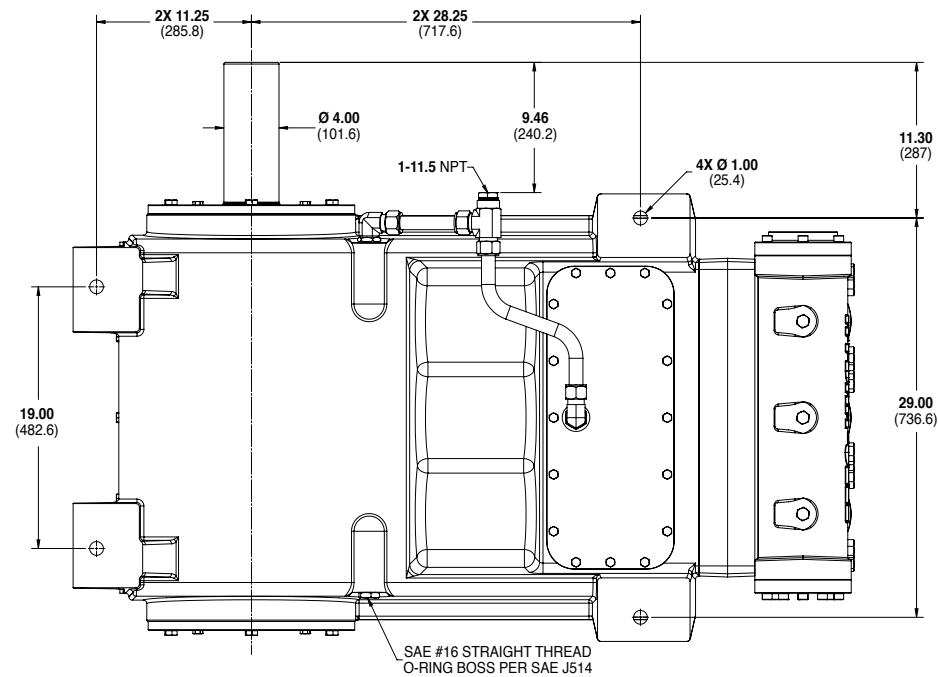

Note: Dimensions are for reference only. Contact factory for certified drawings.

T200 Series High Pressure **How to Order**

Ordering Information

1	T	2	2	3	0	4	0	5		6		7		8		9		10		11		12	T	13		14	
---	---	---	---	---	---	---	---	---	--	---	--	---	--	---	--	---	--	----	--	----	--	----	---	----	--	----	--

A complete T200 Series High Pressure Model Number contains 14 digits including 9 customer-specified design and materials options, for example: T200PADGHFETAC.

High Pressure

Digit	Order Code	Description
1-4		Pump Configuration
	T200	Shaft-driven
5		Performance
	P	Max. 72 gpm (272 l/min) 2469 BPD @ 4000 psi (276 bar)
	Q	Max. 63 gpm (238 l/min) 2160 BPD @ 4500 psi (310 bar)
6		Pump Head Version
	A	NPT Threaded Ports (Steel)
	C	Weld Neck (Steel)
	D	Weld Neck (316L Stainless Steel)
	E	Weld Neck (Hastelloy C)
	F	Weld Neck (Duplex Alloy 2205 Stainless Steel)
	G	ANSI Flanged Ports (Duplex Alloy 2205 Stainless Steel)
	T	ANSI Flanged Ports (Hastelloy C)
7		Pump Head Material
	D	Nickel Aluminum Bronze (NAB)
	G	Duplex Alloy 2205 Stainless Steel
	S	CF3M (316L) Stainless Steel
	T	Hastelloy CX2M
8		Diaphragm & O-ring Material
	G	FKM
	T	Buna-N
9		Valve Seat Material
	H	17-4 Stainless Steel
	N	Nitronic 50
	T	Hastelloy C
10		Valve Material
	F	17-4 Stainless Steel
	N	Nitronic 50
	T	Hastelloy C

Digit	Order Code	Description
11		Valve Springs
	E	Elgiloy
	T	Hastelloy C
12		Valve Spring Retainers / Valve Guide
	T	Hastelloy C / PVDF
13		Hydra-Oil
	A	10W30 standard-duty oil
	B	40-wt. oil
	H	15W50 high-temp severe-duty synthetic oil
14		Oil Level Monitoring
	C	Float switch, normally closed (recommended)
	O	Float Switch, normally open
	Y	No switch, flat back cover



Q330 Medium Pressure Performance

Capacities

Model	Max. Input rpm	Plunger Dia.		Max. Flow Capacities			Max. Pressure Ratings Discharge		Max. Pressure Ratings Inlet	
		Inches	mm	gpm	l/min	BPD	psi	bar	psi	bar
Q330K	400	2.250	57	153	579	5247	3000	207	500	34
Q330M	400	2.125	54	136	514	4664	3500	241	500	34

Consult factory when operating below 40 rpm.

Maximum Flow at Designated Pressure

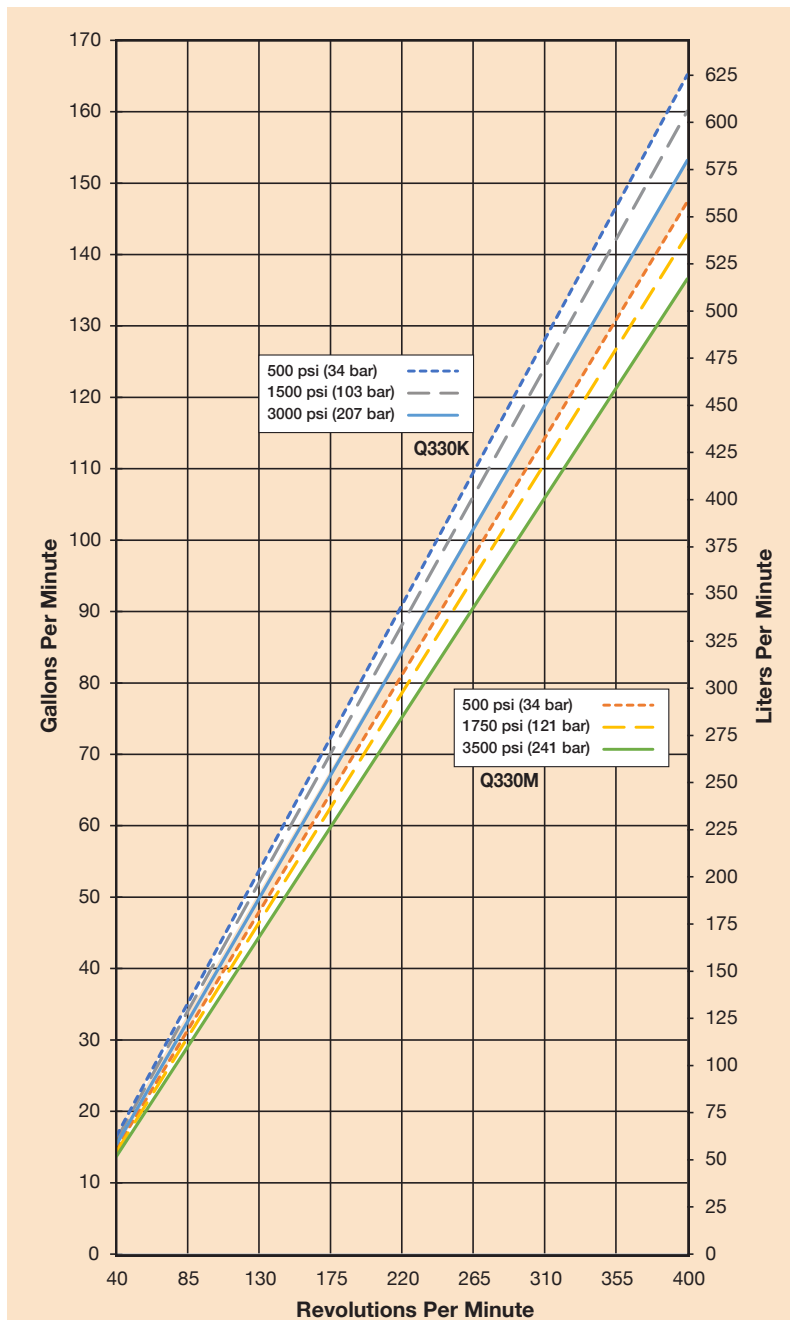

Q330 Series pumps feature the Hydra-Cell seal-less design, eliminating clean-up costs from leaking seals or packing and protecting operators from dangerous fluids such as those containing hydrogen sulfide.

Net Positive Suction Head (NPSHr)

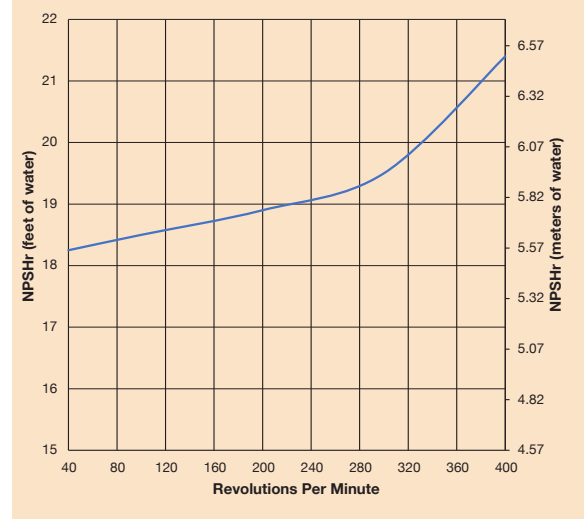

Q330 Medium Pressure Specifications

Flow Capacities

Model	Pressure psi (bar)	rpm	gpm	l/min	BPD
Q330K	3000 (207)	400	153	579	5247
Q330M	3500 (241)	400	136	514	4664

Delivery

	Pressure psi (bar)	gal/rev	liters/rev
Q330K	500 (34)	0.413	1.563
	1500 (103)	0.400	1.515
	3000 (207)	0.383	1.450
Q330M	500 (34)	0.369	1.395
	1750 (121)	0.357	1.351
	3500 (241)	0.342	1.293

rpm

Maximum:	400
Minimum:	40 (Consult factory for speeds less than 40 rpm.)

Maximum Discharge Pressure

Metallic Heads:	Q330K	3000 psi (207 bar)
	Q330M	3500 psi (241 bar)

Maximum Inlet Pressure

500 psi (34 bar)

Operating Temperature

Maximum:	180 °F (82.2 °C)
Minimum:	40 °F (4.4 °C)

Consult factory for temperatures outside this range.

Maximum Solids Size

800 microns

Input Shaft

Right Side

Inlet Ports

Weld-On: 6 inch / SCH. 40

6 inch NPT, 6 inch Class 300 RF ANSI

Discharge Ports

Weld-On: 3 inch / SCH. XXH

3 inch NPT, 3 inch Class 2500 RTJ ANSI
--

Plunger Stroke Length

5 inch (127 mm)

Shaft Diameter

4 inch (101.6 mm)

Shaft Rotation

Uni-directional (See rotation arrow.)

Oil Capacity

110 US quarts (104.1 liters)

Weight

Metallic Heads: 5000 lbs. (2268 kg)

Calculating Required Horsepower (kW)*

$$\frac{\text{gpm} \times \text{psi}}{1,460} = \text{electric motor hp}^*$$

$$\frac{\text{lpm} \times \text{bar}}{511} = \text{electric motor kW}^*$$

* hp (kW) is required application power.

Attention!

When sizing motors with variable speed drives (VFD): It is very important to select a motor and a VFD rated for constant torque inverter duty service and that the motor is rated to meet the torque requirements of the pump throughout desired speed range.

Fluid End Materials

Manifold:	Nickel Aluminum Bronze (NAB)
Diaphragm/Elastomers:	FKM Buna-N
Diaphragm Follower Screw:	316 Stainless Steel
Valve Spring Retainer:	Hastelloy C
Check Valve Spring:	Elgiloy Hastelloy C
Valve Disc/Seat:	17-4 Stainless Steel Nitronic 50 Hastelloy C
Outlet Valve Retainer:	Austenitic Stainless Steel
Plug-Outlet Valve Port:	316 Stainless Steel
Inlet Valve Retainer:	Austenitic Stainless Steel

Power End Materials

Crankshaft:	Ductile Iron
Connecting Rods:	Ductile Iron
Crossheads:	Ductile Iron
Crankcase:	Ductile Iron
Bearings:	Spherical Roller Journal (outer mains) Steel Backed Tri-metal (crankpin) Bronze (wristpin, center mains)

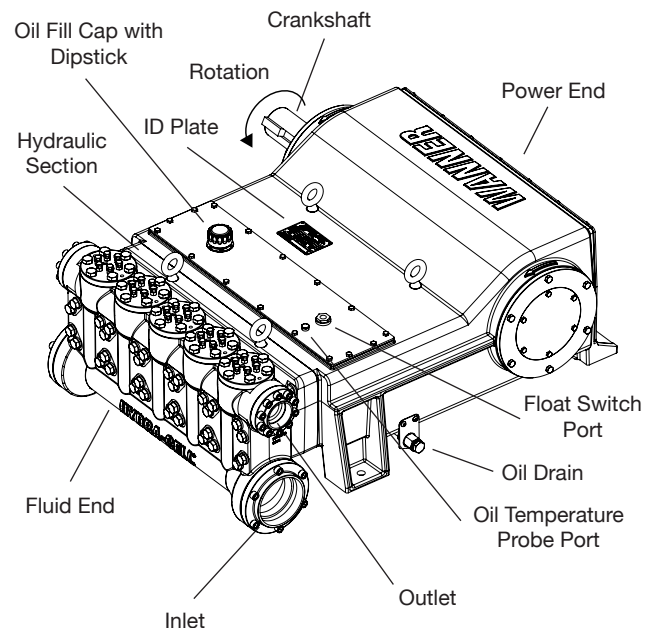

Q330 Medium Pressure Drawings

Threaded Version Inches (mm)

Front View

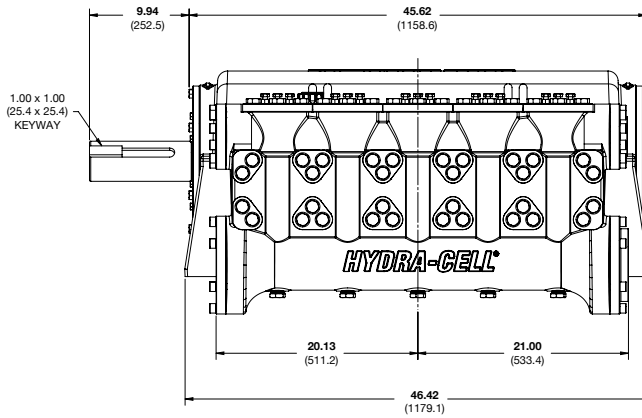

Side View

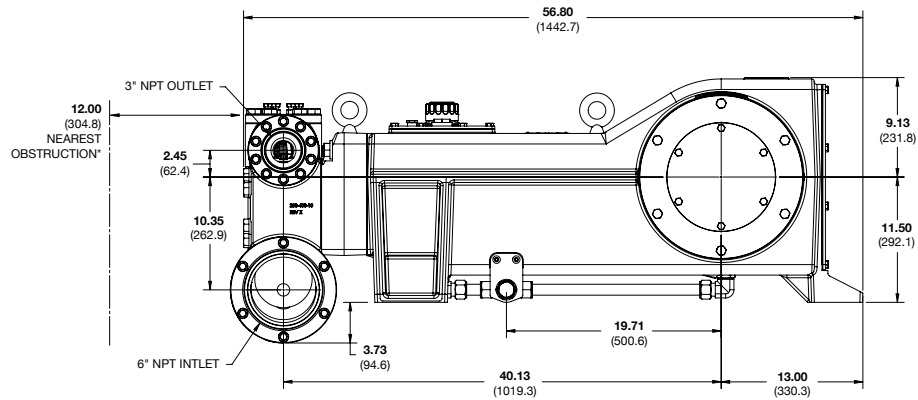

*Contact factory for obstruction distances closer than 12 inches (304.8 mm).

Bottom View

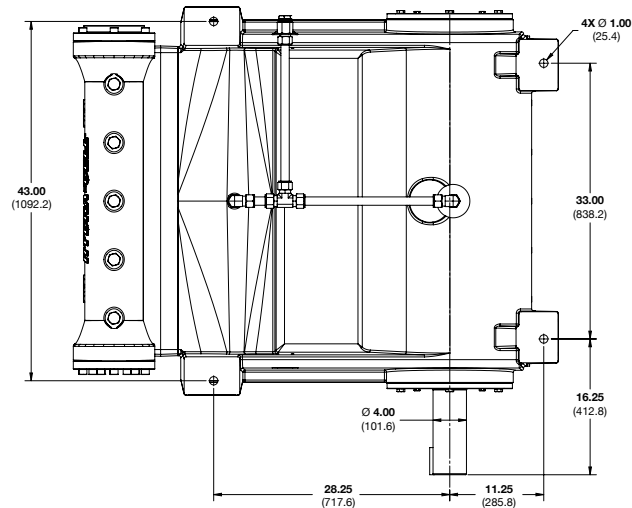

Note: Dimensions are for reference only. Contact factory for certified drawings.

Q330 Medium Pressure **How to Order**

Ordering Information

1	2	3	4	5	6	7	8	9	10	11	12	13	14
Q	3	3	0			D					T		

A complete Q330 Series Medium Pressure Model Number contains 14 digits including 8 customer-specified design and materials options, for example: Q330KDDGHFETA.

Medium Pressure

Digit	Order Code	Description
1-4	Q330	Pump Configuration Shaft-driven
5	K	Performance Max. 153 gpm (579 l/min) 5247 BPD @ 3000 psi (207 bar)
	M	Max. 136 gpm (514 l/min) 4664 BPD @ 3500 psi (241 bar)
6	A	Pump Head Version NPT Ports (Steel)
	C	Weld Neck (Steel)
	D	Weld Neck (316L Stainless Steel)
	E	Weld Neck (Hastelloy C)
	F	Weld Neck (Duplex Alloy 2205 Stainless Steel)
	G	ANSI Flanged Ports (Duplex Alloy 2205 Stainless Steel)
	T	ANSI Flanged Ports (Hastelloy C)
7	D	Pump Head Material Nickel Aluminum Bronze (NAB)
8	G	Diaphragm & O-ring Material FKM
	T	Buna-N
9	H	Valve Seat Material 17-4 Stainless Steel
	N	Nitronic 50
	T	Hastelloy C
10	F	Valve Material 17-4 Stainless Steel
	N	Nitronic 50
	T	Hastelloy C
11	E	Valve Springs Elgiloy
	T	Hastelloy C
12	T	Valve Spring Retainers / Valve Guide Hastelloy C / PVDF

Digit	Order Code	Description
13	A	Hydra-Oil 10W30 standard-duty oil
	B	40-wt. oil
	H	15W50 high-temp severe-duty synthetic oil
14	C	Oil Level Monitor Cover Float switch, normally closed (recommended)
	O	Float switch, normally open
	Y	No switch, flat back cover



Q330 High Pressure Performance

Capacities

Model	Max. Input rpm	Plunger Dia.		Max. Flow Capacities			Max. Pressure Ratings Discharge		Max. Pressure Ratings Inlet	
		Inches	mm	gpm	l/min	BPD	psi	bar	psi	bar
Q330P	400	2.000	51	117	442	4011	4000	276	500	34
Q330Q	400	1.875	48	104	393	3566	4500	310	500	34

Consult factory when operating below 40 rpm.

Maximum Flow at Designated Pressure

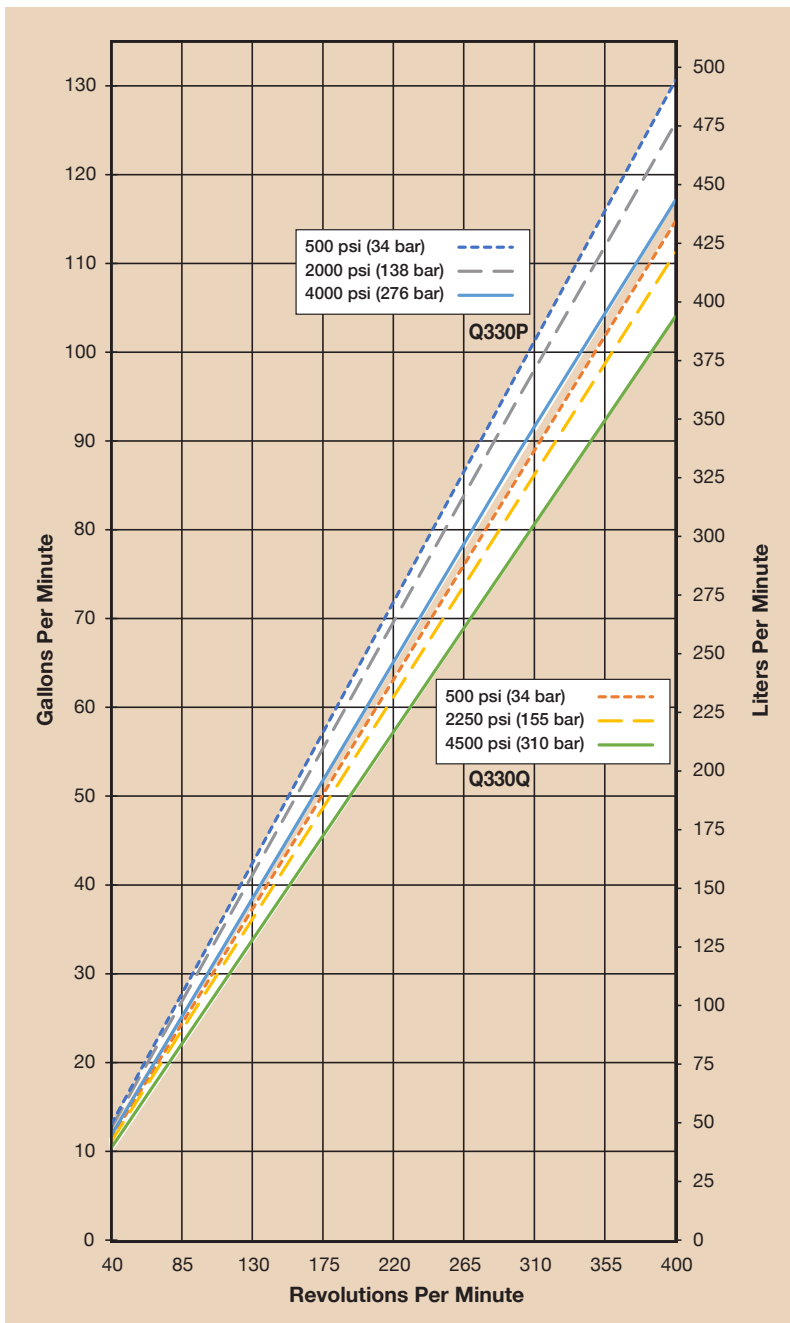

Q330 Series pumps feature the Hydra-Cell seal-less design, eliminating clean-up costs from leaking seals or packing and protecting operators from dangerous fluids such as those containing hydrogen sulfide.

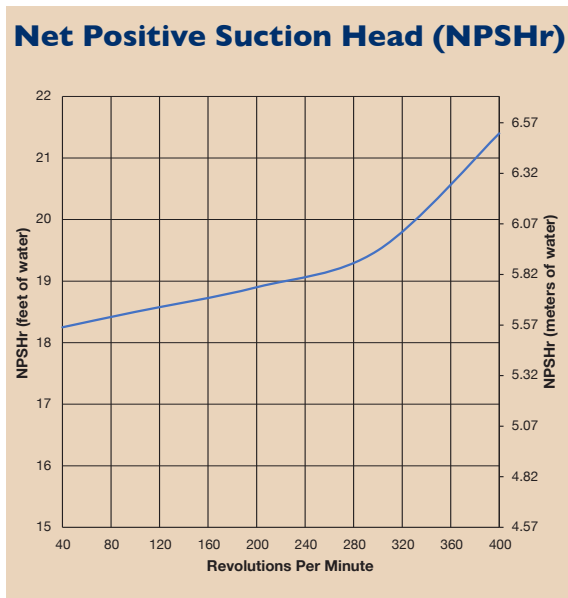

Q330 High Pressure Specifications

Flow Capacities

Model	Pressure psi (bar)	rpm	gpm	l/min	BPD
Q330P	4000 (276)	400	117	442	4011
Q330Q	4500 (310)	400	104	393	3566

Delivery

	Pressure psi (bar)	gal/rev	liters/rev
Q330P	500 (34)	0.327	1.236
	2000 (138)	0.314	1.187
	4000 (276)	0.293	1.107
Q330Q	500 (34)	0.287	1.085
	2250 (155)	0.278	1.052
	4500 (310)	0.260	0.984

rpm

Maximum:	400
Minimum:	40 (Consult factory for speeds less than 40 rpm.)

Maximum Discharge Pressure

Metallic Heads:	Q330P	4000 psi (276 bar)
	Q330Q	4500 psi (310 bar)

Maximum Inlet Pressure

500 psi (34 bar)

Operating Temperature

Maximum:	180 °F (82.2 °C)
Minimum:	40 °F (4.4 °C)

Consult factory for temperatures outside this range.

Maximum Solids Size

800 microns

Input Shaft

Right Side

Inlet Ports

Weld-On: 6 inch / SCH. 40

6 inch NPT, 6 inch Class 300 RF ANSI

Discharge Ports

Weld-On: 3 inch / SCH. XXH

3 inch NPT, 3 inch Class 2500 RTJ ANSI
--

Plunger Stroke Length

5 inch (127 mm)

Shaft Diameter

4 inch (101.6 mm)

Shaft Rotation

Uni-directional (See rotation arrow.)

Oil Capacity

110 US quarts (104.1 liters)

Weight

Metallic Heads:	5000 lbs. (2268 kg)
-----------------	---------------------

Calculating Required Horsepower (kW)*

$$\frac{\text{gpm} \times \text{psi}}{1,460} = \text{electric motor hp}^*$$

$$\frac{\text{lpm} \times \text{bar}}{511} = \text{electric motor kW}^*$$

* hp (kW) is required application power.

Attention!

When sizing motors with variable speed drives (VFD): It is very important to select a motor and a VFD rated for constant torque inverter duty service and that the motor is rated to meet the torque requirements of the pump throughout desired speed range.

Fluid End Materials

Manifold:	Nickel Aluminum Bronze (NAB)
Diaphragm/Elastomers:	FKM Buna-N
Diaphragm Follower Screw:	316 Stainless Steel
Valve Spring Retainer:	Hastelloy C
Check Valve Spring:	Elgiloy Hastelloy C
Valve Disc/Seat:	17-4 Stainless Steel Nitronic 50 Hastelloy C
Outlet Valve Retainer:	Austenitic Stainless Steel
Plug-Outlet Valve Port:	316 Stainless Steel
Inlet Valve Retainer:	Austenitic Stainless Steel

Power End Materials

Crankshaft:	Ductile Iron
Connecting Rods:	Ductile Iron
Crossheads:	Ductile Iron
Crankcase:	Ductile Iron
Bearings:	Spherical Roller Journal (outer mains) Steel Backed Tri-metal (crankpin) Bronze (wristpin, center mains)

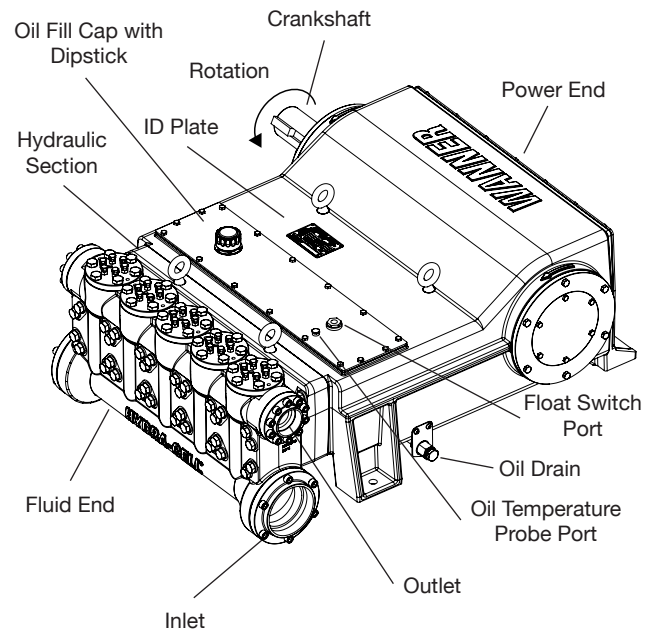

Q330 High Pressure Drawings

Threaded Version Inches (mm)

Front View

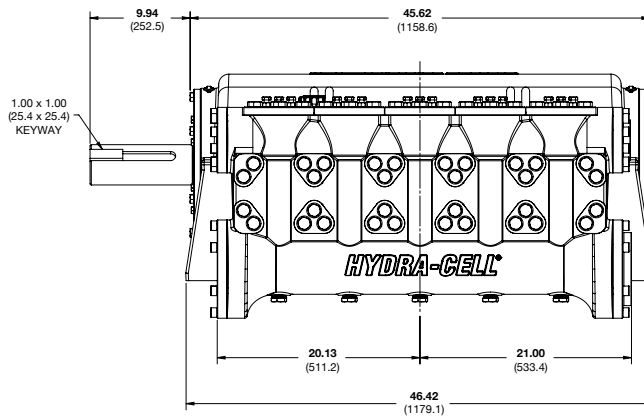

Side View

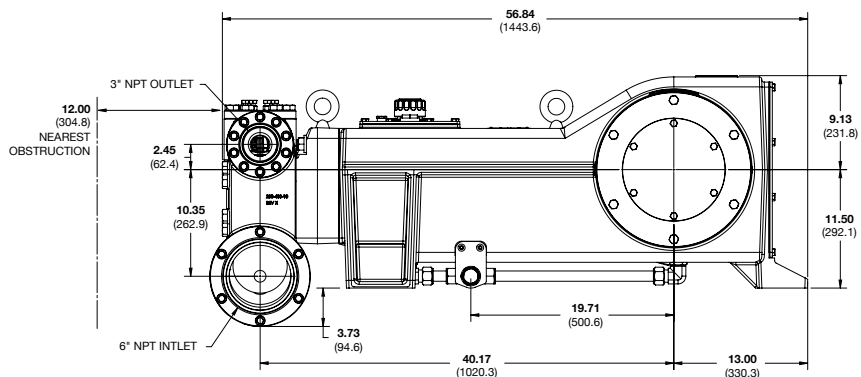

*Contact factory for obstruction distances closer than 12 inches (304.8 mm).

Bottom View

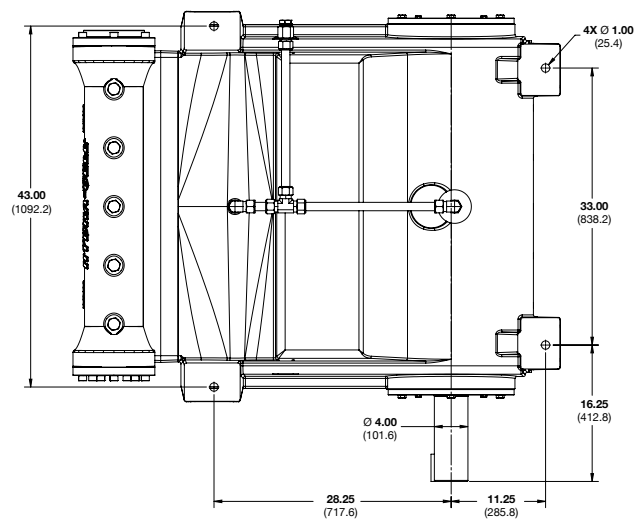

Note: Dimensions are for reference only. Contact factory for certified drawings.

Q330 High Pressure **How to Order**

Ordering Information

1	2	3	4	5	6	7	8	9	10	11	12	13	14
Q	3	3	0			D					T		

A complete Q330 Series High Pressure Model Number contains 14 digits including 8 customer-specified design and materials options, for example: Q330QRDGTTTA.

High Pressure

Digit	Order Code	Description
1-4	Q330	Pump Configuration Shaft-driven
5	P	Performance Max. 117 gpm (442 l/min) 4011 BPD @ 4000 psi (276 bar)
	Q	Max. 104 gpm (393 l/min) 3566 BPD @ 4500 psi (310 bar)
6	A	Pump Head Version NPT Ports (Steel)
	C	Weld Neck (Steel)
	D	Weld Neck (316L Stainless Steel)
	E	Weld Neck (Hastelloy C)
	F	Weld Neck (Duplex Alloy 2205 Stainless Steel)
	G	ANSI Flanged Ports (Duplex Alloy 2205 Stainless Steel)
	T	ANSI Flanged Ports (Hastelloy C)
7	D	Pump Head Material Nickel Aluminum Bronze (NAB)
8	G	Diaphragm & O-ring Material FKM
	T	Buna-N
9	H	Valve Seat Material 17-4 Stainless Steel
	N	Nitronic 50
	T	Hastelloy C
10	F	Valve Material 17-4 Stainless Steel
	N	Nitronic 50
	T	Hastelloy C
11	E	Valve Springs Elgiloy
	T	Hastelloy C
12	T	Valve Spring Retainers / Valve Guide Hastelloy C / PVDF

Digit	Order Code	Description
13	A	Hydra-Oil 10W30 standard-duty oil
	B	40-wt. oil
	H	15W50 high-temp severe-duty synthetic oil
14	C	Oil Level Monitor Cover Float switch, normally closed (recommended)
	O	Float switch, normally open
	Y	No switch, flat back cover



Hydra-Cell® Metering Solutions Pump Selection



MT8 Page 168



PI00 Page 171



P200 Page 173

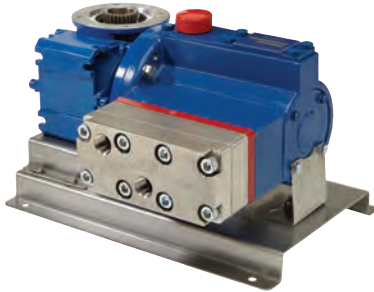

P300 Page 175



P400 Page 177



P500 Page 179

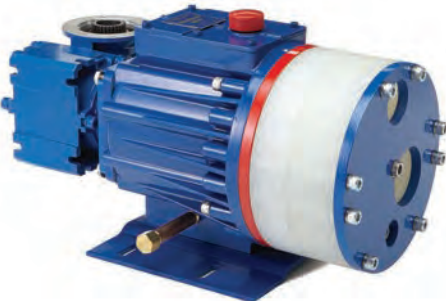

P600 Page 181

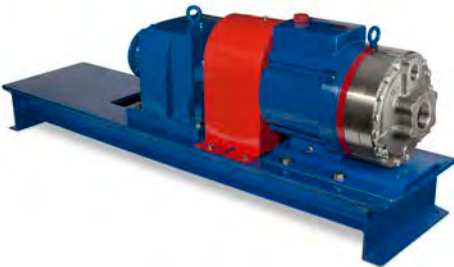

P700 Page 183

Hydra-Cell® Flow Capacities and Pressure Ratings

Maximum Flow Rates (gph) with 1800 rpm Motor Speed

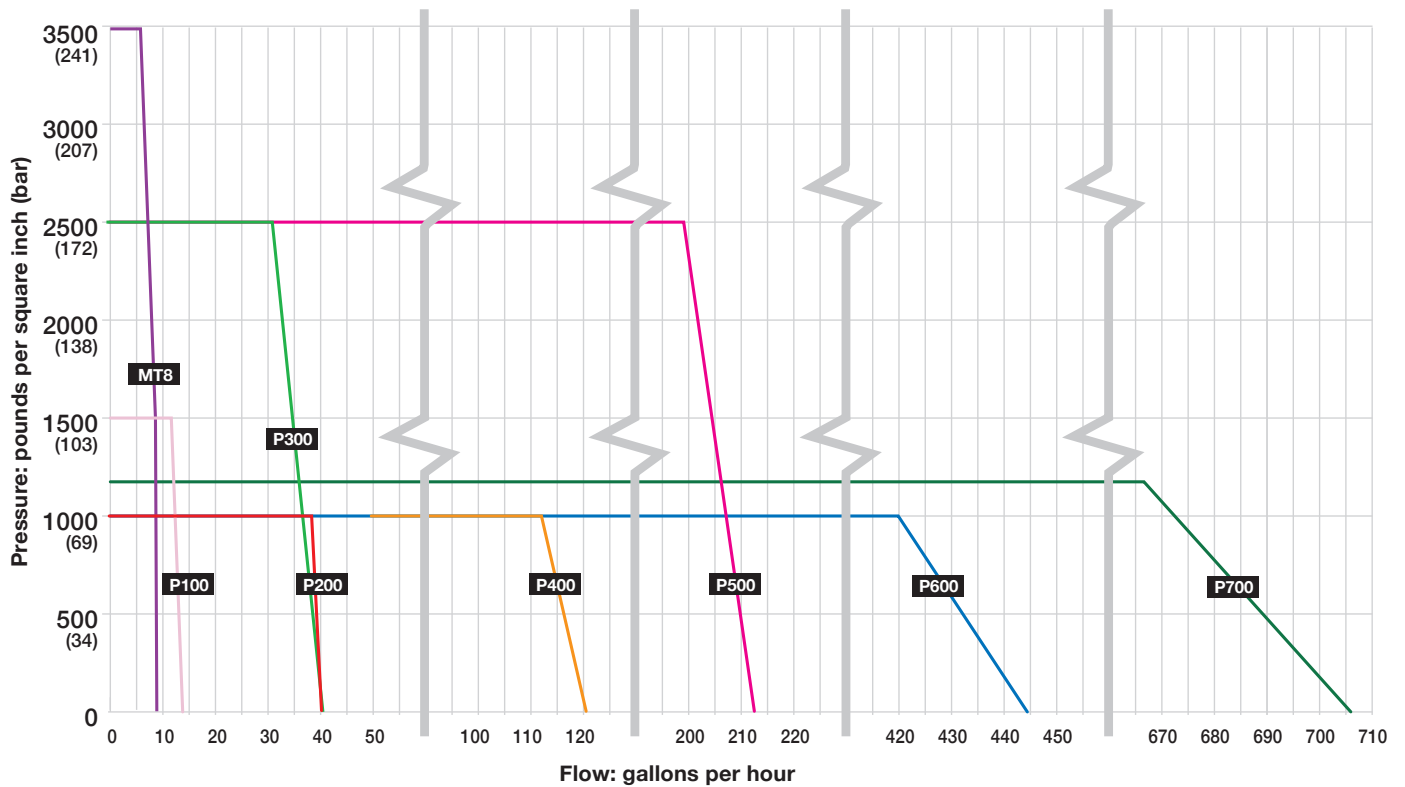

Flows shown in the graph above and listed in the chart below for each metering pump are based upon lab testing of multiple pumps. However, flows listed are approximate values and pumps must be calibrated once installed into any system. Flow variations will occur, but calibration will ensure proper pump performance.

Specifications for 1800 & 3600 rpm Motor Speed

Model ¹	Motor Speed rpm	Max Capacity gph	Max Discharge Pressure psi (bar)		Max Operating Temperature F (C) ³		Max Inlet Pressure psi (bar)
			Non-metallic ²	Metallic	Non-metallic	Metallic	
MT8	1800	8.0	350 (24)	3500 (241)	140° (60°)	250° (121°)	500 (34) ⁴
P100	1800	13.5	350 (24)	1500 (103)	140° (60°)	250° (121°)	250 (17)
P100	3600	27.0	350 (24)	1500 (103)	140° (60°)	250° (121°)	250 (17)
P200	1800	40.5	350 (24)	1000 (69)	140° (60°)	250° (121°)	250 (17)
P200	3600	81.0	350 (24)	1000 (69)	140° (60°)	250° (121°)	250 (17)
P300	1800	40.6	N/A	2500 (172)	N/A	250° (121°)	500 (34)
P300	3600	81.4	N/A	2500 (172)	N/A	250° (121°)	500 (34)
P400	1800	121.1	350 (24)	1000 (69)	140° (60°)	250° (121°)	250 (17)
P400	3600	242.8	350 (24)	1000 (69)	140° (60°)	250° (121°)	250 (17)
P500	1800	212.8	N/A	2500 (172)	N/A	250° (121°)	500 (34)
P500	3600	425.9	N/A	2500 (172)	N/A	250° (121°)	500 (34)
P600	1800	444.8	350 (24)	1000 (69)	140° (60°)	250° (121°)	250 (17)
P600	3600	890.3	350 (24)	1000 (69)	140° (60°)	250° (121°)	250 (17)
P700	1800	706	N/A	1200 (83)	N/A	250° (121°)	250 (17)
P700	3600	1394	N/A	1200 (83)	N/A	250° (121°)	250 (17)

¹ Ratings are for X-cam design.

² 350 psi (24 bar) maximum with PVDF or PVC (MT8 only) liquid ends; 250 psi (17 bar) maximum with Polypropylene liquid end (P Series only).

³ Consult factory for correct component selection for temperatures from 160°F (71°C) to 250°F (121°C).

⁴ 300 psi (20 bar) maximum with non-metallic MT8 models.

Hydra-Cell® Metering Pumps Design Advantages

Accurate, Reliable Electronic Flow Control

Unlike metering pumps that use manual stroke adjusters, Hydra-Cell P Series metering pumps use Variable Frequency Drive (VFD) electronic flow adjustment to maintain greater accuracy over the entire turndown range. This reduces the possibility of operator error, pumping inaccuracies, lost motion, and chance of leakage.

- Solid-state electronics are unlikely to fail.
- Metering is linear over the entire range.
- Volume per stroke is constant and a known value.
- Easy calibration of the desired feed rate.
- Rate of change is virtually instantaneous (0 to maximum rpm in 0.3 seconds) with AC motor.

Greater Choice of Materials Enhances Capability



Some metering pump manufacturers offer only PTFE diaphragms, which require more frequent and costly replacement due to stress and low processing temperatures. Hydra-Cell metering pumps can be equipped with a variety of diaphragm materials (FKM, Buna-N, EPDM, Neoprene, Aflas, FFKM and PTFE). This enables Hydra-Cell metering pumps to operate over a wider range of processing applications.

In addition, several Hydra-Cell metering pump packages are available with special materials such as Hastelloy C and PVDF. Other metering pumps apply substantial price adders for exotic liquid end materials.

Mesamoll Oil

Mesamoll oil offers outstanding gelling capacity and high saponification resistance along with good dielectric properties and resistance to weathering and light. It is ideal for use with many types of polymers and in instances where it will come into contact with water or an alkali. For information about ordering Hydra-Cell pumps with Mesamoll Oil, contact the factory.

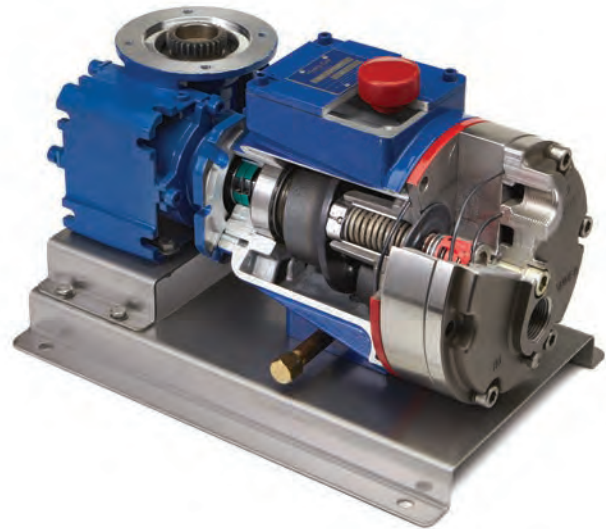

Achieve Economy through Technology

- Smaller footprint with the same capability as larger pumps lowers acquisition costs and saves valuable space in the facility.
- Each model covers an extensive range of pressures and flows - no need for different plunger and liquid end sizes to accommodate increases.
- Inherent simplicity of the Hydra-Cell design allows versatile application compared to complex metering pumps that may require expensive construction changes to meet specific needs.
- A replenishment valve in every piston assembly ensures optimum actuating oil on every stroke for continuous accuracy.
- Lower parts and maintenance costs.
- Separate gearbox makes it easy to change applications while preventing cross-contamination of actuating oil.
- Multiplexing capability enables mixing ratios of multiple fluids in flexible, economical ways.

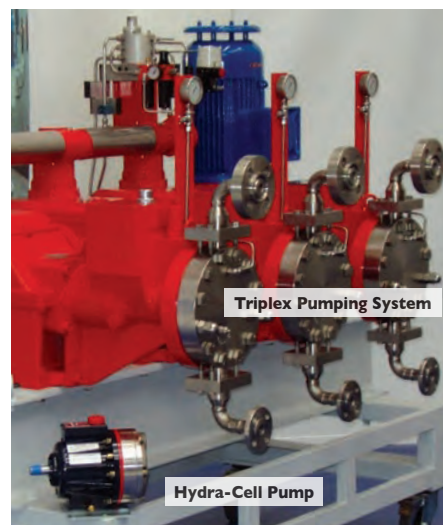

Pumps Shown to Scale

Both the Hydra-Cell pump and triplex metering pump shown are rated for 396 gph (1500 lph) @ 1160 psi (80 bar). The smaller footprint of Hydra-Cell equates to less expensive maintenance and reduced cost of spares.

Hydra-Cell® Metering Pumps Design Advantages

Accurate Metering and Dosing with Virtually Pulse-less Flow

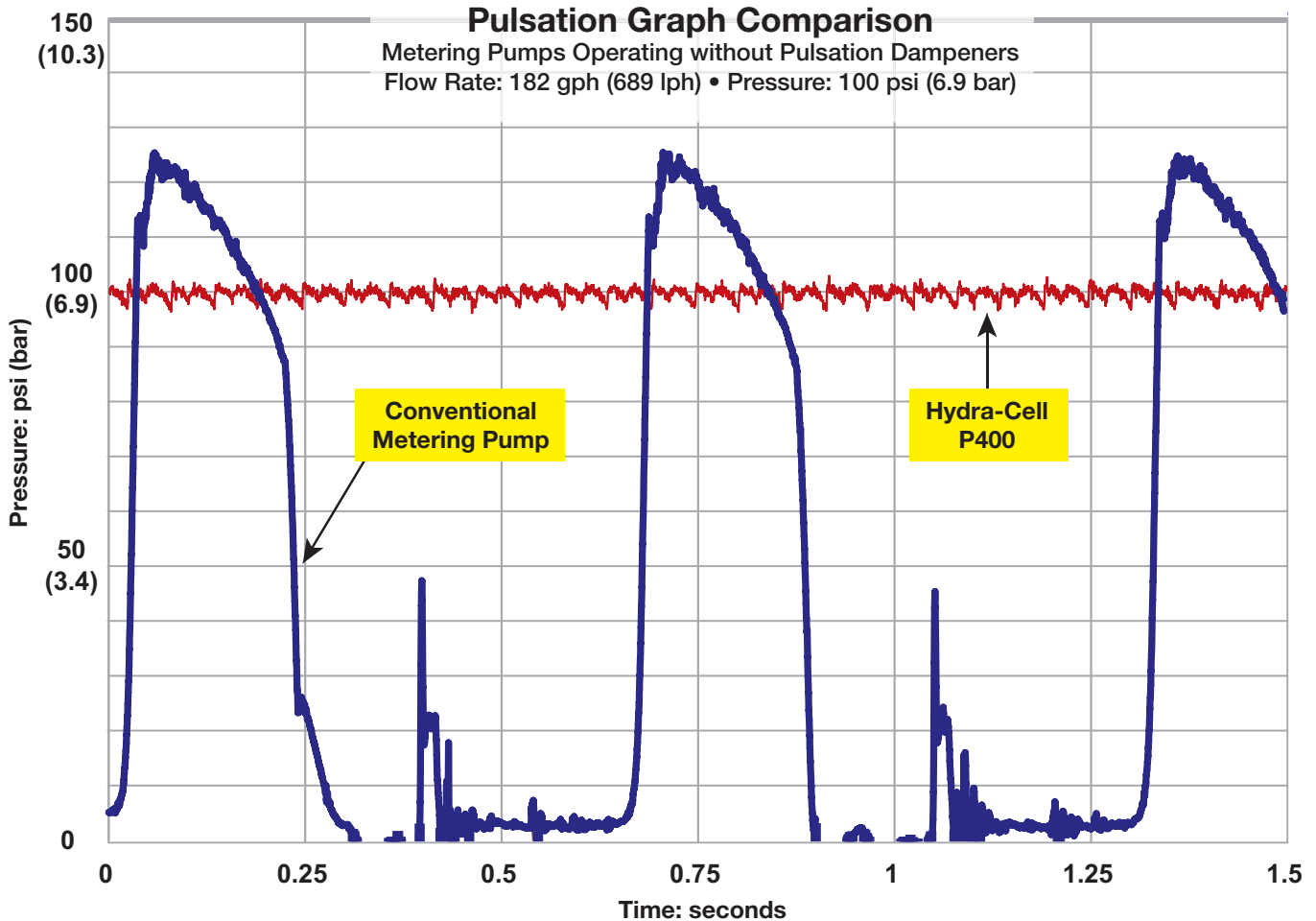

Compared to conventional metering pumps operating under the same conditions at the same flow and pressure, Hydra-Cell metering pumps provide smooth, almost pulse-less performance.

This allows for the design of a safer, less expensive metering pump system that can be used in more accurate applications, such as spraying, which cannot tolerate pulsing flow.

Reduced Pulsations Improve Operation

Pulsing, surging flow from traditional metering pumps can produce greater strain on the system and more wear and tear on the pump. Hydra-Cell features a multiple-diaphragm design (except model P100) that practically eliminates pulsations.

- Reduces pipe strain.
- Enhances operating safety.
- Minimizes maintenance.
- Reduces friction and acceleration losses in the suction line.
- Eliminates the need for pulsation dampeners.
- Provides accurate metering with linear, constant flow.
- Lowers system acquisition costs.



The multiple-diaphragm design of Hydra-Cell metering pumps provides linear, virtually pulse-less flow without the need for expensive pulsation dampeners.

Hydra-Cell® Metering Performance Standards

P Series Pumps Exceed API 675 Performance Standards

In 1994, the American Petroleum Institute (API) adapted its Standard 675 to stipulate performance characteristics for controlled-volume, positive displacement pumps. Although revised in 2010, and again in 2012, API 675 primarily defined metering pumps using mechanical stroke adjustment.

Hydra-Cell Metering Solutions meet or exceed API 675 performance standards by using electronic flow control to improve accuracy and a multiple-diaphragm design to reduce pulsations. Used in precise metering, dosing, injection, and mixing applications, Hydra-Cell pumps provide an economical alternative to conventional metering pumps.

Operational Data for Testing

Pump Configuration:	P300NRGSS015S
Reducer:	15:1
Pressure:	1500 psi
Actuating Oil:	10W-30 Hydra-Oil
Ambient Temperature:	71.5°F
Pumped Fluid:	Water @72°F
Gravity Feed:	1-to-3 Feet Positive Head
Franklin IMDS Motor:	240-2400 rpm 1 hp

Accuracy - Performance at a Set Point

For continuous metering applications, Hydra-Cell P Series pumps provide precise steady-state accuracy of $\pm 1\%$ or better.

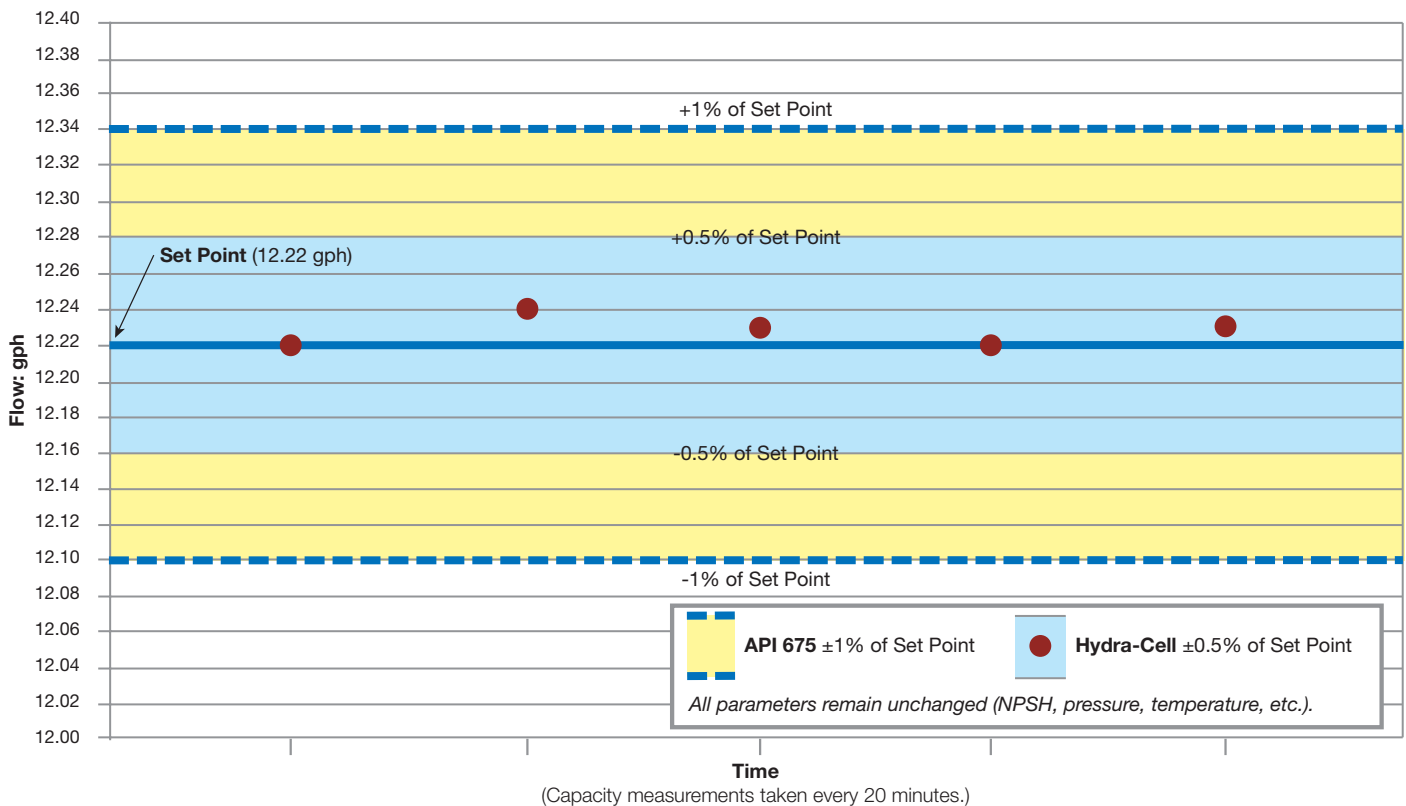

Linearity - Speed/Flow Rate Relationship

For smooth, virtually pulse-less performance, Hydra-Cell P Series pumps provide linear flow within $\pm 3\%$ or better.

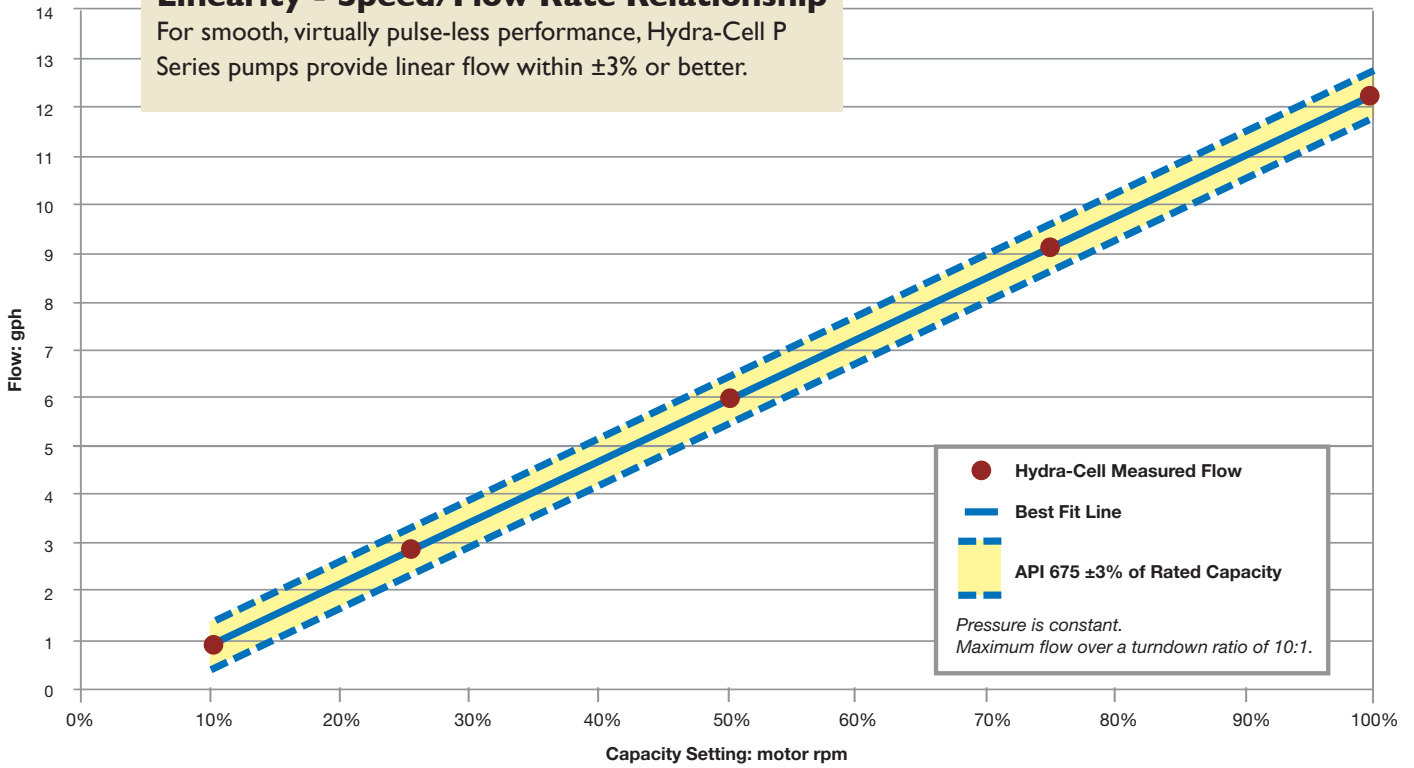

Best Fit Line is drawn through the Measured Flow data points, taken at 100%, 75%, 50%, 25%, and 10% of Rated Capacity (12.25 gph).

Repeatability - Return to Set Conditions

Hydra-Cell P Series pumps always return to $\pm 3\%$ or better of a set point condition after deviation (1200 rpm tested below).

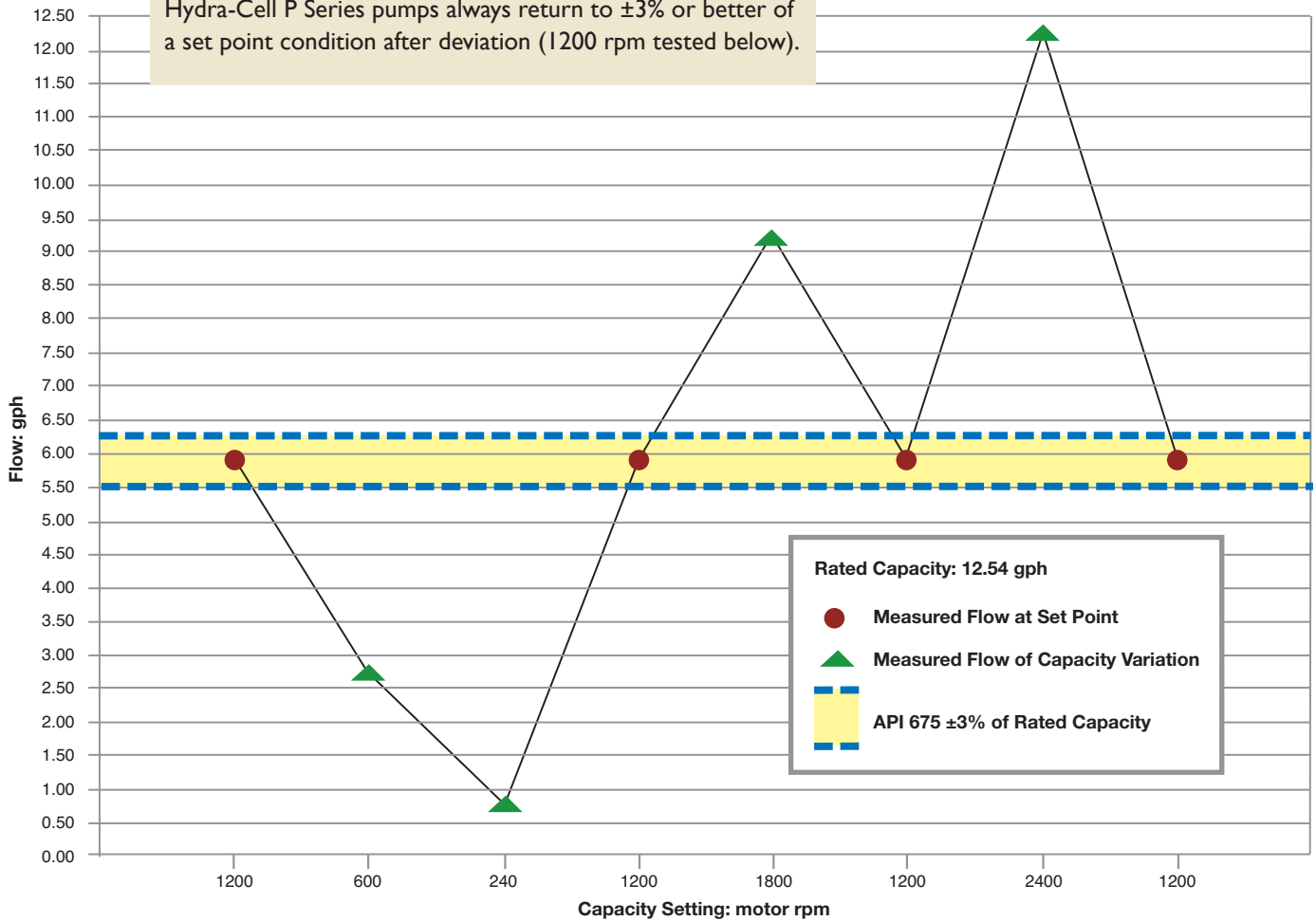

MT8 Pump

Maximum Flow Rate: 8.00 gph (30.28 lph)
Minimum Flow Rate: 0.06 gph (0.227 lph)
Maximum Pressure: 3500 psi (241 bar) for Metallic Pump Heads
350 psi (24 bar) for Non-metallic Pump Heads

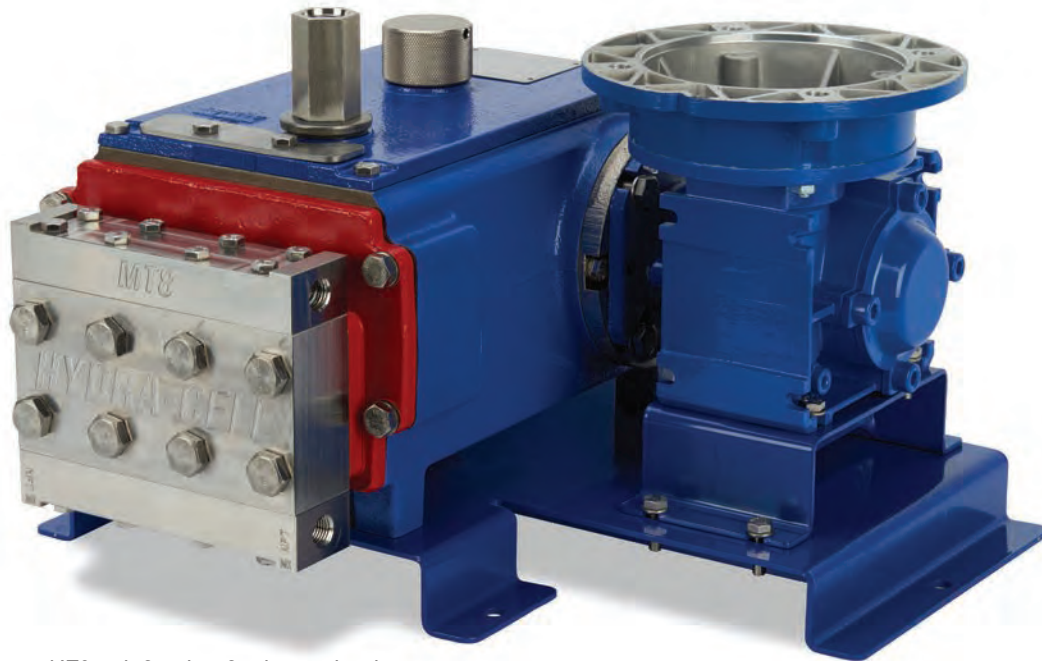

MT8 with Stainless Steel pump head.

Delivers Linear, “Pulse-free” Flow at Low-to-High Pressures

This groundbreaking metering pump is the latest addition to the Hydra-Cell Metering Solutions product line. It features a triplex-diaphragm design to provide linear, virtually pulse-free flow without the need for expensive pulsation dampeners.

The MT8 exceeds API 675 Performance Standards for Steady-State Accuracy ($\pm 1\%$), Linearity ($\pm 3\%$) and Repeatability ($\pm 3\%$).

Hydraulically-balanced and actuated, the pump features an integral relief to protect the pump from over-pressurization on the discharge side. Easy-to-replace cartridge check valves have double-sealing surfaces.

The MT8 patented overfill/underfill valve system ensures optimum actuating oil on every stroke for continuous accuracy and protects the pump and diaphragms.

Pump Data

Diaphragms per Liquid End	3
Flow Control	Electronic variable speed drive
Maximum Discharge Pressure	
Metallic Heads:	3500 psi (241 bar)
Non-metallic Heads:	350 psi (24 bar)
Maximum Inlet Pressure	
Metallic Heads:	500 psi (34 bar)
Non-metallic Heads:	300 psi (20 bar)
Operating Temperatures (min./max.)	
Metallic Heads:	40 F (4.4 C) to 250 F (121 C)
Non-metallic Heads:	40 F (4.4 C) to 140 F (60 C)
<i>Consult factory for temperatures outside this range</i>	
Inlet Port	1/4 inch NPT or BSPT
Discharge Port	1/4 inch NPT or BSPT Maximum
Maximum Solids Size	200 microns
Suction Lift Capability	20 feet (6.1 meters)
Shaft Rotation	Bi-directional
Oil Capacity	1.75 US quarts (1.7 liters)
Weight (less motor)	
Metallic Heads:	100 lbs. (45 kg)
Non-metallic Heads:	75 lbs. (34 kg)

MT8 Pump Performance

Maximum Flow at Designated Pressure for Pumps with Electronic Gearbox Reducers

All Pumps in Gallons per Hour (gph)					Pump rpm	Gear Ratio	Motor rpm
350 psi	500 psi	1500 psi	2500 psi	3500 psi			
0.479	0.473	0.429	0.387	0.349	18	100:1	1800
0.593	0.587	0.532	0.479	0.428	22.5	80:1	
0.784	0.776	0.703	0.635	0.567	30	60:1	
0.972	0.961	0.872	0.795	0.714	36	50:1	
1.189	1.177	1.089	0.985	0.888	45	40:1	
1.609	1.593	1.437	1.309	1.176	60	30:1	
2.336	2.312	2.105	1.924	1.727	90	20:1	
4.706	4.657	4.257	3.839	3.430	180	10:1	
6.218	6.156	5.556	5.064	4.464	240	7.5:1	
8.000*	8.000*	8.000*	7.320*	6.530*	360	5:1	

Required Motor hp

1/2

* Flow rates above 8 gph are not guaranteed to meet API 675 Performance Standards; therefore, pump rpm should be limited to 315 at 350 psi and 352 at 1500 psi when using a 5:1 gear reducer and 1800 rpm motor. To reach 8 gph at pressures above 1700 psi with the same reducer and motor, the VFD will need to be programmed for operation above 60 Hz.

Maximum Flow at Designated Pressure for Pumps with Manual Variable Speed Gearbox

Flow Rates in Gallons per Hour (gph)

Manual Dial Setting	All Pumps 350 psi		Metallic Pump Heads Only								Motor rpm
	Flow Rate	rpm	500 psi		1500 psi		2500 psi		3500 psi		
	Flow Rate	rpm	Flow Rate	rpm	Flow Rate	rpm	Flow Rate	rpm	Flow Rate	rpm	
1	1.85	70	1.85	71	1.62	70	1.44	70	1.28	70	1800
2	3.67	144	3.64	144	3.26	143	2.92	143	2.62	143	
3	5.56	213	5.51	214	4.90	213	4.40	212	3.93	211	
4	7.26	280	7.16	281	6.36	278	5.70	278	5.09	277	
5					7.75	343	6.94	342	6.17	341	
6									7.08	405	

Manual Dial Setting to achieve Maximum Flow Rate at pressures shown above

Manual Dial Setting to achieve Maximum Flow Rate at pressures shown above										Motor rpm
4.45		4.50		5.17		5.87		6.90		
8.00	310	8.00	315	8.00	354	8.00	399	8.00	462	1800

Required Motor hp

1/2

- Minimum flow rate of 0.06 gph (0.227 lph) can be achieved at a Manual Dial Setting of 0.1.
- Flow rates above 8 gph (30.28 lph) are not guaranteed to meet API 675 Performance Standards.
- Only use motors with turndown ratios to match the appropriate range of applications.

Please Note:

Systems vary. The MT8 pump must be calibrated once installed to ensure optimum performance. The API 675 Performance Standard is achievable for flow rates as low as 0.06 gph (or 0.227 lph). Please contact the factory for assistance.

How to Order

A complete pump order number contains 16 digits based on the specified pump materials listed below.

1 M	2 T	3	4	5	6	7	8 J	9 N	10	11	12	13	14	15	16
---------------	---------------	---	---	---	---	---	---------------	---------------	----	----	----	----	----	----	----

Pump Model Size (Digits 1-2)

MT Triplex Metering Pumps

Pump Capacity (Digits 3-4)

08 0.06 - 8.00 gph (0.227 - 30.28 lph)

8D MT8 Duplex 0.06 - 8.00 gph (0.227 - 30.28 lph) per pump

Pump Version (Digit 5)

N NPT Ports

M BSPT Ports

Pump Head (Digits 6-7)

SN 316 SST

TN Hastelloy C

AN Alloy 20

VN PVC

MN PVDF

Diaphragm (Digit 8)

J PTFE

K PTFE with FKM O-rings

Leak Detection Style (Digit 9)

N No leak detection

CV Ball/Seat (Digits 10-11)

SS 316 SST / 316 SST

TT Hastelloy C / Hastelloy C

AA Alloy 20 / Alloy 20

Hydraulic End Oil (Digit 12)

G 5W30 (Synthetic oil)

K Food-contact oil

Motor Flange Size (Digit 13)

A NEMA 56C

B NEMA 143/145TC

C IEC 63 B5

D IEC 71 B5

E IEC 80 B5

H NEMA 56C (MA only)

M IEC 80 B14 (MA or MX only)

X No motor flange

Gearbox Ratio (Digits 14-15)

00 100:1

80 80:1

60 60:1

50 50:1

40 40:1

30 30:1

20 20:1

10 10:1

07 7.5:1

05 5:1

MA Manual adjustment
(specify H or M flange for this option)

MX Manual adjustment ATEX
(specify M flange for this option)

XX No gearbox

Baseplate (Digit 16)

C Carbon Steel (Epoxy painted)

S SST

M Carbon Steel (Epoxy painted) Manual adjustment

T SST Manual adjustment

X No baseplate

Representative Drawings Inches (mm)

Note: Dimensions are for reference only. Contact factory for certified drawings.

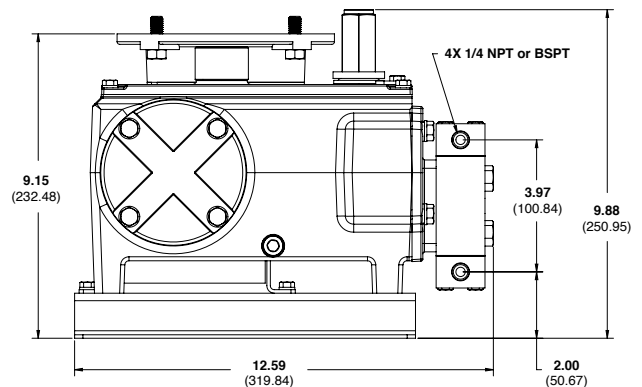
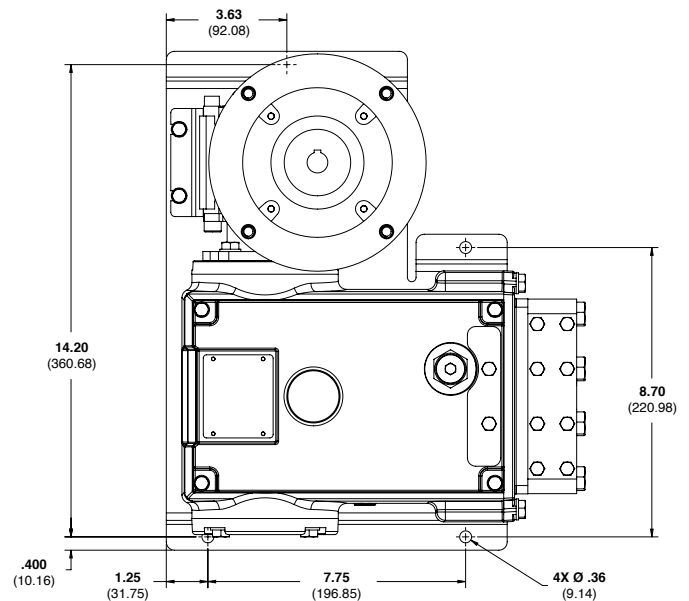

Metallic Pump Heads

For accessories, options, and a system installation example, see page 185.

PI00 Series

Maximum Flow Rate: 27.0 gph

Maximum Pressure: 1500 psi (103 bar) for Metallic Pump Heads
350 psi (24 bar) for Non-metallic Pump Heads

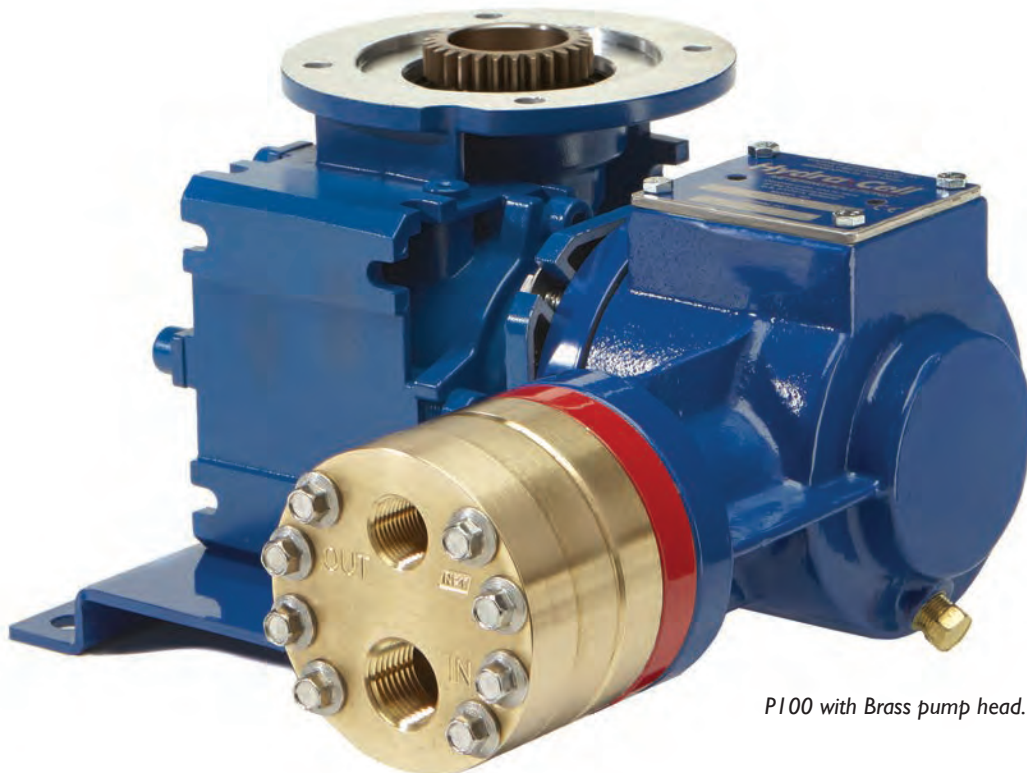

PI00 with Brass pump head.

Performance* Maximum Flow at Designated Pressure

All Pumps (gph)		Metallic Pump Heads Only (gph)			Pump rpm	Gear Ratio	Motor rpm
100 psi	250 psi	500 psi	1000 psi	1500 psi			
1.086	1.077	1.058	1.015	0.981	30	60:1	1800
1.316	1.300	1.273	1.220	1.184	36	50:1	
1.630	1.628	1.607	1.535	1.492	45	40:1	
2.192	2.182	2.148	2.056	2.000	60	30:1	
2.643	2.626	2.582	2.473	2.405	72	25:1	
3.318	3.291	3.232	3.099	3.014	90	20:1	
4.444	4.400	4.316	4.141	4.028	120	15:1	
6.695	6.618	6.483	6.226	6.057	180	10:1	
8.947	8.836	8.651	8.311	8.085	240	7.5:1	
13.45	13.27	12.99	12.48	12.14	360	5:1	
17.95	17.71	17.32	16.65	16.20	480	7.5:1	3600
26.96	26.58	25.99	24.99	24.31	720	5:1	

* Capacity data is shown for pumps with elastomeric diaphragms. Consult factory for performance characteristics of pumps with PTFE diaphragms.

Required Motor hp

1/2	3/4	1
-----	-----	---

Pump Data

Diaphragms per Liquid End	1
Flow Control	Electronic variable speed drive
Maximum Discharge Pressure	
Metallic Heads:	1500 psi (103 bar)
Non-metallic Heads:	PVDF- 350 psi (24 bar) Polypropylene- 250 psi (17 bar)
Maximum Inlet Pressure	250 psi (17 bar)
Maximum Operating Temperature	
Metallic Heads:	250° F (121° C)*
Non-metallic Heads:	140° F (60° C)
Inlet Port	1/2 inch NPT or BSPT
Discharge Port	3/8 inch NPT or BSPT
Weight (less motor)	
Metallic Heads:	21.3 lbs (9.7 kg)
Non-metallic Heads:	19.2 lbs (8.7 kg)
Dimensions (less motor)**	
Metallic Heads:	9.93" W x 11.36" D x 6.92" H (252.2 mm W x 287.4 mm D x 175.8 mm H)
Non-metallic Heads:	9.93" W x 11.61" D x 6.92" H (252.2 mm W x 294.9 mm D x 175.8 mm H)

* Consult factory for correct component selection for temperatures from 160° F (71° C) to 250° F (121° C).

** For (NEMA) 56C motor frame only.

Representative Drawings Inches (mm)

Note: Dimensions are for reference only. Contact factory for certified drawings.

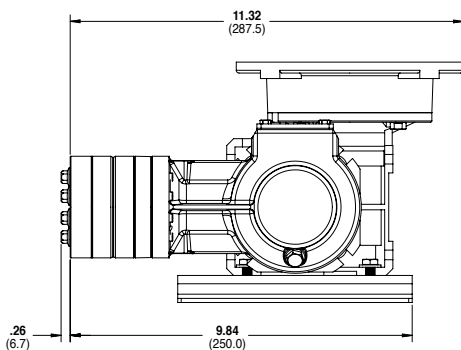
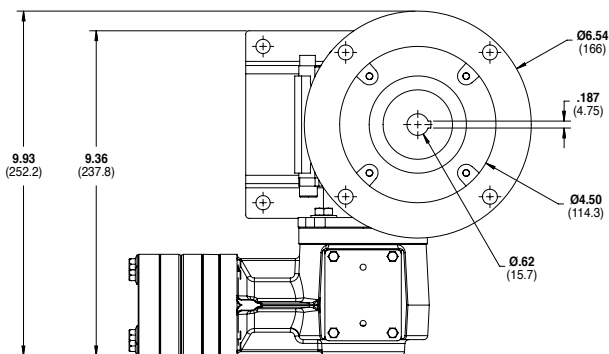

Metallic Pump Heads (NEMA 56C)

For accessories, options, and a system installation example, see page 185.

How to Order

A complete pump order number contains 13 digits based on the specified pump materials listed below.

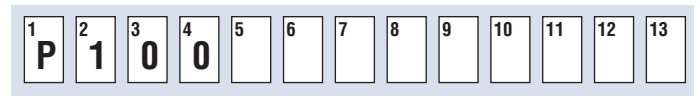

Pump Model Size (Digits 1-4)

P100 For all P100 Pumps (Non Kel-Cell)

Pump Version (Digit 5)

N NPT Ports (NEMA motors only)
M BSPT Ports (IEC motors only)

Pump Head / Retainer Material (Digit 6)

B Brass / Hastelloy C
M PVDF / PVDF
P Polypropylene / Polypropylene
S 316L Stainless Steel / Hastelloy C
T Hastelloy C / Hastelloy C

Diaphragm & O-ring Material / Oil (Digit 7)▲

A Atlas / PTFE O-ring (Synthetic oil)
E EPDM (EPDM-compatible oil)
X FKM (Synthetic oil)
J PTFE (Food-contact oil)
P Neoprene (Synthetic oil)
T Buna-N (Synthetic oil)

▲ See price list for different actuating oils available with these materials.

Check Valve Material (Digits 8-9)

(Valve Spring / Valve Seat / Valve)

SS Elgiloy / 316L SST / Nitronic 50
TT Hastelloy C / Hastelloy C / Hastelloy C
SC Elgiloy / Ceramic / Ceramic
TC Hastelloy C / Ceramic / Ceramic

Gearbox Ratio (Digits 10-12) NEMA Motors

060 60:1 (56C Motor Frame)
050 50:1 (56C Motor Frame)
040 40:1 (56C Motor Frame)
030 30:1 (56C Motor Frame)
025 25:1 (56C Motor Frame)
020 20:1 (56C Motor Frame)
015 15:1 (56C Motor Frame)
010 10:1 (56C Motor Frame)
007 7.5:1 (56C Motor Frame)
005 5:1 (56C Motor Frame)
A05 5:1 (143/145TC Motor Frame)

Base Plate (Digit 13)

C Carbon Steel (Epoxy painted)
S 304 Stainless Steel

P200 Series

Maximum Flow Rate: 81.0 gph

Maximum Pressure: 1000 psi (69 bar) for Metallic Pump Heads
350 psi (24 bar) for Non-metallic Pump Heads



P200 with Polypropylene pump head.

Performance Maximum Flow at Designated Pressure

All Pumps (gph)		Metallic Pump Heads Only (gph)		Pump rpm	Gear Ratio	Motor rpm
100 psi	250 psi	500 psi	1000 psi			
3.378	3.321	3.249	3.128	30	60:1	1800
4.059	3.994	3.911	3.776	36	50:1	
5.072	5.015	4.908	4.748	45	40:1	
6.758	6.686	6.555	6.353	60	30:1	
8.107	8.022	7.873	7.637	72	25:1	
10.130	10.027	9.849	9.563	90	20:1	
13.503	13.369	13.14	12.77	120	15:1	
20.248	20.052	19.73	19.19	180	10:1	
26.993	26.735	26.32	25.62	240	7.5:1	
40.483	40.101	39.49	38.46	360	5:1	
53.97	53.47	52.66	51.30	480	7.5:1	3600
80.95	80.20	79.01	76.98	720	5:1	

Required Motor hp

1/4	1/2	3/4	1	1-1/2
-----	-----	-----	---	-------

Pump Data

Diaphragms per Liquid End	3
Flow Control	Electronic variable speed drive
Maximum Discharge Pressure	
Metallic Heads:	1000 psi (69 bar)
Non-metallic Heads:	PVDF- 350 psi (24 bar) Polypropylene- 250 psi (17 bar)
Maximum Inlet Pressure	250 psi (17 bar)
Maximum Operating Temperature	
Metallic Heads:	250 °F (121 °C)*
Non-metallic Heads:	140 °F (60 °C)
Inlet Port	1/2 inch NPT or BSPT
Discharge Port	3/8 inch NPT or BSPT
Weight (less motor)	
Metallic Heads:	41.8 lbs (19.0 kg)
Non-metallic Heads:	32.8 lbs (14.9 kg)
Dimensions (less motor)**	
Metallic Heads:	15.59" W x 11.68" D x 8.97" H (396.1 mm W x 296.7 mm D x 227.8 mm H)
Non-metallic Heads:	15.59" W x 12.06" D x 8.97" H (396.1 mm W x 306.3 mm D x 227.8 mm H)

* Consult factory for correct component selection for temperatures from 160° F (71° C) to 250° F (121° C).

** For (NEMA) 56C motor frame only. Consult factory for other motor frame sizes.

Representative Drawings Inches (mm)

Note: Dimensions are for reference only. Contact factory for certified drawings.

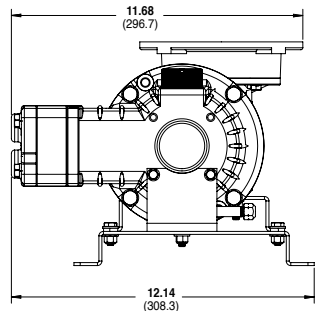
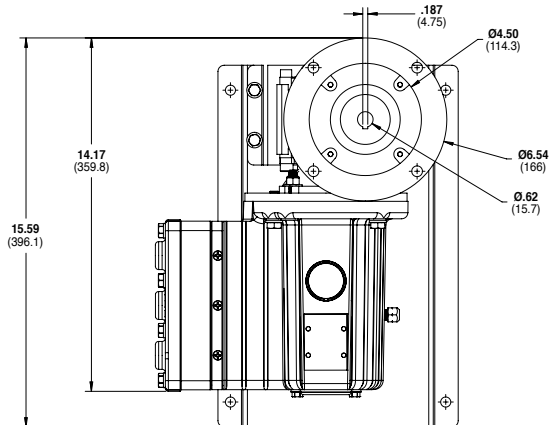

Metallic Pump Heads (NEMA 56C)

For accessories, options, and a system installation example, see page 185.

How to Order

A complete pump order number contains 13 digits based on the specified pump materials listed below.

1	2	3	4	5	6	7	8	9	10	11	12	13
P	2	0	0									

Pump Model Size (Digits 1-4)

P200 For all P200 Pumps (Non Kel-Cell)

Pump Version (Digit 5)

N NPT Ports (NEMA motors only)
M BSPT Ports (IEC motors only)

Pump Head / Retainer Material (Digit 6)

B Brass / Hastelloy C
M PVDF / PVDF
P Polypropylene / Polypropylene
S 316L Stainless Steel / Hastelloy C
T Hastelloy CW12MW / Hastelloy C

Diaphragm & O-ring Material / Oil (Digit 7)▲

A Aflas / PTFE O-rings (Synthetic oil)
M Aflas / PTFE O-rings & FKM drive case elastomers (Mesamoll oil)
E EPDM (EPDM-compatible oil)
X FKM (Synthetic oil)
J PTFE (Food-contact oil)
P Neoprene (Standard oil)
T Buna-N (Standard oil)

▲ See price list for different actuating oils available with these materials.

Check Valve Material (Digits 8-9)

(Valve Spring / Valve Seat / Valve)

SS Elgiloy / 316L SST / Nitronic 50
TT Hastelloy C / Hastelloy C / Hastelloy C
SC Elgiloy / Ceramic / Ceramic
TC Hastelloy C / Ceramic / Ceramic

Gearbox Ratio (Digits 10-12) NEMA Motors

060 60:1 (56C Motor Frame)
050 50:1 (56C Motor Frame)
040 40:1 (56C Motor Frame)
030 30:1 (56C Motor Frame)
025 25:1 (56C Motor Frame)
020 20:1 (56C Motor Frame)
015 15:1 (56C Motor Frame)
010 10:1 (56C Motor Frame)
007 7.5:1 (56C Motor Frame)
005 5:1 (56C Motor Frame)
A05 5:1 (143/145TC Motor Frame)

Base Plate (Digit 13)

C Carbon Steel (Epoxy painted)
S 304 Stainless Steel

P300 Series

Maximum Flow Rate: 81.4 gph

Maximum Pressure: 2500 psi (172 bar) for Metallic Pump Heads

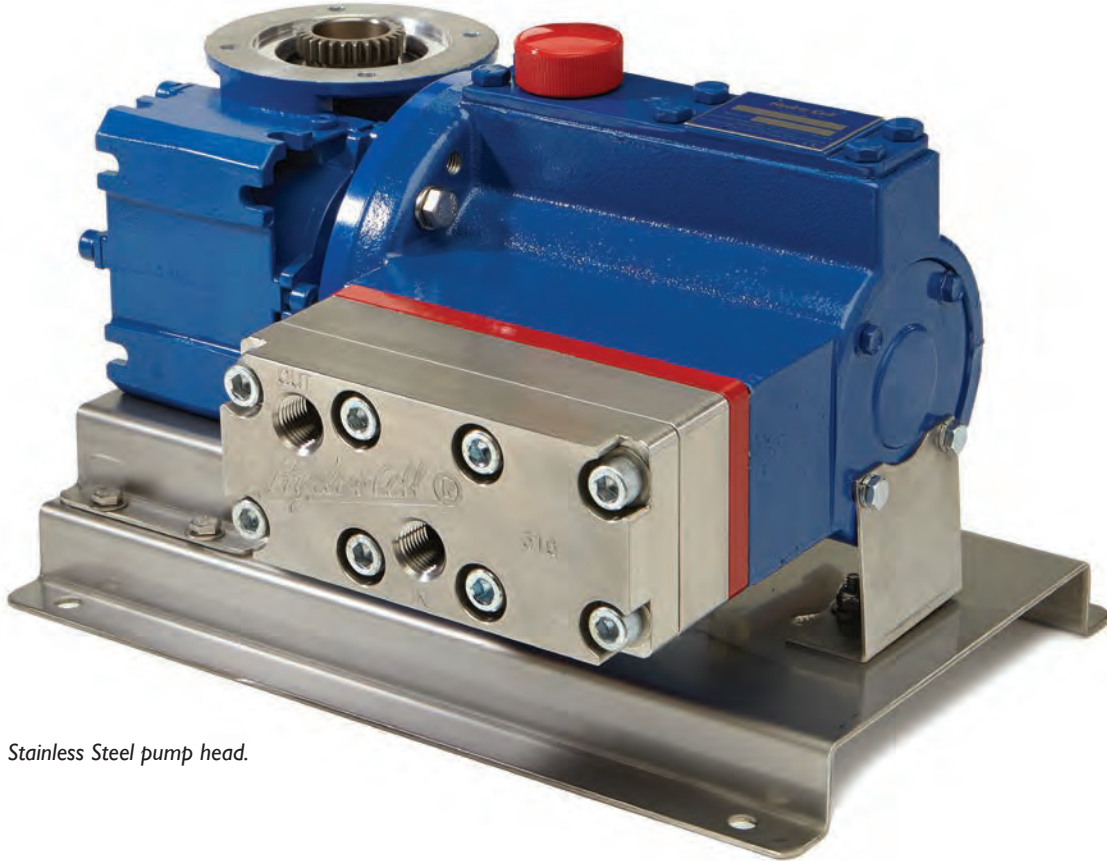

P300 with Stainless Steel pump head.

Performance Maximum Flow at Designated Pressure

100 psi	Metallic Pump Heads Only (gph)			Pump rpm	Gear Ratio	Motor rpm
	500 psi	1500 psi	2500 psi			
3.221	3.183	3.014	2.741	30	60:1	1800
3.895	3.849	3.655	3.350	36	50:1	
4.939	4.882	4.607	4.272	45	40:1	
6.639	6.548	6.194	5.786	60	30:1	
7.999	7.881	7.463	6.998	72	25:1	
10.04	9.880	9.368	8.815	90	20:1	
13.44	13.21	12.54	11.84	120	15:1	
20.24	19.88	18.89	17.90	180	10:1	
27.03	26.54	25.24	23.96	240	7.5:1	
40.63	39.87	37.93	36.08	360	5:1	
54.23	53.20	50.63	48.19	480	7.5:1	3600
81.42	79.85	76.02		720	5:1	

Required Motor hp

1/4	1/2	3/4	1	1-1/2	2
-----	-----	-----	---	-------	---

Pump Data

Diaphragms per Liquid End	3
Flow Control	Electronic variable speed drive
Maximum Discharge Pressure	
Metallic Heads:	2500 psi (172 bar)
Maximum Inlet Pressure	500 psi (34 bar)
Maximum Operating Temperature	
Metallic Heads:	250° F (121° C)*
Inlet Port	1/2 inch NPT or BSPT
Discharge Port	1/2 inch NPT or BSPT
Weight (less motor)**	
Metallic Heads:	54.5 lbs (24.7 kg)
Dimensions (less motor)**	
Metallic Heads:	15.79" W x 12.25" D x 9.46" H (401.2 mm W x 311.0 mm D x 240.2 mm H)

* Consult factory for correct component selection for temperatures from 160° F (71° C) to 250° F (121° C).

** For (NEMA) 56C motor frame only. Consult factory for other motor frame sizes.

Representative Drawings Inches (mm)

Note: Dimensions are for reference only. Contact factory for certified drawings.

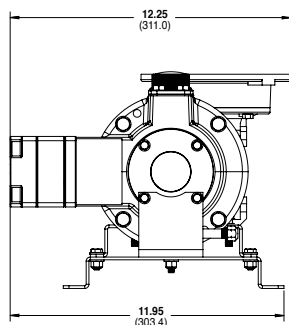
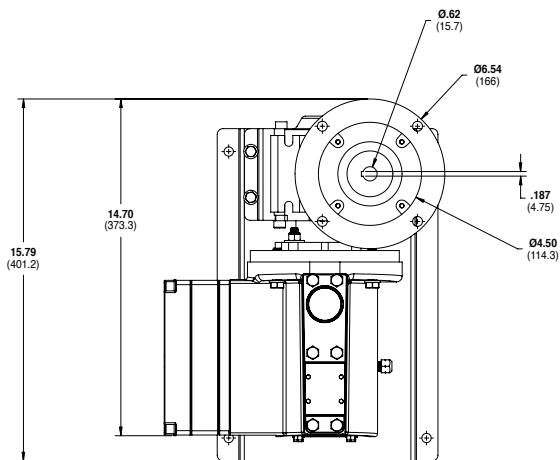

Metallic Pump Heads (NEMA 56C)

For accessories, options, and a system installation example, see page 185.

How to Order

A complete pump order number contains 13 digits based on the specified pump materials listed below.

1	2	3	4	5	6	7	8	9	10	11	12	13
P	3	0	0									

Pump Model Size (Digits 1-4)

P300 For all P300 Pumps (Non Kel-Cell)

Pump Version (Digit 5)

N NPT Ports (NEMA motors only)
M BSPT Ports (IEC motors only)

Pump Head / Retainer Material (Digit 6)

B Brass / Hastelloy C
R 304 Stainless Steel / Hastelloy C
S 316L Stainless Steel / Hastelloy C
T Hastelloy C / Hastelloy C

Diaphragm & O-ring Material / Oil (Digit 7)▲

E EPDM (EPDM-compatible oil)
X FKM (Synthetic oil)
J PTFE (Food-contact oil)
P Neoprene (Standard oil)
T Buna-N (Standard oil)

▲ See price list for different actuating oils available with these materials.

Check Valve Material (Digits 8-9)

(Valve Spring / Valve Seat / Valve)

SS Elgiloy / Nitronic 50 / Nitronic 50
TT Hastelloy C / Hastelloy C / Hastelloy C
SD Elgiloy / Tungsten Carbide / Tungsten Carbide
TD Hastelloy C / Tungsten Carbide / Tungsten Carbide

Gearbox Ratio (Digits 10-12) NEMA Motors

060 60:1 (56C Motor Frame)
050 50:1 (56C Motor Frame)
040 40:1 (56C Motor Frame)
030 30:1 (56C Motor Frame)
025 25:1 (56C Motor Frame)
020 20:1 (56C Motor Frame)
015 15:1 (56C Motor Frame)
010 10:1 (56C Motor Frame)
007 7.5:1 (56C Motor Frame)
A07 7.5:1 (143/145TC Motor Frame)
005 5:1 (56C Motor Frame)
A05 5:1 (143/145TC Motor Frame)

Base Plate (Digit 13)

C Carbon Steel (Epoxy painted)
S 304 Stainless Steel

P400 Series

Maximum Flow Rate: 242.8 gph

Maximum Pressure: 1000 psi (69 bar) for Metallic Pump Heads
350 psi (24 bar) for Non-metallic Pump Heads

Now Featuring Optimized Valve Plate for Improved Performance, Pump Safety & Reliability.

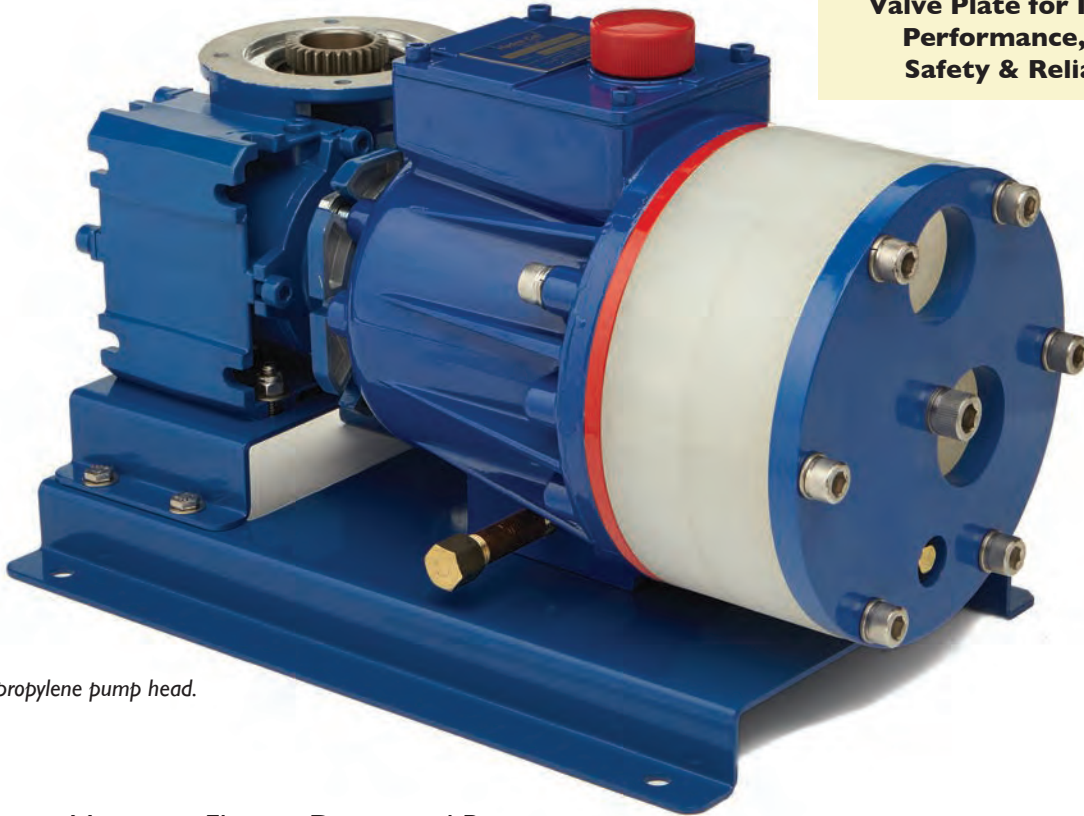

P400 with Polypropylene pump head.

Performance Maximum Flow at Designated Pressure

All Pumps (gph)		Metallic Pump Heads Only (gph)		Pump rpm	Gear Ratio	Motor rpm
100 psi	250 psi	500 psi	1000 psi			
9.637	9.280	8.491	6.464	30	60:1	1800
11.652	11.283	10.452	8.269	36	50:1	
14.66	14.30	13.37	11.21	45	40:1	
19.73	19.31	18.30	15.96	60	30:1	
23.79	23.32	22.24	19.75	72	25:1	
29.87	29.34	28.15	25.45	90	20:1	
40.011	39.375	38.00	34.94	120	15:1	
60.290	59.438	57.70	53.92	180	10:1	
80.569	79.501	77.41	72.90	240	7.5:1	
121.1	119.6	116.8	110.9	360	5:1	
161.69	159.75	156.22		480	7.5:1	3600
242.80	240.01			720	5:1	

Required Motor hp

1/4	1/2	3/4	1	1-1/2	2
-----	-----	-----	---	-------	---

Pump Data

Diaphragms per Liquid End	3
Flow Control	Electronic variable speed drive
Maximum Discharge Pressure	
Metallic Heads:	1000 psi (69 bar)
Non-metallic Heads:	PVDF- 350 psi (24 bar)
	Polypropylene- 250 psi (17 bar)
Maximum Inlet Pressure	250 psi (17 bar)
Maximum Operating Temperature	
Metallic Heads:	250° F (121° C)*
Non-metallic Heads:	140° F (60° C)
Inlet Port	1 inch NPT or BSPT
Discharge Port	3/4 inch NPT or BSPT
Weight (less motor)**	
Metallic Heads:	65.5 lbs (29.7 kg)
Non-metallic Heads:	52.5 lbs (23.8 kg)
Dimensions (less motor)**	
Metallic Heads:	9.94" W x 16.12" D x 10.29" H (252.4 mm W x 409.4 mm D x 261.3 mm H)
Non-metallic Heads:	9.94" W x 17.29" D x 10.29" H (252.4 mm W x 439.2 mm D x 261.3 mm H)

* Consult factory for correct component selection for temperatures from 160° F (71° C) to 250° F (121° C).

** For (NEMA) 56C motor frame only. Consult factory for other motor frame sizes.

Representative Drawings Inches (mm)

Note: Dimensions are for reference only. Contact factory for certified drawings.

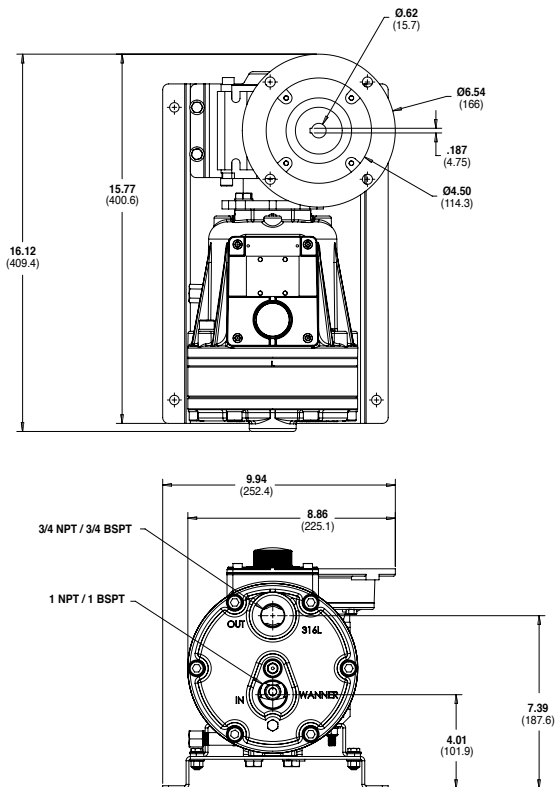

Metallic Pump Heads (NEMA 56C)

For accessories, options, and a system installation example, see page 185.

How to Order

A complete pump order number contains 13 digits based on the specified pump materials listed below.

1	2	3	4	5	6	7	8	9	10	11	12	13
P	4	0	0									

Pump Model Size (Digits 1-4)

P400 For all P400 Pumps (Kel-Cell with Optimized Valve Plate)

Pump Version (Digit 5)

N NPT Ports or ANSI Flanges (NEMA motors only)
M BSPT Ports or ANSI Flanges (IEC motors only)

Pump Head / Retainer Material (Digit 6)

B Brass / Hastelloy C
C Cast Iron / Hastelloy C
M PVDF / PVDF
P Polypropylene / Polypropylene
R 316L Stainless Steel (ANSI flange class 150 x 600) / Hastelloy C
S 316L Stainless Steel (NPT or BSPT) / Hastelloy C
T Hastelloy CW12MW / Hastelloy C

Diaphragm & O-ring Material / Oil (Digit 7)[▲]

A Atlas / PTFE O-rings (Synthetic oil)
E EPDM (EPDM-compatible oil)
X FKM (Synthetic oil)
J PTFE (Food-contact oil)
P Neoprene (Standard oil)
T Buna-N (Standard oil)

[▲] See price list for different actuating oils available with these materials.

Check Valve Material (Digits 8-9)

(Valve Spring / Valve Seat / Valve)

SS Elgiloy / 316L SST / Nitronic 50
TT Hastelloy C / Hastelloy C / Hastelloy C
SC Elgiloy / Ceramic / Ceramic
TC Hastelloy C / Ceramic / Ceramic
SD Elgiloy / Tungsten Carbide / Tungsten Carbide
TD Hastelloy C / Tungsten Carbide / Tungsten Carbide

Gearbox Ratio (Digits 10-12) NEMA Motors

060 60:1 (56C Motor Frame)
050 50:1 (56C Motor Frame)
040 40:1 (56C Motor Frame)
030 30:1 (56C Motor Frame)
025 25:1 (56C Motor Frame)
020 20:1 (56C Motor Frame)
015 15:1 (56C Motor Frame)
010 10:1 (56C Motor Frame)
007 7.5:1 (56C Motor Frame)
A07 7.5:1 (143/145TC Motor Frame)
005 5:1 (56C Motor Frame)
A05 5:1 (143/145TC Motor Frame)

Base Plate (Digit 13)

C Carbon Steel (Epoxy painted)
S 304 Stainless Steel

P500 Series

Maximum Flow Rate: 425.9 gph

Maximum Pressure: 2500 psi (172 bar) for Metallic Pump Heads

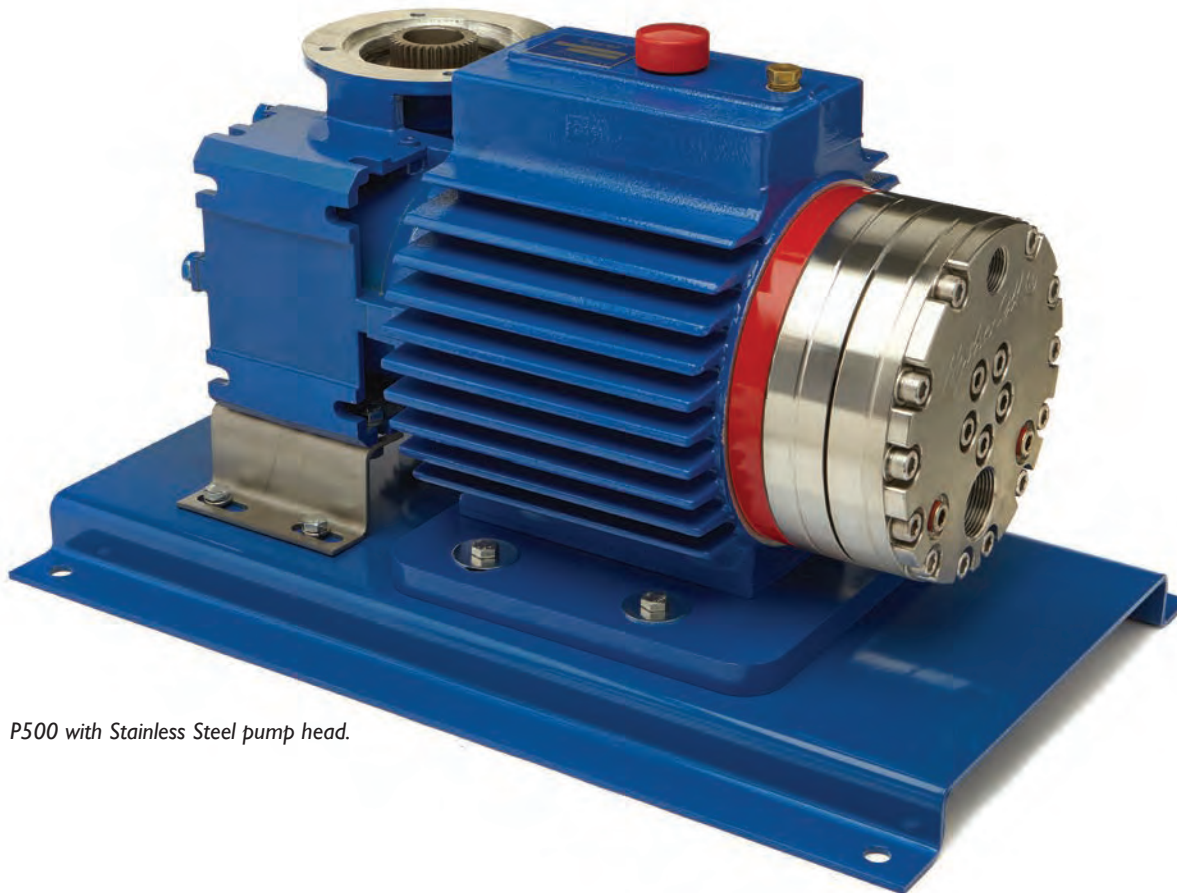

P500 with Stainless Steel pump head.

Performance Maximum Flow at Designated Pressure

100 psi	Metallic Pump Heads Only (gph)			Pump rpm	Gear Ratio	Motor rpm
	500 psi	1500 psi	2500 psi			
17.48	16.96	15.74	14.47	30	60:1	1800
20.97	20.43	19.11	17.71	36	50:1	
26.39	25.73	24.20	22.67	45	40:1	
35.27	34.47	32.63	30.80	60	30:1	
42.37	41.47	39.37	37.31	72	25:1	
53.03	51.97	49.49	47.07	90	20:1	
70.78	69.46	66.35	63.34	120	15:1	
106.3	104.4	100.1	95.88	180	10:1	
141.8	139.4	133.8	128.4	240	7.5:1	
212.8	209.4	201.2	193.5	360	5:1	
283.9	279.4	268.7	258.6	480	7.5:1	3600
425.9	419.3	403.6	388.7	720	5:1	

Required Motor hp

1/4	1/2	3/4	1	1-1/2	2	3	5	7-1/2	10	15	20
-----	-----	-----	---	-------	---	---	---	-------	----	----	----

Pump Data

Diaphragms per Liquid End	5
Flow Control	Electronic variable speed drive
Maximum Discharge Pressure	
Metallic Heads:	2500 psi (172 bar)
Maximum Inlet Pressure	500 psi (34 bar)
Maximum Operating Temperature	
Metallic Heads:	250° F (121° C)*
Inlet Port	1-1/4 inch NPT or BSPT
Discharge Port	3/4 inch NPT or BSPT
Weight (less motor)**	
Metallic Heads:	192.1 lbs (88.5 kg)
Dimensions (less motor)**	
Metallic Heads:	14.5" W x 24.0" D x 13.9" H (368.3 mm W x 609.6 mm D x 353.1 mm H)

* Consult factory for correct component selection for temperatures from 160° F (71° C) to 250° F (121° C).

** For (NEMA) 56C motor frame only. Consult factory for other motor frame sizes.

Representative Drawings Inches (mm)

Note: Dimensions are for reference only. Contact factory for certified drawings.

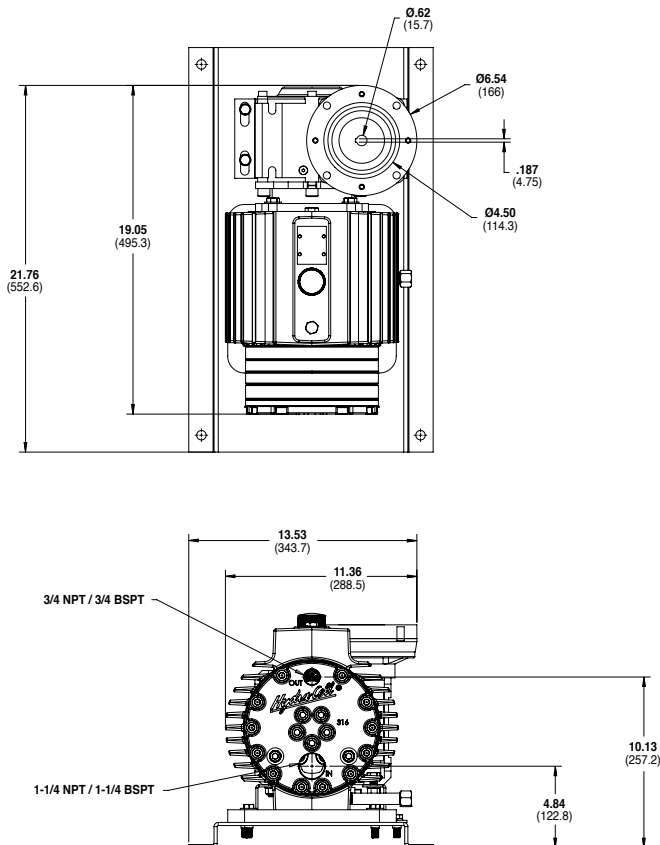

Metallic Pump Heads (NEMA 56C)

For accessories, options, and a system installation example, see page 185.

How to Order

A complete pump order number contains 13 digits based on the specified pump materials listed below.

1	2	3	4	5	6	7	8	9	10	11	12	13
P	5	0	0									

Pump Model Size (Digits 1-4)

P500 For all P500 Pumps (Non Kel-Cell)

Pump Version (Digit 5)

N NPT Ports (NEMA motors only)
M BSPT Ports (IEC motors only)

Pump Head / Retainer Material (Digit 6)

B Brass / Hastelloy C
S 316L Stainless Steel / Hastelloy C
T Hastelloy C / Hastelloy C

Diaphragm & O-ring Material / Oil (Digit 7)▲

A Atlas / PTFE O-rings (Synthetic oil)
X FKM (Synthetic oil)
T Buna-N (Standard oil)

▲ See price list for different actuating oils available with these materials.

Check Valve Material (Digits 8-9)

(Valve Spring / Valve Seat / Valve)

SS Elgiloy / Nitronic 50 / Nitronic 50
TT Hastelloy C / Hastelloy C / Hastelloy C
SD Elgiloy / Tungsten Carbide / Tungsten Carbide
TD Hastelloy C / Tungsten Carbide / Tungsten Carbide

Gearbox Ratio (Digits 10-12) NEMA Motors

060	60:1	(56C Motor Frame)
050	50:1	(56C Motor Frame)
040	40:1	(56C Motor Frame)
A40	40:1	(143/145TC Motor Frame)
030	30:1	(56C Motor Frame)
A30	30:1	(143/145TC Motor Frame)
025	25:1	(56C Motor Frame)
A25	25:1	(143/145TC Motor Frame)
020	20:1	(56C Motor Frame)
A20	20:1	(143/145TC Motor Frame)
015	15:1	(56C Motor Frame)
A15	15:1	(143/145TC Motor Frame)
B15	15:1	(182/184TC Motor Frame)
010	10:1	(56C Motor Frame)
A10	10:1	(143/145TC Motor Frame)
B10	10:1	(182/184TC Motor Frame)
007	7.5:1	(56C Motor Frame)
A07	7.5:1	(143/145TC Motor Frame)
B07	7.5:1	(182/184TC Motor Frame)
C07	7.5:1	(213/215TC Motor Frame)
D07	7.5:1	(254/256TC Motor Frame)
005	5:1	(56C Motor Frame)
A05	5:1	(143/145TC Motor Frame)
B05	5:1	(182/184TC Motor Frame)
C05	5:1	(213/215TC Motor Frame)
D05	5:1	(254/256TC Motor Frame)

Base Plate (Digit 13)

H Carbon Steel (Epoxy painted) for O, A & B reducers, size 75
G Carbon Steel (Epoxy painted) for C & D reducers

P600 Series

Maximum Flow Rate: 890.3 gph

Maximum Pressure: 1000 psi (69 bar) for Metallic Pump Heads
350 psi (24 bar) for Non-metallic Pump Heads

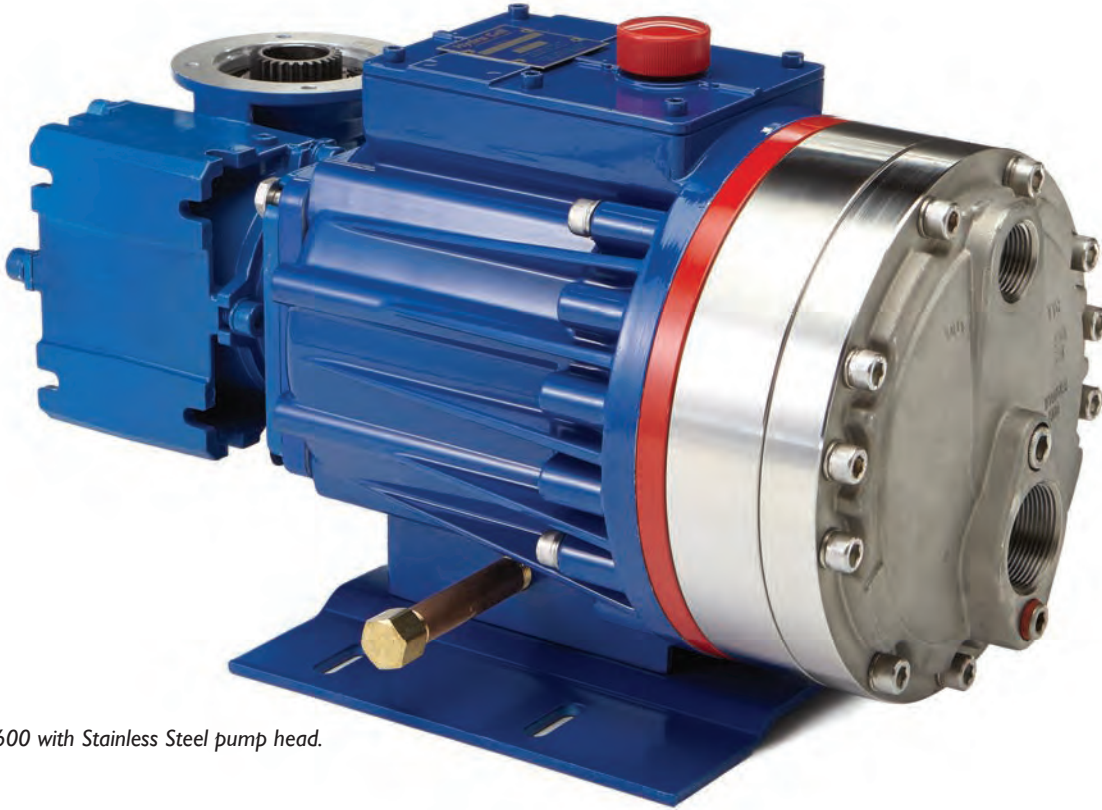

P600 with Stainless Steel pump head.

Performance* Maximum Flow at Designated Pressure

All Pumps (gph)		Metallic Pump Heads Only (gph)		Pump rpm	Gear Ratio	Motor rpm
100 psi	250 psi	500 psi	1000 psi			
36.49	36.12	35.21	33.25	30	60:1	1800
43.90	43.48	42.49	40.35	36	50:1	
55.00	54.53	53.39	51.17	45	40:1	
73.56	72.97	71.58	68.75	60	30:1	
88.41	87.71	86.12	82.81	72	25:1	
110.7	109.8	107.9	103.9	90	20:1	
147.8	146.7	144.3	139.1	120	15:1	
222.1	220.4	217.0	209.4	180	10:1	
296.3	294.1	289.8	279.7	240	7.5:1	
444.8	441.6	435.2	420.3	360	5:1	
593.3	589.0	580.7	560.9	480	7.5:1	3600
890.3	883.9	871.6	842.1	720	5:1	

* Capacity data is shown for pumps with elastomeric diaphragms. Consult factory for performance characteristics of pumps with PTFE diaphragms.

Required Motor hp

1/2	3/4	1	1-1/2	2	3	5	7-1/2	10	15
-----	-----	---	-------	---	---	---	-------	----	----

Pump Data

Diaphragms per Liquid End	3
Flow Control	Electronic variable speed drive
Maximum Discharge Pressure	
Metallic Heads:	1000 psi (69 bar)
Non-metallic Heads:	PVDF- 350 psi (24 bar) Polypropylene- 250 psi (17 bar)
Maximum Inlet Pressure	250 psi (17 bar)
Maximum Operating Temperature	
Metallic Heads:	250 °F (121 °C)*
Non-metallic Heads:	140 °F (60 °C)
Inlet Port	1-1/2 inch NPT or BSPT
Discharge Port	1 inch NPT or BSPT
Weight (less motor)**	
Metallic Heads:	146.0 lbs (66.2 kg)
Non-metallic Heads:	111.0 lbs (50.3 kg)
Dimensions (less motor)**	
Metallic Heads:	10.74" W x 20.64" D x 11.57" H (272.7 mm W x 524.3 mm D x 293.9 mm H)
Non-metallic Heads:	10.74" W x 21.56" D x 11.57" H (272.7 mm W x 547.6 mm D x 293.9 mm H)

* Consult factory for correct component selection for temperatures from 160° F (71° C) to 250° F (121° C).

** For (NEMA) 56C motor frame only. Consult factory for other motor frame sizes.

Representative Drawings Inches (mm)

Note: Dimensions are for reference only. Contact factory for certified drawings.

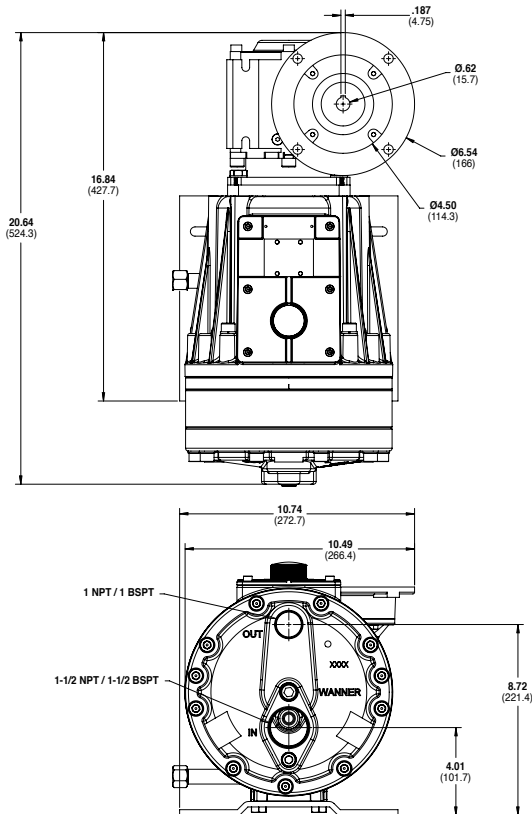

Metallic Pump Heads (NEMA 56C)

For accessories, options, and a system installation example, see page 185.

How to Order

A complete pump order number contains 13 digits based on the specified pump materials listed below.

1	2	3	4	5	6	7	8	9	10	11	12	13
P	6	0	0									

Pump Model Size (Digits 1-4)

P600 For all P600 Pumps (Kel-Cell)

Pump Version (Digit 5)

N NPT Ports or ANSI Flanges (NEMA motors only)

M BSPT Ports or ANSI Flanges (IEC motors only)

Pump Head / Retainer Material (Digit 6)

B Brass / Hastelloy C

C Cast Iron / Hastelloy C

M PVDF / PVDF

P Polypropylene / Polypropylene

R 316L SST (ANSI flange class 150 x 600) / Hastelloy C

S 316L SST (NPT or BSPT) / Hastelloy C

T Hastelloy CW12MW / Hastelloy C

Diaphragm & O-ring Material / Oil (Digit 7)▲

A Atlas / PTFE O-rings (Synthetic oil)

E EPDM (EPDM-compatible oil)

X FKM (Synthetic oil)

J PTFE (Food-contact oil)

P Neoprene (Standard oil)

T Buna-N (Standard oil)

▲ See price list for different actuating oils available with these materials.

Check Valve Material (Digits 8-9)

(Valve Spring / Valve Seat / Valve)

SS Elgiloy / Nitronic 50 / Nitronic 50

TT Hastelloy C / Hastelloy C / Hastelloy C

SC Elgiloy / Ceramic / Ceramic

TC Hastelloy C / Ceramic / Ceramic

SD Elgiloy / Tungsten Carbide / Tungsten Carbide

TD Hastelloy C / Tungsten Carbide / Tungsten Carbide

Gearbox Ratio (Digits 10-12) NEMA Motors

060	60:1	(56C Motor Frame)
050	50:1	(56C Motor Frame)
040	40:1	(56C Motor Frame)
A40	40:1	(143/145TC Motor Frame)
030	30:1	(56C Motor Frame)
A30	30:1	(143/145TC Motor Frame)
025	25:1	(56C Motor Frame)
A25	25:1	(143/145TC Motor Frame)
020	20:1	(56C Motor Frame)
A20	20:1	(143/145TC Motor Frame)
015	15:1	(56C Motor Frame)
A15	15:1	(143/145TC Motor Frame)
B15	15:1	(182/184TC Motor Frame)
010	10:1	(56C Motor Frame)
A10	10:1	(143/145TC Motor Frame)
B10	10:1	(182/184TC Motor Frame)
007	7.5:1	(56C Motor Frame)
A07	7.5:1	(143/145TC Motor Frame)
B07	7.5:1	(182/184TC Motor Frame)
C07	7.5:1	(213/215TC Motor Frame)
D07	7.5:1	(254/256TC Motor Frame)
005	5:1	(56C Motor Frame)
A05	5:1	(143/145TC Motor Frame)
B05	5:1	(182/184TC Motor Frame)
C05	5:1	(213/215TC Motor Frame)
D05	5:1	(254/256TC Motor Frame)

Base Plate (Digit 13)

C Carbon Steel (Epoxy painted) for 0 reducers, size 63

H Carbon Steel (Epoxy painted) for A & B reducers size 75

G Carbon Steel (Epoxy painted) for C & D reducers

P700 Series

Maximum Flow Rate: 1394 gph (4396 lph)

Maximum Pressure: 1200 psi (83 bar) for Metallic Pump Heads

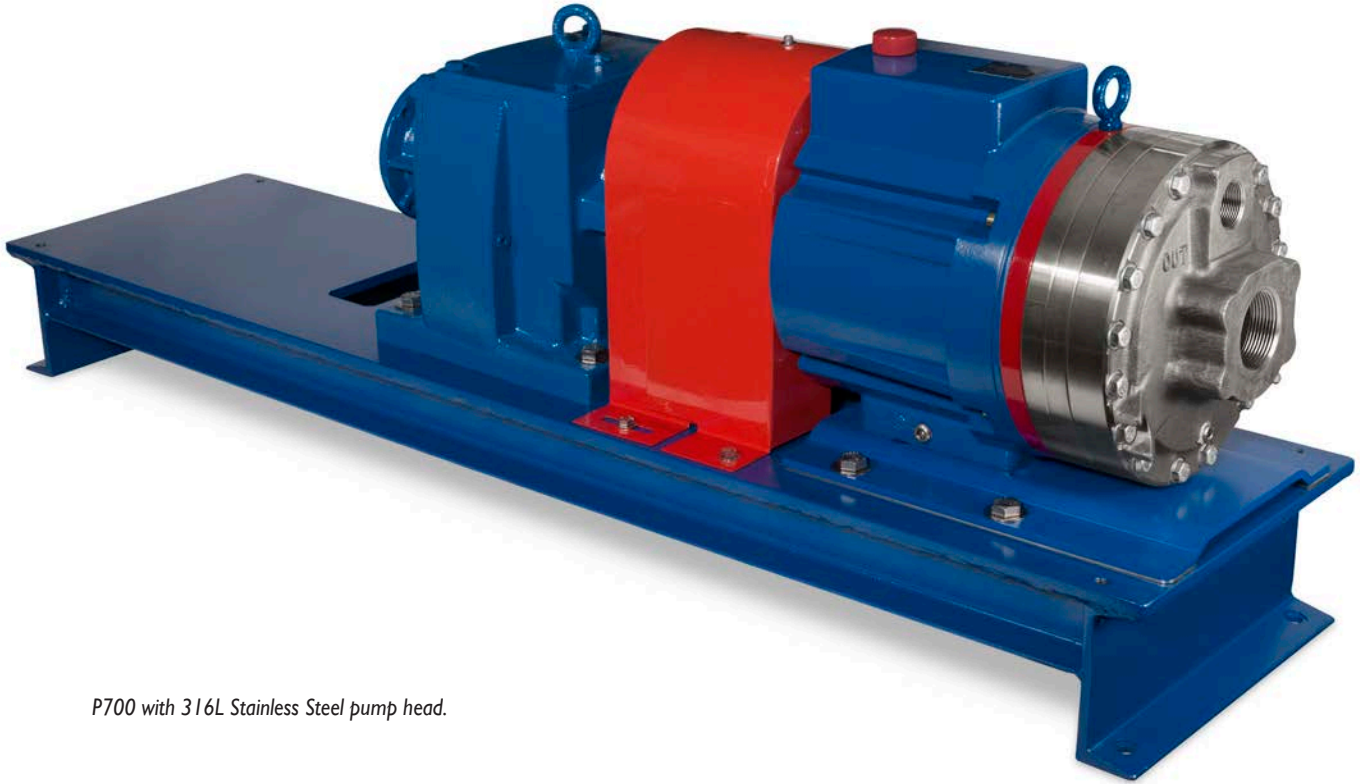

P700 with 316L Stainless Steel pump head.

Performance* Maximum Flow at Designated Pressure

100 psi	Metallic Pump Heads Only (gph)			Pump rpm	Gear Ratio	Motor rpm
	500 psi	1000 psi	1200 psi			
208	195	183	173	96	18.67:1	1800
254	242	222	214	119	15.18:1	
370	356	336	324	172	10.44:1	
706	676	648	636	318	5.66:1	
416	402	386	378	193	18.67:1	3600
514	500	478	472	237	15.18:1	
754	732	708	700	345	10.44:1	
1394	1366	1332	1314	636	5.66:1	

* Capacity data is shown for pumps with elastomeric diaphragms. Consult factory for performance characteristics of pumps with PTFE diaphragms.

Required Motor hp

2	3	5	7-1/2	10	15	20
---	---	---	-------	----	----	----

Pump Data

Diaphragms per Liquid End	5 with Advanced Diaphragm Position Control (ADPC)
Flow Control	Electronic variable speed drive
Maximum Discharge Pressure	
Metallic Heads:	1200 psi (83 bar)
Maximum Inlet Pressure	250 psi (17 bar)
Maximum Operating Temperature	
Metallic Heads:	250° F (121° C)*
Maximum Solids Size	800 microns
Inlet Port	2-1/2 inch NPT/BSPT or 3 inch SAE J518 flange
Discharge Port	1-1/4 inch NPT/BSPT or 1-1/4 inch SAE J518 flange
Shaft Rotation	Bi-directional
Oil Capacity	7.75 US quarts (7.4 liters)
Weight (less motor)	
Metallic Heads:	638 to 685 lbs (289 to 311 kg)
Dimensions (less motor)**	
Metallic Heads:	11.53" W x 39.51" D x 15.11" H (292.9 mm W x 1003 mm D x 383.8 mm H)

* Consult factory for correct component selection for temperatures from 160° F (71° C) to 250° F (121° C).

** For (NEMA) 143/45TC motor frames only. Consult factory for other motor frame sizes.

Representative Drawings Inches (mm)

Note: Dimensions are for reference only. Contact factory for certified drawings.

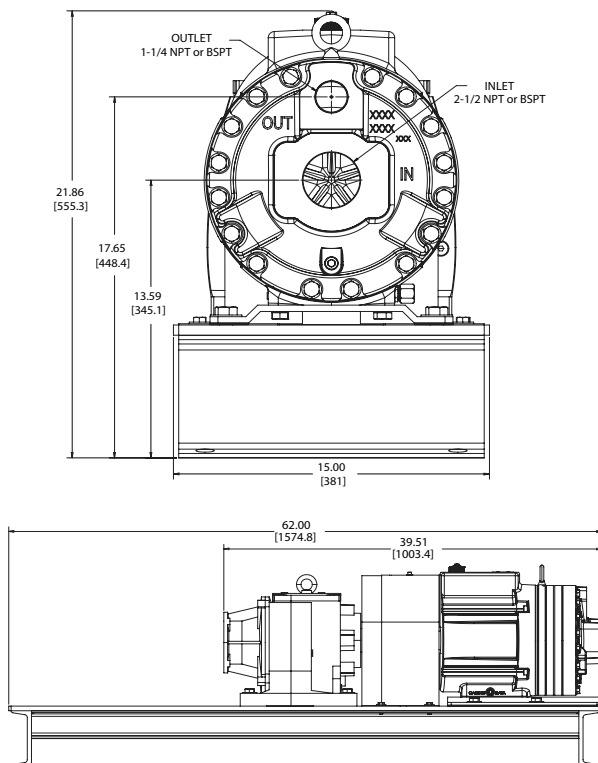

Metallic Pump Heads (NEMA 143/145TC)

For accessories, options, and a system installation example, see page 185.

How to Order

A complete pump order number contains 13 digits based on the specified pump materials listed below.

1	2	3	4	5	6	7	8	9	10	11	12	13
P	7	0	0									

Pump Model Size (Digits 1-4)

P700	For all P700 Pumps (Advanced Diaphragm Position Control)
-------------	--

Pump Version (Digit 5)

N	NPT Ports or SAE Flanges (NEMA motors only)
M	BSPT Ports or SAE Flanges (IEC motors only)

Pump Head / Retainer Material (Digit 6)

B	Brass / PVDF
C	Ductile Iron (Nickel-plated) / PVDF
G	Duplex Alloy 2205 Stainless Steel (with Hastelloy C followers & follower screws) / Hastelloy C
A	316 Stainless Steel ANSI flange class 600 x 1500 / Hastelloy C
D	316 Stainless Steel ANSI flange class 150 x 600 / Hastelloy C
S	316L Stainless Steel Threaded or SAE Ports / Hastelloy C
T	Hastelloy C / Hastelloy C

Diaphragm & O-ring Material / Oil (Digit 7)

A	Aflas / PTFE O-rings (Synthetic oil)
E	EPDM (EPDM-compatible oil)
X	FKM (Synthetic oil)
J	PTFE (Food-contact oil)
W	PTFE (Synthetic oil)
Z	Neoprene (Synthetic oil)
Y	Buna-N (Synthetic oil)

Check Valve Material (Digits 8-9)

(Valve Spring / Valve Seat / Valve)

SS	Elgiloy / Nitronic 50 / Nitronic 50
TT	Hastelloy C / Hastelloy C / Hastelloy C
SC	Elgiloy / Ceramic / Ceramic
TC	Hastelloy C / Ceramic / Ceramic
TD	Hastelloy C / Tungsten Carbide / Tungsten Carbide

Gearbox Ratio (Digits 10-12) NEMA Motors

A18	18.67:1	(143/145TC Motor Frame)
B18	18.67:1	(182/184TC Motor Frame)
C18	18.67:1	(213/215TC Motor Frame)
A15	15.18:1	(143/145TC Motor Frame)
B15	15.18:1	(182/184TC Motor Frame)
C15	15.18:1	(213/215TC Motor Frame)
D15	15.18:1	(254/256TC Motor Frame)
B10	10.44:1	(182/184TC Motor Frame)
C10	10.44:1	(213/215TC Motor Frame)
D10	10.44:1	(254/256TC Motor Frame)
B05	5.66:1	(182/184TC Motor Frame)
C05	5.66:1	(213/215TC Motor Frame)
D05	5.66:1	(254/256TC Motor Frame)

Base Plate (Digit 13)

C	Carbon Steel (Epoxy painted)
----------	------------------------------

Hydra-Cell® Metering Accessories and Options

System Illustration

Note: Applicable to all P Series pumps and the MT8 pump.

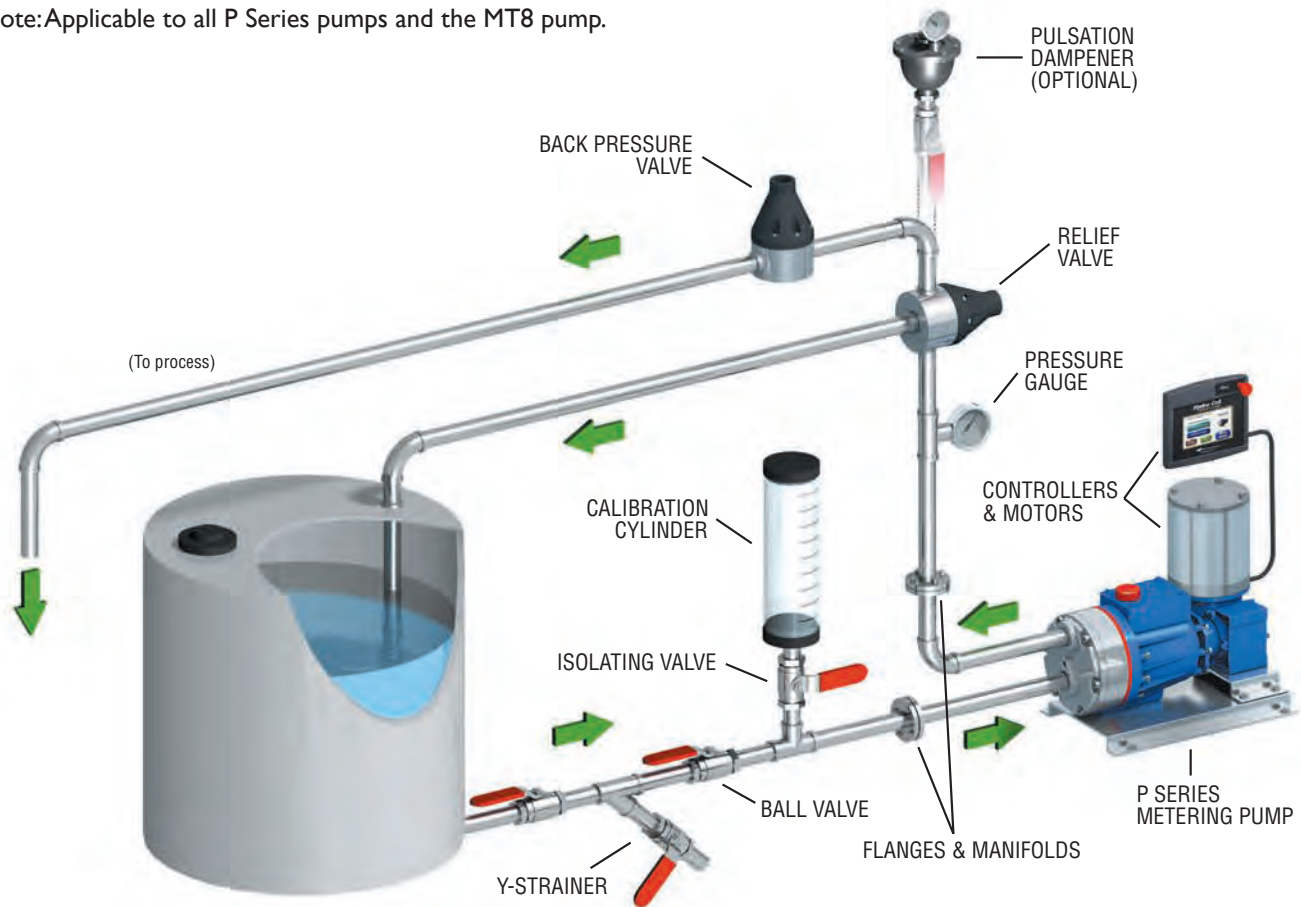

Hydra-Cell metering pumps are just one facet of a complete Hydra-Cell “Metering Solutions” system. We can furnish all components in your pumping system, individually tailored to your specific processing needs.

- Calibration cylinders.
- Back pressure valves.
- Pressure relief valves.
- Pulsation dampeners.
- Motors and motor adapters.
- Motor controllers.
- Variable frequency drives (VFD).
- Diaphragm materials.
- Liquid end and check valve materials.
- Gearbox ratios.
- Manifolds and flanges.
- Strainers.
- Suction accumulators.
- Actuating oils.
- Witnessed and non-witnessed testing.
- Drawing packages.
- OEM paint and nameplate customization.

See the Accessories section of this catalog, beginning on page 92 for more detailed information about the selection process and specific part numbers.

Hydra-Cell® Bare Shaft Pumps for Metering



Note: Bare shaft pumps for metering must use X-cams and operate at speeds not exceeding those shown in the table.

In certain less critical metering and injecting applications, Hydra-Cell Seal-less Pumps (without gearbox reducers) provide an alternative to Hydra-Cell Metering Solutions

Pumps. They can meet API 675 performance standards for accuracy, linearity, and repeatability - a must for metering pumps. Bare shaft pumps can be used when:

- Flow capacities required exceed those of Hydra-Cell Metering Solutions pumps (see page 163).
- Flow rates for the application do not need to be as precise as what Hydra-Cell Metering Solutions pumps deliver.
- Space limitations or application parameters dictate the use of a direct drive or belt drive.
- Special components designed to resist chemical attack, such as epoxy-coated manifold plates and bases are not needed.
- Metering requirements can be met (including API 675) without using a gearbox reducer (or other components) thus lowering acquisition cost.

Capacities and Ratings

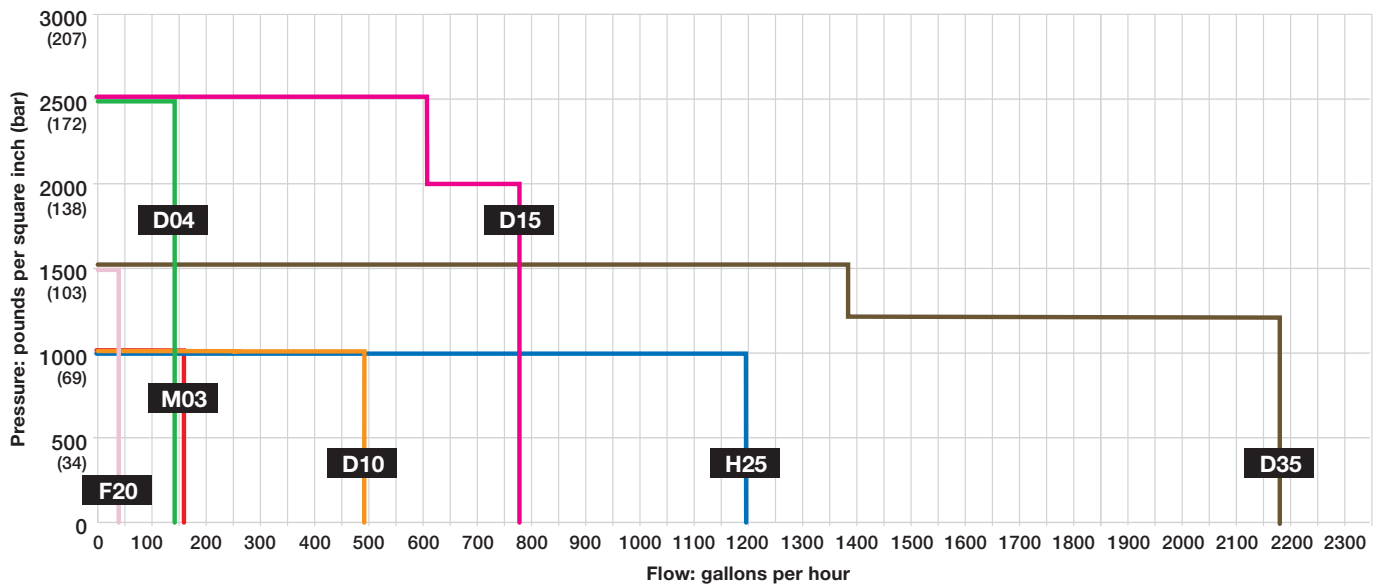

Model ¹	Maximum Capacity gph	Maximum Discharge Pressure psi (bar)		Maximum Operating Temperature F (C) ³		Maximum Inlet Pressure psi (bar)	Rated rpm for Metering ⁴
		Non-metallic ²	Metallic	Non-metallic	Metallic		
F20	36.6	350 (24)	1500 (103)	140° (60°)	250° (121°)	250 (17)	1050
M03	155.5	350 (24)	1000 (69)	140° (60°)	250° (121°)	250 (17)	1440
D04	146.9	N/A	2500 (172)	N/A	250° (121°)	500 (34)	1440
D10	256.0	N/A	1500 (103)	N/A	250° (121°)	250 (17)	790
D10	483.8	350 (24)	1000 (69)	140° (60°)	250° (121°)	250 (17)	1440
D15	607.2	N/A	2500 (172)	N/A	250° (121°)	500 (34)	1150
D15	777.6	N/A	2000 (138)	N/A	250° (121°)	500 (34)	1440
H25	1197.0	350 (24)	1000 (69)	140° (60°)	250° (121°)	250 (17)	1050
D35	1386.0	N/A	1500 (103)	N/A	250° (121°)	250 (17)	700
D35	2186.1	N/A	1200 (83)	N/A	250° (121°)	500 (34)	1050

¹ Ratings are for X-cam design, which must be used for metering.

² 350 psi (24 bar) maximum with PVDF liquid end; 250 psi (17 bar) maximum with Polypropylene liquid end.

³ Consult factory for correct component selection for temperatures from 160°F (71°C) to 250°F (121°C).

⁴ Do not exceed speeds (rpm) shown.

Hydra-Cell® S Series Solenoid Metering Pumps

The S Series pumps provide an economical choice for chemical injection in metering applications.

Solenoid driven, the S pumps feature a wide discharge-volume range, extensive choice of liquid end materials, various control functions, and a wide voltage range.

Materials of construction choices and versatile design options result in pumps perfected for specific applications including general chemicals, high-pressure boiler, high-viscosity fluids, outgassing and more.

Flow Rate	SM Series Models	SP/ST/SA Series Models
30 ml/min*	SM030	SP/ST/SA-030
60 ml/min	SM060	SP/ST/SA-060
100 ml/min	SM100	SP/ST/SA-100
220 ml/min	N/A	SP/ST/SA-200
With Relief Valve		
30 ml/min*	SM03R	SP/ST/SA-03R
60 ml/min	SM06R	SP/ST/SA-06R
100 ml/min	SM10R	SP/ST/SA-10R

* High-pressure models have maximum flow rates of either 25 or 28 ml/min. Consult S Series catalog for more information.



SM030CAS manual control with stroke speed dial.

SP060HVS with pulse-input control and digital readout.

ST03RPES with pulse-input control and digital readout.

SA03RPES with pulse-input/analog-input and digital readout.



Spare parts kits to help extend service life.

S Series solution tanks are available in three sizes to provide compact systems for chemical injection.



30L (7.9 gal)

50L (13.2 gal)

120L (31.7 gal)

Hydra-Cell® Frequently Asked Questions

What type of oil should be used with Hydra-Cell pumps?

The pump lubricant in Hydra-Cell pumps performs two functions: (1) it provides flooded oil lubrication to the bearings; (2) it provides hydraulically-balanced displacement to the diaphragms.

Critical to the hydraulic system within each piston, the oil must flow smoothly under high pressures.

Hydra-Oil is available in a variety of standard-duty motor oils, synthetic, EPDM-compatible, and food-grade lubricants to meet these requirements.

Which way do I rotate the shaft when setting up the drive for my Hydra-Cell pump?

Either way.

The smooth, positive displacement delivery of a Hydra-Cell pump can be achieved when rotating the shaft in either direction.

What happens if a Hydra-Cell pump runs dry?

“Nothing.”

The unique, seal-less design of Hydra-Cell means that the pump does not require lubrication from the process fluid. In the event of your tank or product source running dry, and air being pulled through the pump, no damage will occur. As fluid again is available, the Hydra-Cell pump will resume pumping.

What is the maximum particle size that can pass through a Hydra-Cell pump?

Up to 800 microns depending on pump model.

Round particles up to 200 microns can pass through Hydra-Cell models F20, M03, D03, and D04. 500-micron particles can pass through models D10, D12, and D15/D17. 800-micron particles can pass through the H25, D35, and D66 model pumps. Critical to the successful pumping of particulates is ensuring that all particles are fully suspended in the fluid to avoid any settling of the solids. Key factors include fluid velocity (pump speed) and particle mass. With intermittent duty, care must be taken to avoid excessive settling in the inlet and discharge plumbing.

What is the maximum hardness number on the Mohs Mineral Hardness Scale that Hydra-Cell pumps can handle?

9 Mohs on a scale of 1 to 10.

Is a pressure relief valve necessary when using the Hydra-Cell pump?

Yes.

The positive displacement performance of the Hydra-Cell pump requires that each application has a pressure regulating valve in the discharge line to allow fluid to divert in the event that excessive pressure builds in the system. Hydra-Cell C Series valves provide this protection for your high-pressure system.

How long can I expect the diaphragms to last?

Indefinitely.

When installed properly and no adverse stresses are applied to our elastomeric diaphragms (e.g. excessive vacuum, foreign matter, etc.) the hydraulically-balanced diaphragm will not be a wear component.

Due to their poor elastomeric memory, PTFE diaphragms will eventually wear. Maximum life can be achieved with reduced stroke cams and/or by limiting pump speed.

Are Hydra-Cell pumps easy to service?

Yes.

Hydra-Cell pumps are engineered to be easy and inexpensive to service. With regular oil changes, most wear is restricted to the check valve components in the fluid end pump head. All wear items are available in repair kits that include service and parts manuals to allow for fast and easy repairs in the field.

All repair manuals are available on our website (www.Hydra-Cell.com). Online videos are also available – contact us for details.

What determines an application duty cycle?

A continuous-duty cycle is typically defined as a pump running more than 8 hours per day, 5-to-7 days a week. Continuous applications running at or near maximum pressure may benefit and achieve a longer pump life by sizing the application with the next larger pump model.

Running a pump for shorter periods (intermittent-duty cycle) than a continuous-duty cycle under high temperatures or heavy loads may also affect pump duty selection. In addition, for excessive heat applications (greater than 180°F/82°C) using an oil cooler is recommended.

How can the right flow be produced for a pump application?

Hydra-Cell pumps use positive displacement performance to produce a steady, dependable flow at pressures from 50 to 2500 psi (3.4 to 172 bar). The output of the pump is entirely dependent on the shaft rpm. Once the required flow rate is known, there are many ways to drive the pump. Shaft coupling directly to a motor with a motor adapter is the most popular drive arrangement.

All our pump models utilize different output crankshafts or cams to produce different flow rates at common electric motor speeds (e.g., 1150, 1450, 1750 rpm with 60 Hz power, etc.). In addition, pumps and motors can be mounted side-by-side and pulley driven with V-belts or cog style belts (see calculating pulley size formula on page 180). Other drive configurations include hydraulic motors, air motors, gas engines, PTO or any other means to drive the shaft.

Hydra-Cell® Design Considerations

Technical Pump Selection

To properly specify a pump to meet a specific application requirement, use a copy of the application worksheet found on page 199. Please feel free to contact us or your local Hydra-Cell distributor for assistance in calculating the appropriate pump for your application.

Chemical Compatibility

Chemical compatibility of the pump materials of construction with the pumped fluid is a critical design consideration. Factors that must be reviewed as part of chemical compatibility include:

- Temperature
- Concentration
- Presence of other chemicals

Temperature

Temperature factors that must be reviewed as part of this evaluation include:

- Stability of fluid
- Fluid end components
- Hydraulic end lubricity
- Vapor pressure

Inlet Pressure

Inlet pressure to the pump is determined by the design of the pump system: flooded (gravity fed); suction lift; or pressure fed. Do not exceed vacuum and pressure limits as designated in the pump IOM Manual.

NPSH (Net Positive Suction Head)

Two NPSH values are involved in pump selection: NPSHr (required head) and NPSHa (available head). NPSHa must be greater than NPSHr. If not, the pressure in the pump inlet will be lower than the vapor pressure of the fluid, and cavitation will occur. Use the following calculations as a guideline only.

Calculating NPSHa

Use the following formula to calculate NPSHa:

$$\text{NPSHa} = \text{Pt} + \text{Hz} - \text{Hf} - \text{Ha} - \text{Pvp}$$

where:

- Pt = Atmospheric pressure in feet or meters of water. (Use Atmospheric Pressure chart in next column.)
- Hz = Vertical distance from the liquid surface to the pump centerline in feet or meters. (If liquid is below the pump centerline, Hz is a negative value.)
- Hf = Friction losses in suction piping. (Consult a reference for this calculation such as Cameron Hydraulic Data or similar.)
- Ha = Acceleration head at pump suction. (See Calculating Acceleration Head formula in next column.)
- Pvp = Absolute vapor pressure of liquid at pumping temperature.

Note: Be sure to use consistent units, either all feet or all meters.

Atmospheric Pressure at Various Altitudes

Altitude		Pressure	
Feet	Meters	Ft. of H ₂ O	M of H ₂ O
0	0	33.9	10.3
500	152.4	33.3	10.1
1000	304.8	32.8	10.0
1500	457.2	32.1	9.8
2000	609.6	31.5	9.6
5000	1524.0	28.2	8.6

Calculating Acceleration Head (Ha)

Use the following formula to calculate Ha losses. Subtract this figure from the NPSHa and compare the result to the NPSHr of the appropriate Hydra-Cell pump (NPSHr curves in pump specification section).

$$\text{Ha} = \frac{\text{L} \times \text{V} \times \text{N} \times \text{C}}{\text{K} \times \text{G}}$$

where:

- Ha = Acceleration head (in feet or meters of liquid).
- L = Actual length of suction line (feet or meters) - not equivalent length.
- V = Velocity of liquid in suction line (ft./sec or m/sec)
For imperial units: I.D. in inches
[V = gpm × (0.408 ÷ pipe I.D.²)]
For metric units: I.D. in mm
[V = lpm × (21.221 ÷ pipe I.D.²)]
- N = rpm of crank shaft.
- C = Constant determined by type of pump/Hydra-Cell: (consult your Hydra-Cell Installation & Service Manual).
- K = Constant of compensate for compressibility of the fluid – use:
 - 1.4 for de-aerated or hot fluids
 - 1.5 for most liquids
 - 2.5 for hydrocarbons with high compressibility
- G = Gravitational constant:
 - Imperial: 32.2 ft./sec²
 - Metric: 9.81 m/sec²

Minimizing Acceleration Head

- Keep inlet lines less than 6 ft. (1.8 m) long
- Use appropriate size I.D. inlet hose
- Use flexible hose (low-pressure hose, non-collapsing) for inlet lines
- Minimize fittings (elbows, valves, tees, etc.)
- Use suction stabilizer on the inlet

Hydra-Cell® Installation Guidelines

General Installation

1. Read and follow all instructions and safety warnings in the Hydra-Cell IOM Manual.
2. Do not exceed the manufacturer's recommended maximum rpm or pressure.
3. Follow all codes and regulations regarding installation and operation of the pumping system.
4. For safety and easier servicing, provide adequate work space around the pump. Allow room for checking the oil level, changing the oil, and removing the valve plate and manifold.
5. To prevent vibration, mount the pump and motor securely to a rigid, level base.
6. Be sure the inlet system provides NPSHa that exceeds the sum of NPSHr of the pump, all friction losses and acceleration head.
7. Do not exceed the manufacturer's recommended maximum inlet pressure. Install an inlet pressure regulator if necessary.
8. On a belt-drive system, align the belts and pulleys accurately, and follow the manufacturer's specifications for belt tension.
9. On a direct-drive system, align shafts properly.
10. Install adequate safety guards on all belts and couplings.
11. Install drains in all low points of the system to allow draining in freezing conditions.

Supply Tank Guidelines

1. Use a supply tank that is large enough to provide time for any entrapped air in the fluid to escape.
2. Isolate the pump and motor stand from the supply tank and support them separately.
3. Where possible, install a separate inlet line from the supply tank to each pump. Alternatively, target 1 ft/sec manifold velocity.
4. Install the inlet and bypass lines so that they empty into the supply tank below the lowest water level, on the opposite side of the baffle from the pump inlet line.
5. If a line strainer is used in the system, install it in the inlet line to the supply tank.
6. Install a completely-submerged baffle plate in the supply tank to separate the incoming and outgoing liquid so as to reduce aeration and turbulence.
7. Install a vortex breaker in the supply tank over the outlet port to the pump.
8. Place a cover on the supply tank to prevent foreign objects from falling into it.

Calculating Pulley Size

$$\frac{\text{motor pulley OD}}{\text{pump rpm}} = \frac{\text{pump pulley OD}}{\text{motor rpm}}$$

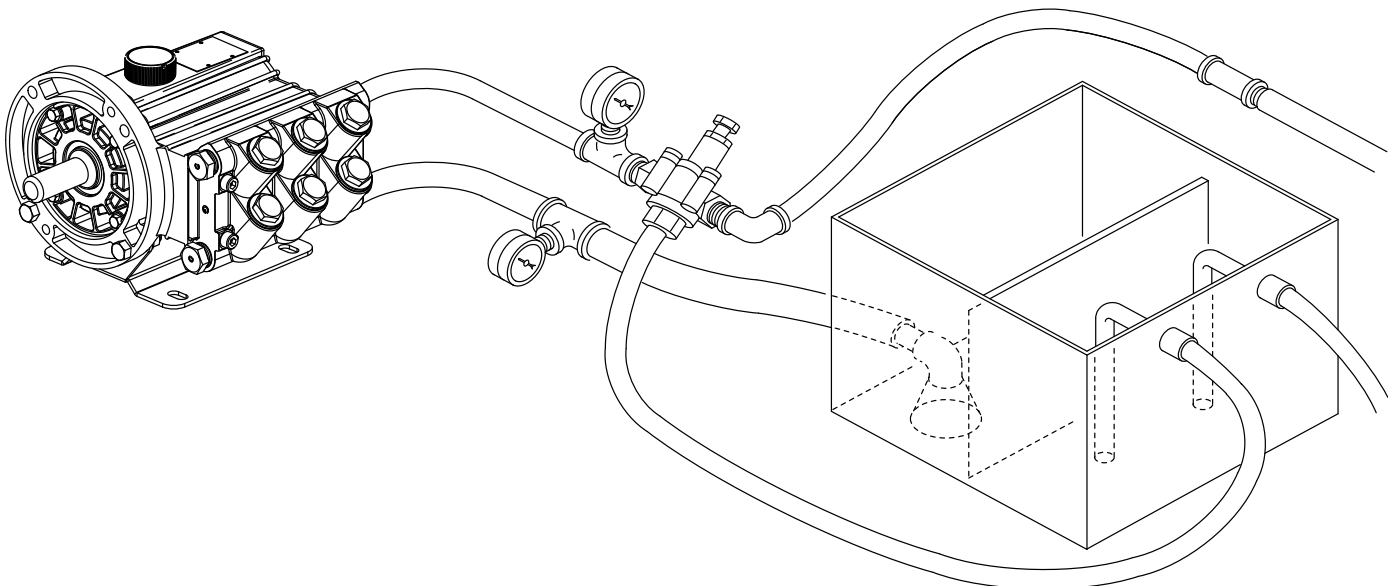

Hydra-Cell® Installation Guidelines

Inlet Piping Guidelines

1. Size the suction line so that the velocity will not exceed 1 to 3 ft/sec. $Velocity = 0.408 \times \text{gpm}/\text{Pipe I.D.}^2$. Multiple-pump installations require 1 ft/sec.
2. Keep the suction line as short and straight as possible, without any obstructions (e.g., valves, elbows, tees) within 10 pipe diameters of the pump inlet.
3. Use flexible, non-collapsible suction hose and/or expansion joints to absorb vibrations, expansions and contractions.
4. If possible, keep suction line level. Have no high points to collect vapor unless these high points are vented. Install drain cocks at any low points of the suction line to permit draining in freezing conditions.
5. Provide for permanent or temporary installation of a vacuum gauge to monitor the inlet suction.
6. It is recommended not to supply more than one pump from the same inlet line.
7. To reduce turbulence and resistance, do not use 90° elbows. If turns are necessary in the suction line, use 45° elbows (within 10 pipe diameters of the pump inlet) or arrange sweeping curves in the inlet hose.
8. If a block valve is used, be sure it is full-opening so that the flow to the pump is not restricted. The opening should be at least the same diameter as the inlet plumbing I.D.
9. It is recommended that a line strainer or filter not be used in the suction line unless regular maintenance is assured. If used, it should have a free-flow area at least three times the free-flow area of the inlet.
10. Install piping supports where necessary to relieve strain on the inlet line and to minimize vibration.

Discharge Line Guidelines

1. Size the discharge line so that the velocity will not exceed 8 to 10 ft/sec.
2. Use flexible hose between the pump and hard piping to absorb vibrations, expansions or contractions.
3. Install a pressure gauge between the pump and the pressure regulator, and as close as possible to the pump outlet.
4. Install a pressure regulator, unloader valve, or another safety relief valve in the discharge line.
5. Never install a shut-off valve in the discharge line between the pump and the regulator, or in the bypass line.

Pressure Regulator (Relief Valve) Guidelines

1. Size the pressure regulator valve so that when fully open, it will be large enough to relieve the full capacity of the pump without excessive over-pressurizing of the system.
2. Locate the valve as close to the pump as possible and ahead of any other valves.
3. Adjust the pressure regulating valve to no more than 10% over the maximum working pressure of the system. Do not exceed the manufacturer's pressure rating for the pump and/or regulator.

Hydra-Cell® Materials of Construction Reference

Identifying Metallic Components

Since it is often difficult to distinguish between metallic materials used, identification marks have been added to several machined metallic components of Hydra-Cell pumps and valves.

Valve (Pumps)

Identified by 0.003-inch (0.08mm) ledges (or no ledges) on one face.

Nitronic 50	3 ledges
17-4 SST	2 ledges
316L SST	1 ledge
Hastelloy C	No ledges

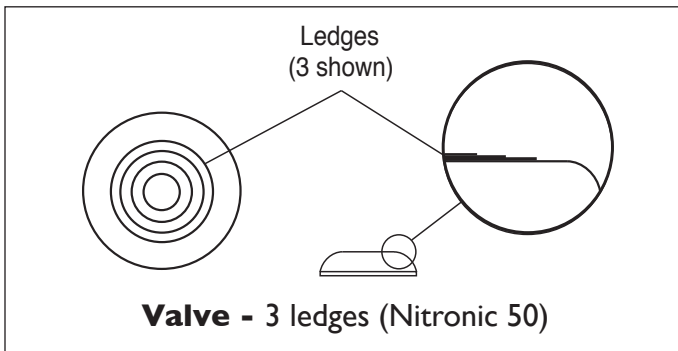

Valve Seat (Pumps)

Identified by circular V-shaped grooves (or no grooves) on one face.

Nitronic 50	3 grooves
17-4 SST	2 grooves
316L SST	1 groove
Hastelloy C	No groove

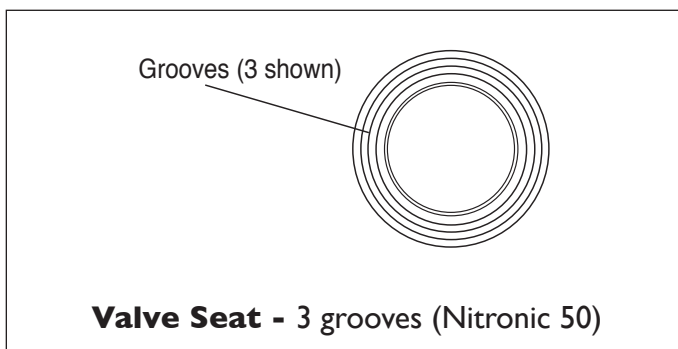

Plunger (C22/C23/C24 Valves)

Identified by ridges (or no ridges) around the tapered end.

17-4 SST	2 ridges
316L SST	1 ridge
Hastelloy C	No ridges

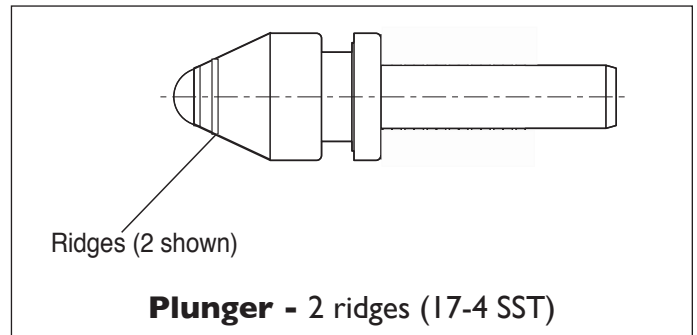

Plunger Seat (C22/C23/C24 Valves)

Identified by circular V-shaped grooves (or no grooves) on one face.

17-4 SST	2 grooves
316L SST	1 groove
Hastelloy C	No groove

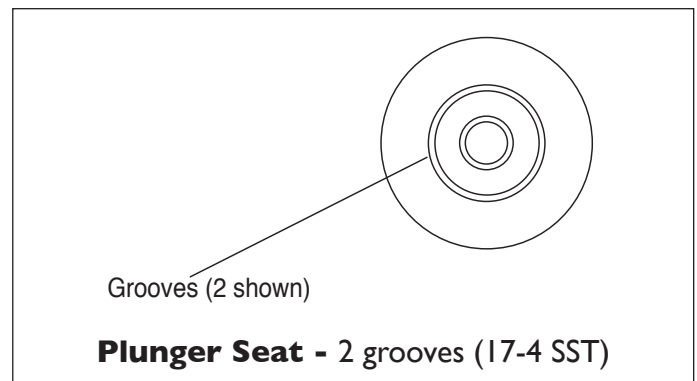

Hydra-Cell® Materials of Construction Reference

Celcon Valve Spring Retainers

Also known as Polyoxymethylene, Celcon is a thermoplastic characterized by high strength, hardness, and rigidity. It is a highly abrasion-resistant and heat-resistant material with a low coefficient of friction.

Elgiloy Valve Springs

A Cobalt-Nickel spring alloy, Elgiloy is highly recommended to reduce valve spring problems as it tested and proved to exceed Stainless Steel for many applications.

- Corrosion Resistance:** Far superior to Stainless Steel
- Greater Spring Efficiency:** Increased power with decreased size
- Fatigue Resistance:** Operates significantly longer without breaking
- Set Resistance:** Maintains constant reactive force
- Temperature Resistance:** Maintains spring characteristics up to 600°F (316°C)

Nitronic 50 Valve Seats and Valves

Nitronic 50 is an austenitic Stainless Steel that has greater corrosion resistance than 316, 316L, 317, and 317L Stainless Steel. It has very good mechanical properties at both elevated and sub-zero temperatures and a yield strength of three-times to four-times greater than 316 Stainless Steel.

Diaphragm Start-up Temperatures and Material Markings

The back side of diaphragms for Hydra-Cell pumps have a letter marking to identify the material from which the diaphragm is made. (There may be additional markings, such as those to indicate mold numbers.)

Diaphragm Material	Pump Start-up Temperature Range	Minimum Fluid Temperature ¹	Marking
Aflas	77 to 250 °F (25 to 121.1 °C)	77 °F (25 °C)	A
Buna-N	30 to 230 °F (-1.1 to 110 °C)	15 °F (-9.4 °C)	NP ²
Neoprene	50 to 120 °F (10 to 48.9 °C)	15 °F (-9.4 °C)	NE
EPDM	50 to 212 °F (10 to 100 °C)	15 °F (-9.4 °C)	EP
FKM	40 to 250 °F (4.4 to 121.1 °C)	15 °F (-9.4 °C)	V
PTFE	60 to 200 °F (15.6 to 93.3 °C)	40 °F (4.4 °C)	³

¹ Fluid temperature after pump is warmed to minimum start-up temperature.

² Buna-N diaphragms for T100 Medium Pressure pumps use H instead of NP.

³ PTFE diaphragms are constructed with a light-blue PTFE material laminated onto a black rubber backing and do not have identification markings.

⁴ For T & Q Series minimum temperatures, please refer to the Installation and Service Manual.

Valve Retainer Temperatures and Material Markings

Non-metallic valve retainers used in Hydra-Cell pumps are color-coded to identify the material from which the retainer is made.

Valve Retainer Material	Fluid Temperature	Marking
Celcon (Polyacetal)	15 to 160 °F (-9.4 to 71.1 °C)	Black
PVDF	15 to 160 °F (-9.4 to 71.1 °C)	White
Nylon (Zytel)	15 to 160 °F (-9.4 to 71.1 °C)	Blue
Polypropylene	15 to 160 °F (-9.4 to 71.1 °C)	Red
Metal	15 to 250 °F (-9.4 to 121.1 °C)	

For hydraulic oil temperatures above 180 °F (82.2 °C) use a hydraulic end cooler.

All data based on water.

Hydra-Cell® Glossary of Terms

Absolute Pressure (PSIA): The total force per unit area exerted by a fluid. It is the sum of Atmospheric Pressure and Gauge Pressure.

Accuracy: The degree of precision, usually expressed in terms of error, as a percentage of the specified value, or as a percentage of a range. (See separate definition for Steady-state Accuracy, per API 675 Standard, on the following page.)

API 674 Standard: This standard covers the minimum requirements for reciprocating positive displacement pumps for service in the petroleum, chemical, and gas industries. Both direct-acting and power-frame types are included. There are no test requirements defined within API 674 Standard for Steady-state Accuracy, Flow Repeatability, or Linearity.

API 675 Standard: This standard covers the minimum requirements for controlled volume positive displacement pumps for service in the petroleum, chemical, and gas industries. Both packed-plunger and diaphragm types are included. Diaphragm pumps that use direct mechanical actuation are excluded. Hydra-Cell pumps meet and exceed the performance test requirements of API 675 Standard for Steady-state Accuracy, Flow Repeatability, and Linearity (as defined in section 4.3.3); however, they do not meet all design requirements defined in section 2 of the standard.

Atmospheric Pressure:

The force exerted on a unit area by the weight of the atmosphere; the higher the elevation above sea level, the lower the atmospheric pressure, P_{atm} . (See graph on right.)

Cavitation: Process in which small bubbles are formed and implode violently; occurs instantaneously when $NPSH_a < NPSH_r$.

Fluids: Include liquids, gases, and mixtures of liquids, solids and gases. In this catalog, the terms fluid and liquid are both used to mean a pure liquid or a liquid mixed with gases or solids that act essentially like a liquid in pumping applications.

Fluid Slip: Commonly used to describe the migration of liquid around the internal moving parts of a pump. It is the volumetric difference between physical component displacement and liquid throughput of a pump system.

Fluid Slip Loss: Refers to the liquid that passes through the clearance space, ($\sim .00005''$) between the piston and the cylinder wall. The clearance between the piston and cylinder wall must be optimized for the liquid being pumped in order to minimize the loss due to fluid slip.

Head: A measure of pressure expressed in feet of head for centrifugal pumps; indicates the height of a column of water being moved by the pump (without friction losses).

Metering Linearity: The degree to which performance or response approaches the condition of being linear; the maximum deviation from the ideal straight line that can be drawn through plotted calibration test points describing how flow varies with capacity setting. It is expressed as percent (\pm) of the Rated Capacity of the pump. API 675 Standard stipulates that Linearity must remain within $\pm 3\%$. Linearity of $\pm 3\%$ or better can be achieved with Hydra-Cell pumps; it is a function of rated speed, Turndown Ratio, and system operating temperature and pressure ranges.

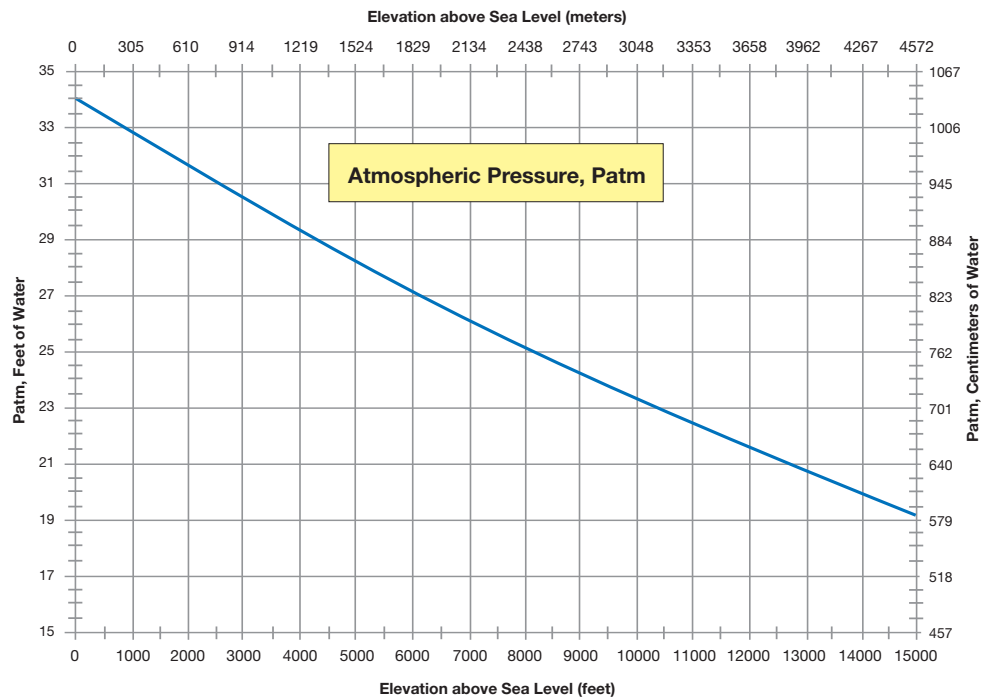

Hydra-Cell® Glossary of Terms

Metering Repeatability: Describes the reproducibility of pump flow rate under a given set of conditions when the capacity setting is varied and then returned to the set point being tested; expressed as a percent (\pm) of rated capacity. API 675 Standard stipulates that repeatability must remain within $\pm 3\%$. Flow Repeatability of $\pm 3\%$ or better can be achieved with Hydra-Cell pumps; it is a function of rated speed, turndown ratio, and system operating temperature and pressure ranges.

Metering Steady-state Accuracy: Flow variation expressed as a percentage of mean delivered flow under fixed system conditions; applies over the Turndown Ratio. API 675 Standard stipulates that Steady-state Accuracy must remain within $\pm 1\%$. Steady-state Accuracy of $\pm 1\%$ for Hydra-Cell P Series metering pumps reflects continuous run, injection-mode metering.

See pages 166 and 167 for graphs depicting Hydra-Cell performance pertaining to the API 675 Standard for Accuracy, Linearity, and Repeatability.

Net Positive Suction Head Available (NPSHa):

The total suction head (in feet or meters absolute) present at the pump suction connection, less the vapor pressure of the pumped liquid (in feet or meters absolute). NPSHa is a function of the system in which the pump operates everything on the suction side of the pump up to the suction port. The formula below is commonly used to determine system NPSHa.

$$NPSHa = P_t + H_z - H_f - H_a - P_{vp}$$

P_t : Atmospheric pressure

H_z : Vertical distance from surface liquid to pump centerline (if liquid is below pump centerline, then H_z is negative)

H_f : Friction loss in suction pumping

H_a : Acceleration head at pump suction

P_{vp} : Absolute vapor pressure of liquid at pumping temperature

Note: It is important to correct for the specific gravity of the liquid and to convert all terms to units of “feet absolute” or “meters absolute” when using this formula.

Net Positive Suction Head Required (NPSHr):

The positive pressure (in feet absolute) required at the pump suction port to overcome pressure losses that occur as the fluid travels from the suction port to the point(s) inside the pump where the pressure starts to increase. NPSHr is a

function of the pump design, size (capacity), and operating speed. It is measured at the suction port of the pump and typically provided by the pump manufacturer in the form of a curve or set of curves.

Note: Testing in water is standard practice; therefore, NPSHr data is generally provided in units of “feet of water.” This must be taken into consideration and converted to “feet of pumped liquid” when comparing to the calculated value of NPSHa.

Prime: Charge of liquid required to begin pumping action when the liquid source is lower than the pump; held in pump by a foot valve on the intake line or by a valve or chamber within the pump.

Rated Capacity: The quantity of fluid actually delivered per unit of time at the maximum operating speed. This quantity can be expressed in units of volume or mass; it includes liquid and any dissolved or entrained gases or solids, and is based on suction conditions.

Specific Gravity: The ratio of the weight of a given volume of liquid to pure water. Pumping heavy liquids (specific gravity greater than 1.0) will require more drive horsepower.

Static Discharge Head: Maximum vertical distance (in feet) from pump to point of discharge with no flow.

Total Head: Sum of discharge head, suction lift, and friction loss.

Turndown Ratio: The Rated Capacity divided by the minimum capacity that can be obtained while maintaining specified Steady-state Accuracy, Flow Repeatability, and Linearity. A 10:1 Turndown Ratio capability is industry standard for metering applications. Use of sophisticated motor controls allows speed Turndown Ratios of 1000:1 and greater if required. The mechanical response of the metering pump over these extremely high Turndown Ratios may or may not meet API 675 Standard testing requirements.

Viscosity: The resistance of a fluid to flow when subjected to shear stress (the “thickness” of a liquid). Most liquids decrease in viscosity and flow more easily as they get warmer. Absolute viscosity is measured in centipoises. Kinematic viscosity includes the influence of the specific gravity of the fluid and is measured in centistokes.

Wanner Engineering - Additional Product Lines

Non-metallic ANSI Centrifugal Pumps Featuring Solid PVDF Pump Heads

STAN-COR



Designed to handle difficult process fluids, Stan-Cor pumps offer total dynamic head to 350 feet and flow rate capacities to 700 gpm (2650 l/min).

Designed to Handle Dirty, Abrasive, Corrosive, and Reclaim Process Fluids

Manufactured in the USA by Wanner Engineering, Stan-Cor pumps provide superior handling of difficult process fluids in a cost-effective, rugged, and durable design. They operate with a smooth, full-curve performance and offer exclusive design advantages compared to other centrifugal pumps.

- Solid PVDF pump head for chemical compatibility and excellent abrasion resistance
- Handles high operating temperatures

- Concentric casing design for better flow patterns than other centrifugal pumps - less turbulence, longer seal life, and reduced shaft deflection
- Compact design features including heavy-duty drive shaft, adjustable bearing supports, and large-capacity oil bath ensure low maintenance as well as durable performance for the toughest fluid applications
- Back pull-out design for easy servicing
- Handles solid sizes up to 9/16" maximum

For more information, contact Wanner Engineering or visit www.StanCorPump.com

Wanner Engineering - Additional Product Lines

Peristaltic Pumps that Isolate the Fluid Being Pumped

VECTOR



Nine 2000 Series Vector pump models offer maximum flow rates from 0.3 gpm (1.1 l/min) to 211 gpm (798.7 l/min) and discharge pressures from 30 psig (2.1 bar) to 116 psig (8 bar) depending on pump model. Model 3005 provides up to 9.2 gpm (34.8 l/min) at 200 psig (13.8 bar).

Seven 4000 Series Vector pump models offer maximum flow rates from 0.79 gpm (3.0 l/min) to 154.1 gpm (583.3 l/min) and discharge pressures of 110 psig (7.6 bar) or 218 psig (15 bar) depending on pump model.

Designed to Handle High-viscosity Fluids, Aggressive and Corrosive Fluids, and High-purity Solutions

Available from Wanner Engineering, Vector pumps can handle pasty, pulp, or thick fluids commonly found in industrial processing applications. They will reliably start, stop, and continuously pump such fluids at a wide range of pressures and flows. The pumping action is powerful, but will not break up delicate emulsions or cause excessive frothing of dissolved gases.

- Dry pump cavity
- Self-priming operation
- Runs dry without damage to the pump
- Complete isolation of the fluid being pumped from contact with mechanical parts for the fluid transport system
- Heavy-duty roller bearings
- Wide range of pump configurations and flow rates
- No cups, packing, or dynamic seals to leak or replace or come in direct contact with the pumped fluid
- Low maintenance
- Reversible flow

For more information, contact Wanner Engineering or visit www.VectorPump.com



Hydra-Cell® Limited Warranty

Wanner Engineering, Inc. (WEI) warrants that, for a period of one (1) year from the date of purchase, equipment supplied or manufactured by WEI shall be free of defects in materials and workmanship under normal use and service, and provided the equipment is installed, operated and maintained in accordance with instructions supplied by WEI.

Notwithstanding anything to the contrary, this limited warranty does not cover:

1. Normal wear and/or damage caused by or related to abrasion, corrosion, abuse, negligence, accident, faulty installation, or tampering which impairs normal operation of the equipment.
2. Electric motors (if applicable) not manufactured by WEI. The warranties, if any, on such equipment are assigned to the Purchaser by WEI (without recourse) at the time of purchase.
3. Transportation costs.

Purchaser's sole and exclusive remedy and WEI's sole liability, whether based upon warranty, contract or tort, including negligence, is limited to WEI's repair or replacement of the defective part, at WEI's sole option.

Any claim regarding breach of warranty must be received by WEI before the expiration of the warranty period and by written notice from Purchaser of such defect within thirty (30) days from the discovery thereof. WEI requires the return to a designated WEI location, of the defective part, transportation prepaid, to establish Purchaser's claim. No allowance will be made for repairs undertaken without WEI's written consent or approval.

WEI's warranty obligations and Purchaser's remedies thereunder are solely and exclusively as stated herein.

There are no other warranties, whether oral, written, express, implied or statutory, including, but not limited to, implied warranties of merchantability and fitness for a particular purpose, warranties of non-infringement, warranties arising from course of dealing or usage of trade or any other matter.

Any descriptions of the equipment drawings, specifications, and any samples, models, bulletins, or similar material used in connection with the sale of equipment are for the sole purpose of identifying the equipment and are not to be construed as an express warranty that the equipment will conform to such description. Any field advisory or installation support is advisory only.

Every form of liability for direct, special, incidental or consequential damages or loss is expressly excluded and denied. All liability of WEI shall terminate one (1) year from the date of purchase of the equipment.

Hydra-Cell® Application Worksheet



www.Hydra-Cell.com

Let us help you determine the best solution for your pumping application. Simply provide the information below, tear out the page, and send it to us.

1. Fax to 612-332-6937 or toll-free (USA) at 800-332-6812
2. Scan the page and email it as an attachment to sales@wannereng.com
3. Mail the page - either in an envelope or fold it, and using the other side as a mailing label, tape the page closed, affix postage and mail it
4. Give it to your local Wanner distributor

Fluid Information:

Fluid Name: _____

Solids: Yes No If Yes, size and percentage: _____

Fluid Temperature: Operating _____ Min _____ Max _____

Viscosity: Min _____ Max _____ Specific Gravity: _____

Please provide a brief description of the application and fluid characteristics (e.g. abrasive, shear-sensitive)

Please provide MSDS Sheet if available.

Equipment Information:

Installation: New Existing

If existing, previous equipment installed: _____

Flow Rate: Operating _____ Min _____ Max _____

Discharge Pressure: _____ Inlet (Suction) Pressure: _____

NPSHa: _____

Inlet Pipe Diameter: _____ Inlet Pipe Length: _____

Supply Voltage: Phase _____ Hertz _____

Contact Information:

Name: _____ Date: _____

Title: _____

Company: _____

Address: _____

City: _____ State/Province: _____ Zip/Postal: _____

Phone: _____ Fax: _____

Email: _____

Company Website: _____

Market/Industry: _____

PLACE
POSTAGE
HERE



Wanner Engineering, Inc.
1204 Chestnut Avenue
Minneapolis, MN 55403 USA

Hydra-Cell® Worldwide Sales and Service



Hydra-Cell pumps are sold and serviced worldwide by a comprehensive network of factory-trained pump distributors. As specialists in pump technologies, our distributor organizations offer you a vital local resource for technical expertise, product training, sales and service.

Hydra-Cell distributors are located in more than 70 countries worldwide. In North America specifically, there are more than 100 Hydra-Cell distributor locations to provide local availability for every major commercial, institutional, industrial, and municipal marketplace.

World Headquarters & Manufacturing

★ Minneapolis, Minnesota, USA

Business Units

- ☀ Wichita Falls, Texas, USA
- ☀ Hampshire, United Kingdom
- ☀ Kowloon, Hong Kong
- ☀ Shanghai, China
- ☀ São Paulo, Brazil

Contact us for the name and location of the authorized Hydra-Cell distributor nearest you:

Algeria	Colombia	India	Mongolia	Russia	Thailand
Argentina	Costa Rica	Indonesia	Morocco	Saudi Arabia	Tunisia
Australia	Czech Republic	Ireland	Netherlands	Serbia	Turkey
Austria	Denmark	Israel	New Zealand	Singapore	Ukraine
Azerbaijan	Ecuador	Italy	Norway	Slovakia	United Arab Emirates
Belarus	Egypt	Japan	Oman	Slovenia	United Kingdom
Belgium	Estonia	Kazakhstan	Panama	South Africa	United States
Bolivia	Finland	Kuwait	Peru	South East Asia	Uruguay
Brazil	France	Latvia	Poland	South Korea	Venezuela
Bulgaria	Germany	Lithuania	Portugal	Spain	Viet Nam
Canada	Greece	Luxembourg	Puerto Rico	Sweden	Yemen
Chile	Hong Kong	Malaysia	Qatar	Switzerland	
China	Hungary	Mexico	Romania	Taiwan	

Hydra-Cell®

Seal-less Pumps

Wanner Engineering, Inc.™

World Headquarters & Manufacturing

Wanner Engineering, Inc.
1204 Chestnut Avenue
Minneapolis, MN 55403 USA
Phone: 612-332-5681 • Fax: 612-332-6937
Toll-Free Fax (USA): 800-332-6812
Email: sales@wannereng.com
www.Hydra-Cell.com

Regional Office

207 US Highway 281
Wichita Falls, TX 76310 USA
Phone: 940-322-7111
Toll-Free: 800-234-1384
Email: sales@wannereng.com
www.Hydra-Cell.com

Latin American Office

Avenida Senador Vergueiro 608 - Centro
São Bernardo do Campo/São Paulo, Brazil
CEP 09750-000
Phone: +55 (11) 99582-1969
Email: mmagoni@wannereng.com
www.Hydra-Cell-Pumps.com.br

Wanner International Ltd.™

Wanner International, Ltd.
Hampshire - United Kingdom
Phone: +44 (0) 1252 816847
Email: sales@wannerint.com
www.Hydra-Cell.co.uk

Wanner Pumps Ltd.™

Wanner Pumps, Ltd.
Kowloon - Hong Kong
Phone: +852 3428 6534
Email: sales@wannerpumps.com
www.WannerPumps.com

Shanghai - China
Phone: +86-21-6876 3700
Email: sales@wannerpumps.com
www.WannerPumps.com

