

---

**Price® Pump Co.**

# **INSTALLATION, OPERATING AND MAINTENANCE MANUAL**

## **TYPE CL CENTRIFUGAL PUMPS**

**MODELS: CL150SS - 56C**

**MODELS: CL150SS - 182/184TC**

**PLEASE FILL IN FROM PUMP NAMEPLATE**

Pump Model \_\_\_\_\_

Spec. No. \_\_\_\_\_

Serial No. \_\_\_\_\_

Price® Pump Company  
2203 Smeed Parkway  
Caldwell, ID 83605  
Tel: 208-402-6871  
Fax 208-402-6856  
Email: sales@pricepump.com

**RETAIN MANUAL FOR REFERENCE**

# Congratulations

You are now the owner of a Price® Pump Co. Centrifugal Pump. This pump was carefully inspected and subjected to final performance tests before being released for shipment. In order to achieve maximum performance and reliability, please follow the simple instructions in this manual.

## RECOMMENDED PRECAUTIONS

1. For satisfactory operation and safety, maximum system pressure must not exceed 350 psi\* (24.6kg/sq cm).
2. For satisfactory operation and safety, maximum fluid temperature must not exceed 300°F\* (121°C).
3. No modifications, additions or deletions should be made to the pump without prior approval of the factory.
4. Drain pump completely and flush with water before servicing a pump handling volatile or harmful liquids.

## READ CAREFULLY THE CAUTION BELOW

The performance of your Price® Pump Co. Centrifugal Pump is based on clean, room temperature, water with suction conditions as shown on the performance curves. If used to pump liquids other than water, pump performance may differ from rated performance based on the different specific gravity, temperature, viscosity, etc. of the liquid being pumped. A standard pump, however, may not be safe for pumping all types of liquids, such as toxic, volatile or chemical liquids, or liquids under extreme temperatures or pressures.

Please consult Price® Pump Co. technical specifications as well as local codes and general references to determine the appropriate pump for your particular application. Since it is impossible for us to anticipate every application of a Price® Centrifugal pump, if you plan to use the pump for a non-water application, contact Price® Pump Co. beforehand to determine whether such application may be appropriate and safe under the operating conditions. Failure to do so could result in property damage or personal harm.

\* Depends on seal materials and seal type

Visit our website for product information and technical support

[www.pricepump.com](http://www.pricepump.com)

# INSTALLATION / OPERATING INSTRUCTIONS

## CENTRIFUGAL PUMPS

### **Warning**

Before installing, repairing or performing maintenance on this pump, read these instructions completely.

Disconnect power to pump before servicing to avoid dangerous or fatal electrical shock.

Match supply voltage and frequency to motor nameplate values. Incorrect voltage can cause fire or serious motor damage and void warranty.

Ground motor before connection to electrical power supply! Failure to ground motor can cause severe or fatal electrical shock!

### **Do not ground to gas supply line!**

Before disassembling pump, be certain all liquid has been removed. If pump was used to pump hazardous or toxic fluid, it must be decontaminated prior to disassembly.

### **Close Coupled Motor Pumps**

It is suggested that these pumps be firmly bolted to a level surface. Adequate air movement around motor will help prevent overheating.

Do not over tighten inlet and outlet piping or volute may be damaged.

### **Power Frame Mounted Pumps**

Power Frame mounted pumps must be mounted on a rigid base that will not warp or flex. Each pump must be mounted such that the pump shaft centerline is in-line with the driver shaft centerline. Pads and/or shims will be required on the pump, the driver or both to insure proper alignment. The two shafts should not touch each other (end to end) and the distance between them depends on the coupling used to connect them.

Misalignment will cause vibration, bearing failure and void warranty. Pumps are rough aligned at the factory

but must be realigned after shipment and installation.

Pulley driven pump must have pulleys inline and proper belt tightness practices followed.

### **Direction of Rotation**

Note: Motor shaft rotation is viewed from the suction end of pump. A rotational arrow is shown on the front of the pump volute casing. Incorrect rotation can cause pump damage, failure or reduced performance, voiding warranty. It is best to check rotation by momentarily energizing or jogging the motor prior to filling pump with liquid.

**Warning!** Do not operate pump without liquid as damage may result to the pump internal wear surfaces.

### **Plumbing**

All piping needs to be supported independently of the pump. Piping connections should not exert any stress on the pump volute or fittings.

# INSTALLATION / OPERATING INSTRUCTIONS

---

## Suction Piping (Inlet)

(Horizontal Pumps)

Suction line must provide adequate suction pressure and even (Laminar) liquid flow for proper pump operation. Air, entrapped in the suction line due to leaks or improper piping design, may cause the pump to lose prime. Non-priming pumps must have their suction 'flooded' at start up (see datasheets for minimum NPSHR). Also, the suction line must provide sufficient pressure (NPSH) and even flow to pump inlet to prevent pump cavitation. The suction pipe entering the pump should be straight and a minimum length of 5 times and preferably 10 times the pump inlet diameter. Elbows, fittings or valves installed close to the pump inlet can disrupt liquid flow and cause cavitation. Suction lines must be at least the same diameter as the pump inlet or larger if possible.

Price Pump Company recommends against using foot valves in the suction line to maintain liquid in the pump when it's not operating. If foot valves are used, due to suction lift conditions, they must be properly maintained to avoid

leaks resulting from wear or fouling. Suction piping must be designed to prevent vapor from being trapped in high spots in the piping. This condition may cause the pump to vapor lock.

## Discharge Piping (Outlet)

To control flow and discharge head, it is advisable to install a valve (globe, ball, or other adjustable and non-leak type) in the discharge line adjacent to the pump. The valve may be closed during system repairs to prevent backflow. By installing a check valve in the discharge line, backflow can also be prevented during maintenance or during periods of pump stoppage.

## Operation

All centrifugal pumps must be filled with liquid prior to start up. It is suggested that during initial start up the discharge valve be closed and then opened as the motor reaches full rpm's. If pump does not build up pressure as motor speed increases, shut down and make sure that liquid flow into pump is not restricted (see "Troubleshooting").

**Note:** A centrifugal pumps flow rate and head (pressure) will vary with the amount of resistance (pipe friction and flow restrictions) in the discharge line. As the valve on the discharge line opens, the flow rate and motor amperes draw will increase and head (pressure) will decrease. As the valve on the discharge line is closed, the flow rate and amperes draw will decrease and the head (pressure) will increase.

If resistance in the discharge line is not sufficient, the pump will operate at a condition of maximum flow, sometimes called "end of curve" performance. Maximum horse-power is required to operate at this point and motor overload may result. If excessive amperes draw and motor overload is occurring, reduce the system flow rate by installing a valve or orifice in the discharge line to control (restrict) the pumps flow rate. Alternatively, reduce pump head by trimming impeller to a smaller diameter.

Consult Price Pump or a local Price Pump distributor for assistance.

[www.appsupport@pricepump.com](mailto:www.appsupport@pricepump.com)

# INSTALLATION / OPERATING INSTRUCTIONS

---

## INSTALLING A PEO (PUMP END ONLY) STUB SHAFT PUMP

- a. Place the bracket on a firm surface, loosen stub shaft setscrews and carefully remove shipping plug.
- b. Place motor in an upright position with motor shaft pointing upward. Make sure motor shaft and end bell flange are free of burrs and surfaces are clean.
- c. Align PEO stub shaft setscrews (if applicable) with motor shaft keyway and carefully slid the PEO onto the motor shaft until it sits firmly onto the motor end bell flange.
- d. Oriented the PEO's discharge port or base to preferred motor configuration while referencing the motors electrical box position.
- e. Install flange bolts and tighten. (Install pump base if applicable)
- f. Reposition pump back onto motor base.
- g. Refer to pump Reassembly Instructions and proceed to **setting the impeller clearance** (if applicable).

## INSTALLING A PEO (PUMP END ONLY) NON-STUB SHAFT PUMP

- a. Carefully un-pack all components received with your shipment and remove any shipping plugs.
- b. Place the bracket on a firm surface with the seat cavity (pump end) up. Follow seal Installation / reassembly instructions contained within this manual.
- c. Make sure motor shaft and motor end bell flange are free of burrs and surfaces are clean.
- d. Carefully place the Bracket assembly over the motor shaft and align bracket with motor end bell flange.
- e. Install impeller, gasket or o-ring, volute and volute mounting bolts.
- f. Oriented the PEO's discharge port or base to preferred motor configuration while referencing the motors electrical box position.
- g. Install motor flange bolts and tighten all bolts to proper torque. (Install pump base if applicable)

# TROUBLESHOOTING

---

## 1. Pump fails to build head pressure:

Check for:

- a. Pump not primed.
- b. Incorrect pump rotation.
- c. Driver speed too low.
- d. Suction line restricted.
- e. Driver failure.
- f. Plugged or damaged impeller.
- g. Pump or impeller undersized.
- h. Pump cavitation.
- i. Improper impeller clearance.

## 2. Pump fails to provide enough flow rate.

Check for:

- a. System resistance too high.
- b. Pump undersized.
- c. Pump not primed.
- d. Driver speed too low.
- e. Poor suction conditions.
- f. Improper impeller clearance.

## 3. Excessive noise or vibration during operation.

Check for:

- a. Motor bearing failing.
- b. Pump cavitation.
- c. Improper impeller clearance.

## 4. Leaking mechanical seal.

Check for:

- a. Improper assembly.
- b. Worn or cracked seal faces.
- c. Abrasive material in fluid.
- d. Liquid flashing at seal faces (Fluid temperature too high).
- e. Seal pressure rating too low for the service.
- f. Chemical attack of seal components.
- g. Seal operated dry or with a liquid having poor lubricating properties.

## 5. Pump gradually loses pressure and head.

Check for:

- a. Increasing temperature causing cavitation or liquid vaporization.
- b. Driver failure.
- c. Suction lift too high.
- d. Air entering suction line.

## 6. Motor overheating.

Check for:

- a. Excessive flow and amp draw (Throttle discharge).
- b. Low voltage or frequency.
- c. Flow rate too low with resulting heat rise.
- d. Bearing failure.
- e. System temperature too high.

## 7. Decoupling. (Mag drives only)

Check for:

- a. Excessive starting torque.

**NOTE:** Magnet drive pumps, above 3 HP, require a variable Frequency Drive (VFD) or soft starter.

- b. System resistance too high .
- c. Pump not primed .

# REPAIR AND MAINTENANCE

---

Before attempting any repairs under warranty, contact Price Pump to obtain factory authorization. Repairs carried out without authorization may void warranty. Many causes of pump failure are due to improper system design. Refer to the trouble shooting list in this manual before carrying out pump inspection or repair.

## DISASSEMBLY

1. Disconnect power source from motor.
2. Disconnect electrical connections, tagging wires carefully to preserve correct rotation. Loosen pump base.
3. Remove pump and motor assembly to repair area. Observe position of all parts prior to disassembly.
4. Remove six volute bolts and remove volute from pump.
5. Remove impeller set screws. Slide impeller off of the motor shaft.
6. Remove seal head from the impeller by sliding it off of the hub.
7. Remove the four motor bolts and remove the bracket from motor.
8. Remove the seal seat from the bracket. Use wooden or plastic dowel to tap the seat from the bracket.

## REASSEMBLY

1. Thoroughly clean the motor shaft. Make sure that the shaft and keyway have no burrs. Polish the shaft with extra fine emery cloth (or equivalent) and clean the keyway.
2. Clean seal cavity in the bracket thoroughly. Place the bracket on a firm surface with the seat cavity (pump end) up. Place a small amount of vegetable oil (or equivalent)

on the seat cup or O-ring seat. Place the seat in the seal cavity with the polished face up towards the pump end. Evenly push the seat into the seat cavity using your fingers, and then gently tap the seat into place with a plastic or wooden dowel.

3. With motor resting on flat surface, shaft end up, carefully place the bracket on the motor. Secure the bracket to the motor with four motor bolts.
4. Thoroughly clean and inspect the outer diameter of the impeller hub. Install rotary seal head onto the impeller hub with the carbon facing away from the impeller. Using a twisting motion, slide the seal head all the way up to the step of the impeller hub.
5. Thoroughly clean and inspect inner diameter of the impeller hub. Carefully slide the impeller onto the motor shaft and through the center of the ceramic seat until the faces are touching and the seal spring is fully compressed. Tighten one of the impeller hub set screws just enough so that the impeller does not move forward. For Type 9 Mechanical seal, see Assembly procedure for Type 9 Mechanical seal for CL150.
6. Insert new volute O-ring (or gasket). Ensure that all of the mating surfaces of the O-ring (or gasket) joint are cleaned.

7. Mount volute to bracket and secure with six volute bolts; tighten evenly.

8. Loosen impeller set screw. The impeller should come forward until the vanes touch the inner volute surface.
9. With setting tool, feeler gauge, or other method, move the impeller **.010"** - **.015"** back from the volute face. Evenly tighten impeller hub set screws.

**Manually rotate impeller to ensure impeller does not rub against the volute.**

10. Re-install pump in installation. Reconnect electrical connections.
11. Remove top pipe plug from the front of the volute and prime thoroughly, making sure all air is purged.
12. Start pump momentarily to observe shaft rotation. If rotation corresponds to the rotation arrow, pump may be put into service. If rotation is incorrect, switch any two leads on 3-phase motors; check motor wiring diagram for single phase rotation.
13. Start pump allowing adequate time to purge all air from the system. Observe any gauges, flow meters, etc. to see if the pump is performing properly.

### **Assembly Procedure for TYPE 9 Mechanical Seal for CL150**

- a) Place the bracket on a firm surface with the seal counter bore (pump end) facing upward. Install stationary seat pin into the drilled hole of the bracket's seal counter bore. Pin height when installed .10"
- b) Rub a small amount of seal lubricant onto the seat cup or O -ring. Align the notch in the back side of the stationary seat with the seat pin in the seal counter bore and firmly press the stationary seat evenly with your fingers into place. Make sure the stationary seal seat is seated into the bottom of the counter bore.
- c) Insure stationary seat face is clean and free of lubricant after installation. Use tissue if necessary.
- d) Assemble bracket to motor.
- e) Remove impeller set screws.
- f) Slide seal cartridge head onto impeller hub. Carbon seal face should be facing outward.
- g) Carefully remove retaining clips and discard.
- h) Slide cartridge on further until it contacts the back shoulder of the impeller shroud.
- i) Tighten the four seal cartridge set screws evenly.
- j) Reinstall the impeller setscrews.
- k) Carefully align impeller to motor shaft and install impeller.
- l) Continue on to # 5 of reassembly instructions.



# REPAIR AND MAINTENANCE

---

THIS PAGE INTENTIONALLY LEFT BLANK



# CL150SS Parts List

**PRICE PUMP CO.**

CL150SS plist.doc rev. 2

<b>Key #</b>	<b>Description</b>	<b>Quantity</b>	<b>316SS</b>
A.	Impeller w/ setscrews	1	
	For 56C motors		3676-dia
	For 143/145TC motors		3677-dia
B.	Volute	1	3503-0
C.	Volute Bolts	6	0917
D.	1/8" Pipe Plugs	3	0559
E.	Bracket	1	3673
F.	Motor Base Plate	1	0197
G.	O-ring	1	
	Viton (std.)		0865
	Teflon (opt.)		0866
	EPR (opt.)		0867
	Buna (opt.)		0868
	Neoprene (opt.)		0869
H <sup>1</sup> .	T.21 Seal / Seat, Viton (std.)	1	0122
H <sup>2</sup> .	T.9 Teflon (opt.)	1	0123
J.	Motor Bolts, top	2	0673
K.	Motor Bolts, bottom	2	0593
N.	Motor	1	Specify P/N
P.	Power Frame	1	5478



**PRICE PUMP CO.**

CL150SS\_P.dwg rev. 2

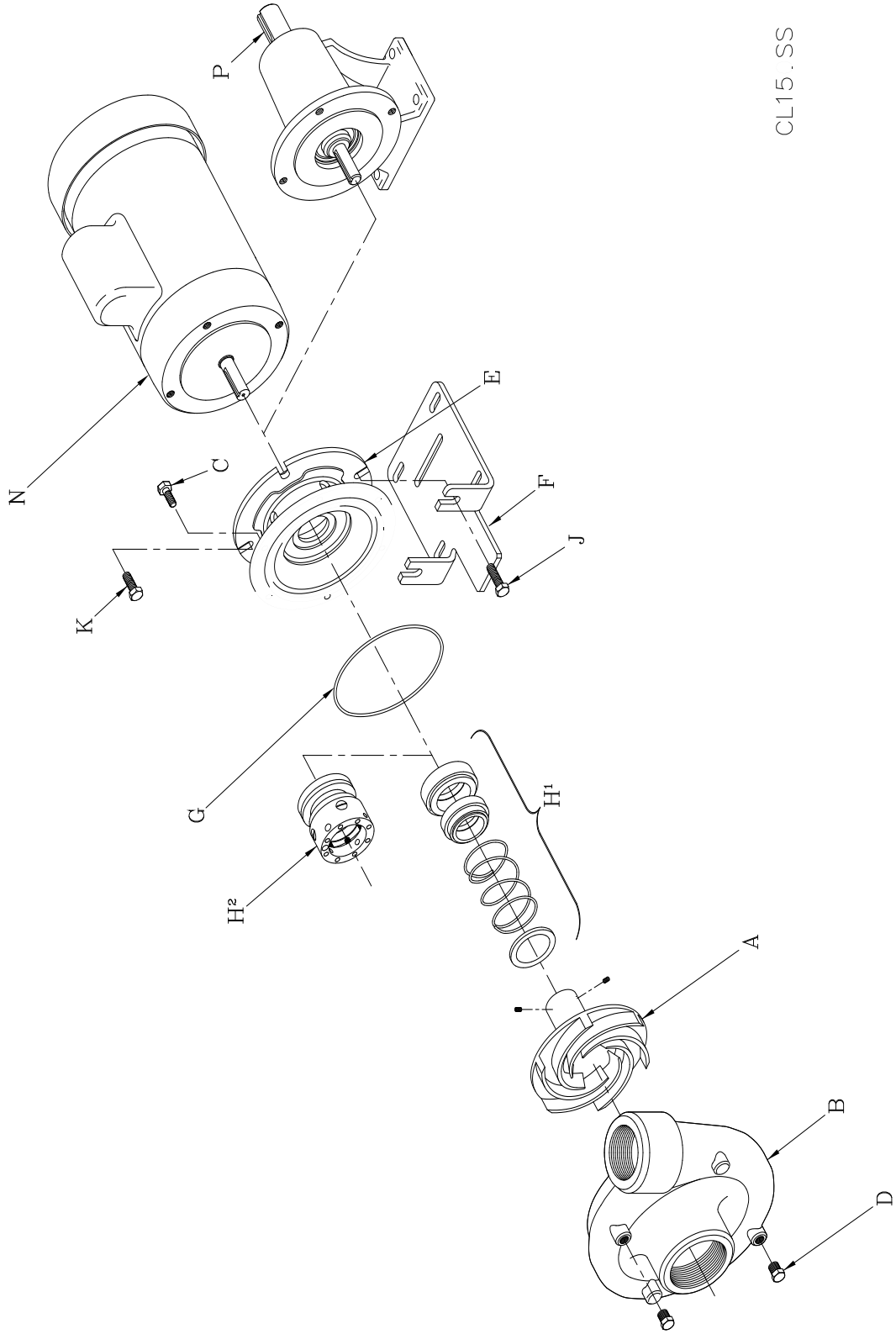

CL15 . SS

Price<sup>®</sup> Pump C...  
2203 Smeed Parkway \* Caldwell, ID 83605 \* (208) 402-6871 \* Fax (208) 402-6856



## CL150SS Parts List (182/184TC)

**PRICE PUMP CO.**

CL150SS (182/184TC) plist.doc rev. C

<b>Key #</b>	<b>Description</b>	<b>Quantity</b>	<b>316SS</b>
A.	Bracket	1	3501
B.	Impeller w/ set screws	1	3502-dia
C.	Volute	1	3503-0
D.	1/8" Pipe Plugs	3	0559
E.	O-ring	1	
	Viton (std.)		0865
	Teflon (opt.)		0866
	EPR (opt.)		0867
	Buna (opt.)		0868
	Neoprene (opt.)		0869
F.	Volute bolt	6	0917
G <sup>1</sup> .	T.21 Seal / Seat, Viton (std.)	1	3516
G <sup>2</sup> .	T.9 Seal / Seat, Teflon (opt.)	1	3567
H.	Motor	1	Specify P/N
I.	Washer	4	1199
J.	Motor bolt	4	1189



PRICE PUMP CO.

CL150SS\_182\_184TC\_P.dwg rev. C

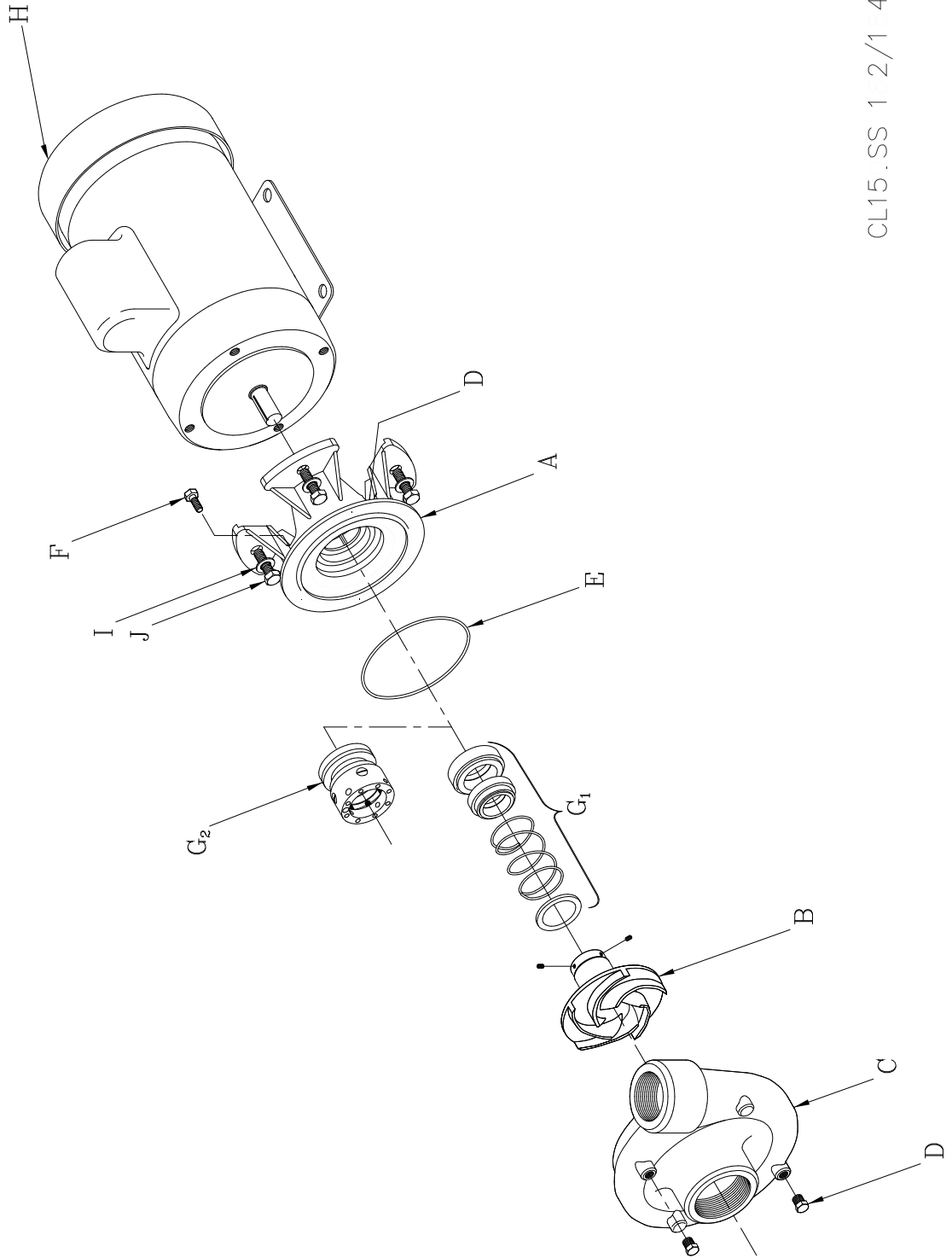

CL15.SS 1 2/1 4TC

## PRICE CENTRIFUGAL PUMP CAUTIONS & WARNINGS

- **CAUTION:** Price Pump centrifugal pumps must be operated above minimum flow rate to avoid damage .
- **CAUTION:** All Price Pump centrifugal pumps require the suction to be flooded .
- **CAUTION:** It is recommended that all piping connections to the pump be flexible.
- **WARNING:** Verify chemical compatibility of the pump materials of construction with the fluid being pumped.
- **WARNING:** Price Pump centrifugal pumps are not designed for use in sanitary or food applications.
- **CAUTION:** Use only Price Pump original equipment factory replacement parts.
- **WARNING:** Price Pump fluid temperature limits must be observed. Maximum operating temperature is 300°F.
- **CAUTION:** The pump should be thoroughly flushed and drained before disassembly.
- **CAUTION:** For larger pump motor units, weight may exceed 65 lbs. (30 kg).
- **CAUTION:** Price Pump Magnet Driven pumps above 3Hp require a VFD or soft starter.

### CAUTION: Maximum solid size by pump

#### Shaft Seal pumps

○ HP75 / MS50	<b>0.030"</b> (0.76mm)
○ SP150	<b>0.060"</b> (1.50mm)
○ LT25	<b>0.120"</b> (3.05mm)
○ F50/75/95	<b>0.150"</b> (3.81mm)
○ OH75	<b>0.150"</b> (3.81mm)
○ CD100/150	<b>0.150"</b> (3.81mm)
○ CL150	<b>0.150"</b> (3.81mm)
○ RC200/300	<b>0.380"</b> (9.60mm)
○ XJ-JB100	<b>0.120"</b> (3.05mm)
○ XJ-JB150	<b>0.250"</b> (6.40mm)
○ XJ-JB200	<b>0.440"</b> (11.2mm)
○ XJ400	<b>0.440"</b> (11.2mm)
○ XL-XT100	<b>0.120"</b> (3.05mm)
○ XL-XT150	<b>0.250"</b> (6.40mm)
○ XL-XT200	<b>0.440"</b> (11.2mm)

#### Magnet Driven pumps

○ HP75MD	<b>0.030"</b> (0.76mm)
○ MS50MD	<b>0.030"</b> (0.76mm)
○ CD100MD	<b>0.060"</b> (1.50mm)
○ CD150MD	<b>0.060"</b> (1.50mm)
○ CL150MD	<b>0.060"</b> (1.50mm)
○ XL-XT100MD	<b>0.060"</b> (1.50mm)
○ XL-XT150MD	<b>0.060"</b> (1.50mm)
○ XL-XT200MD	<b>0.060"</b> (1.50mm)

### CAUTION: Minimum flow rate by pump

○ HP75 / MS50	<b>0.5 GPM</b> (1.9 LPM)
○ SP150	<b>10 GPM</b> (38 LPM)
○ LT25	<b>0.5 GPM</b> (1.9 LPM)
○ F50/75/95	<b>5.0 GPM</b> (19 LPM)
○ OH75	<b>7.0 GPM</b> (26 LPM)
○ CD100	<b>12 GPM</b> (45 LPM)
○ CD150	<b>25 GPM</b> (94 LPM)
○ CL150	<b>40 GPM</b> (150 LPM)
○ RC200	<b>10 GPM</b> (38 LPM)
○ RC300	<b>50 GPM</b> (189 LPM)
○ XJ-JB150	<b>20 GPM</b> (75 LPM)
○ XJ-JB150	<b>40 GPM</b> (150 LPM)
○ XJ-JB200	<b>90 GPM</b> (340 LPM)
○ XJ400	<b>100 GPM</b> (378 LPM)
○ XL-XT100	<b>10 GPM</b> (38 LPM)
○ XL-XT150	<b>35 GPM</b> (132 LPM)
○ XL-XT200	<b>50 GPM</b> (189 LPM)

### CAUTION: Maximum working pressure for seals:

○ Type 02 Seal	<b>350 PSI</b> (24.1 bar)
○ Type 6 Seal	<b>75 PSI</b> (5.2 bar)
○ Type 6A Seal	<b>75 PSI</b> (5.2 bar)
○ Type 8 Seal	<b>325 PSI</b> (22.4 bar)
○ Type 8B Seal	<b>350 PSI</b> (24.1 bar)
○ Type 9 Seal	<b>350 PSI</b> (24.1 bar)
○ Type 21 Seal	<b>150 PSI</b> (10.3 bar)
○ Type 2106 Seal	<b>150 PSI</b> (10.3 bar)
○ Type 36 Seal	<b>75 PSI</b> (5.2 bar)



# GENERAL TERMS OF SALE FOR PRODUCTS

## 1. GENERAL

A. Seller's price is based on these sales terms and conditions. The agreement and inclusion of other or amended terms in this contract will result in a change (including increase) in Seller's price (as may be contained in any price books or quotations) to reflect such other or amended terms. This contract shall represent the final, complete and exclusive statement of the agreement between the parties and may not be modified, supplemented, explained or waived by parole evidence, any Terms and Conditions contained in Buyer's purchase order or request for quotation, any course of dealings between the parties, Seller's performance or delivery, or in any other way. The Terms and Conditions of this contract may only be modified or waived in a written document signed by an Officer of Seller. These terms are intended to cover all activity of Seller and Buyer hereunder, including sales and use of products, parts and work and all related matters (references to products include parts and references to work include construction, installation and start-up). Any reference by Seller to Buyer's specifications and similar requirements are only to describe the products and work covered hereby and no warranties or other terms therein shall have any force of effect. Any information provided by Seller including, but not limited to, suggestions as to specific equipment does not imply any guarantee of specific suitability and/or material compatibility in a particular application, since many factors outside the control of Seller may affect the suitability of products in a particular application. Catalogs, circulars, similar pamphlets and information contained on websites of the Seller are issued for general information purposes only and shall not be deemed to modify the provisions hereof.

B. The agreement formed hereby and the language herein shall be construed and enforced under the Uniform Commercial Code as in effect in the State of California on the date hereof.

## 2. TAXES

Any sales, use or other similar type taxes imposed on this sale or on this transaction and/or any import or export duties or fees as may be assessed or imposed on or as a result of deliveries under this transaction are not included in the price. Such taxes shall be billed separately to the Buyer. Seller will accept a valid exemption certificate from the Buyer if applicable; however, if an exemption certificate previously accepted is not recognized by the governmental taxing authority involved and the Seller is required to pay the tax covered by such exemption certificate. Buyer agrees to promptly reimburse Seller for the taxes paid.

## 3. PERFORMANCE, INSPECTION AND ACCEPTANCE

A. Unless Seller specifically assumes installation, construction or start-up responsibility, all products shall be finally inspected and accepted within thirty (30) days after arrival at point of delivery. Where seller has responsibility for installation, construction or start-up all work shall be finally inspected and accepted with thirty (30) days after completion of the applicable work by Seller. All claims whatsoever by Buyer, (including claims for shortages) except only those provided for under the WARRANTY AND LIMITATION OF LIABILITY and PATENTS Clauses, hereof, must be asserted in writing by Buyer within said thirty (30) day period or they are waived. If this contract involves partial performance, all such claims must be asserted within said thirty (30) day period for each partial performance. There shall be no revocation of acceptance. Rejection may be only for defects substantially impairing the value of products or work and Buyer's remedy for lesser defects shall be those provided for under the WARRANTY AND LIMITATION OF LIABILITY Clause.

B. Seller shall not be responsible for non-performance or for delays in performance occasioned by any causes beyond Seller's reasonable control, including, by way of example and not limitation, to labor difficulties, delays of vendors or carriers, fires, governmental actions, or shortages of material, components, labor, or manufacturing facilities. Any delays so occasioned shall affect a corresponding extension of Seller's performance dates, which are, in any event, understood to be approximate. IN NO EVENT SHALL BUYER BE ENTITLED TO INCIDENTAL OR CONSEQUENTIAL DAMAGES FOR LATE PERFORMANCE OR FOR A FAILURE TO PERFORM. Seller reserves the right to make partial shipments and to ship products, parts or work which may be completed prior to the scheduled performance date.

C. In the event that Seller has agreed to mount motors, turbines, gears, or other products which are not manufactured by Seller and which are not an integral part of Seller's manufactured product, and a delay in the delivery of such products to Seller occurs that will cause a delay in Seller's performance date, Seller reserves the right to ship its product upon completion of manufacture and to refund an equitable portion of the amount originally included in the purchase price for mounting without incurring liability for non-performance.

D. Seller reserves to itself the right to change its specifications, drawings and standards if such changes will not impair the performance of its products, and parts, and further those products, and parts, will meet any of Buyer's specifications and other specific product requirements which are a part of this agreement. Seller is a global supplier of products and utilizes parts and products obtained worldwide, and Seller's products supplied under this contract shall be subject to Seller's sole determination as to all manufacturing, sourcing, assembly and supply unless otherwise specifically agreed in writing.

E. The manufacture and inspection of products and parts shall be to Seller's Engineering and Quality Assurance standards, plus such other inspections or tests of documentation as are specifically agreed to by Seller. Requirements for any additional inspection, tests, documentation, or Buyer witness of manufacture, test, and/or inspection shall be subject to additional charges.

## 4. TITLE AND RISK OF LOSS

Title and risk of loss shall pass to buyer upon delivery of products at the designated "Ex Works" as defined by Incoterms, unless otherwise agreed by the parties.

## 5. EROSION AND CORROSION

It is specifically understood that products and parts sold hereunder are not warranted for operation with erosive or corrosive fluids or for operation with any fluid or under any operating condition in variance with the specifications of this contract. No product or part shall be deemed to be defective by reason of failure to resist erosive or corrosive action of any fluid and Buyer shall have no claim whatsoever against Seller therefore. No product shall be deemed defective by reason of any effect on Seller's products of the action or results (such as vibration) of any goods or system (such as piping) not supplied by Seller.

## 6. BUYER'S RESPONSIBILITY

The design specifications of the equipment require the operation of the equipment within certain parameters and may call for the use of speed controls, safety devices, set points or other control devices to insure that the operation remains within design parameters. Buyer agrees and understands that the equipment must be operated and maintained within design specifications and operated within the specifications of the contract, irrespective of whether controls or devices are otherwise required.

## 7. WARRANTY AND LIMITATION OF LIABILITY.

A. Seller warrants only that its product and parts, when shipped, will be free from defects in materials and workmanship. All claims for defective products or parts under this warranty must be made in writing immediately upon discovery and, in any event, within two (2) years of shipment by seller and all claims for defective work must be made in writing immediately upon discovery. Defective items must be held for Seller's inspection and returned to the seller's point of original shipment upon request.

ANY UNAUTHORIZED DISSASSEMBLY, ALTERATION OF OR TAMPERING WITH ANY PRODUCT OR COMPONENT MAY "VOID" THE WARRANTY, IN THAT SUCH ACTION WILL RESULT IN SELLER BEING RELEASED AND RELIEVED FROM ITS OBLIGATIONS UNDER THIS WARRANTY AND FOR ANY FURTHER COSTS OR ACTIONS UNDER CLAUSE 7.C, FOLLOWING, AND THE BUYER ASSUMING SOLE RESPONSIBILITY FOR THE COSTS AND RESULTS OF SUCH ACTION. THE FOREGOING IS EXPRESSLY IN LIEU OF ALL OTHER WARRANTIES WHATSOEVER, EXPRESS, IMPLIED AND STATUTORY, INCLUDING WITHOUT LIMITATION, THE IMPLIED, WARRANTIES OF MERCHANTABILITY AND FITNESS.

B. ANY PRODUCT (S) SOLD HEREUNDER WHICH ARE NOT MANUFACTURED BY SELLER ARE NOT WARRANTED BY SELLER and shall be covered only by the express warranty, if any, of the manufacturer thereof. With respect to products and parts not manufactured by Seller, Seller's only obligation shall be to assign to Buyer, to the extent possible, whatever warranty Seller obtains from the manufacturer.

C. Upon Buyer's submission of a claim as provided above and its substantiation, Seller shall at its option either (i) repair or replace its product, part or work at the original place of shipment, or (ii) refund an equitable portion of the purchase price.

D. THE FOREGOING IS SELLER'S ONLY OBLIGATION AND BUYER'S EXCLUSIVE REMEDY FOR BREACH OF WARRANTY AND, EXCEPT FOR THE REMEDIES PERMITTED UNDER THE PERFORMANCE, INSPECTION AND ACCEPTANCE AND THE PATENTS CLAUSES HEREOF, THE FOREGOING IS BUYER EXCLUSIVE REMEDY AGAINST SELLER FOR ALL CLAIMS ARISING HEREUNDER OR RELATING HERETO WHETHER SUCH CLAIMS ARE BASED ON BREACH OF CONTRACT, TORT (INCLUDING NEGLIGENCE OR STRICT LIABILITY), INDEMNITY OR OTHER THEORIES. BUYER'S FAILURE TO SUBMIT A CLAIM AS PROVIDED ABOVE SHALL SPECIFICALLY WAIVE ALL CLAIMS FOR DAMAGES OR OTHER RELIEF, INCLUDING BUT NOT LIMITED TO CLAIMS BASED ON LATENT DEFECTS. IN NO EVENT SHALL BUYER BE ENTITLED TO INDIRECT, SPECIAL, INCIDENTAL OR CONSEQUENTIAL DAMAGES, NOR FOR DAMAGES FOR LOSS OF USE, LOST PROFITS OR REVENUE, INTEREST, LOST GOODWILL, WORK OR PRODUCTION STOPPAGE, IMPAIRMENT OF OTHER GOODS, INCREASED EXPENSES OF OPERATION, OR THE COST OF PURCHASING REPLACEMENT POWER OR OTHER SERVICES BECAUSE OF SERVICE INTERRUPTIONS. FURTHERMORE, IN NO EVENT SHALL SELLER'S TOTAL LIABILITY FOR DAMAGES OF BUYER EXCEED THE PURCHASE PRICE OF THE PRODUCTS OR PARTS MANUFACTURED BY SELLER AND UPON WHICH SUCH LIABILITY IS BASED. ANY ACTION ARISING HEREUNDER RELATED HERETO, WHETHER BASED ON BREACH OF CONTRACT, TORT (INCLUDING NEGLIGENCE) OR OTHER THEORIES, MUST BE COMMENCED WITHIN ONE (1) YEAR AFTER THE CAUSE OF ACTION ACCRUES OR IT SHALL BE BARRED.

## 8. PURCHASER'S REPRESENTATIONS & WARRANTIES

Purchaser represents and warrants that the product(s) covered by this contract shall not be used in or in connection with a nuclear facility or application. The parties agree that this representation and warranty is material and is being relied on by seller. This provision may be modified in a separate writing signed by an officer of Price Pump Co.

## 9. PATENTS

Seller agrees to assume the defense of any suit for infringement of any patents brought against Buyer to the extent of such suit charges infringement of an apparatus or product claim by Seller's product in and of itself, provided (i) said product is built entirely to Seller's design, (ii) Buyer notifies Seller in writing of the filing of such suit within ten (10) days after the service of process thereof, and (iii) Seller is given complete control of the defense of such suit, including the right to defend, settle and make changes in the product for the purpose of avoiding infringement of any process or method claims. Provided however, Seller will not defend any suit for infringement of a claimed patent where such alleged infringement is the result of following specific instruction furnished by Seller.

## 10. EXTENT OF SUPPLY

Only products as listed in Seller's proposal are included in this agreement. It must not be assumed that Seller has included anything beyond same.

## 11. MANUFACTURING SOURCES

To maintain delivery schedules, Seller reserves the right to have all or any part of the Buyer's order manufactured at any of Seller's, seller's licensees or sub contractors' plants, globally.

## 12. TERMS OF PAYMENT

Net 30 days from date of invoice.

## 13. ARBITRATION

In the event a dispute arises between the parties relating to or arising out of this agreement, the parties agree to attempt to have their senior management amicably settle the matter. In the event that the matter cannot be settled, the parties shall submit all disputes relating to this Agreement (whether contract, tort, products liability or otherwise) to binding Arbitration before a panel of arbitrators under the Commercial Dispute Resolution Procedures of the American Arbitration Association. Each party shall appoint an arbitrator and the third shall be selected in accordance with the rules of the American Arbitration Association. Judgment upon the award may be entered in any court having jurisdiction. The parties shall cooperate in providing reasonable disclosure of relevant documents. Each party shall bear its own expenses, and the costs and fees of the arbitration shall be borne as allocated by the Arbitrator.