

CATALOG | AUGUST 2023

Low Voltage NEMA Motors

Horizontal and vertical induction motors

Motor type GP, SD, XP, DP
Selection and Pricing Catalog

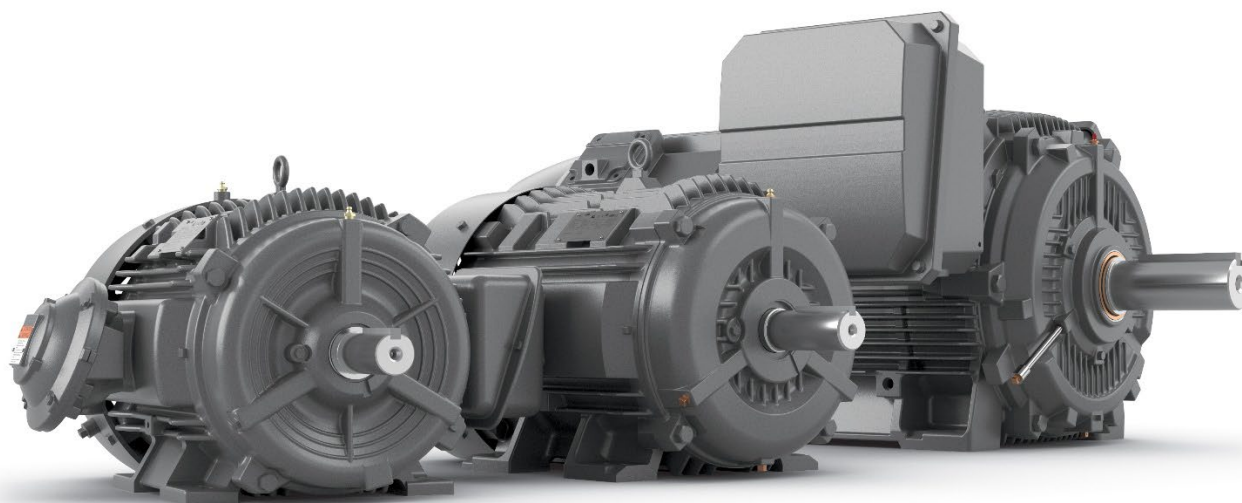

Licensed Motors have NEMA Premium® on their Nameplate

Buy with confidence

Buying a motor can be a difficult process. Is it the right size for the application? Is it the right design? Is it going to last? Is it going to perform to its specifications? Will it meet efficiency claims? The last question is easy to answer if NEMA Premium is on the label.

NEMA Premium Licensees meet a higher standard

All motor manufacturers are required to submit efficiency test data to the US Department of Energy to receive their Certificate of Compliance. Data must be compiled at any qualified testing facility, including the manufacturer's own test laboratory. It takes extra to wear the NEMA Premium label. A NEMA Premium Licensee has agreed to go beyond minimum US DOE requirements.

NEMA Premium Licensees must prove efficiency claims

What is on the nameplate is not what you always get when it comes to efficiency. Most manufacturers will attempt to ship what is on the nameplate, but do not always deliver. If you want assurance that a motor meets its efficiency claims, look for a NEMA Premium certified motor.

NEMA Premium Licensees must submit to third-party testing

NEMA Premium Licensees are required to ship randomly selected motors from distributors' inventory to a third-party qualified laboratory for efficiency verification testing on a regular schedule.

You can buy with confidence when NEMA Premium is on the nameplate.

Table of Contents

- 1. Introduction.....4
- 2. Next Generation Low Voltage NEMA Motors..... 11
- 3. Low Voltage NEMA Motors..... 74
- 4. Technical Tables 187
- 5. Drawings and Dimensions..... 223
- 6. Indexes282

1. Introduction

General information regarding the range of motor, efficiency, warranty, cancellation, and tools

- 1.1. **Wide selection of motors**.....5
- 1.2. **Electric motor energy efficiency**.....7
- 1.3. **Warranty and support**8
- 1.4. **Cancellation charges and change notices**10

1.1. Wide selection of motors

Wide selection

Providing value also means having the right motor for the job. At ABB, we strive to offer a wide variety of motor types, in all frame sizes and power ratings with a comprehensive set of options and quick modifications.

Our ABB NEMA motor portfolio consists of motors with power ratings of 1HP up to 800HP with a variety of voltages up to 600V, stocked to meet the needs of the North American market.

Need a motor for a special project? ABB has that covered as well with a wide selection of modification and custom options available and a highly skilled quotation team to help ensure that the best selection for the job is offered.

Our highly qualified research and development group is working to add to this selection as part of our commitment to become your single source for motors.

The world's most energy efficient line of motors

Lower your energy costs today with the world's most energy efficient line of motors. New regulatory standards and rising energy costs create increasing pressure to maximize energy efficiency and reduce your carbon footprint.

To meet your cost of ownership and motor management needs, ABB offers several levels of energy efficiency in many of its low voltage NEMA motors:

- NEMA Premium® (MG1 Table 12-12)
- NEMA Super Premium® (IE4)

Total customer support

ABB is known as a global leader in technology who offers outstanding collaboration with partners and ensures the success of customers. A dedicated sales force with in-depth product knowledge and training is only a phone call away, and they are available customers with a complete solution. Dedicated Application and Project Support teams have the customers' best interest in mind while reviewing technical content and offering competitive quotations.

The ABB NEMA Motors Order Management team focuses on and takes great pride in putting customers first. Fielding questions, providing order status updates, and expediting shipments are just a few examples of this team's expertise and support.

Availability

ABB has hundreds of distributor stocking locations throughout North America with a wide selection of low voltage NEMA frame sizes and ratings. Motors are available same day from a local source you can trust.

Need something special? Our modification centers have complete motor modification capabilities to help you get the exact motor you need when you need it.

Iron-clad quality

The quality of our motors begins with our more than 100 years of design experience. We build on this experience every day with new designs that incorporate the latest materials and techniques to provide even higher levels of performance, operating efficiency, and reliability.

These advanced motor designs are manufactured in a state-of-the-art, ISO 9001 certified facility. Here, our manufacturing technicians subject each motor to more than 100 separate quality inspections before it leaves our plant, ensuring it meets the high standards our customers expect.

1.2. Electric motor energy efficiency

U.S. Dept. of Energy Integral Horsepower Motor Rule Effective June 1, 2016

The United States Department of Energy passed a final rule in 2014 that covers 1-500 HP (0.75 – 370 kW) 3-phase electric motors. The new law superseded the Energy Independence & Security Act (EISA) of 2007 and became effective June 1, 2016. For reference and complete wording of the law, refer to:

<https://www.regulations.gov/document?D=EERE-2010-BT-STD-0027-0117>.

The most recent legislation broadens the number of motor types covered and closes most of the loopholes that permitted exceptions in both EAct 1992 and EISA 2007 legislation. In essence, most 3-phase industrial motors manufactured are now required to meet the efficiencies listed in NEMA MG-1, table 12-12 (reference NEMA Premium® efficiency).

Additional motor types covered include, but are not limited to:

- 200-500 HP (previously 1- 200 HP)
- Footless (C-face & D-flange)
- Vertical (HP & LP)
- 8-pole (900 RPM)
- Brake motors (integral and add-on)
- Motors with customer special shafts, flanges, and mountings

Motors that are not covered by mandated efficiency regulations are:

- Multi-speed
- Inverter duty only

1.3. Warranty and support

ABB Low Voltage NEMA Motors

Warranty procedure

Standard terms and conditions of sale

ABB (“Company”) warrants that on the date of shipment to purchaser the goods will be of the kind and quality described herein, merchantable, and free of defects in workmanship and material.

If within one year from date of operation, but not more than eighteen months from date of shipment by Company, of any item of the goods, purchaser discovers that such item was not as warranted above and promptly notifies Company in written thereof, Company shall remedy such defect by, at Company's option, adjustment, repair, or replacement of the item and any affected part of the goods.

The purchaser shall assume all responsibility and expense for removal, reinstallation, and freight in connection with the foregoing remedy. The same obligations and conditions shall extend to replacement items furnished by Company here under. Company shall have the right of disposal of items replaced by it. The purchaser shall grant Company to determine any defect in the goods. If adjustment, repair, or replacement does not remedy the defect, Company and Purchaser shall negotiate in good faith an equitable adjustment in the contract price.

Company's responsibility does not extend to any item of the goods which have not been manufactured and sold by Company. Such an item shall be covered only by express warranty, if any, of the manufacture thereof. Company and its suppliers shall also have no responsibility if the goods have been improperly stored, handled, or installed or if the goods have not been operated or maintained according to their ratings or according to instructions in Company or supplier furnished manuals, or if unauthorized repairs or modifications have been made to the goods.

This warranty is expressly in lieu of all other warranties (except title), including but not limited to implied warranties of merchantability and fitness, and constitutes the only warranty of Company with respect to the goods.

The foregoing states Purchasers exclusive remedy against Company and its suppliers for any defect in the goods or for failure of the goods to be as warranted, whether Purchaser's remedy is based on contract, warranty, failure of such remedy to achieve its essential purpose, tort (including negligence), indemnity or any other legal theory, and whether arising out of warranties, representations, instructions, or defects from any cause.

Service calls and overtime are not covered under the ABB NEMA Motors warranty policy.

ABB Low Voltage NEMA Warranty type

A	GP100, GP100A	12 months in service or 18 months after shipment, whichever comes first
	SD10MS, SD100, XP100, XP 100 ID1, HP100, LP100, SD200, DP200 HPS	3 Years, after shipment
	SD100 IEE841, SD661, SD200 841	5 Years, after shipment
B	Remedy	ABB option to repair or replace
C	Purchaser's responsibility	Transportation damage claims, order management, removal, and freight
D	Exclusions	Improper storage, In and out costs, disassembly and installation, transportation damages
E	Shipment normal	FOB our dock, freight allowed

Reference notes

1. After the inspection, submit inspection report with all supporting documentation to ABBGDLWarranty@us.abb.com for authorization of repair or replacement. **Unapproved repairs will be denied.**
2. Removal, installation, freight, and service calls are NOT covered by warranty.
3. A standard EASA Warranty report must be filled out and an ABB purchase order # issued. If the motor is scrapped in the field, a clear picture of the nameplate cut in half, in addition to the invoice, must be submitted to ABBGDLWarranty@us.abb.com.
4. Replacement parts will be furnished at no charge from the factory, i.e., bearings fans, etc.
5. Replacement motors will be furnished at no charge from the factory. Should it be necessary for the service shop to replace a motor from their stock, a replacement motor will be furnished at no charge from the factory, shipped freight allowed.
6. Defective parts, i.e., bearings, are subject to return upon request to the factory for inspection and approval for reimbursement.

Date coding

ABB low voltage NEMA motors are date coded with the serial number on the nameplate.

Serial numbers beginning with “J” will have date codes using six digits in format YY MM DD.

Serial numbers beginning with “Q2” will have date codes using three digits. The first digit represents the month and is alphabetic beginning with A as January and ending with M as December (“I” is skipped in the sequence). The second and third digits are numeric and are the last two digits of the year.

IMPORTANT NOTICE

Mail or e-mail a proper warranty repair report and supporting evidence of failure to the warranty administrator. If ABB is to be billed for overtime, authorization must be obtained from the warranty administrator before overtime work is performed. Material and services are purchased for resale and are exempt from state and local sales and use tax.

1.4. Cancellation charges and change notices

Cancellation charges

Note: A minimum charge of \$100 will be assessed for any order cancellation for modified or custom motors.

Stock motors and spares

- No charges will be incurred if an order is cancelled prior to shipment.
- A stock motor is returnable (freight paid by purchaser) immediately after shipment if returned in "new" condition (original, undamaged packaging) for a minimum restocking charge of 20% of the motor net price.

Non-stock motors

- The following table is used to determine cancellation charges after a non-stock motor order is received and entered at the factory. Completion week will be determined by an ABB Customer Service Representative.
- A charge of 15% of the total net motor price will be assessed if an order is cancelled after it has been released for engineering and drafting whether the drawings have been completed and/or submitted for approval or not.

Change notice

All change notices applied to in-process orders logged into the ABB customer service department and requiring a product change will be subject to a \$100 net charge plus the applicable modification adder. Delivery dates will be adjusted according to the type of change/modification requested. This policy does not pertain to commercial changes such as "ship to" or "bill to" addresses.

Motor Cancellation Charges

Week	Contract A1	Contract A2	Contract B			
1	0%	0%	0%			
2	50%	25%				
3	95%	50%	25%			
4	100%	90%	50%			
5		100%	100%	75%		
6				90%		
7				100%	100%	100%
8						
9						
10						
>10						

2. Next Generation Low Voltage NEMA Motors

Technical details, options, motor selection, and pricing

SD200, SD200 841, DP200 HPS

- 2.1. Technical Details 12**
 - 2.1.1. MLFB Structure – Option Codes 12
 - 2.1.2. Technical Information 13
 - 2.1.2.1. Voltage and Connection 13
 - 2.1.2.2. Mounting..... 15
 - 2.1.2.3. Winding Protection.....17
 - 2.1.2.4. Terminal Boxes and Leads..... 21
 - 2.1.2.5. Bearings and Lubrication.....25
 - 2.1.2.6. Shafts and Seals.....28
 - 2.1.2.7. Frame30
 - 2.1.2.8. Rating Plates and Tagging 32
 - Ambient and Altitude 34
 - Mechanical Design & Accessories.....35
 - Paint and Packaging..... 37
 - 2.1.2.9. Documentation.....39
 - Tests 42
 - Calculations and Typical Control Settings 44
- 2.2. Motor Selection and Pricing..... 45**
 - 2.2.1. Severe Duty Low Voltage NEMA Motors45
 - 2.2.1.1. SD200..... 47
 - 2.2.1.2. SD200 841..... 55
 - 2.2.2. Definite Purpose Low Voltage NEMA Motors 60
 - 2.2.2.1. DP200 HPS..... 62
- 2.3. Option Selection and Pricing – Introduction..... 64**
 - Option Selection and Pricing.....66

2.1. Technical details

2.1.1. MLFB Structure – Option Codes

MLFB Structure	1	2	3	4	5	6	7	-	8	9	10	11	12	-	13	14	15	16	-Z
Motor Series	1	2	3					-						-					
Standard GP, SD Motors	1	L	E					-						-					
Definite Purpose Motors	1	P	C					-						-					
Main Series				4				-						-					
Next Generation NEMA Motors				6				-						-					
Motor Type/Enclosure/ Efficiency					5	6	7	-						-					
SD200	1	L	E	6	3	2	1	-						-					
SD200 841	1	L	E	6	3	2	2	-						-					
DP200 HPS	1	P	C	6	5	2	1	-						-					
Motor HP and Frame								-	8	9		11		-					
Ball Bearing Long Shaft 444-445T									4	B		*							
Ball Bearing Long Shaft 447-449T									4	C		*							
Ball Bearing Long Shaft L449T									4	D		*							
Ball Bearing Long Shaft 509-5011									5	A		*							
Ball Bearing Long Shaft L5011-5013									5	B		*							
Ball Bearing Short Shaft 444-445TS									4	F		*							
Ball Bearing Short Shaft 447-449TS									4	G		*							
Ball Bearing Short Shaft L449TS									4	H		*							
Ball Bearing Short Shaft 509-5011S									5	E		*							
Ball Bearing Short Shaft L5011-5013S									5	F		*							
Roller Bearing Long Shaft R444-R445T									4	S		*							
Roller Bearing Long Shaft R447-R449T									4	T		*							
Roller Bearing Long Shaft RL449T									4	U		*							
Roller Bearing Long Shaft R509-R5011									5	R		*							
Roller Bearing Long Shaft RL5011-R5013									5	S		*							
Number of Poles (Speed)								-			10			-					
2 Pole (3000/3600 RPM)											A			-					
4 Pole (1500/1800 RPM)											B			-					
6 Pole (1000/1200 RPM)											C			-					
8 Pole (750/900 RPM)											D			-					
Winding Design/Voltage/Frequency								-					12	-	13				
Mounting								-							-	14			
Winding Protection								-							-		15		
Terminal Box Position								-							-			16	
With Additional Options								-							-				-Z

2.1.2. Technical Information

2.1.2.1. Voltage and Connection

		440-L449 Frames	500 Frame
MLFB DIGITS 12 & 13	12 460V	12 Lead Delta / 6 Lead Delta Fig. 1.4 / Fig. 1.1	12 Lead Delta Fig. 1.4
	13 575V	6 Lead Delta Fig. 1.1	12 Lead Delta Fig. 1.4
	22 PWS 460V 60Hz	Part Winding Start Fig. 1.5	Part Winding Start Fig. 1.5
	23 PWS 575V 60HZ	Part Winding Start Fig. 1.3	Part Winding Start Fig. 1.5
	32 Y/D 460V 60Hz	12 Lead Wye-Start Delta-Run Fig. 1.6	12 Lead Wye-Start Delta-Run Fig. 1.6
	33 Y/D 575V 60HZ	6 Lead Wye-Start Delta-Run Fig. 1.3	6 Lead Wye-Start Delta-Run Fig. 1.3
	90 Special Winding (M6Y)	As Specified	

1. SD200 841 [Pricing](#)

Voltage

Low voltage NEMA motors can operate from 200-600V according to the winding selection. Windings up to 230V can only be applied to motors with 75HP or less.

Part-Winding-Start and Wye-Start/Delta-Run are special windings that help to limit the amount of inrush current at startup. Both options require a special motor starter to operate correctly.

Special voltage, **M6Y**, can be used for any voltage within the voltage range listed for each.

Low voltage NEMA motors are designed with the following tolerances in accordance with NEMA MG-1:

- Voltage tolerance: +/-10% of rated voltage
- Frequency tolerance: +/- 5% of rated frequency
- Voltage & frequency combined tolerance: +/-10% (sum of absolute values)

Winding connection

440 frames with 460V will have 12 lead connection as standard. When SD200 841 motors with 460 or 575V will have 6 lead connection with paired leads for flexibility in connection as seen in Figure 1.1.

500 frames will have 12 lead connection as seen in Figure 1.4.

See [Terminal Box and Leads section](#) for additional information on motor leads.

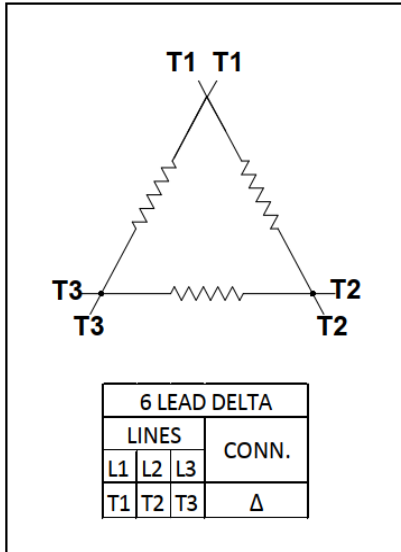

Figure 1.1

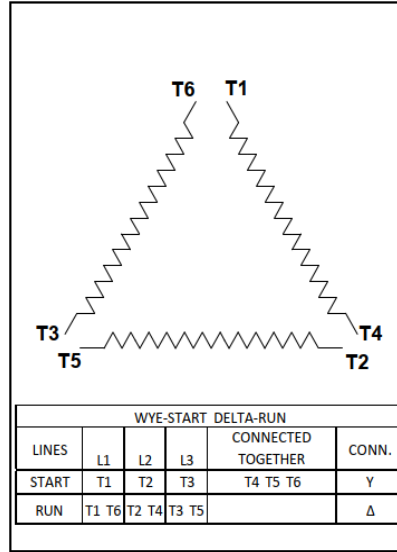

Figure 1.2

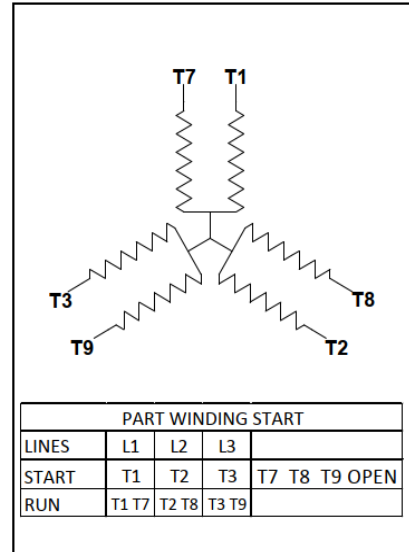

Figure 1.3

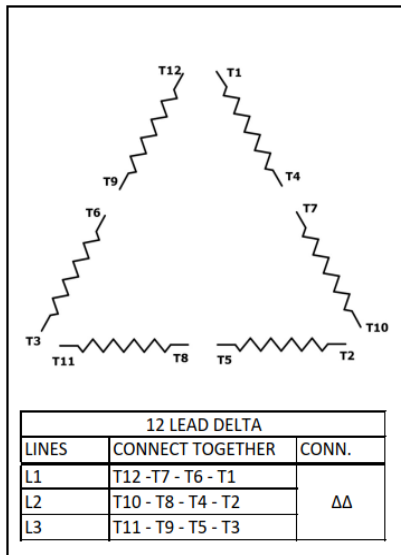

Figure 1.4

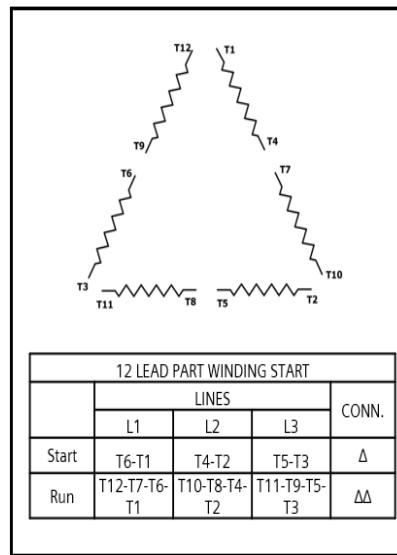

Figure 1.5

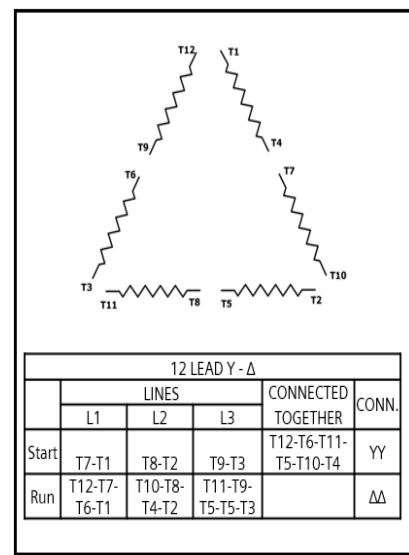
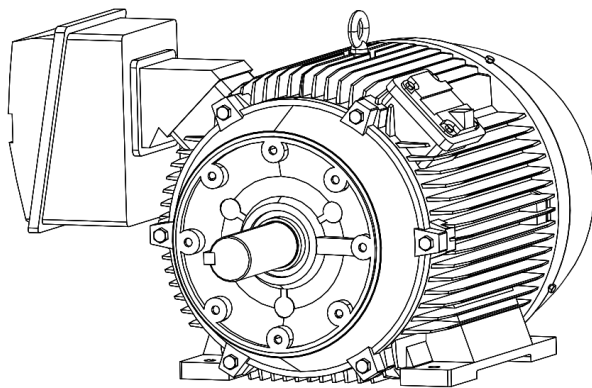

Figure 1.6

2.1.2.2. Mounting

	Codes	Description	1LE6	1PC6 HPS
MLFB DIGIT 14	A	Foot Mounted (Horizontal IMB3)	+	+
	C	Foot Mounted Vertical Shaft-down without Canopy (IMV5)	+	+
	D	Foot Mounted Vertical Shaft-up (IMV6)	+	+
	F	Footless D-Flange Horizontal (IMB5)	+	-
	G	Footless D-Flange Vertical Shaft-down w/o canopy (IMV1)	+	-
	H	Footless D-Flange Vertical Shaft-up (IMV3)	+	-
	J	Foot Mounted D-Flange Horizontal (IMB35 – F1/F2/F3)	+	+
	K	Footless C-Face Horizontal (IMB14)	+	-
	L	Footless C-Face Vertical Shaft-down w/o canopy (IMV19)	+	-
	M	Footless C-Face Vertical Shaft-up (IMV18)	+	-
	N	Foot Mounted C-Face Horizontal (IMB34 – F1/F2/F3)	+	+
	P	Foot Mounted C-Face Vertical Shaft-down w/o Canopy –(W6/W7/W12)	+	+
	Q	Foot Mounted C-Face Vertical Shaft-up – (W5/W8/W11)	+	+
	R	Foot Mounted D-Flange Vertical Shaft-down – (W6/W7/W12)	+	+
	S	Foot Mounted D-Flange Vertical Shaft-up – (W5/W8/W11)	+	+
	T	Foot Wall Mount Horizontal (MB6 – W2/W4)	+	+
	U	Foot Wall Mounted Horizontal (IMB7 – W1/W3)	+	+
	V	Foot Ceiling Mount Horizontal (IMB8 – C1/C2/C3)	+	+

+ Available • Standard – Not Available Pricing



C-Face Foot Mount

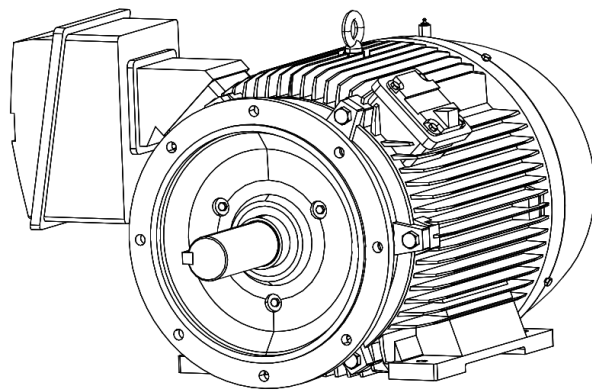

D-Flange Foot Mount

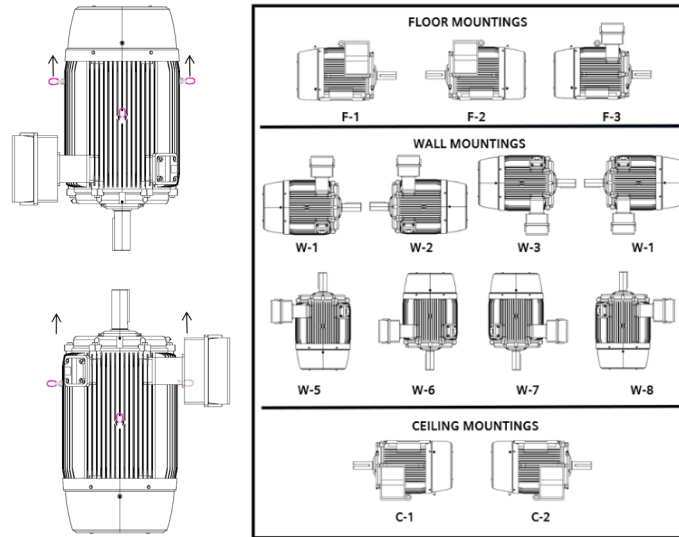

Foot mounting (no flange)

Foot mount motors without a flange will have universal mounting feet with mounting holes to cover a range of sizes. Motors may be configured to mount in vertical, horizontal, wall, or ceiling mount. The proper configuration may be critical to ensure the motor has proper drain locations, lifting provisions, and bearing configuration. Next Generation low voltage NEMA motors configured for vertical mounting will have three-point lifting provisions included.

Flange mounting

The drive end bearing housing can be replaced with flange mounting for direct coupling to the driven equipment. Flanges can be supplied with or without feet (coming soon) and as vertical or horizontal as required by the application. L449 frame must use the motor feet as support with flange mounting in either vertical or horizontal mounting positions.

Foot mounted motors can be offered with self-supporting D-flange on request. Contact the ABB Low Voltage NEMA Motor Quotation Team for a quotation.

C-Face

The NEMA C-face has threaded holes in the flange and the mounting hardware will be introduced from the driven equipment side. The C-face can be added to a stock motor as a modification where applicable.

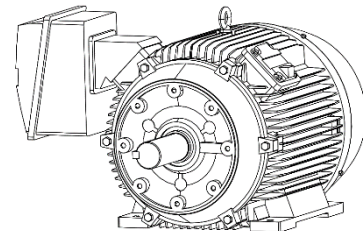

D-Flange

The NEMA D-flange will have through holes that are unthreaded. The D-Flange can be custom built with NEMA dimensions.

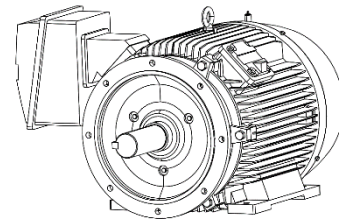

2.1.2.3. Winding Protection

	Codes	Description	1LE6	1PC6 HPS
MLFB DIGIT 15	A	No Protection	+	+
	B	PTC 3 Embedded (Trip), 1 Per Phase	+	+
	C	PTC 6 Embedded (Alarm & Trip), 2 Per Phase	+	+
	G	Thermostats Normally Closed, Temp Code T3C, 1 Per Phase	+	+
	J	Thermocouples Coil Head (Type J)	+	+
	K	Stator RTD's 100-Ohm Platinum with Aux Box-Terminal Strip 2 Per Phase	+	+
	L	Winding Protection - G + K	+	+
	P	PT1000, 2 Embedded Temperature Sensors	+	+
Short Codes	A46	Space Heaters 115V Single Phase, Max Temp 160°C	+	+
	A47	Space Heaters 230V Single Phase, Max Temp 160°C	+	+
	A48	Space Heaters 115/230V Single Phase, Max Temp 160°C	+	+
	A90	Control Module for PTC Thermistors	+	+
	C01	Insulation Vacuum Pressure Impregnation (VPI)	+	+
	C03	Spike Resistant Wire	+	+
	C04	Insulation Moisture/Powerhouse (Extra Dip & Bake)	+	+
	C07	Insulation Fungus Protection - No UL	+	+
	C08	Insulation Tropicalization (Extra Dip & Bake + Fungus Spray) – No UL	+	+

+ Available • Standard – Not Available Pricing

Winding insulation

The ABB low voltage NEMA motor stator is random wound and insulated with Class F insulation system which is compliant with NEMA MG-1 part 31 and is rated for 155 deg C. Spike resistant wire, **C03**, can be used to meet those more stringent specifications that require part 31 to be exceeded. The stator is protected from moisture with acrylic impregnation through a dip and bake process. The stator is designed to have a temp rise no greater than class B at nameplate horsepower.

Class H insulation is rated for 180 deg C and is used to better protect the stator when the temp rise may be higher due to ambient conditions or harsher VFD applications. Frame size 440 to 500 will have Class H insulation as a standard feature.

Moisture Powerhouse (extra dip and bake), **C04**, adds an extra layer of varnish to the winding for added protection against moisture. Vacuum Pressure Impregnation (VPI), **C01**, is an alternative to the standard dip and bake process. VPI uses a vacuum system to pull the varnish into the winding to reduce air bubbles in the varnish. Fungus Protection, **C07, C08**, is an anti-fungal spray that is applied to the windings after the dip and bake process to help reduce fungus from growing on the windings during storage prior to operation.

Space heaters

Space heaters help to reduce the humidity inside the motor during idle times of operation and storage. ABB uses flexible silicone rubber space heaters that have been proven to provide long life which either meets or exceeds the overall life of ABB NEMA motors. Space heaters will have wattage corresponding to the voltage and motor size as seen in Table 3.1 and will have leads to the main box as standard or an aux box as an option with leads marked per Figure 3.1.

ABB offers low temp space heaters rated for a max surface temperature of 160 deg C for use in safe area or Division 2 areas. The heaters can be configured for operation on 115V supply, **A46**, 230V supply, **A47**, or 115/230V, **A48**.

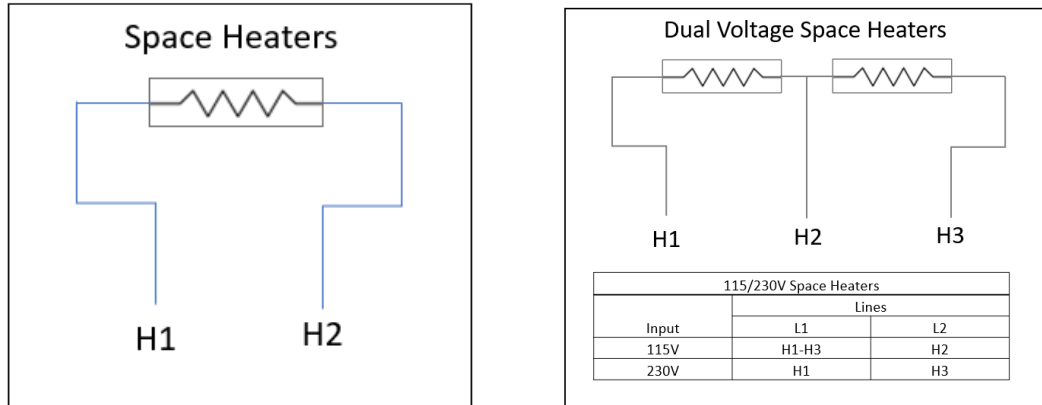

Figure 3.1.

Order Code	Frame	Voltage	Qty	Size (inches)	Watts
A46	400-S449	115	2	2.5 x 20	100
A47	400-S449	230	2	2.5 x 20	100
A48	400-S449	115/230	2	2.5 x 20	100
A46	FS500	115	2	2.5 x 20	100
A47	FS500	230	2	2.5 x 20	100
A48	FS500	115/230	2	2.5 x 20	100

Table 3.1.

Winding temperature protection

Thermostats, **MLFB Position 15 “G”**, are supplied as normally closed. When the temperature of the motor reaches the rated temperature of the device, the switch will open and cause a trip condition. Thermostats will have leads to the main box as standard or an aux box as an option with leads marked per Figure 3.2.

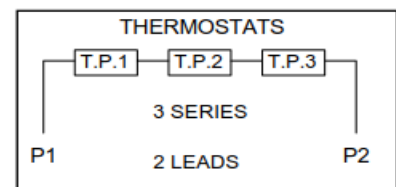

Figure 3.2

PTC (positive temperature coefficient) thermistors, **MLFB Position 15 “B or C”**, are resistive devices that increase in resistance as the temperature increases. They are set to jump to a very high resistance at a rated temperature. Options are available to have one per phase for trip only, “B”, or two per phase for alarm and trip, “C”. PTC thermistors will have leads to the main box as standard or an aux box as an option with leads marked per Figure 3.3 and Figure 3.4.

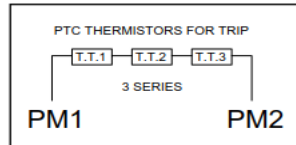

Figure 3.3

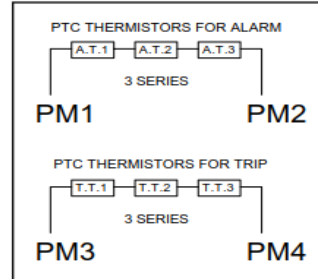

Figure 3.4

Stator RTDs, **MLFB Position 15 “K”**, are PT100 resistive thermal devices that can be used to monitor the temperature of the motor based on the measured resistance of the device. The resistance range will be 100 ohms at 0 degrees C and increase at a rate of .385 ohms per degree C. RTDs are supplied with two sets per phase (one set active and one set as spares) embedded in the DE end turn of the winding. This option also includes an aux box with a terminal strip with terminals marked per Figure 3.5.

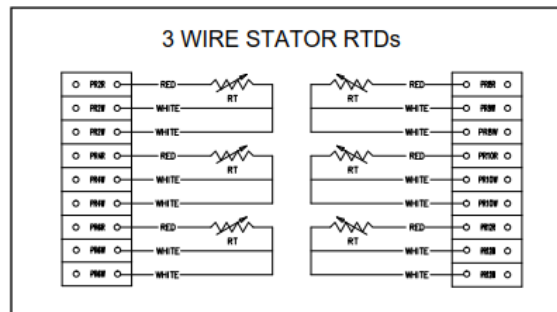

Figure 3.5

PT1000 sensors, **MLFB Position 15 “P”**, function like the PT100 stator RTDs. The resistance range for the PT1000 sensors is 1000 ohms at 0 degrees C and increases at a rate of 3.85 ohms per degree C. This option comes with two independent sensors (one active and one spare) embedded in the DE end turn of the winding. PT1000 sensors will have leads to the main box as standard or an aux box as an option with leads marked per Figure 3.6.

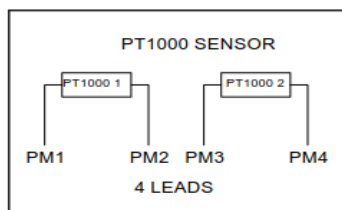

Figure 3.6

2.1.2.4. Terminal Boxes and Leads

	Codes	Description	1LE6	1PC6 HPS
MLFB DIGIT 16	1	LHS Mount - View from DE - Drive End	+	+
	2	RHS Mount - View from DE - Drive End Side	+	+
	3	Top Mounted Terminal Box from LHS - Drive End Side	+	+
	4	LHS Mount - View from DE - Non-Drive End Side	+	+
	5	RHS Mount - View from DE - Non-Drive End Side	+	+
	6	Top Mounted Terminal Box from RHS - Non-Drive End Side	+	+
Short Codes	J84	Conduit Box Orientation 90° CCW (Entry from DE)	+	+
	J85	Conduit Box Orientation 180° CCW (Entry from Top)	+	+
	J86	Conduit Box Orientation 270° CCW (Entry from NDE)	+	+
	K80	BURNDY HYDENT YA Type Terminals	+	+
	K81	Special Cable Leads, 60" Long	+	+
	K82	Special Cable Leads, 120" Long	+	+
	K83	Terminal Block - 3 Lead Only	+	+
	K89	Sealed Leads	+	+
	*Rx0	Cast Iron Aux Box for - Position 1 (F1 DE)	+	+
	*Rx1	Cast Iron Aux Box for - Position 2 (F2 DE)	+	+
	*Rx2	Cast Iron Aux Box for - Position 4 (F1 NDE)	+	+
	*Rx3	Cast Iron Aux Box for - Position 5 (F2 NDE)	+	+
	*Rx4	Condulet Box for - Position 1 (F1 DE)	+	+
	*Rx5	Condulet Box for - Position 2 (F2 DE)	+	+
	*Rx6	Condulet Box for - Position 4 (F1 NDE)	+	+
	*Rx7	Condulet Box for - Position 5 (F2 NDE)	+	+
	T00	Main Terminal Box – at 45° Angle	+	+
	T03	Main Terminal Box – Oversized Steel (Centered Cable Entry)	+	–
	T04	Steel Terminal Box - Oversized 20"X20"X16" with blank entry	+	+
	T05	Steel Terminal Box - Oversized 28.5"X24.4"X20" with blank entry	+	+
	T06	Steel Terminal Box - Oversized 18.5"X22"X7.5" with blank entry	+	–
	T10	Centered Terminal Box	+	–
	T11	Centered Retrofit Terminal Box	+	–
T50	Dual Entry Hole Terminal Box	+	+	
Y96	Non-Standard NPT entry	+	+	

+ Available • Standard – Not Available Pricing

DE = Drive End, NDE = Non-Drive End, LHS = Left Hand Side, RHS = Right Hand Side

Terminal leads

All low voltage NEMA motors come standard with flying leads (no terminal block) terminated using ring terminals. The leads are Class H insulated and identified with permanent marking. Terminal block, **K83**, is available as an option. **Note:** Option **K83** will prevent modifications from F1 to F2 due to reduced cable length.

As standard terminal leads will be of sufficient length to execute the termination to the power leads inside the terminal box or convert to one of the DE terminal box positions.

Special cable length can be supplied with leads extended to 60", **K81**, or 120", **K82**, outside the motor frame.

Main terminal boxes

The main conduit box is diagonally split with a single entrance hole (see drawing section for standard entry hole size) with internal grounding lug provided as standard. The standard terminal box will be cast iron and have a volume that is greater than required by NEMA/NEC. Terminal box will be supplied with a gasket between conduit box and frame and between cover and base.

Dual entry terminal box is available as an option, **T50**, and will have NPT size per [drawings and dimensions section](#). Non-standard NPT, Y96, must be defined in the order and meet the criteria defined in Table 4.1. Options **T50** and **Y96** may be used in combination to achieve a non-standard dual entry.

Frame	Max single NPT	Max Dual NPT
444-447	4.5"	2 x 2.5"
449-L440	5"	2 x 4"
500	5"	2 x 4"

Table 4.1

ABB Next Generation low voltage NEMA motors have a variety of terminal box mounting options. There are 4 locations for L449-FS500 and 2 locations (DE only) for FS444-449 on the frame where the main box or auxiliary boxes can be mounted. The motors will come as standard with the box on the DE at a 90 deg angle and can be modified to 45 deg, **T00**, with a simple conversion. See figure 4.1 for illustrations of terminal box mounting possibilities.

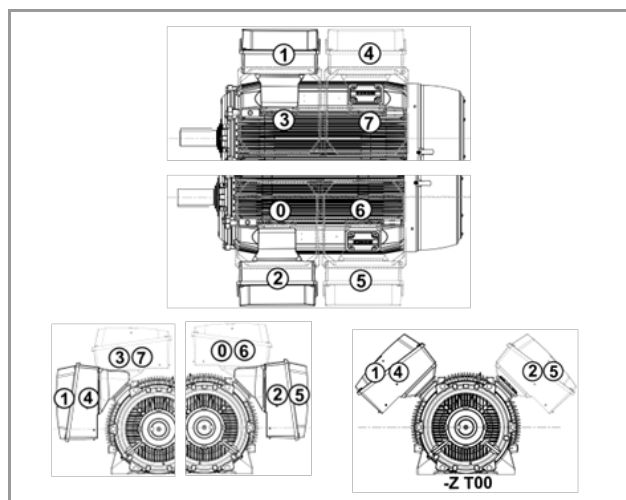

Figure 4.1

444-449 frame terminal box can be offered with options for centered box for retrofit applications.

Centering neck, **T10**, relocates the standard box to the center of the motor Figure 4-2. Centering neck with oversized box, **T11**, relocates the box to the center of the motor with an oversized cast iron box that places the entry hole closer to the vertical position of the SD100 Figure 4-3.

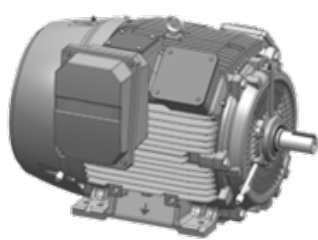

Figure 4.2

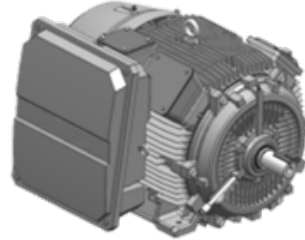

Figure 4.3

Oversized with the entry hole location centered between the foot holes for retrofit applications or where the centered box is desired. The oversized box is available as Steel, **T03**.

Oversized steel boxes, **T04, T05, T06**, are available in three sizes with the blank entry. See [drawings and dimensions section](#) for additional details.

The main terminal box position is defined by the 16th position of the MLFB as illustrated in Figure 4.1. The connection entry will be facing the motor feet as standard when supplied on the side of the motor or facing the F2 side when top mounted. The terminal box may be rotated in 90-degree increments in the field or by ordering with options **J84, J85, J86**.

Auxiliary terminal boxes

Auxiliary terminal boxes are available for accessories included in the motor selection. The auxiliary box can be attached to the motor frame or to the side of the main terminal box. Aux box, **Rx0, Rx1, Rx2, Rx3** will be a cast iron auxiliary box. Condulet, **Rx4, Rx5, Rx6, Rx7** is an aluminum electrical condulet with a steel cover. The auxiliary box option should be selected according to the accessory that it will be paired with in the positions illustrated in Figure 4.7

Space Heaters and other thermal protection will route to main box unless aux box is selected.

If aux box/Condulet is configured in the same position as main box, the aux will be attached to the main, Figure 4.4.

Positions 4 and 5 will be attached to motor frame at 90 degrees with pipe nipple for frames 444-449, Figure 4.6, and attached to cover plate for frames L449-500, Figure 4.5.

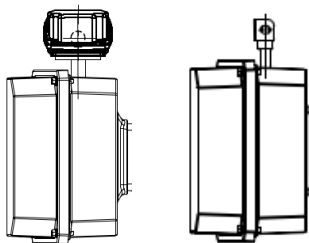

Figure 4.4

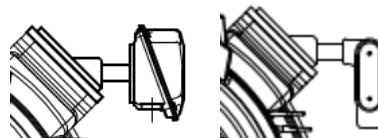

Figure 4.5

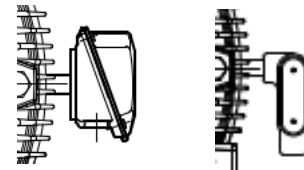

Figure 4.6

	Thermal Protection ¹	Space Heaters	All Accessories in the same box
Cast Iron Aux Box - Position 1 (F1 DE)	R00 ²	R10	R20 ²
Cast Iron Aux Box - Position 2 (F2 DE)	R01 ²	R11	R21 ²
Cast Iron Aux Box - Position 4 (F1 NDE)	R02 ²	R12	R22 ²
Cast Iron Aux Box - Position 5 (F2 NDE)	R03 ²	R13	R23 ²
Condulet Box - Position 1 (F1 DE)	R04 ³	R14	R24
Condulet Box - Position 2 (F2 DE)	R05 ³	R15	R25
Condulet Box - Position 4 (F1 NDE)	R06 ³	R16	R26
Condulet Box - Position 5 (F2 NDE)	R07 ³	R17	R27

2. No charge when Stator RTDs are included in MLFB Pos 15 as (K) or (L)

3. Condulet boxes cannot be used with stator RTDs

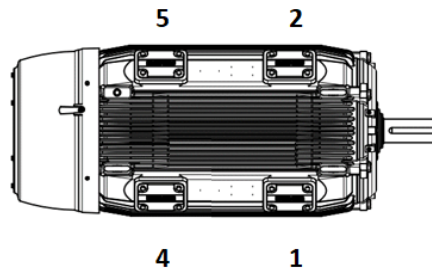

Figure 4.7

Stator RTDs will come with an aux box with a terminal strip included as standard. As standard the aux box will be on the same side as the main box. This box may be relocated using one of the cast iron thermal protection options at no additional charge. Bearing RTDs, **A51**, does not require an auxiliary terminal box, as it comes standard with terminal heads on each bearing housing.

2.1.2.5. Bearings and Lubrication

	Codes	Description	1LE6	1PC6 HPS
Short Codes	A50	Install BRG RTD's-100 Ohm Platinum- Both Ends & Terminal Heads/Block	-	+
	A51	Bearing RTD's-100 Ohm Platinum- Both Ends & Terminal Heads/Block	+	-
	L49	Automatic Grease Relief Fitting	+	+
	L50	Bearing Insulation for DE	+	+
	L51	Bearing Insulation for NDE	+	+
	L54	Provisions for Oil Mist	+	+
	L55	Oil Mist Ready	+	+
	L57	MOBIL 28 - High or Low Ambient – Special Grease	+	+
	L58	MOBILITH SHC 100 – Special Grease	+	+
	L61	Insulated Bearing – INSOCOAT (Both Ends)	+	+
	L62	Insulated bearing - INSOCOAT (on DE)	+	+
	L64	Insulated Bearing – INSOCOAT (NDE Only)	+	+
	L68	Sealed Ball Bearings (Both Ends)	+	-
	L69	Hybrid (Ceramic Ball) Bearings – Both Ends	+	+
	L70	Hybrid (Ceramic Ball) Bearings – NDE	+	+
	L71	Hybrid (Ceramic Ball) Bearings – DE	+	+

+ Available • Standard - Not Available Pricing

Lubrication

Standard lubrication for all low voltage NEMA motors is EXXONMOBIL POLYREX EM (Polyurea-based grease).

MOBIL 28 Grease, **L57**, has a wide temperature range with a clay base thickener ideal for low ambient conditions down to -50C. This option is supplied as standard for low ambient option codes **B27**, **B28**, and **B29**.

MOBILITH SCH 100, **L58**, is a Lithium base alternative to our standard POLYREX EM.

Grease inlet (Alemite fitting) is standard on all SD, and DP NEMA products. SD200 841 motors include Alemite and automatic grease relief fittings as standard, **L49** option is available for other severe duty motors.

Oil mist ready, **L55**, and Provisions for oil mist, **L54**, are possible on Severe Duty motors horizontal foot mount only. Bearings must be single shield ball bearings with shields to inboard side. Motor leads are sealed to prevent mist from entering conduit box and lead material used is resistant to oil mist.

Oil mist ready will only have enough grease in the bearings to complete the routine test.

Provisions for oil mist will include the required machining on the bearings housings to be switched to oil mist in the future. The motor will be supplied as a fully greased motor with standard re-greasing provisions. Hardware and instructions will be included with the motor to switch from grease lubrication to oil mist.

Sealed Bearings, **L68**, are greased for life bearings and will not require re-lubrication. When sealed bearings are supplied on SD200 841 motors, the motors will be marked as “IEEE Std 841-2021 features”. **Note:** Not possible for roller bearing or with other bearing or greasing options.

Bearings

Standard re-greaseable bearings for ABB low voltage NEMA motors have an L10 bearing life of 100,000 hours for direct coupled applications and 50,000 hours for belted applications when properly sized for the application and with proper maintenance. See **Technical Tables section** for standard bearings sizes.

Bearing temperature protection

Bearing RTDs, **A51**, included temperature monitoring on both the drive end and non-drive end bearing. The bearing housing is drilled and tapped for the temperature probe to rest on the outer race of the bearing with the leads in a terminal head on each end (Fig. 5.1). This allows for independent temperature monitoring for each bearing.

DP200 HPS motors will include provisions for bearing RTDs as standard. The installation of the RTDs, **A50**, can be added as a modification on this product.

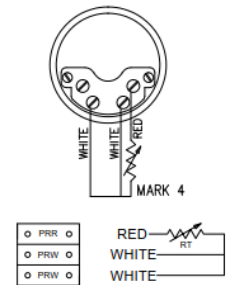

Figure 5.1

Overhung load/belted considerations

ABB recommends a roller bearing on the DE for overhung load applications. Roller bearing on DE is standard on R440 and R500 frame.

Belting details can be evaluated, **F09**, by ABB Engineering on request. The belting form can be requested through the Low Voltage NEMA Motor Quotation Team. Minimum criteria for belting evaluation are listed below and cannot be properly evaluated without this data. Refer to Figure 5.2 for dimension illustration.

- Operating application horsepower
- Operating RPM
- Frame size of selected motor
- D_r = Motor sheave diameter (see Table 5.1)
- D_n = Driven sheave diameter
- Number of belts
- Type of belts (e.g., 3V, 5V, 8V, A, B, C, etc.)
- C = Distance between sheaves (center to center)
- L = Center of motor sheave to end of shaft
- Orientation of motor
- W_s = Face width of motor sheave

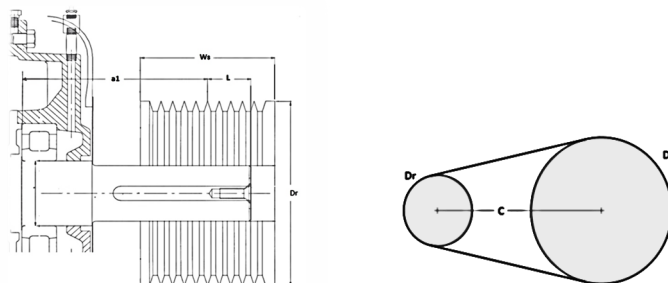

Figure 5.2

Recommended Sheave Diameters for V-belts

Frame	HP Synchronous RPM			Standard V Minimum Diameter (in.)	Narrow V Minimum Diameter (in.)
	1800	1200	900		
444T	–	–	75	10.5	9.5
444T	–	100	–	11.0	10.0
444T	125	–	–	11.0	9.5
445T	–	–	100	12.5	12.0
445T	–	125	–	12.5	12.0
445T	150	–	–	13.2	10.5
447T	200	–	–	15.8	13.2
449T	250	–	–	18.4	13.0
449T	300	–	–	24.8	15.4
L449L	350	–	–	–	15.8
L449L	400	–	–	–	18.0

Table 5.1

Notes:

- Narrow V Example: 3V, 5V, 8V.
- Standard V Example: A, B, C, D section
- Do not exceed belt service factor of 1.6.
- Maximum speed reduction of 5:1
- Shaft center distance approximately equal to diameter of largest sheave
- The motor sheave should be located as close as possible to the bearing (1/2" from shaft shoulder)
- The center of the belt system should never extend beyond the end of the motor shaft

VFD application considerations for bearings

Shaft currents caused by VFD supply can cause damage to bearings that can result in bearing failure. The shaft currents tend to increase as the frame size increases. ABB recommends the use of an insulated bearing on the NDE of frames 400 and larger to reduce the risk of the shaft current passing through the bearing.

Bearing Insulation, **L50** and **L51**, is a proprietary system that will use standard ball or roller bearings with an insulating composite compound between the shaft and bearing. The compound has a working temperature range of -50C up to 150C and will be permanently fixed to the shaft. **Note: Standard 6322 bearing will be reduced to 6222 with options L50 and/or L51.**

Hybrid ceramic bearings, **L69**, **L70** and **L71**, are a direct replacement for the standard bearing size and are fully regreasable. They utilize ceramic balls to eliminate the currents from passing through the bearings. **Note: Not available for roller bearing.**

INSOCOAT Bearings, **L61**, **L62**, **L64**, are a direct replacement for the standard bearing size and are fully regreasable. An insulated coating on the outer race of the bearing is used to reduce the risk of the currents passing through the bearing.

See [Shafts and Seals](#) for additional options to reduce bearing damage due to shaft currents.

2.1.2.6. Shafts and Seals

	Codes	Description	1LE6	1PC6 HPS
Short Codes	K41	Keyless Shaft	+	+
	K42	Retrofit S449 Shaft Extension	+	-
	L29	Shaft Grounding Brush	+	+
	L76	Shaft Slinger & O Ring	+	-
	L79	INPRO/SEAL Drive End	+	+
	L80	INPRO/SEAL Non-Drive End	+	+
	L81	INPRO/SEAL Both Ends	+	+
	L86	INPRO/SEAL MGS Shaft Grounding - Drive End	+	+
	M52	NEMA Std Long Shaft - Non-Drive End	+	-
	M53	NEMA Std Short Shaft - Non-Drive End	+	-
	M57	(C4140) Carbon Steel Shaft	+	+
	Y50	Special Shaft Dimensions on Drive End	+	+
	Y51	Special Shaft Dimensions on Non-Drive End	+	+

+ Available • Standard - Not Available Pricing

Shafts

The standard shaft material will be C1045 or C4140 as noted in Table 6.1. C4140 shaft material is available as a custom option, **M57**, on frames with C-1045 as standard. Low voltage NEMA motors are designed with the shaft dimensions and tolerances to meet the standards of NEMA MG-1 single shaft extension. Any exceptions will be noted on the motor drawings. DE shaft will have drill and tap shaft as standard as provisions for shaft locking device for shipment, see [drawings and dimensions section](#) for details.

Frame	Standard Shaft Material
444-L449	C-1045
500 (2 Pole)	C-4140
500 (4 & 6 Pole)	C-1045

Table 6.1

Motors in frame 444-449 can be custom built with a double shaft extension with NDE shaft according to NEMA MG-1. This can be offered as either long shaft, **M52**, or short shaft, **M53**. See [drawings and dimensions section](#) for reference.

Keyless DE shaft extension, **K41**, is available as a custom feature. All other shaft dimensions will remain in accordance with NEMA MG-1.

Motors can be custom built with a special shaft extension on DE, **Y50**, or NDE, **Y51**. These options can be used for special dimensions of N-W, U, and keyway only and will be limited to max dimensions noted in Table 6.2. If **Y50** and **Y51** are used together the combined N-W may not exceed value noted in Table 6.2.

Any special features to shaft (special drill and tap) must be quoted by the ABB NEMA Motor Quotation Team.

Frame	Max U dim	Max N-W dim	Max FU dim	Max FN-FW dim	Max N-W + FN-FW
444-L449	3.875"	15"	2.875"	15"	15"
500 (2 Pole)	3"	9"	3"	3"	9"
500 (4 & 6 Pole)	4.25"	CF	3"	CF	CF

Table 6.2 CF = Consult Factory

Seals

Shaft seals are used to protect the bearings from liquid and dust contaminants that lead to premature bearing failure. NEMA motor are equipped with v-ring shaft seals as standard on all severe duty motors unless otherwise noted. The v-ring shaft seal provides protection to meet IP55.

Labyrinth seals (Inpro Seals, **L79**, **L80**, and **L81**), are shaft rotating seals that provide extra ingress protection from water and dust while the motor is in operation. Motors that are noted to meet IEEE 841 or when IEEE 841 features, **K10**, will include labyrinth seals on both ends. The 500 frame motors will have a labyrinth seal on the DE as standard.

Shaft slinger and O-ring, **L76**, is used in shaft up applications to help reduce liquid from running down the shaft and settling in the seal area.

VFD application considerations for shaft grounding

Shaft grounding can reduce the risk of shaft currents from passing through the bearings.

This allows the current generated in the shaft to flow harmlessly to the frame and ultimately to ground bypassing the bearings in the process. Shaft grounding options are considered sparking devices and cannot be used in hazardous areas. When selected for SD products, the Division 2 information will be removed from the nameplate.

SGS™ Motor Grounding Brush & Ring Systems, **L29**, mount on the fan housing with a carbon brush that contacts the motor shaft. The carbon brush is rated at 100,000 hours before being changed. **Note: Not possible in combination with G05, G06, H04, M08, or Y51.**

Bearing Isolator + grounding brush, (MGS INPRO Seal, **L86**), uses the labyrinth sealing protection of an INPRO Seal combined with shaft grounding brushes that rest on the shaft behind the sealing mechanism. The brushes reduce the shaft currents from passing through the bearings while the seal reduces contamination build up on the grounding brushes and in the bearing. **Note: This option may reduce the usable shaft length.**

2.1.2.7. Frame

	Codes	Description	1LE6	1PC6 HPS
Short Codes	K33	Drip Cover	+	+
	K38	Provisions for Dowel Holes	+	•
	K70	Rotation Arrow Bi-directional	+	+
	K71	Rotation Arrow Clockwise (from NDE)	+	+
	K72	Rotation Arrow Counterclockwise (from NDE)	+	+
	L22	Stainless Steel Hardware (Includes T Drain SS, and eyebolt)	+	+
	L27	Ground Bolts - Qty 2	+	+
	L45	SS T-Slot Breather Drain	+	+
	L46	CROUSE HINDS UL Approved Breather/Drain	+	+
	L91	IP56 Ingress Protection	+	–
	M10	Bronze Fan	+	–
	M39	Vertical Jacking Provisions	+	+

+ Available • Standard – Not Available Pricing

Feet

Motors with cast iron frame will have cast feet as standard.

Provisions for dowel holes, **K38**, provides a hole drilled at an angle in each of the motor feet. The holes will be used as a guide for drilling the mounting plate for the addition of the dowel once the motor is aligned to the driven equipment. Dowels can be used to pinpoint the alignment of the motor to the driven equipment when the motor is taken out for service. Provisions for dowels is a standard feature on the SD200 500 frame motors.

Motors will be delivered as standard with dual/tri drilled mounting holes in the feet for increased flexibility in mounting.

Provisions for vertical jacking, **M39**, provides threads in the non-mounting holes on the feet in order that a bolt may be added for leveling of the motor during installation. Jacking provisions are required on motors that exceed 500 lbs to meet API610 requirements for horizontal pump applications.

Lifting

Horizontal cast iron motors up to L449 will be supplied with an eye bolt located in the center line of the center of gravity on the motor frame. 500 frame motors are provided with two lifting eye bolts located at opposite corners of the motor frame. They will also include alternate locations on the motor where the eye bolts can be relocated. Foot mounted motors configured for Vertical orientation, as defined in position 14 of the MLFB, will include three swivel lifting hoist ring to provide safer movement of the motor.

Fan and fan cover

The standard bidirectional cooling fan is non-sparking polypropylene design, unless otherwise noted. Directional fans will have polypropylene blades with metallic mounting. Bronze fans, **M10**, are non-sparking and may be used on bi-directional motors.

Bi-directional arrow, **K70**, or Unidirectional rotation arrows, **K71**, **K72**, can be added to the fan housing when a single direction of rotation is desired. Direction of rotation will be as viewed from the NDE.

Note: **Unidirectional arrows do not change the fan to unidirectional fan.**

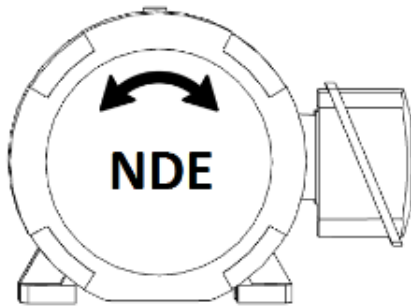

Metallic fan cover will be included as standard on all SD motors.

Drip cover, **K33**, can be added to the fan cover of motors used in vertical shaft down applications in order to protect the motor from water or liquids from falling directly into the fan housing. See [Drawings and Dimensions section](#) for drip cover dimensions.

Hardware

Standard hardware is grade 5 zinc plated corrosion resistant hardware. Stainless steel hardware, **L22**, includes all external nuts and bolts as well as the T-Drain and eyebolt(s). Stainless steel hardware is included with options for low ambient temperature, **B29**. Stainless steel T-drain, **L45**, will include only the drain as stainless steel.

All low voltage NEMA motors will include tapped holes on each side of the frame near the feet for frame grounding. Bronze ground bolts, **L27**, can be added (one on each side) for additional provisions.

Drain plugs require the user to unscrew the plug to allow the moisture to escape during times of idle use. T-slot drains allow for moisture to drain from the motor freely without user intervention. Crouse Hinds drains, **L46**, are UL approved breather/ drains that can be added.

Ingress Protection

The ingress protection (IP) rating is the protection grade against water and dust. The IP rating on the nameplate applies to completed motor, including shaft seals, bearing housing fits, and terminal box. The first number designation in the IP rating, IP_*, relates to the protection against water. The second number designation in the IP rating, IP*__, relates to the protection against dust. SD200 motors will have IP55 rating. Additional features can be added to increase to IP56, **L91**. SD200 841 will have IP56 as a standard feature.

2.1.2.8. Rating Plates and Tagging

	Codes	Description	1LE6	1PC6 HPS
Short Codes	M21	Additional Nameplate (Without Logos)	+	+
	M25	Class II, Divisions 2, Aux Tag	+	+
	Y80	Derate-Altitude-Ambient (Nameplate Change)	+	+
	Y82	Auxiliary n/p Max. 40 Characters (Aux Tag)	+	+

+ Available • Standard – Not Available Pricing

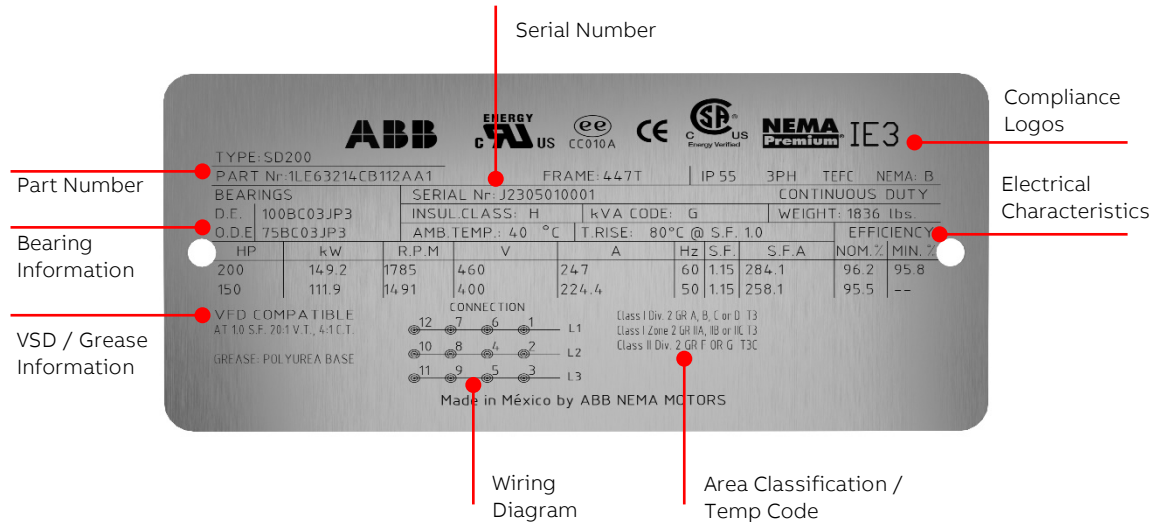

Motor main nameplate

SD200 main nameplate will be provided with data as seen in Figure 8.1.

Motor main nameplate may be modified, **Y80**, for de-rate, re-rate, deviated altitude, deviated ambient, or information added to the main nameplate. Information must be consistent with guidelines listed in catalog or applicable standards for de-rate or re-rate and within the limitations set in the ambient and altitude section. Consult the ABB NEMA Motor Quotation Team for special conditions.

Note: ABB reserves the right to reject/ hold an order based on inconsistent information or the lack of information provided for option Y80. When additional information is requested on the nameplate, it may result in standard information being displaced or removed due to space restrictions.

Auxiliary plate

Additional information can be provided on an auxiliary plate, **Y82**, for free text provided by customer in PO. This is often used for customer tagging or customer instructions. The tag has a character limit of 40 which includes spaces and special characters. **Note: ABB will not be held accountable for free text provided by customer that is provided in the PO that proves to be inconsistent with the motor design (unless specified in a custom quotation by the ABB NEMA Motor Quotation Team).**

Hazardous area classification

Next Generation Severe Duty low voltage NEMA motors up to L449 frame will include Class I, Division 2 and Class II, Division 2 information standard on the main nameplate. 500 frame motors will include Class I, Division 2 information on the main plate and may have Class II, Division 2 added with option **M25**. **Note: M25 will also include additional features required for compliance. Associated Zone 2 data will also be included.**

Division 2 information will not be included when one of the following options are selected: **H04, G05, G06, L29, L86** or any other feature that may be deemed as a sparking device.

Ambient and Altitude

	Codes	Description	1LE6	1PC6 HPS
Short Codes	B27	+40°C to -30°C Ambient Temp	+	+
	B28	+40°C to -40°C Ambient Temp	+	+
	B29	+40°C to -50°C Ambient Temp	+	+

+ Available • Standard – Not Available Pricing

Standard ambient and altitude

ABB Severe Duty NEMA motors are suitable for operation at an altitude up to 3300 feet (1000 meters) above sea level with an ambient temperature range of -25°C to 40°C with 1.15 service factor as standard.

Increased ambient or altitude

Altitude can be adjusted up to 9900 feet or Ambient can be adjusted up to 55°C with a reduction in service factor to 1.0 using **Y80** option code.

Motors with Class H insulation may be re-nameplated for up to 50°C ambient with 1.15SF and Class F temp rise.

Altitude may also be increased with reduction in ambient per Table 9.1.

For altitude above 9900 feet or ambient above 55°C please contact the ABB NEMA Motor Quotation Team.

Maximum Altitude	Maximum Ambient
3300 ft (1000m)	40°C (104°F)
6600 ft (2000m)	30°C (56°F)
9900 ft (3000m)	20°C (68°F)

Table 9.1

Ambient temperatures below -25°C can cause standard grease to become ineffective and some standard metals to become brittle leading to motor failure or damage. Features for low ambient conditions can be added as custom build, **B27** for down to -30°C, **B28** for down to -40°C, **B29** for down to -50°C, include special grease, external hardware, shaft material, lead material, and seals for suitability for the low temperatures.

Mechanical Design & Accessories

	Codes	Description	1LE6	1PC6 HPS
Short Codes	A67	Provision for Vibration Sensors	+	•
	A68	Metrix Sensors Installed on DE and NDE, top of the end shield	+	+
	G05	DYNAPAR Encoder HS35R 1024 PPR	+	+
	G06	C-Face Mounted SLIM Tach Encoder	+	+
	K10	IEEE 841 Features	+	+
	M08	Separately Driven Fan	+	+
	M69	Precision Balance	+	-
	M70	Extra Precision Balance	+	•

+ Available • Standard - Not Available [Pricing](#)

Vibration monitoring

Provisions for vibration sensors, **A67**, will provide 1/4"–28 UNF drilled and tapped holes on each bearing housing when selected with no additional instruction. This option can also be adapted to the required drill and tap required for a customer specified vibration sensor with quote from LOW VOLTAGE MOTOR quotation team. DP200 HPS motors in 500 frame will have provisions for vibration sensors as a standard feature.

Metrix vibration sensors, **A68**, includes the provisions and install of one ST5484E (4-20 MA) transmitter on each end of the motor.

Encoders

DYNAPAR HS35R, **G05**, is a hollow shaft rotary pulse 1024 PPR encoder with single output. It is mounted on an NDE shaft extension that extends beyond the fan housing. It is held in place with an arm that is attached to the fan housing. DYNAPAR SLIM Tach ST85, **G06**, is a c-face mounted 1024 PPR encoder with single output. **Note: Encoder options will remove hazardous area information from nameplate.**

Additional cooling for VFD applications

External Force cooling, **M08**, can be added to severe duty motors for increased turndown on VFD applications. The blower motor voltage & applicable order codes like a special paint, rotation arrow, box position, etc. will follow the drive motor. The blower kit will include a secondary connection box located on the fan housing. See [Dimensions Section](#) for added length.

Standards

IEEE 841 Features, **K10**, adds the applicable features of IEEE 841 to the motor. This option is only available for frame size 500 motors. Motors over 500 HP fall outside the scope of IEEE 841 and will be nameplated with "IEEE 841 Features."

Balance

SD200 motors up to L449 frame are dynamically balanced to commercial limits measure in accordance with NEMA MG1-12.06. Precision and Extra Precision balance, **M69, M70**, provides more stringent balancing guidelines. FS500 motors will have extra precision balance as standard. See [Technical Tables](#) for balance values.

Paint and Packaging

	Codes	Description	1LE6	1PC6 HPS
Short Codes	B07	Stackable Packing Crate	+	-
	B09	Export Packaging Sea freight – ABB Standard	+	+
	B11	Export Packaging Sea freight – ABB Standard + sensors	+	+
	N01	2 Part Epoxy (Industrial-Coastal Low Salt)	+	+
	N02	3 Part Epoxy (Industrial-Coastal Moderate Salt)	+	+
	N03	Primer Only	+	+
	N05	3 Part Epoxy (Coastal-Offshore High Salt)	+	+
	N06	2 Part Epoxy C4 (Industrial-Coastal Moderate Salt)	+	+
	N07	2 Part Epoxy C5I/C5M (Coastal-Offshore High Salt)	+	+
	Y60	Special color (Provide RAL#)	+	+
	Y61	Special color with Special Paint system (Provide RAL#)	+	+

+ Available • Standard – Not Available Pricing

Packaging

Frames 280 and larger will be bolted to an open wood pallet and wrapped in plastic to protect the finish. See standard packaging weights in dims in [Drawing section](#).

Stackable crate packing, **B07**, will have supported wooden slates on all sides surrounding the motor. This packing is available for frames up to 449 and provides additional protection during transport and allows for the motors to be stacked on the floor in a warehouse.

Export packing, **B09**, the motor will be secured into a fully enclosed wood crate. See Export box weights and dimensions in [Drawing section](#). Special packing, **B11**, will include B09+shock and tilt sensors.

Shipping weights and dimensions can be calculated using the standard packing weights and dimensions table combined with the motor information. The weights and dimensions listed in the tables do not include the weight and dimensions of the motor unless otherwise noted.

Paint

NEMA motors as standard are protected against corrosion (C2 category) and external influences with high-quality coatings based on (Alkyd Modified + Epoxy). If a higher corrosive class is required, a special paint system must be included.

Paint color will be Dark Chas standard. Special paint color, **Y60, Y61**, may be added for other RAL color. **Note: Y61** may only be used with one of the special paint systems (**N01, N02, N05, N06, N07**).

Motors can be provided with primer only, **N03**, to allow the customer to apply their own final paint in the field.

The 2 Parts Epoxy paint system, **N01**, offers excellent resistance to the corrosive action of chemical agents, prolonged weathering and to the action of direct sunlight.

The 3 Parts Epoxy paint system, **N02**, is an organic base of Epoxy Zinc, provides a high resistance to humid environments (saline or no-saline) but not for offshore ocean climate, excellent inhibitory capacity to corrosion, excellent resistance to abrasion, high temperatures (ambient temperatures >59°C) and to the most of industrial solvents (splashes). This Paint System is recommended to apply in high relative humidity environments (>60%).

2 Parts Epoxy paint system, **N06**, offers the same level of protection as **N02** at a reduced price and shorter process time.

The 3 parts epoxy (Coastal-Offshore High Salt) paint system, **N05**, is recommended for offshore installation, provides good chemical resistance to splash/spillage, fumes and immersion in neutral, fresh and salt water. Effectively protects the motor from corrosion resulting from industrial and marine exposures as it is safeguarding the environment.

2 Parts Epoxy paint system, **N07**, offers the same level of protection as N05 at a reduced price and shorter process time.

See [Technical Tables](#) for additional details.

2.1.2.9. Documentation

	Codes	Description	1LE6	1PC6 HPS
Short Codes	D05	Nameplate and Documentation in Spanish	+	+
	F00	Certificate of Compliance	+	+
	F01	Certificate of Origin - Stamped by Chamber of Commerce	+	+
	F03	Standard Performance Curve	+	+
	F04	Acceleration Time Calculation	+	+
	F05	Polarization Index	+	+
	F07	Curve Package at 100% and 80% voltage (S-T, PERF)	+	+
	F08	Shaft Torsional Analysis (includes shaft sketch)	+	+
	F09	Bearing L10 Calculation	+	+
	F40	Stall Time (Thermal Limit Curve)	+	+
	F42	Standard Dimension Sheet	+	+
	F43	Nonstandard Dimension Sheet	+	+
	F44	Conduit Box Dimension Sheet	+	+
	F45	Wiring Diagram	+	+
	F46	Instruction and Operation Manual	+	+
	F47	Renewal Parts	+	+
	F48	CAD Drawing (Dwg Format) Customer/Application Specific	+	+
	F49	Performance Data Sheets	+	+
	F50	Customer Specific Data Sheets	+	+
	F51	Shaft Profile Detail (included materials data)	+	+
F60	Visual Inspection Proof (Max 8X Photos)	+	+	
F70	Inspection Test Plan	+	+	
F71	Paint Report (thickness and adherence)	+	+	
F81	Advanced Document Package	+	+	
F82	Project Document Package	+	+	

+ Available • Standard – Not Available Pricing

ABB offers much of our documentation and certificates for download through our online configurator tool, ABB Motor Builder. This allows the data to be tailored to the motor configuration.

In addition to our online documentation, we also offer a wide variety of order specific documentation through order codes as individual documents or as documentation packages. Ordered documents be provided in ABB standard electronic format unless otherwise noted. Information that is proprietary to ABB will not be included in documentation supplied.

Drawings

Motor drawings can be provided in either pdf or CAD formats as specified in the purchase order. The standard drawing, **F42**, can be used for a standard F1 configuration with no special options. This drawing is also available for download through ABB Motor Builder at <https://motorbuilder.abb.com>.

The non-standard drawing in pdf format, **F43**, or in CAD format, **F48**, can be used for motors with mechanical modifications that would add on accessories or change the standard dimensions of the motor.

Conduit box drawing, **F44**, can be used for a standard conduit box drawing and auxiliary boxes.

Shaft Profile Detail, **F51**, provides a shaft profile drawing with limited dimensions and shaft material data.

Curves

Standard performance curves, **F03**, will include the motor calculated speed torque curve and calculated performance curve (Efficiency, Power Factor, and Amps Over percent of rated horsepower) at rated voltage. This curve is also available for download through ABB Motor Builder at <https://motorbuilder.abb.com>.

Stall Time Curve, **F40**, is a logarithmic curve of current (in percent of full load) over time. The curve will be shown for both hot and cold conditions and graphically illustrates the safe stall time.

Curves at 100% and 80% voltage, **F07**, will include speed torque curve and performance curves.

Data Sheets

Typical data sheet, **F49**, will provide an electrical data sheet for the motor ordered in ABB standard format.

Customer specific data sheet, **F50**, provides the customer with the project data sheet filled out by ABB engineering. The customer data sheet must be supplied in excel format at the time the purchase order is placed.

Special calculations and reports

Acceleration time calculation, **F04**, will be calculated based on the load inertia value provided by the customer. The inertia value must be provided with the PO.

Polarization Index, **F05**, provides a reference winding impedance to gauge deterioration of the winding insulation.

Shaft Torsional Analysis, **F08**, provides motor shaft torsional data for each step on the shaft.

Bearing L10 calculation, **F09**, calculates the estimated life of the bearings based on customer supplied application details. See [Bearings section](#) for minimum application details required.

Other documentation

Documentation and nameplates can be provided in Spanish, **D05**. This option will also include NOM on the nameplate.

Certificate of compliance, **F00**, can be issued to certify compliance with ISO standards.

Certificate of origin stamped by the Chamber of Commerce, **F01**, can be required when motors are exported for select countries.

Inspection Test Plan, **F70**, provides formal documentation of the factory standard tests and inspections.

Wiring diagram, **F45**, will provide a pdf copy of the motor wiring diagram for the motor ordered. This document is also available for download through ABB's Motor Builder at <https://motorbuilder.abb.com>.

Instruction and Operation Manual, **F46**, is general instructions for installation, operation and maintenance for NEMA motors. This document is also available for download through ABB Motor Builder at <https://motorbuilder.abb.com>.

Replacement parts list, **F47**, will provide part numbers and general descriptions for the following spare parts:

- Bearings, Fan, Fan housing, Conduit Box, Bearing housings (flange if applicable), and seals.

Visual inspection Proof, **F60**, provides up to 8 photos of the motor prior to shipment. Photos will include nameplate and tagging, at least 3 views of overall motors, and detail special features.

Paint Report, **F71**, provides a measure of paint thickness and overall paint adherence.

Additional specialized documentation and calculations may be offered by the factory through the ABB NEMA Motor Quotation Team.

Documentation packages

Order specific documentation packages provide many of the common documents required for special projects and OEMs packaged into a zip file. Additional documentation options may be added with order codes as required by the project.

Advanced Document Package, **F81**, will include:

- (F46) Instruction Operation Manual
- (F00) Certificate of Compliance
- (F49) Data Sheet
- Nameplate Drawing
- (F45) Connection Diagram
- (F07) Speed vs Torque / Current Curve and Performance Curve (at 80% and 100% Voltage)
- (F47) Spare Parts List
- (F43) Outline Drawing (pdf)

Project Documentation Package, **F82**, will include:

- (F46) Instruction Operation Manual
- (F00) Certificate of Compliance
- (F49) Data Sheet
- Nameplate Drawing
- (F45) Connection Diagram
- (F07) Speed vs Torque / Current Curve and Performance Curve (at 80% and 100% Voltage)
- (F47) Spare Parts List
- (F43) Outline Drawing (pdf)
- (F48) CAD Dimension drawing
- Thermal Limit Curve (at 80% and 100% Voltage)
- (F44) Terminal box drawing
- (F50) Customer specific data sheets
- (F70) ITP
- Hazardous Area Certs (UL or CSA)
- Details of Paint System

Tests

	Codes	Description	1LE6	1PC6 HPS
Short Codes	F10	Routine Test Report	+	+
	F12	Routine Test Report (Witnessed)	+	+
	F15	Complete Test	+	+
	F17	Complete Test (Witnessed)	+	+
	F20	Routine Test + Vibration	+	+
	F22	Routine Test + Vibration (Witnessed)	+	+
	F27	Performance Load Test (Curve Report)	+	+
	F30	Noise Test	+	+
	F32	Noise Test (Witnessed)	+	+
	F36	Routine Test Report of Electrical Duplicate Design	+	+
	F37	Type Test Report of Electrical Duplicate Design	+	+

+ Available • Standard – Not Available [Pricing](#)

Routine test, F10, F12

Routine test consists of the following items tested in accordance with IEEE standard 112.

- No Load Current
- No Load Speed
- Nominal Current at Locked Rotor
- Winding Resistance
- High Potential
- Bearings/Vibration Check

Routine test with vibration, F20, F22

Includes all tests from standard routine test with additional records of vibration testing. A hard copy of the Routine Test with vibration is included on all IEEE 841 compliant motors, adding **F20** will get you the test report in electronic format.

Test report of routine test is based on IEEE Std. 112 Form A-1 and includes complete nameplate information.

Electrical Duplicate Routine Test, **F36**, is an electronic copy of a test report of the same electrical design as the motor on order.

Noise test, F30, F32

Motors are tested according to IEEE 85 standard in unloaded condition only. Test report will be provided with sound pressure (Lp) and sound power (Lw) in octave bands of 125Hz, 250Hz, 500Hz, 1kHz, 2kHz, 4kHz, and 8kHz.

Complete test, F15, F17

Complete test consists of the following items tested in accordance with NEMA and IEEE-112 test standards.

- Full Load Heat Run
- Temperature Rise at F.L.
- Winding Resistance
- Rated F.L. Slip
- No Load Current
- Breakdown Torque
- Locked Rotor Torque-Amps
- High Potential Tests
- Efficiencies @ 100, 75, 50 Percent Load
- Power Factor @ 100, 75, 50 Percent Load

Test report of complete test is based on IEEE Std. Form A-2 and includes complete nameplate information.

Electrical Duplicate Complete Test, **F37**, is an electronic copy of a test report of the same electrical design as the motor on order.

Performance load test, F27

Performance Load Tests the motors at select points from 0-125% of the rated load recording speed, torque, current, power factor and efficiency, at rated voltage. Data is curve plotted, on ABB standard format. Foot mounted motors only.

Calculations and Typical Control Settings

Conversion Calculations

Power:

$$\text{Power (kW)} = \frac{\text{Torque (Nm)} \times \text{Speed (RPM)}}{9548.8}$$

$$\text{Power (HP)} = \frac{\text{Torque (Lb-Ft)} \times \text{Speed (RPM)}}{5250}$$

$$\text{kW} = \text{HP} \times 0.746$$

$$\text{HP} = \text{kW} \times 1.341$$

Torque

$$\text{Lb-Ft} = \text{Nm} \times .7376$$

$$\text{Nm} = \text{Lb-Ft} \times 1.359$$

Temperature

$$^{\circ}\text{C} = (^{\circ}\text{F} - 32) \times 5/9$$

$$^{\circ}\text{F} = (^{\circ}\text{C} \times 9/5) + 32$$

Inertia

$$\text{Lb. Ft.}^2 = \text{kgm}^2 \times 23.73$$

$$\text{Kgm}^2 = \text{Lb. Ft.}^2 \div 23.73$$

$$\text{Lb. Ft.}^2 = \text{GD2 (kgfm}^2) \times 5.933$$

Typical control settings for temperature monitoring devices

	Alarm	Trip
Winding RTDs	155°C	165°C
Bearing RTDs	110°C	120°C

2.2. Motor selection and pricing

2.2.1. Severe Duty Low Voltage NEMA Motors

Introduction

ABB Next Generation Severe Duty low voltage NEMA motors are designed and built to operate under harsh environments in the industry, including but not limited to petrochemical, pulp and paper mills and waste-water treatment. With expanded configurations and options, these motors are ideal for diverse applications, including fans, compressors, pumps, conveyors, hoists, and winders. These motors are designed to meet or exceed NEMA Premium® efficiency and are also available in NEMA Super Premium® efficiency³ as well as the most stringent industry standards of IEEE 841. Built for long, trouble-free life, they are backed by a 3-year warranty for SD200 and 5-year warranty for SD200 841.

Performance Specification



		SD200	SD200 841
HP Range	3600 RPM	125-800 HP	125-400 HP
	1800 RPM	125-800 HP	125-400 HP
	1200 RPM	100-600 HP	100-300 HP
	900 RPM	75-250 HP	
Frame Size	440T - 500	444T-5013	444T-L449T
Standard Voltage (3 phase)	460V, 60HZ	75-800 HP	75-400 HP
	575V, 60HZ	75-800 HP	75-400 HP
Efficiency	NEMA Premium® (MG1-Table 12-12)	75-500 HP	
Service Factor	1.15 @ 40°C	75-800 HP	
Insulation	440 Frame	Class H	
	500 Frame	Class H	
Temperature Rise	Class B	@ 1.0SF	
	Class F	@ 1.15SF	
Conduit Box (Oversized)	Oversized	Cast Iron	
Fan Cover		Cast Iron	
Cooling Fan	Bi-Directional	Polypropylene	
Rotor	Die Cast Aluminum	FS 440-500	
Ingress Protection	NEMA	IP55	IP56
Hazardous Location	Gas ²	CL 1, Div 2 Gr. A, B,C or D Temp. Code T3	
	Dust ⁴	CL 2, Div 2 Gr. F & G Temp. Code T3C	
Inverter Duty ⁵	Variable Torque VT 20:1	FS 440-500	
	Constant Torque CT 4:1	FS 444-449	
	Constant Torque CT 2:1	FS L449	
	Constant Torque CT 4:1	FS500, 4 Pole, 350-600HP	
	Constant Torque CT 3:1	FS500, 2 Pole, 400-600HP	
	Constant Torque CT 2:1	FS500, 4 Pole, 700-800HP	
		FS500, 6 pole, 350-600HP	
Constant Torque CT 35-60HZ	FS500, 2 Pole, 700-800HP		

1. IEEE841 Features above 500HP

3. NEMA Super Premium® efficiency on request with special quote

5. See Technical Tables for more details

2. FS 449 and FS L449: Temperature Code T2D

4. FS500 with option M25

Frame and end shields

ABB Severe Duty SD200 and SD200 841 NEMA motors feature cast iron frame, end shields, and an easy-to-access, diagonally-split, oversize terminal box. The terminal box is provided with a neoprene gasket and includes a heavy-duty ground lug and non-wicking clearly and permanently marked leads.

These characteristics, its high strength zinc-plated hardware, epoxy paint and stainless-steel nameplate provide exceptional structural integrity and resistance to rust and corrosion, making them suitable for severe duty applications in harsh environments.

Rotor and stator windings

A unique offset rotor bar design provides improved efficiency, while larger bars and end rings reduce resistance for lower rotor losses. Each die cast aluminum rotor assembly is dynamically balanced for extended bearing life and includes a high-strength carbon steel (C1045) shaft for maximum rotor performance.

The stator is manufactured with premium electrical C5 grade steel lamination and copper electrical magnet wire that furthers the reduction in losses.

Insulation

The proprietary Class H non-hygroscopic insulation system is rated for 180 deg C, NEMA Class B temperature rise, providing extra margin of thermal life. The varnish system application ensures maximum wire penetration to provide protection from moisture, corrosion, and electrical shock. This insulation system meets or exceeds NEMA MG1 Part 31 making the motors suitable for variable speed drives in constant torque (as noted) and variable torque (20:1). All windings are tested for CIV.

Cooling System

A non-sparking, bi-directional fan is locked and keyed to the shaft. Its low-inertia design reduces windage losses, improves airflow, reduces noise, and provides dependable cooling. Cast Iron fan covers are provided for all frames sizes.

Bearings

Single shielded bearings are used for better bearing protection against contaminants.

2.2.1.1. SD200



**SD200 | Eff: NEMA Premium | 2 Pole | 460V | Ball Bearing | Short-Shaft
Without Winding Protection**

Power HP	Speed RPM	NEMA Frame	Voltage	Base Part Number	Stock	List Price	Eff %	Weight (lbs)
125	3600	444TS	460	1LE6321-4FA11-2AA1	+	15730	95	1462
150	3600	445TS	460	1LE6321-4FA21-2AA1	+	18900	96	1557
200	3600	447TS	460	1LE6321-4GA11-2AA1	+	23900	96	1819
250	3600	449TS	460	1LE6321-4GA21-2AA1	+	30150	96	2061
300	3600	449TS	460	1LE6321-4GA31-2AA1	+	41270	96	2183
350	3600	L449TS	460	1LE6321-4HA11-2AA1	+	42410	96	2680
400	3600	L449TS	460	1LE6321-4HA21-2AA1	+	52890	96	2797
400	3600	509S	460	1LE6321-5EA11-2AA1		55650	96	4219
450	3600	5010S	460	1LE6321-5EA21-2AA1	+	56780	96	4357
500	3600	5011S	460	1LE6321-5EA81-2AA1		57530	96	4504
600	3600	5011S	460	1LE6321-5EA01-2AA1		64200	97	4936
700	3600	5013S	460	1LE6321-5FA71-2AA1		73880	97	5538
800	3600	5013S	460	1LE6321-5FA81-2AA1		77580	97	5798

**SD200 | Eff: NEMA Premium | 4 Pole | 460V | Ball Bearing | Long Shaft
Without Winding Protection**

Power HP	Speed RPM	NEMA Frame	Voltage	Base Part Number	Stock	List Price	Eff %	Weight (lbs)
125	1800	444T	460	1LE6321-4BB11-2AA1	+	14660	95	1543
150	1800	445T	460	1LE6321-4BB21-2AA1	+	17050	96	1575
200	1800	447T	460	1LE6321-4CB11-2AA1	+	20730	96	1830
250	1800	449T	460	1LE6321-4CB21-2AA1	+	26010	96	2138
300	1800	449T	460	1LE6321-4CB31-2AA1	+	30340	96	2250
350	1800	L449T	460	1LE6321-4DB11-2AA1	+	39390	96	2598
400	1800	L449T	460	1LE6321-4DB21-2AA1	+	49140	96	2670
400	1800	509	460	1LE6321-5AB11-2AA1		54380	97	4105
450	1800	5010	460	1LE6321-5AB21-2AA1	+	56120	97	4302
500	1800	5011	460	1LE6321-5AB81-2AA1	+	56960	97	4509
600	1800	5011	460	1LE6321-5AB01-2AA1		64420	97	4993
700	1800	5013	460	1LE6321-5BB71-2AA1		75990	97	5592
800	1800	5013	460	1LE6321-5BB81-2AA1		79170	97	5863

**SD200 | Eff: NEMA Premium | 4 Pole | 460V | Ball Bearing | Short Shaft
Without Winding Protection**

Power HP	Speed RPM	NEMA Frame	Voltage	Base Part Number	Stock	List Price	Eff %	Weight (lbs)
125	1800	444TS	460	1LE6321-4FB11-2AA1	+	14660	95	1499
150	1800	445TS	460	1LE6321-4FB21-2AA1	+	17050	96	1576
200	1800	447TS	460	1LE6321-4GB11-2AA1	+	20730	96	1797
250	1800	449TS	460	1LE6321-4GB21-2AA1	+	26010	96	2083
300	1800	449TS	460	1LE6321-4GB31-2AA1	+	30340	96	2183
350	1800	L449TS	460	1LE6321-4HB11-2AA1	+	39390	96	2574
400	1800	L449TS	460	1LE6321-4HB21-2AA1		49140	96	2685
400	1800	509S	460	1LE6321-5EB11-2AA1		54380	97	4105
450	1800	5010S	460	1LE6321-5EB21-2AA1		56120	97	4302
500	1800	5011S	460	1LE6321-5EB81-2AA1		56960	97	4509
600	1800	5011S	460	1LE6321-5EB01-2AA1		64420	97	4993
700	1800	5013S	460	1LE6321-5FB71-2AA1		75990	97	5592
800	1800	5013S	460	1LE6321-5FB81-2AA1		79170	97	5863

**SD200 | Eff: NEMA Premium | 4 Pole | 460V | Roller Bearing | Long Shaft
Without Winding Protection**

Power HP	Speed RPM	NEMA Frame	Voltage	Base Part Number	Stock	List Price	Eff %	Weight (lbs)
125	1800	R444T	460	1LE6321-4SB11-2AA1	+	15280	95	1521
150	1800	R445T	460	1LE6321-4SB21-2AA1	+	17660	96	1588
200	1800	R447T	460	1LE6321-4TB11-2AA1	+	21350	96	1841
250	1800	R449T	460	1LE6321-4TB21-2AA1	+	26630	96	2150
300	1800	R449T	460	1LE6321-4TB31-2AA1	+	30950	96	2216
350	1800	RL449T	460	1LE6321-4UB11-2AA1	+	40010	96	2632
400	1800	RL449T	460	1LE6321-4UB21-2AA1		49750	96	2734
400	1800	R509	460	1LE6321-5RB11-2AA1		55630	97	4105
450	1800	R5010	460	1LE6321-5RB21-2AA1	MOD	57370	97	4302
500	1800	R5011	460	1LE6321-5RB81-2AA1	MOD	58210	97	4509
600	1800	R5011	460	1LE6321-5RB01-2AA1		65680	97	4993
700	1800	R5013	460	1LE6321-5SB71-2AA1		77240	97	5592
800	1800	R5013	460	1LE6321-5SB81-2AA1		80420	97	5863

**SD200 | Eff: NEMA Premium | 6 Pole | 460V | Ball Bearing | Long Shaft
Without Winding Protection**

Power HP	Speed RPM	NEMA Frame	Voltage	Base Part Number	Stock	List Price	Eff %	Weight (lbs)
100	1200	444T	460	1LE6321-4BC11-2AA1	+	15020	95	1465
125	1200	445T	460	1LE6321-4BC21-2AA1	+	18440	95	1543
150	1200	447T	460	1LE6321-4CC11-2AA1	+	20630	96	1795
200	1200	449T	460	1LE6321-4CC21-2AA1	+	25260	96	2125
250	1200	449T	460	1LE6321-4CC31-2AA1	+	27480	96	2283
300	1200	L449T	460	1LE6321-4DC11-2AA1		34400	96	2830
350	1200	5010	460	1LE6321-5AC21-2AA1		56690	96	4387
400	1200	5011	460	1LE6321-5AC81-2AA1		59920	96	4529

Power HP	Speed RPM	NEMA Frame	Voltage	Base Part Number	Stock	List Price	Eff %	Weight (lbs)
450	1200	L5011	460	1LE6321-5BC31-2AA1		68490	96	5083
500	1200	5012	460	1LE6321-5BC51-2AA1		72600	96	5289
600	1200	5013	460	1LE6321-5BC71-2AA1		79170	96	5391

SD200 | Eff: NEMA Premium | 6 Pole | 460V | Ball Bearing | Short Shaft Without Winding Protection

Power HP	Speed RPM	NEMA Frame	Voltage	Base Part Number	Stock	List Price	Eff %	Weight (lbs)
100	1200	444TS	460	1LE6321-4FC11-2AA1		15020	95	1407
125	1200	445TS	460	1LE6321-4FC21-2AA1		18440	95	1495
150	1200	447TS	460	1LE6321-4GC11-2AA1		20630	96	1747
200	1200	449TS	460	1LE6321-4GC21-2AA1		25260	96	2075
250	1200	449TS	460	1LE6321-4GC31-2AA1		27480	96	2234
300	1200	L449TS	460	1LE6321-4HC11-2AA1		34400	96	2798
350	1200	5010S	460	1LE6321-5EC21-2AA1		54760	96	4387
400	1200	5011S	460	1LE6321-5EC81-2AA1		59920	96	4529
450	1200	L5011S	460	1LE6321-5FC31-2AA1		63670	96	5083
500	1200	5012S	460	1LE6321-5FC51-2AA1		70670	96	5289
600	1200	5013S	460	1LE6321-5FC71-2AA1		79170	96	5391

SD200 | Eff: NEMA Premium | 6 Pole | 460V | Roller Bearing | Long Shaft Without Winding Protection

Power HP	Speed RPM	NEMA Frame	Voltage	Base Part Number	Stock	List Price	Eff %	Weight (lbs)
100	1200	R444T	460	1LE6321-4SC11-2AA1	+	15640	95	1468
125	1200	R445T	460	1LE6321-4SC21-2AA1	+	19060	95	1555
150	1200	R447T	460	1LE6321-4TC11-2AA1	+	21250	96	1807
200	1200	R449T	460	1LE6321-4TC21-2AA1	+	25880	96	2138
250	1200	R449T	460	1LE6321-4TC31-2AA1	+	28100	96	2295
300	1200	RL449T	460	1LE6321-4UC11-2AA1	+	35010	96	2845
350	1200	R5010	460	1LE6321-5RC21-2AA1		57940	96	4387
400	1200	R5011	460	1LE6321-5RC81-2AA1		61170	96	4529
450	1200	RL5011	460	1LE6321-5SC31-2AA1		69740	96	5083
500	1200	R5012	460	1LE6321-5SC51-2AA1		73850	96	5289
600	1200	R5013	460	1LE6321-5SC71-2AA1		80420	96	5390

NEMA Premium is a certification mark of the National Electrical Manufacturer's Association

**SD200 | Eff: NEMA Premium | 8 Pole | 460V | Ball Bearing | Long Shaft
Without Winding Protection**

Power HP	Speed RPM	NEMA Frame	Voltage	Base Part Number	Stock	List Price	Eff %	Weight (lbs)
75	900	444T	460	1LE6321-4BD11-2AA1		17030	94	1414
100	900	445T	460	1LE6321-4BD21-2AA1		21050	94	1495
125	900	447T	460	1LE6321-4CD11-2AA1		22330	94	1720
150	900	449T	460	1LE6321-4CD21-2AA1		28520	94	1967
200	900	L449T	460	1LE6321-4DD11-2AA1		34910	95	2579
250	900	L449T	460	1LE6321-4DD21-2AA1		41250	95	2853

**SD200 | Eff: NEMA Premium | 8 Pole | 460V | Ball Bearing | Short Shaft
Without Winding Protection**

Power HP	Speed RPM	NEMA Frame	Voltage	Base Part Number	Stock	List Price	Eff %	Weight (lbs)
75	900	444TS	460	1LE6321-4FD11-2AA1		17030	94	1402
100	900	445TS	460	1LE6321-4FD21-2AA1		21050	94	1482
125	900	447TS	460	1LE6321-4GD11-2AA1		22330	94	1282
150	900	449TS	460	1LE6321-4GD21-2AA1		28520	94	1958
200	900	L449TS	460	1LE6321-4HD11-2AA1		34910	95	2506
250	900	L449TS	460	1LE6321-4HD21-2AA1		41250	95	2853

**SD200 | Eff: NEMA Premium | 8 Pole | 460V | Roller Bearing | Long Shaft
Without Winding Protection**

Power HP	Speed RPM	NEMA Frame	Voltage	Base Part Number	Stock	List Price	Eff %	Weight (lbs)
75	900	R444T	460	1LE6321-4SD11-2AA1	+	17650	94	1425
100	900	R445T	460	1LE6321-4SD21-2AA1	+	21670	94	1507
125	900	R447T	460	1LE6321-4TD11-2AA1	+	22960	94	1733
150	900	R449T	460	1LE6321-4TD21-2AA1	+	29140	94	1969
200	900	RL449T	460	1LE6321-4UD11-2AA1	+	35530	95	2577
250	900	RL449T	460	1LE6321-4UD21-2AA1		41870	95	2855

**SD200 | Eff: NEMA Premium | 2 Pole | 575 V | Ball Bearing | Short Shaft
Without Winding Protection**

Power HP	Speed RPM	NEMA Frame	Voltage	Base Part Number	Stock	List Price	Eff %	Weight (lbs)
125	3600	444TS	575	1LE6321-4FA11-3AA1		15730	95	1462
150	3600	445TS	575	1LE6321-4FA21-3AA1		18900	96	1557
200	3600	447TS	575	1LE6321-4GA11-3AA1		23900	96	1819
250	3600	449TS	575	1LE6321-4GA21-3AA1		30150	96	2061
300	3600	449TS	575	1LE6321-4GA31-3AA1		41270	96	2183
350	3600	L449TS	575	1LE6321-4HA11-3AA1		42410	96	2680
400	3600	L449TS	575	1LE6321-4HA21-3AA1		52890	96	2797
400	3600	509S	575	1LE6321-5EA11-3AA1		58930	96	4219
450	3600	5010S	575	1LE6321-5EA21-3AA1		60060	96	4357
500	3600	5011S	575	1LE6321-5EA81-3AA1		60810	96	4504
600	3600	5011S	575	1LE6321-5EA01-3AA1		67480	97	4936
700	3600	5013S	575	1LE6321-5FA71-3AA1		77160	97	5538
800	3600	5013S	575	1LE6321-5FA81-3AA1		80860	97	5798

**SD200 | Eff: NEMA Premium | 4 Pole | 575V | Ball Bearing | Long Shaft
Without Winding Protection**

Power HP	Speed RPM	NEMA Frame	Voltage	Base Part Number	Stock	List Price	Eff %	Weight (lbs)
125	1800	444T	575	1LE6321-4BB11-3AA1		14660	95	1543
150	1800	445T	575	1LE6321-4BB21-3AA1	+	17050	96	1575
200	1800	447T	575	1LE6321-4CB11-3AA1		20730	96	1830
250	1800	449T	575	1LE6321-4CB21-3AA1		26010	96	2138
300	1800	449T	575	1LE6321-4CB31-3AA1		30340	96	2250
350	1800	L449T	575	1LE6321-4DB11-3AA1		39390	96	2598
400	1800	L449T	575	1LE6321-4DB21-3AA1		49140	96	2670
400	1800	509	575	1LE6321-5AB11-3AA1		57660	97	4105
450	1800	509	575	1LE6321-5AB21-3AA1		59400	97	4302
500	1800	5011	575	1LE6321-5AB81-3AA1		60240	97	4509
600	1800	5011	575	1LE6321-5AB01-3AA1		67700	97	4993
700	1800	5013	575	1LE6321-5BB71-3AA1		79270	97	5592

**SD200 | Eff: NEMA Premium | 4 Pole | 575V | Ball Bearing | Short Shaft
Without Winding Protection**

Power HP	Speed RPM	NEMA Frame	Voltage	Base Part Number	Stock	List Price	Eff %	Weight (lbs)
125	1800	444TS	575	1LE6321-4FB11-3AA1		14660	95	1499
150	1800	445TS	575	1LE6321-4FB21-3AA1		17050	96	1576
200	1800	447TS	575	1LE6321-4GB11-3AA1		20730	96	1797
250	1800	449TS	575	1LE6321-4GB21-3AA1		26010	96	2083
300	1800	449TS	575	1LE6321-4GB31-3AA1		30340	96	2183
350	1800	L449TS	575	1LE6321-4HB11-3AA1		39390	96	2574
400	1800	L449TS	575	1LE6321-4HB21-3AA1		49140	96	2685
400	1800	509S	575	1LE6321-5EB11-3AA1		57660	97	4105
450	1800	509S	575	1LE6321-5EB21-3AA1		59400	97	4302

Power HP	Speed RPM	NEMA Frame	Voltage	Base Part Number	Stock	List Price	Eff %	Weight (lbs)
500	1800	5011S	575	1LE6321-5EB81-3AA1		60240	97	4509
600	1800	5011S	575	1LE6321-5EB01-3AA1		67480	97	4993
700	1800	5013S	575	1LE6321-5FB71-3AA1		79270	97	5592

SD200 | Eff: NEMA Premium | 4 Pole | 575V | Roller Bearing | Long Shaft Without Winding Protection

Power HP	Speed RPM	NEMA Frame	Voltage	Base Part Number	Stock	List Price	Eff %	Weight (lbs)
125	1800	R444T	575	1LE6321-4SB11-3AA1		15280	95	1521
150	1800	R445T	575	1LE6321-4SB21-3AA1		17660	96	1588
200	1800	R447T	575	1LE6321-4TB11-3AA1		21350	96	1841
250	1800	R449T	575	1LE6321-4TB21-3AA1		26630	96	2150
300	1800	R449T	575	1LE6321-4TB31-3AA1		30950	96	2216
350	1800	RL449T	575	1LE6321-4UB11-3AA1		40010	96	2632
400	1800	RL449T	575	1LE6321-4UB21-3AA1		49750	96	2734
400	1800	R509	575	1LE6321-5RB11-3AA1		58910	97	4105
450	1800	R509	575	1LE6321-5RB21-3AA1		60650	97	4302
500	1800	R5011	575	1LE6321-5RB81-3AA1		61490	97	4509
600	1800	R5011	575	1LE6321-5RB01-3AA1		68960	97	4993
700	1800	R5013	575	1LE6321-5SB71-3AA1		80520	97	5592

SD200 | Eff: NEMA Premium | 6 Pole | 575V | Ball Bearing | Long Shaft Without Winding Protection

Power HP	Speed RP<	NEMA Frame	Voltage	Base Part Number	Stock	List Price	Eff %	Weight (lbs)
100	1200	444T	575	1LE6321-4BC11-3AA1		15020	95	1465
125	1200	445T	575	1LE6321-4BC21-3AA1		18440	95	1543
150	1200	447T	575	1LE6321-4CC11-3AA1		20630	96	1795
200	1200	449T	575	1LE6321-4CC21-3AA1		25260	96	2125
250	1200	449T	575	1LE6321-4CC31-3AA1		27480	96	2283
300	1200	L449T	575	1LE6321-4DC11-3AA1		34400	96	2830
350	1200	5010	575	1LE6321-5AC21-3AA1		59970	96	4387
400	1200	5011	575	1LE6321-5AC81-3AA1		63200	96	4529
450	1200	L5011	575	1LE6321-5BC31-3AA1		71770	96	5083
500	1200	5012	575	1LE6321-5BC51-3AA1		75880	96	5289
600	1200	5013	575	1LE6321-5BC71-3AA1		82450	96	5391

**SD200 | Eff: NEMA Premium | 6 Pole | 575V | Ball Bearing | Short Shaft
Without Winding Protection**

Power HP	Speed RPM	NEMA Frame	Voltage	Base Part Number	Stock	List Price	Eff %	Weight (lbs)
100	1200	444TS	575	1LE6321-4FC11-3AA1		15020	95	1407
125	1200	445TS	575	1LE6321-4FC21-3AA1		18440	95	1495
150	1200	447TS	575	1LE6321-4GC11-3AA1		20630	96	1747
200	1200	449TS	575	1LE6321-4GC21-3AA1		25260	96	2075
250	1200	449TS	575	1LE6321-4GC31-3AA1		27480	96	2234
300	1200	L449TS	575	1LE6321-4HC11-3AA1		34400	96	2798
350	1200	5010S	575	1LE6321-5EC21-3AA1		58040	96	4387
400	1200	5011S	575	1LE6321-5EC81-3AA1		63200	96	4529
450	1200	L5011S	575	1LE6321-5FC31-3AA1		66950	96	5083
500	1200	5012S	575	1LE6321-5FC51-3AA1		73950	96	5289
600	1200	5013S	575	1LE6321-5FC71-3AA1		82450	96	5391

**SD200 | Eff: NEMA Premium | 6 Pole | 575V | Roller Bearing | Long Shaft
Without Winding Protection**

Power HP	Speed RPM	NEMA Frame	Voltage	Base Part Number	Stock	List Price	Eff %	Weight (lbs)
100	1200	R444T	575	1LE6321-4SC11-3AA1		15640	95	1468
125	1200	R445T	575	1LE6321-4SC21-3AA1		19060	95	1555
150	1200	R447T	575	1LE6321-4TC11-3AA1		21250	96	1807
200	1200	R449T	575	1LE6321-4TC21-3AA1		25880	96	2138
250	1200	R449T	575	1LE6321-4TC31-3AA1		28100	96	2295
300	1200	RL449T	575	1LE6321-4UC11-3AA1		35010	96	2845
350	1200	R5010	575	1LE6321-5RC21-3AA1		61220	96	4387

**SD200 | Eff: NEMA Premium | 8 Pole | 575V | Ball Bearing | Long Shaft
Without Winding Protection**

Power HP	Speed RPM	NEMA Frame	Voltage	Base Part Number	Stock	List Price	Eff %	Weight (lbs)
75	900	444T	575	1LE6321-4BD11-3AA1		17030	94	1414
100	900	445T	575	1LE6321-4BD21-3AA1		21050	94	1495
125	900	447T	575	1LE6321-4CD11-3AA1		22330	94	1720
150	900	449T	575	1LE6321-4CD21-3AA1		28520	94	1967
200	900	L449T	575	1LE6321-4DD11-3AA1		34910	95	2579
250	900	L449T	575	1LE6321-4DD21-3AA1		41250	95	2853

**SD200 | Eff: NEMA Premium | 8 Pole | 575V | Ball Bearing | Short Shaft
Without Winding Protection**

Power HP	Speed RPM	NEMA Frame	Voltage	Base Part Number	Stock	List Price	Eff %	Weight (lbs)
75	900	444TS	575	1LE6321-4FD11-3AA1		17030	94	1402
100	900	445TS	575	1LE6321-4FD21-3AA1		21050	94	1482
125	900	447TS	575	1LE6321-4GD11-3AA1		22330	94	1282
150	900	449TS	575	1LE6321-4GD21-3AA1		28520	94	1958
200	900	L449TS	575	1LE6321-4HD11-3AA1		34910	95	2506
250	900	L449TS	575	1LE6321-4HD21-3AA1		41250	95	2853

**SD200 | Eff: NEMA Premium | 8 Pole | 575V | Roller Bearing | Long Shaft
Without Winding Protection**

Power HP	Speed RPM	NEMA Frame	Voltage	Base Part Number	Stock	List Price	Eff %	Weight (lbs)
75	900	R444T	575	1LE6321-4SD11-3AA1	+	17650	94	1425
100	900	R445T	575	1LE6321-4SD21-3AA1	+	21670	94	1507
125	900	R447T	575	1LE6321-4TD11-3AA1	+	22960	94	1733
150	900	R449T	575	1LE6321-4TD21-3AA1	+	29140	94	1969
200	900	RL449T	575	1LE6321-4UD11-3AA1	+	35530	95	2577
250	900	RL449T	575	1LE6321-4UD21-3AA1		41870	95	2855

NEMA Premium is a certification mark of the National Electrical Manufacturer's Association

2.2.1.2. SD200 841

**SD200 841 | Eff: NEMA Premium | 2 Pole | 460V | Ball Bearing | Short Shaft
Without Winding Protection**

Power HP	Speed RPM	NEMA Frame	Voltage	Base Part Number	Stock	List Price	Eff %	Weight (lbs)
125	3600	444TS	460	1LE6322-4FA11-2AA1	+	18350	95	1460
150	3600	445TS	460	1LE6322-4FA21-2AA1	+	21460	96	1555
200	3600	447TS	460	1LE6322-4GA11-2AA1	+	26910	96	1842
250	3600	449TS	460	1LE6322-4GA21-2AA1	+	34250	96	2048
300	3600	449TS	460	1LE6322-4GA31-2AA1	+	43490	96	2155
350	3600	L449TS	460	1LE6322-4HA11-2AA1		52030	96	2688
400	3600	L449TS	460	1LE6322-4HA21-2AA1	+	58350	96	2863

**SD200 841 | Eff: NEMA Premium | 4 Pole | 460V | Ball Bearing | Long Shaft
Without Winding Protection**

Power HP	Speed RPM	NEMA Frame	Voltage	Base Part Number	Stock	List Price	Eff %	Weight (lbs)
125	1800	444T	460	1LE6322-4BB11-2AA1	+	16900	95	1480
150	1800	445T	460	1LE6322-4BB21-2AA1	+	19120	96	1568
200	1800	447T	460	1LE6322-4CB11-2AA1	+	23250	96	1830
250	1800	449T	460	1LE6322-4CB21-2AA1	+	29470	96	2150
300	1800	449T	460	1LE6322-4CB31-2AA1		39960	96	2119
350	1800	L449T	460	1LE6322-4DB11-2AA1		48180	96	2598
400	1800	L449T	460	1LE6322-4DB21-2AA1		54050	96	2670

**SD200 841 | Eff: NEMA Premium | 4 Pole | 460V | Ball Bearing | Short Shaft
Without Winding Protection**

Power HP	Speed RPM	NEMA Frame	Voltage	Base Part Number	Stock	List Price	Eff %	Weight (lbs)
125	1800	444TS	460	1LE6322-4FB11-2AA1	+	16900	95	1520
150	1800	445TS	460	1LE6322-4FB21-2AA1	+	19120	96	1600
200	1800	447TS	460	1LE6322-4GB11-2AA1	+	23250	96	1820
250	1800	449TS	460	1LE6322-4GB21-2AA1	+	29470	96	2095
300	1800	449TS	460	1LE6322-4GB31-2AA1		39960	96	2170
350	1800	L449TS	460	1LE6322-4HB11-2AA1		48180	96	2598
400	1800	L449TS	460	1LE6322-4HB21-2AA1		54050	96	2685

**SD200 841 | Eff: NEMA Premium | 4 Pole | 460V | Roller Bearing | Long Shaft
Without Winding Protection**

Power HP	Speed RPM	NEMA Frame	Voltage	Base Part Number	Stock	List Price	Eff %	Weight (lbs)
125	1800	R444T	460	1LE6322-4SB11-2AA1	+	17520	95	1492
150	1800	R445T	460	1LE6322-4SB21-2AA1	+	19740	96	1581
200	1800	R447T	460	1LE6322-4TB11-2AA1	+	23870	96	1865
250	1800	R449T	460	1LE6322-4TB21-2AA1	+	30090	96	2150
300	1800	R449T	460	1LE6322-4TB31-2AA1		40580	96	2097
350	1800	RL449T	460	1LE6322-4UB11-2AA1		48840	96	2642
400	1800	RL449T	460	1LE6322-4UB21-2AA1		54670	96	2670

**SD200 841 | Eff: NEMA Premium | 6 Pole | 460V | Ball Bearing | Long Shaft
Without Winding Protection**

Power HP	Speed RPM	NEMA Frame	Voltage	Base Part Number	Stock	List Price	Eff %	Weight (lbs)
100	1200	444T	460	1LE6322-4BC11-2AA1	+	17400	95	1452
125	1200	445T	460	1LE6322-4BC21-2AA1	+	20990	95	1540
150	1200	447T	460	1LE6322-4CC11-2AA1	+	23050	96	1792
200	1200	449T	460	1LE6322-4CC21-2AA1	+	27960	96	2123
250	1200	449T	460	1LE6322-4CC31-2AA1	+	30730	96	2280
300	1200	L449T	460	1LE6322-4DC11-2AA1	+	41260	96	2830

**SD200 841 | Eff: NEMA Premium | 6 Pole | 460V | Ball Bearing | Short Shaft
Without Winding Protection**

Power HP	Speed RPM	NEMA Frame	Voltage	Base Part Number	Stock	List Price	Eff %	Weight (lbs)
100	1200	444TS	460	1LE6322-4FC11-2AA1		17400	95	1454
125	1200	445TS	460	1LE6322-4FC21-2AA1		20990	95	1494
150	1200	447TS	460	1LE6322-4GC11-2AA1		23050	96	1746
200	1200	449TS	460	1LE6322-4GC21-2AA1		27960	96	2075
250	1200	449TS	460	1LE6322-4GC31-2AA1		30730	96	2235
300	1200	L449TS	460	1LE6322-4HC11-2AA1		41260	96	2797

**SD200 841 | Eff: NEMA Premium | 6 Pole | 460V Roller Bearing | Long Shaft
Without Winding Protection**

Power HP	Speed RPM	NEMA Frame	Voltage	Base Part Number	Stock	List Price	Eff %	Weight (lbs)
100	1200	R444T	460	1LE6322-4SC11-2AA1	+	18020	95	1465
125	1200	R445T	460	1LE6322-4SC21-2AA1	+	21610	95	1552
150	1200	R447T	460	1LE6322-4TC11-2AA1	+	23670	96	1804
200	1200	R449T	460	1LE6322-4TC21-2AA1	+	28580	96	2135
250	1200	R449T	460	1LE6322-4TC31-2AA1	+	31350	96	2292
300	1200	RL449T	460	1LE6322-4UC11-2AA1	+	41870	96	2855

**SD200 841 | Eff: NEMA Premium | 8 Pole | 460V | Ball Bearing | Long Shaft
Without Winding Protection**

Power HP	Speed RPM	NEMA Frame	Voltage	Base Part Number	Stock	List Price	Eff %	Weight (lbs)
75	900	444T	460	1LE6322-4BD11-2AA1		20240	94	1411
100	900	445T	460	1LE6322-4BD21-2AA1		24810	94	1494
125	900	447T	460	1LE6322-4CD11-2AA1		25480	94	1718
150	900	449T	460	1LE6322-4CD21-2AA1		32580	94	1967
200	900	L449T	460	1LE6322-4DD11-2AA1		47060	95	2579
250	900	L449T	460	1LE6322-4DD21-2AA1		51500	95	2853

**SD200 841 | Eff: NEMA Premium | 8 Pole | 460V | Ball Bearing | Short Shaft
Without Winding Protection**

Power HP	Speed RPM	NEMA Frame	Voltage	Base Part Number	Stock	List Price	Eff %	Weight (lbs)
75	900	444TS	460	1LE6322-4FD11-2AA1		20240	94	1402
100	900	445TS	460	1LE6322-4FD21-2AA1		24810	94	1482
125	900	447TS	460	1LE6322-4GD11-2AA1		25480	94	1280
150	900	449TS	460	1LE6322-4GD21-2AA1		32580	94	1958
200	900	L449TS	460	1LE6322-4HD11-2AA1		47060	95	2506
250	900	L449TS	460	1LE6322-4HD21-2AA1		51500	95	2853

**SD200 841 | Eff: NEMA Premium | 8 Pole | 460V | Roller Bearing | Long Shaft
Without Winding Protection**

Power HP	Speed RPM	NEMA Frame	Voltage	Base Part Number	Stock	List Price	Eff %	Weight (lbs)
75	900	R444T	460	1LE6322-4SD11-2AA1		20870	94	1423
100	900	R445T	460	1LE6322-4SD21-2AA1		25430	94	1505
125	900	R447T	460	1LE6322-4TD11-2AA1		26100	94	1730
150	900	R449T	460	1LE6322-4TD21-2AA1		33200	94	1966
200	900	RL449T	460	1LE6322-4UD11-2AA1		47060	95	2579
250	900	RL449T	460	1LE6322-4UD21-2AA1		51500	95	2583

**SD200 841 | Eff: NEMA Premium | 2 Pole | 575V | Ball Bearing | Short Shaft
Without Winding Protection**

Power HP	Speed RPM	NEMA Frame	Voltage	Base Part Number	Stock	List Price	Eff %	Weight (lbs)
125	3600	444TS	575	1LE6322-4FA11-3AA1		18350	95	1460
150	3600	445TS	575	1LE6322-4FA21-3AA1		21460	96	1555
200	3600	447TS	575	1LE6322-4GA11-3AA1		26910	96	1842
250	3600	449TS	575	1LE6322-4GA21-3AA1		34250	96	2048
300	3600	449TS	575	1LE6322-4GA31-3AA1		43490	96	2155
350	3600	L449TS	575	1LE6322-4HA11-3AA1		52030	96	2688
400	3600	L449TS	575	1LE6322-4HA21-3AA1		58350	96	2863

**SD200 841 | Eff: NEMA Premium | 4 Pole | 575V | Ball Bearing | Long Shaft
Without Winding Protection**

Power HP	Speed RPM	NEMA Frame	Voltage	Base Part Number	Stock	List Price	Eff %	Weight (lbs)
125	1800	444T	575	1LE6322-4BB11-3AA1	+	16900	95	1480
150	1800	445T	575	1LE6322-4BB21-3AA1	+	19120	96	1568
200	1800	447T	575	1LE6322-4CB11-3AA1	+	23250	96	1830
250	1800	449T	575	1LE6322-4CB21-3AA1	+	29470	96	2150
300	1800	449T	575	1LE6322-4CB31-3AA1		39960	96	2119
350	1800	L449T	575	1LE6322-4DB11-3AA1		48180	96	2598
400	1800	L449T	575	1LE6322-4DB21-3AA1		54050	96	2670

**SD200 841 | Eff: NEMA Premium | 4 Pole | 575V | Ball Bearing | Short Shaft
Without Winding Protection**

Power HP	Speed RPM	NEMA Frame	Voltage	Base Part Number	Stock	List Price	Eff %	Weight (lbs)
125	1800	444TS	575	1LE6322-4FB11-3AA1		16900	95	1520
150	1800	445TS	575	1LE6322-4FB21-3AA1		19120	96	1600
200	1800	447TS	575	1LE6322-4GB11-3AA1		23250	96	1820
250	1800	449TS	575	1LE6322-4GB21-3AA1		29470	96	2095
300	1800	449TS	575	1LE6322-4GB31-3AA1		39960	96	2170
350	1800	L449TS	575	1LE6322-4HB11-3AA1		48180	96	2598
400	1800	L449TS	575	1LE6322-4HB21-3AA1		54050	96	2685

**SD200 841 | Eff: NEMA Premium | 4 Pole | 575V | Roller Bearing | Long Shaft
Without Winding Protection**

Power HP	Speed RPM	NEMA Frame	Voltage	Base Part Number	Stock	List Price	Eff %	Weight (lbs)
125	1800	R444T	575	1LE6322-4SB11-3AA1		17520	95	1492
150	1800	R445T	575	1LE6322-4SB21-3AA1	+	19740	96	1581
200	1800	R447T	575	1LE6322-4TB11-3AA1		23870	96	1865
250	1800	R449T	575	1LE6322-4TB21-3AA1		30090	96	2150
300	1800	R449T	575	1LE6322-4TB31-3AA1		40580	96	2097
350	1800	RL449T	575	1LE6322-4UB11-3AA1		48840	96	2642
400	1800	RL449T	575	1LE6322-4UB21-3AA1		54670	96	2670

**SD200 841 | Eff: NEMA Premium | 6 Pole | 575V | Ball Bearing | Long Shaft
Without Winding Protection**

Power HP	Speed RPM	NEMA Frame	Voltage	Base Part Number	Stock	List Price	Eff %	Weight (lbs)
100	1200	444T	575	1LE6322-4BC11-3AA1		17400	95	1452
125	1200	445T	575	1LE6322-4BC21-3AA1		20990	95	1540
150	1200	447T	575	1LE6322-4CC11-3AA1		23050	96	1792
200	1200	449T	575	1LE6322-4CC21-3AA1		27960	96	2123
250	1200	449T	575	1LE6322-4CC31-3AA1		30730	96	2280
300	1200	L449T	575	1LE6322-4DC11-3AA1		41260	96	2830

**SD200 841 | Eff: NEMA Premium | 6 Pole | 575V | Ball Bearing | Short Shaft
Without Winding Protection**

Power HP	Speed RPM	NEMA Frame	Voltage	Base Part Number	Stock	List Price	Eff %	Weight (lbs)
100	1200	444TS	575	1LE6322-4FC11-3AA1		17400	95	1454
125	1200	445TS	575	1LE6322-4FC21-3AA1		20990	95	1494
150	1200	447TS	575	1LE6322-4GC11-3AA1		23050	96	1746
200	1200	449TS	575	1LE6322-4GC21-3AA1		27960	96	2075
250	1200	449TS	575	1LE6322-4GC31-3AA1		30730	96	2235
300	1200	L449TS	575	1LE6322-4HC11-3AA1		41260	96	2797

**SD200 841 | Eff: NEMA Premium | 6 Pole | 575V | Roller Bearing | Long Shaft
Without Winding Protection**

Power HP	Speed RPM	NEMA Frame	Voltage	Base Part Number	Stock	List Price	Eff %	Weight (lbs)
100	1200	R444T	575	1LE6322-4SC11-3AA1		18020	95	1465
125	1200	R445T	575	1LE6322-4SC21-3AA1		21610	95	1552
150	1200	R447T	575	1LE6322-4TC11-3AA1		23670	96	1804
200	1200	R449T	575	1LE6322-4TC21-3AA1		28580	96	2135
250	1200	R449T	575	1LE6322-4TC31-3AA1		31350	96	2292
300	1200	RL449T	575	1LE6322-4UC11-3AA1		41870	96	2855

**SD200 841 | Eff: NEMA Premium | 8 Pole | 575V | Ball Bearing | Long Shaft
Without Winding Protection**

Power HP	Speed RPM	NEMA Frame	Voltage	Base Part Number	Stock	List Price	Eff %	Weight (lbs)
75	900	444T	575	1LE6322-4BD11-3AA1		20240	94	1411
100	900	445T	575	1LE6322-4BD21-3AA1		24810	94	1494
125	900	447T	575	1LE6322-4CD11-3AA1		25480	94	1718
150	900	449T	575	1LE6322-4CD21-3AA1		32580	94	1967
200	900	L449T	575	1LE6322-4DD11-3AA1		47060	95	2579
250	900	L449T	575	1LE6322-4DD21-3AA1		51500	95	2853

**SD200 841 | Eff: NEMA Premium | 8 Pole | 575V | Ball Bearing | Short Shaft
Without Winding Protection**

Power HP	Speed RPM	NEMA Frame	Voltage	Base Part Number	Stock	List Price	Eff %	Weight (lbs)
75	900	444TS	575	1LE6322-4FD11-3AA1		20240	94	1402
100	900	445TS	575	1LE6322-4FD21-3AA1		24810	94	1482
125	900	447TS	575	1LE6322-4GD11-3AA1		25480	94	1280
150	900	449TS	575	1LE6322-4GD21-3AA1		32580	94	1958
200	900	L449TS	575	1LE6322-4HD11-3AA1		47060	95	2506
250	900	L449TS	575	1LE6322-4HD21-3AA1		51500	95	2853

**SD200 841 | Eff: NEMA Premium | 8 Pole | 575V | Roller Bearing | Long Shaft
Without Winding Protection**

Power HP	Speed RPM	NEMA Frame	Voltage	Base Part Number	Stock	List Price	Eff %	Weight (lbs)
75	900	R444T	575	1LE6322-4SD11-3AA1		20870	94	1423
100	900	R445T	575	1LE6322-4SD21-3AA1		25430	94	1505
125	900	R447T	575	1LE6322-4TD11-3AA1		26100	94	1730
150	900	R449T	575	1LE6322-4TD21-3AA1		33200	94	1966
200	900	RL449T	575	1LE6322-4UD11-3AA1		47060	95	2579
250	900	RL449T	575	1LE6322-4UD21-3AA1		51500	95	2583

NEMA Premium is a certification mark of the National Electrical Manufacturer's Association

2.2.2. Definite Purpose Low Voltage NEMA Motors

Introduction

ABB Definite Purpose low voltage NEMA motors are designed and built to operate under harsh environments in the industry, including but not limited to petrochemical, pulp and paper mills and waste-water treatment. DP200 HPS motors have all the quality features of the SD200 with additional key features that are key in the Horizontal Pump Systems motors. A wide selection of options, among them bearing isolator and ceramic bearings on drive end, make these motors suitable almost any requirement. The construction of these motors is backed by its three-year warranty and 5 years when ordered with IEEE841 features.

Performance Specification



		DP200 HPS
HP Range	3600 RPM	450-800 HP
Frame Size		FS 509-5013S
Standard Voltage	460V, 575V	FS 509-5013S
Efficiency	NEMA Premium® (MG1-Table 12-12)	FS 509-5013S
Service Factor	1.15 @ 40°C	FS 509-5013S
Insulation	Non-Hygroscopic	Class H
Temperature Rise	Class B	@ 1.0SF
	Class F	@ 1.15SF
Conduit Box (Oversized)	Oversized	Cast Iron
Fan Cover		Metallic
Cooling Fan	Bi-Directional	Polypropylene
Rotor	Die Cast Aluminum	FS 509-5013S
Ingress Protection	NEMA	IP55
Hazardous Location	Gas	CL 1, Div 2 Gr. A, B, C or D Temp Code T3
	Variable Torque VT 20:1	FS 509-5013S
Inverter Duty	Constant Torque CT 3:1	400-600 HP
	Constant Torque CT 35-60HZ	700-800 HP

Key Features

Bearings	Provisions for Bearing RTDs (RTDs added with option A50)
	Insulated NDE bearing
Vibration detectors	Provisions for vibration detectors on each bearing housing
Space Heaters	Standard 120V Space Heaters with Aux Box

Frame and end shields

Definite purpose motors feature cast iron frame, end shields and an easy to access, diagonally split, oversized terminal box; the terminal box is provided with a neoprene gasket and includes a heavy-duty ground lug and non-wicking clearly and permanently marked leads. These characteristics, its zinc-plated hardware, epoxy paint and stainless-steel nameplate provide exceptional structural integrity and resistant to rust and corrosion and make them suitable for severe duty applications in harsh environments.

Rotor and stator windings

A unique offset rotor bar design provides improved efficiency, while larger bars and end rings reduce resistance for lower rotor losses. Each die cast aluminum rotor assembly is dynamically balanced with half key for extended bearing life and includes a high-strength steel (C4140) shaft for maximum rotor performance.

The stator is manufactured with premium electrical C5 grade steel lamination and copper electrical magnet wire that reduce losses.

Insulation

The proprietary Class H non-hygroscopic insulation system, NEMA Class B temperature rise, provides an extra margin of thermal life. The varnish system application ensures maximum wire penetration to provide protection from moisture, corrosion and electrical shock. This insulation system meets or exceeds NEMA MG1 2014 Part 31 making the motors suitable for variable speed drives in constant torque (3:1, 2:1) and variable torque (20:1). All windings are tested for CIV.

Cooling system

A non-sparking, bi-directional fan is locked and keyed to the shaft. Its low-inertia design reduces windage losses, improves airflow, reduces noise and provides dependable cooling. Metal sheet fan covers are provided for all frame sizes.

Bearings

DP200 HPS motors have 63 series bearings on both ends with Insulated shaft on NDE as standard to help minimize bearing failure due to shaft currents. (INSOCOAT bearing on NDE prior to January 2021).

2.2.2.1. DP200 HPS

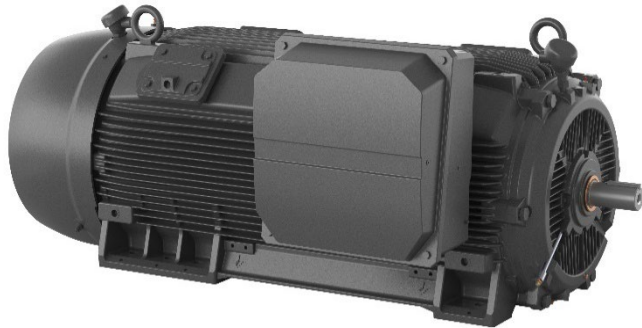

**DP200 HPS | Eff: NEMA Premium | 2 Pole | 460V | Ball Bearing | Short Shaft
Without Winding Protection**

Power HP	Speed RPM	NEMA Frame	Voltage	Base Part Number	Stock	List Price	Eff %	Weight (lbs)
400	3600	509S	460	1PC6521-5EA11-2AA1		57460	96	4219
450	3600	5010S	460	1PC6521-5EA21-2AA1		58590	96	4357
500	3600	5011S	460	1PC6521-5EA81-2AA1	+	58850	96	4504
600	3600	5011S	460	1PC6521-5EA01-2AA1	+	65140	97	4936
700	3600	5013S	460	1PC6521-5FA71-2AA1		75690	97	5538
800	3600	5013S	460	1PC6521-5FA81-2AA1	+	79380	97	5798

**DP200 HPS | Eff: NEMA Premium | 2 Pole | 460V | Ball Bearing | Short Shaft
With Stator RTDs**

Power HP	Speed Rpm	NEMA Frame	Voltage	Base Part Number	Stock	List Price	Eff %	Weight (lbs)
400	3600	509S	460	1PC6521-5EA11-2AK1		64020	96	4219
450	3600	5010S	460	1PC6521-5EA21-2AK1		65150	96	4357
500	3600	5011S	460	1PC6521-5EA81-2AK1	+	65410	96	4504
600	3600	5011S	460	1PC6521-5EA01-2AK1	+	71700	97	4936
700	3600	5013S	460	1PC6521-5FA71-2AK1		82250	97	5538
800	3600	5013S	460	1PC6521-5FA81-2AK1	+	85940	97	5798

*Stator RTD's 100 ohm platinum w aux box-terminal strip 2/phase

NEMA Premium is a certification mark of the National Electrical Manufacturer's Association

**DP200 HPS | Eff: NEMA Premium | 2 Pole | 575V | Ball Bearing | Short Shaft
Without Winding Protection**

Power HP	Speed RPM	NEMA Frame	Voltage	Base Part Number	Stock	List Price	Eff %	Weight (lbs)
400	3600	509S	575	1PC6521-5EA11-3AA1		60740	96	4219
450	3600	5010S	575	1PC6521-5EA21-3AA1		61870	96	4357
500	3600	5011S	575	1PC6521-5EA81-3AA1		62130	96	4504
600	3600	5011S	575	1PC6521-5EA01-3AA1		68420	97	4936
700	3600	5013S	575	1PC6521-5FA71-3AA1		78970	97	5538
800	3600	5013S	575	1PC6521-5FA81-3AA1		82660	97	5798

**DP200 HPS | Eff: NEMA Premium | 2 Pole | 575V | Ball Bearing | Short Shaft
With Stator RTDs**

Power HP	Speed RPM	NEMA Frame	Voltage	Base Part Number	Stock	List Price	Eff %	Weight (lbs)
400	3600	509S	575	1PC6521-5EA11-3AK1		67300	96	4219
450	3600	5010S	575	1PC6521-5EA21-3AK1		68430	96	4357
500	3600	5011S	575	1PC6521-5EA81-3AK1		68690	96	4504
600	3600	5011S	575	1PC6521-5EA01-3AK1		74980	97	4936
700	3600	5013S	575	1PC6521-5FA71-3AK1		85530	97	5538
800	3600	5013S	575	1PC6521-5FA81-3AK1		89220	97	5798

*Stator RTD's 100 ohm platinum w aux box-terminal strip 2/phase
NEMA Premium is a certification mark of the National Electrical Manufacturer's Association

2.3. Option selection and pricing – Introduction



ABB offers a wide selection of options to increase the suitability of our motors to the specific customer needs.

Modified stock options:

Modified – 3-7 days

Special testing – 15-25 days

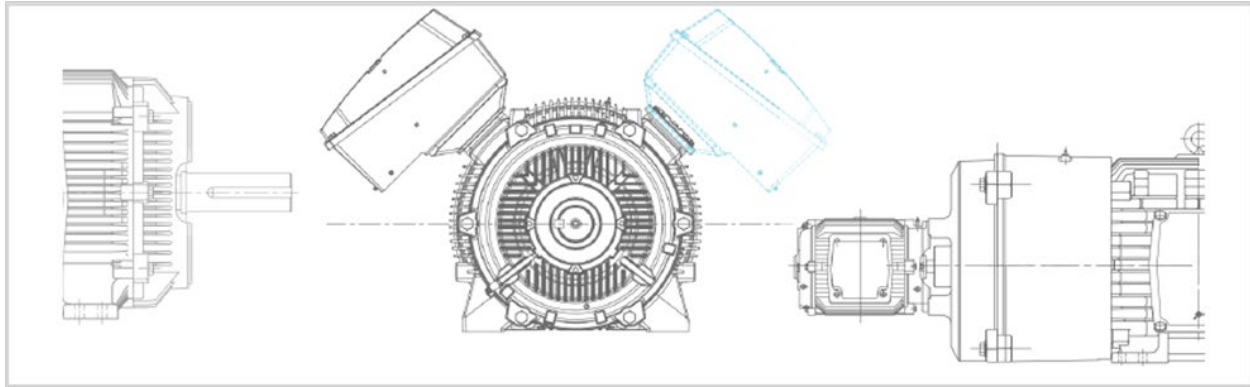
Note: Modification times are dependent on availability of materials.

Custom build options:

Case A-1: Base custom delivery

Case A-2: One additional week

Case B: Three additional weeks

Note: See Weekly Stock List for updated lead times on delivery cases.

Definitions:

MLFB Digit – Modifications or custom features that are built into the motor part number (MLFB).

Short Codes – Modifications or custom features that are added after the part number.

Ordering instructions:

1. Select a stock motor from the **Motor Selection and Pricing Section** (Note Part Number)
2. **Verify applicability of desired Option(s) at the end of the section** (Per motor type and frame)
3. Select applicable Option(s)

4. **Construct new Part Number and List Price** (See example below)

- a) If the MLFB Position is 12, 13, 14, 15 or 16, replace the number(s) or letter(s) at the same position(s) in the stock motor **Part Number** with the **MLFB Code**.
- b) If the option is a **Short Code**, then add a '-Z' to the end of the motor **Part Number** and add the **short code**. Then add a '+' sign followed by the **additional short Code(s)**.

Custom options combined with modification options - Motor Pricing Example:

Example: 150HP, 1800RPM, 460V, 445T, SD200, C-face with feet, PTC thermistors with Aux box on DE in F2 position.

Base List Price	\$18,900	Part Number 1LE63214BB212AA1
List Price Adders		
C-Face with Feet	\$1,300	Order Code N , Order Code Position 14
PTC Thermistors	\$640	Order Code B , Order Code Position 15
Aux Box in F2	\$400	Order Code R01 , Order Code Position Z
Total List Price	\$21,240	New Part Number – 1LE63214BB212NB1-Z R01
Delivery		Case A-1

Option Selection and Pricing

Codes	Description	Case	Modified	440	L449	500	SD200	DP200	HPS Notes
Voltage and Connection									
MLFB DIGIT 12-13	12	460V	STD	STD	0	0	0	•	•
	13	575	STD	STD	0	0	3280	+	+
	22	460V PWS 60HZ	A-1	Mod ¹	750	750	1520	+	+
	23	575V PWS 60HZ	A-1	–	800	800	1520	+	+
	32	WyeStrt-DeltaRun460, 60Hz	A-1	Mod ¹	750	750	1520	+	+
	33	WyeStrt-DeltaRun575, 60Hz	A-1	–	800	800	1520	+	+
	90	(M6Y) Special Winding 200-600V	A-1	–	1200	1200	2930	+	+
Mounting									
MLFB DIGIT 14	A	Foot Mounted Horizontal (IMB3)	STD	STD	0	0	0	•	•
	C	Foot Mounted Vertical Shaft-Down w/o Canopy (IMV5)	A-1	Mod	2100	2100	7440	+	+
	D	Foot Mounted Vertical Shaft-Up (IMV6)	A-1	Mod	2100	2100	7440	+	+
	F	Footless D-flange Horizontal (IMB5)	A-1	–	2140	2140	–	+	–
	G	Footless D-flange Vertical Shaft-down w/o canopy (IMV1)	A-1	–	3900	3900	–	+	–
	H	Footless D-flange Vertical Shaft-up (IMV3)	A-1	–	3900	3900	–	+	–
	J	Foot Mounted D-Flange Horizontal (IMB35)	A-1	–	2140	2140	2140	+	+
	K	Footless C-Face Horizontal (IMB14)	A-1	–	1300	1300	–	+	–
	L	Footless C-Face Vertical Shaft-down w/o canopy (IMV19)	A-1	–	3200	3200	–	+	–
	M	Footless C-Face Vertical Shaft-up (IMV18)	A-1	–	3200	3200	–	+	–
	N	Foot Mounted C-face Horizontal (IMB34 – F1 / F2 / F3)	A-1	Mod	1300	1300	–	+	–
	P	Foot Mounted C-Face Vertical Shaft-down w/o Canopy – W6 / W7 / W12]	A-1	Mod	3200	3200	–	+	–
	Q	Foot Mounted C-Face Vertical Shaft-up – W5 / W8 / W11	A-1	Mod	3200	3200	–	+	–
	R	Foot Mounted D-Flange Vertical Shaft-Down w/o Canopy [W6/W7/W12]	A-1	–	3900	3900	9260	+	+
	S	Foot Mounted D-Flange Vertical Shaft-Up [W5/W8/W11]	A-1	–	3900	3900	9260	+	+
	T	Foot Wall Mount Horizontal (MB6, – W2 / W4)	A-1	Mod	2100	2100	14870	+	–
	U	Foot Wall Mounted Horizontal (IMB7 – W1 / W3)	A-1	Mod	2100	2100	14870	+	+
V	Foot Ceiling Mount Horizontal (IMB8 – C1/ C2 / C3)	A-1	Mod	2100	2100	14870	+	+	

+ Available • Standard – Not Available

1. Modification possible only when stocked with 12 leads

[Delivery Cases/Modified](#)

Codes	Description	Case	Modified	440	L449	500	SD200	DP200	HPS Notes
Winding Protection									
MLFB DIGIT 15	A	Without Winding Protection	A-1	STD	0	0	0	+	+
	B	PTC 3 Embedded (Trip), 1 Per Phase	A-1	-	640	640	640	+	+
	C	PTC 6 Embedded (Alarm & Trip), 1 Per Phase	A-1	-	1280	1280	1280	+	+
	G	Thermostats normally closed, Temp code T3C, 1 per phase	A-1	Mod	550	550	670	+	+
	J	Thermocouples Coil Head (Type J)	A-1	-	1800	1800	3710	+	+
	K	Stator RTD's, 2 Per Phase, with aux box	A-1	-	5000	5000	6560	+	+
	L	Winding Protection - G + K	A-1	Mod ²	5500	5500	7230	+	+
	P	PT1000 Resistance Thermometers, 2 Embedded	A-1	-	1120	1120	1120	+	+
Short Codes	A46	Space Heaters 115V single phase, max temp 160°C	A-1	Mod	610	610	610	+	+
	A47	Space Heaters 230V single phase, max temp 160°C	A-1	Mod	610	610	610	+	+
	A48	Space Heaters 115V/230V Single Phase, Max Temp 160°C	A-1	Mod	610	610	610	+	+
	A90	Control Module for PTC Thermistors	B	-	725	725	725	+	+
	C01	Insulation Vacuum Pressure Impregnation (VPI)	A-2	-	9000	9000	27000	+	+
	C03	Spike resistant wire	A-2	-	500	500	3480	+	+
	C04	Insulation moisture/Powerhouse (extra dip & bake)	A-2	-	800	800	1360	+	+
	C07	Insulation Fungus Protection - No UL	A-1	Mod	280	280	300	+	+
C08	Insulation tropicalization (extra dip & bake + fungus spray)	A-2	-	980	980	1560	+	+	

+ Available • Standard - Not Available

2. Modification possible only when stocked with stator RTDs

[Delivery Cases/Modified](#)

Codes	Description	Case	Modified	440	L449	500	SD200	DP200	HPS Notes
Terminal Boxes and Leads									
MLFB DIGIT 16	0	Top Mounted Terminal Box from RHS -Drive End Side	A-1	STD	300	300	300	+	+
	1	LHS Mount - View from DE - Drive End Side (F1)	A-1	STD	0	0	0	•	•
	2	RHS Mount - View from DE - Drive End Side (F2)	A-1	Mod	300	300	300	+	+
	3	Top Mounted Terminal Box from LHS -Drive End Side	A-1	Mod	300	300	300	+	+
	4	LHS Mount - View from DE – Non-Drive End Side (F1)	A-1	–	–	300	300	+	+
	5	RHS Mount - View from DE - Non-Drive End Side (F2)	A-1	–	–	300	300	+	+
	6	Top Mounted Terminal Box from LHS -Non-Drive End Side	A-1	–	–	300	300	+	+
7	Top Mounted Terminal Box from RHS -Non-Drive End Side	A-1	–	–	300	300	+	+	
Short Codes	J84	Conduit Box Orientation 90° (entry from DE)	A-1	Mod	100	100	270	+	+
	J85	Conduit Box Orientation 180°	A-1	Mod	100	100	270	+	+
	J86	Conduit Box Orientation 270° (entry from ODE)	A-1	Mod	100	100	270	+	+
	K80	BURNDY HYDENT YA type terminals	A-2	Mod	150	150	150	+	+
	K81	Special cable leads, 60” long	A-1	–	500	500	3040	+	+
	K82	Special cable leads, 120” long	A-1	–	900	900	6620	+	+
	K83	Terminal Block in Main Box	A-1	Mod	2800	2800	2800	+	+
	K85	3 Terminal Connection	A-1	–	0	0	0	+	+
	K89	Sealed Leads	A-1	–	740	740	1520	+	+
	T00	Main Terminal Box - at a 45° angle	A-1	Mod	150	150	150	+	+
	T03	Main Terminal Box – Oversized Steel (Centered Cable Entry)	A-1	Mod	1400	1400	–	+	–
	T04	Steel terminal box oversized 20X20X16(in) with blank entry	A-1	–	2880	2880	2880	+	+
	T05	Steel terminal box oversized 28.5X24.4X20(in) with blank entry	A-1	–	–	–	5200	+	+
	T06	Steel terminal box oversized 18.5X22X7.5(in) with blank entry	A-1	–	1200	1200	–	+	–
	T10	Centered Terminal Box	A-1	Mod	400	–	–	+	–
	T11	Centered Retrofit Terminal Box	A-1	Mod	700	–	–	+	–
T50	Dual Entry Hole Terminal Box	A-1	Mod	350	350	350	+	+	
Y96	Non-Standard NPT entry	A-1	–	400	400	400	+	+	

+ Available • Standard – Not Available ** Coming soon

1. Select FS500 motors will be stocked with Stator RTDs
2. Stock Mod only possible when stocked with stator RTDs

Delivery Cases/Modified

Codes	Description	Case	Modified	440	L449	500	SD200	DP200	HPS	Notes
Terminal Boxes and Leads – Aux Boxes										
R00	Cast Iron Aux Box for thermal protection - Position 1 (F1 DE)	A-1	Mod	400	400	600	+	+		Note 1
R01	Cast Iron Aux Box for thermal protection - Position 2 (F2 DE)	A-1	Mod	400	400	600	+	+		Note 1
R02	Cast Iron Aux Box for thermal protection - Position 4 (F1 NDE)	A-1	Mod	400	400	600	+	+		Note 1
R03	Cast Iron Aux Box for thermal protection - Position 5 (F2 NDE)	A-1	Mod	400	400	600	+	+		Note 1
R04	Condulet Box for thermal protection - Position 1 (F1 DE)	A-1	Mod	250	250	400	+	+		
R05	Condulet Box for thermal protection - Position 2 (F2 DE)	A-1	Mod	250	250	400	+	+		
R06	Condulet Box for thermal protection - Position 4 (F1 NDE)	A-1	Mod	250	250	400	+	+		
R07	Condulet Box for thermal protection - Position 5 (F2 NDE)	A-1	Mod	250	250	400	+	+		
R10	Cast Iron Aux Box for space heaters - Position 1 (F1 DE)	A-1	Mod	400	400	600	+	+		
R11	Cast Iron Aux Box for space heaters - Position 2 (F2 DE)	A-1	Mod	400	400	600	+	+		
R12	Cast Iron Aux Box for space heaters - Position 4 (F1 NDE)	A-1	Mod	400	400	600	+	+		
R13	Cast Iron Aux Box for space heaters - Position 5 (F2 NDE)	A-1	Mod	400	400	600	+	+		
R14	Condulet Box for space heaters - Position 1 (F1 DE)	A-1	Mod	250	250	400	+	+		
R15	Condulet Box for space heaters - Position 2 (F2 DE)	A-1	Mod	250	250	400	+	+		
R16	Condulet Box for space heaters - Position 4 (F1 NDE)	A-1	Mod	250	250	400	+	+		
R17	Condulet Box for space heaters - Position 5 (F2 NDE)	A-1	Mod	250	250	400	+	+		
R20	Cast Iron Aux Box for all accessories - Position 1 (F1 DE)	A-1	Mod	400	400	600	+	+		Note 1
R21	Cast Iron Aux Box for all accessories - Position 2 (F2 DE)	A-1	Mod	400	400	600	+	+		Note 1
R22	Cast Iron Aux Box for all accessories - Position 4 (F1 NDE)	A-1	Mod	400	400	600	+	+		Note 1
R23	Cast Iron Aux Box for all accessories - Position 5 (F2 NDE)	A-1	Mod	400	400	600	+	+		Note 1
R24	Condulet Box for all accessories - Position 1 (F1 DE)	A-1	Mod	250	250	400	+	+		
R25	Condulet Box for all accessories - Position 2 (F2 DE)	A-1	Mod	250	250	400	+	+		
R26	Condulet Box for all accessories - Position 4 (F1 NDE)	A-1	Mod	250	250	400	+	+		
R27	Condulet Box for all accessories - Position 5 (F2 NDE)	A-1	Mod	250	250	400	+	+		

Short Options

+ Available • Standard – Not Available

Note 1 – No cost when used with stator RTDs

Delivery Cases/Modified

Codes	Description	Case	Modified	440	L449	500	SD200	DP200	HPS	Notes
Bearings and Lubrication										
Short Options	A50	Install Bearing RTD's-100 Ohm Platinum -Both Ends & Terminal Heads/Block	A-1	Mod	-	-	3070	-	+	
	A51	Bearing RTD's-100 Ohm Platinum -Both Ends & Terminal Heads/Block	A-2	-	3350	3350	3390	+	-	
	L49	Automatic Grease Relief Fitting	A-1	Mod	150	150	**	+	+	
	L50	Bearing Insulation for DE	A-1	-	750	750	**	+	+	
	L51	Bearing Insulation for NDE	A-1	-	750	750	**	+	•	
	L54	Provisions for oil mist (within 6 months)	A-2	-	4200	4200	-	+	-	
	L55	Oil Mist Ready (must use oil mist)	A-2	-	4200	4200	-	+	-	
	L57	MOBIL 28- High or Low - Special Grease	A-2	Mod	1500	1500	1650	+	+	
	L58	MOBILITH SHC 100 -Special Grease	A-2	Mod	650	650	850	+	+	
	L61	Insulated Bearing -INSOCOAT (Both Ends)	A-1	Mod	8000	8000	8000	+	+	Not for Roller Bearing
	L62	Insulated Bearing -INSOCOAT (DE Only)	A-1	Mod	4000	4000	-	+	-	Not for Roller Bearing
	L64	Insulated Bearing -INSOCOAT (NDE Only)	A-1	Mod	4200	4200	4200	+	+	
	L68	Sealed Ball Bearings (Both Ends)	A-1	Mod	1000	1000	-	+	-	No 2 pole, Not for Roller Bearing
	L69	Hybrid (Ceramic Ball) Bearings - Both Ends	B	Mod	12000	12000	19730	+	+	Not for Roller Bearing
	L70	Hybrid (Ceramic Ball) Bearings - NDE	B	Mod	6000	6000	9870	+	+	
L71	Hybrid (Ceramic Ball) Bearings - DE	B	Mod	7000	7000	9870	+	+	Not for Roller Bearing	
Shafts and Seals										
Short Options	K41	Keyless shaft	A-1	-	100	100	420	+	+	
	K42	Retrofit S449 Shaft Extension	A-1	-	-	630	-	+	-	
	L29	Shaft Grounding Brush	A-2	Mod	3800	3800	3800	+	+	Removes Division 2
	L76	Shaft Slinger & O Ring	A-1	Mod	200	200	-	+	-	
	L79	INPRO/SEAL DE	A-1	Mod	1000	1000	1150	+	+	
	L80	INPRO/SEAL ODE	A-2	Mod	1000	1000	1150	+	+	
	L81	INPRO/SEAL - Both Ends	A-2	Mod	2000	2000	2300	+	+	
	L89	INPRO/SEAL MGS shaft grounding - DE	A-1	Mod	2490	2490	3320	+	+	
	M52	NEMA std long shaft - ODE	A-2	-	550	550	-	+	-	
	M53	NEMS std short shaft - ODE	A-2	-	550	550	-	+	-	
	M57	(C4140) Carbon steel shaft	A-2	-	1800	1800	2230	+	+	
Y50	Special shaft on Drive End	B	-	800	800	CF	+	+		
Y51	Special shaft on Non-Drive End	B	-	800	800	CF	+	+		

+ Available • Standard - Not Available CF Consult Factory

Delivery Cases/Modified

Codes	Description	Case	Modified	440	L449	500	SD200	DP200	HPS Notes	
Frame										
Short Options	K33	Drip Cover	A-1	Mod	400	400	2970	+	+	
	K38	Provisions for Dowel Holes	A-1	Mod	900	900	•	+	+	
	K70	Rotation Arrow Bi-directional	A-1	Mod	150	150	150	+	+	
	K71	Rotation Arrow Clockwise (From NDE)	A-1	Mod	150	150	150	+	+	
	K72	Rotation Arrow Counterclockwise (From NDE)	A-1	Mod	150	150	150	+	+	
	L22	Stainless Steel Hardware (Includes T Drain SS)	A-1	Mod	600	600	650	+	+	
	L27	Ground Bolts - Qty 2	A-1	Mod	150	150	150	+	+	
	L45	SS T - Slot Breather Drain	A-1	Mod	300	300	300	+	+	
	L46	CROUSE HINDS UL Approved Breather Drain	A-1	Mod	350	350	380	+	+	
	L91	IP56 Ingress Protection	A-1	-	500	500	-	+	-	
	M10	Bronze Fan	A-1	-	3500	3500	-	+	-	
M39	Vertical Jacking Provisions	A-1	Mod ¹	550	550	1200	+	+		
Rating Plates and Tagging										
C40	Rerate 50HZ Voltage to 380V	A-1	Mod	170	-	-	+	-		
C41	Rerate 50HZ Voltage to 415V	A-1	Mod	170	-	-	+	-		
M21	Additional nameplate (without logos)	A-1	-	200	200	200	+	+		
M25	Class II, Division 2	A-1	Mod	STD	STD	1350	+	+		
Y80	Derate-Alt-Amb (Nameplate Change)	A-1	Mod	170	170	170	+	+		
Y82	Auxiliary n/p Max. 40 Characters (Aux Tag)	A-1	Mod	100	100	100	+	+		
Ambient Temperature										
Short Options	B27	+40°C to-30°C Ambient temp	A-2	-	1450	1450	4200	+	+	
	B28	+40°C to-40°C Ambient temp	B	-	1600	1600	4200	+	+	
	B29	+40°C to-50°C Ambient temp	B	-	2200	2200	4500	+	+	
Mechanical Design and Accessories										
Short Options	A67	Provision only for vibration sensors	A-1	-	500	500	500	+	-	
	A68	Metrix Sensors Installed on DE and NDE, top of the end shield	B	-	14000	14000	14000	+	+	
	G05	Dynapar Encoder HS35R 1024 PPR	B	-	1900	1900	2500	+	+	
	G06	C-Face Mounted Slim Tach Encoder	B	-	4750	4750	4750	+	+	
	K10	IEEE 841 Features	B	-	-	-	960	-	+	
	M08	Separately Driven Fan for 1000:1 CT - VFD Only Operation	A-1	Mod	3400	3400	3400	+	+	
	M69	Precision Balance	A-1	-	340	340	-	+	-	Standard for 841
	M70	Extra Precision Balance	A-1	-	620	620	-	+	-	

+ Available • Standard - Not Available

** Coming soon

Delivery Cases/Modified

Codes	Description	Case	Modified	440	L449	500	SD200	DP200	HPS Notes
Paint and Packaging									
B07	Special Stackable Packing	A-1	-	800	-	-	+	-	
B09	Export Packaging Sea Freight – ABB Standard	A-1	Mod	1010	1010	2430	+	+	
B11	Export Packaging Sea freight – ABB Standard + sensors	A-1	-	1050	1050	-	+	+	
N01	2 Part Epoxy (Industrial-Coastal low salt)	B	-	1400	1400	3210	+	+	
N02	3 Part Epoxy (Industrial-Coastal moderate salt)	B	-	3950	3950	3450	+	+	
N03	Primer only	A-1	-	550	550	550	+	+	
N05	3 Part Epoxy (Coastal-offshore high salt)	B	-	4600	4600	7120	+	+	
N06	2 Part Epoxy C4 (Industrial-Coastal moderate salt)	A-2	-	1520	1650	3105	+	+	
N07	2 Part Epoxy C5I/C5M (Coastal-offshore high salt)	A-2	-	2050	2255	4985	+	+	
Y60	Special color for standard paint system (Provide RAL#)	A-1	-	200	200	200	+	+	
Y61	Special color for special paint system (Provide RAL#)	A-1	-	100	100	100	+	+	Must include N01, N02, N05, N06, or N07
Documentation									
D05	Documentation in Spanish	A-1	--	0	0	0	+	+	
F00	Certificate of Compliance	A-1	Mod	300	300	300	+	+	
F01	Certificate of Origin - Stamped by Chamber of Commerce	A-1	Mod	900	900	900	+	+	
F03	Standard Performance Curves	A-1	Mod	450	450	450	+	+	
F04	Acceleration Time Calculation	A-1	Mod	190	190	190	+	+	
F05	Polarization Index	A-1	--	150	150	150	+	+	
F07	Curve Package at 100% and 80% voltage (S-T, PERF)	A-1	Mod	750	750	750	+	+	
F08	Shaft Torsional Analysis (includes shaft drawing)	A-1	Mod	500	500	500	+	+	
F09	Bearing L10 Calculation	A-1	Mod	550	550	550	+	+	
F40	Stall Time Curve (Thermal Limit Curve)	A-1	Mod	310	310	310	+	+	
F42	Standard Dimensional Sheet	A-1	Mod	150	150	150	+	+	
F43	Non-Standard Dimension Sheet	A-2	Mod	550	550	550	+	+	
F44	Conduit Box Dimension Sheet	A-1	Mod	310	310	310	+	+	
F45	Wiring Diagram	A-1	Mod	150	150	150	+	+	
F46	Instruction & Operation Manual in English	A-1	Mod	150	150	150	+	+	
F47	Renewal Parts	A-1	Mod	150	150	150	+	+	
F48	CAD Drawing (Dwg Format) Customer/Application Specific	A-1	Mod	610	610	610	+	+	
F49	Performance Data Sheets	A-1	Mod	260	260	260	+	+	
F50	Customer Specific Data Sheets	A-2	Mod	550	550	550	+	+	

Short Options

Codes	Description	Case	Modified	440	L449	500	SD200	DP200	HPS Notes
F51	Shaft Profile Detail (included materials data)	A-1	Mod	200	200	200	+	+	
F60	Visual Inspection Proof (Max 8X Photos)	A-1	Mod	340	340	340	+	+	
F70	Inspection Test Plan	A-1	--	500	500	500	+	+	
F71	Paint Report (thickness and adherence)	A-1	--	150	150	150	+	+	
F81	Advanced Document Package	A-1	--	1650	1650	1650	+	+	
F82	Project Document Package	A-2	--	3000	3000	3000	+	+	
Tests									
F10	Routine Test Report	A-1	Mod	250	250	250	+	+	
F12	Routine Test Report (Witnessed)	A-2	Mod	2750	2750	3470	+	+	
F15	Complete Test	A-1	Mod	12050	12050	**	+	+	
F17	Complete Test (Witnessed)	A-2	Mod	18050	18050	**	+	+	
Short Options	F20	Routine Test + Vibration	A-1	Mod	600	600	600	+	+
	F22	Routine Test + Vibration (Witnessed)	A-2	Mod	3250	3250	3780	+	+
	F27	Performance Load Test (Curve Report)	A-1	Mod	7210	7210	7210	+	+
	F30	Noise test	A-1	-	3870	3870	3870	+	+
	F32	Noise test (Witnessed)	A-2	-	7865	7865	7865	+	+
	F36	Routine Test Report of Electrical Duplicate Design	A-1	Mod	250	250	250	+	+
	F37	Type Test Report of Electrical Duplicate Design	A-1	Mod	455	455	455	+	+

+ Available • Standard - Not Available
 Delivery Cases/Modified

3. Low Voltage NEMA Motors

Technical details, options, motor selection, and pricing

GP100A, GP100, SD100, SD100 IEEE841, SD661, LP100, HP100, XP100, XP100 ID1

- 3.1. Technical Details 75**
 - 3.1.1. MLFB Structure 75
 - 3.1.2. Technical Information 76
 - 3.1.2.1. Voltage and Connection 76
 - 3.1.2.2. Mounting 78
 - 3.1.2.3. Winding Protection 79
 - 3.1.2.4. Terminal Boxes and Leads 83
 - 3.1.2.5. Bearings and Lubrication 86
 - 3.1.2.6. Shafts and Seals 91
 - 3.1.2.7. Frame 93
 - 3.1.2.8. Rating Plates and Tagging 96
 - 3.1.2.9. Ambient and Altitude 99
 - 3.1.2.10. Mechanical Design & Accessories 100
 - 3.1.2.11. Paint and Packaging 102
 - 3.1.2.12. Documentation 104
 - 3.1.2.13. Tests 107
- 3.2. Motor Selection and Pricing 109**
 - 3.2.1. General Purpose Low Voltage NEMA Motors 109
 - 3.2.1.1. GP100A 111
 - 3.2.1.2. GP100 113
 - 3.2.2. Severe Duty Low Voltage NEMA Motors 121
 - 3.2.2.1. SD100 123
 - 3.2.2.2. SD100 Low Maintenance 131
 - 3.2.2.3. SD100 IEEE841 133
 - 3.2.2.4. SD661 142
 - 3.2.3. Explosion Proof Low Voltage NEMA Motors 143
 - 3.2.3.1. XP100 145
 - 3.2.3.2. XP100 ID1 152
 - 3.2.3.3. XP100 JP Frame 156
 - 3.2.4. Definite Purpose Low Voltage NEMA Motors 157
 - 3.2.4.1. Vertical Solid Shaft – LP100 159
 - 3.2.4.2. Vertical Solid Shaft – HP100 163
 - 3.2.4.3. Two Speed Motors – SD10MS 167
- 3.3. 170**
- 3.4. Option Selection and Pricing – Introduction 170**
 - 3.4.1. Option Selection and Pricing 172

3.1. Technical details

3.1.1. MLFB Structure

MLFB Structure	1	2	3	4	5	6	7	-	8	9	10	11	12	-	13	14	15	16	-Z
Motor Series	1	2	3						-						-				
Standard GP, SD Motors	1	L	E						-						-				
Division 1 Explosion Proof Motors	1	M	B						-						-				
Definite Purpose Motors	1	P	C																
Main Series				4					-						-				
NEMA Motors				2					-						-				
Motor Type/Enclosure/ Efficiency					5	6	7		-						-				
GP100A NP	1	L	E	2	1	2	1		-						-				
GP100 NP	1	L	E	2	2	2	1		-						-				
SD100 NP	1	L	E	2	3	2	1		-						-				
SD100 NP (Low Maintenance)	1	L	E	2	3	2	3		-						-				
SD100 IEEE841 NP	1	L	E	2	4	2	1		-						-				
SD661	1	L	E	2	4	2	2		-						-				
SD10 MS	1	L	E	2	3	0	1		-						-				
XP100	1	M	B	2	1	2	1		-						-				
XP100 ID1	1	M	B	2	2	2	1		-						-				
HP100	1	P	C	2	8	2	2		-						-				
LP100	1	P	C	2	8	3	2		-						-				
Motor HP and Frame									-	8	9		11		-				
Number of Poles (Speed)									-			10			-				
2 Pole (3000/3600 RPM)									-			A			-				
4 Pole (1500/1800 RPM)									-			B			-				
6 Pole (1000/1200 RPM)									-			C			-				
8 Pole (750/900 RPM)									-			D			-				
8/4 Pole (Two Speed)									-			M			-				
Winding Design/Voltage/Frequency									-					12	-	13			
Mounting									-							-	14		
Winding Protection									-							-		15	
Terminal Box Position									-							-			16
With Additional Options									-							-			-Z

3.1.2. Technical Information

3.1.2.1. Voltage and Connection

		140-250 Frames	280-400 Frames	440-S449 Frames
MLFB DIGITS 12 & 13	11 230V	3 Lead Wye Fig. 2.1	3 Lead Delta Fig. 2.2	N/A
	12 460V	3 Lead Wye Fig. 2.1	3 Lead Delta Fig. 2.2	3 Lead Delta Fig. 2.2 or Fig. 2.3
	13 575V	3 Lead Wye Fig. 2.1	3 Lead Delta Fig. 2.2	3 Lead Delta Fig. 2.2 or Fig. 2.3
	14 230/460 (Suitable for 208V)	9 Lead Wye Fig. 2.4	N/A	N/A
	16 230/460	9 Lead Wye Fig. 2.4	9 Lead Delta Fig. 2.5	N/A
	22 PWS 460V 60Hz	–	Part Winding Start Fig. 2.6	
	23 PWS 575V 60HZ	–	Part Winding Start Fig. 2.6	
	32 Y/D 460V 60Hz	–	6 Lead Wye-Start Delta-Run Fig. 2.7	
	33 Y/D 575V 60HZ	–	6 Lead Wye-Start Delta-Run Fig. 2.7	
	40 460V Y, YY, 60HZ, 1 Winding Variable Torque		2 Speed - 1 Winding VT Fig. 2.8	
	44 575V Y, YY, 60HZ, 1 Winding Variable Torque		2 Speed - 1 Winding VT Fig. 2.8	
	90 M2Y (200-600V)		As Specified	

Pricing

Voltage

Low voltage NEMA motors can operate from 200-600V according to the winding selection. Windings up to 230V can only be applied to motors with 75HP or less.

Part-Winding-Start and Wye-Start/ Delta-Run are special windings that help to limit the amount of inrush current at startup. Both options require a special motor starter to operate correctly.

Special voltage, **M2Y**, can be used for any voltage within the voltage range listed for each.

When used for 50HZ operation the service factor will be 1.0 with the standard HP output. Electrical Data must be calculated and provided by the factory when **M2Y** is selected. For 50HZ operation at 1.15 S.F. de-rate to the next smaller HP can be requested with option **Y80** (see [Rating Plates and Tagging section](#)).

Low voltage NEMA motors are designed with the following tolerances in accordance with NEMA MG-1:

- Voltage tolerance: +/-10% of rated voltage
- Frequency tolerance: +/- 5% of rated frequency
- Voltage & Frequency combined tolerance: +/-10% (sum of absolute values)

Winding connection:

140-250 frame: Y for single voltage and YY/Y for dual voltage

280 frame and up: Δ for single voltage and Δ Δ / Δ for dual voltage

440T frames with 3 lead connection may have paired leads for flexibility in connection. Figure 2.3

See [Terminal Box and Leads section](#) for additional information on motor leads.

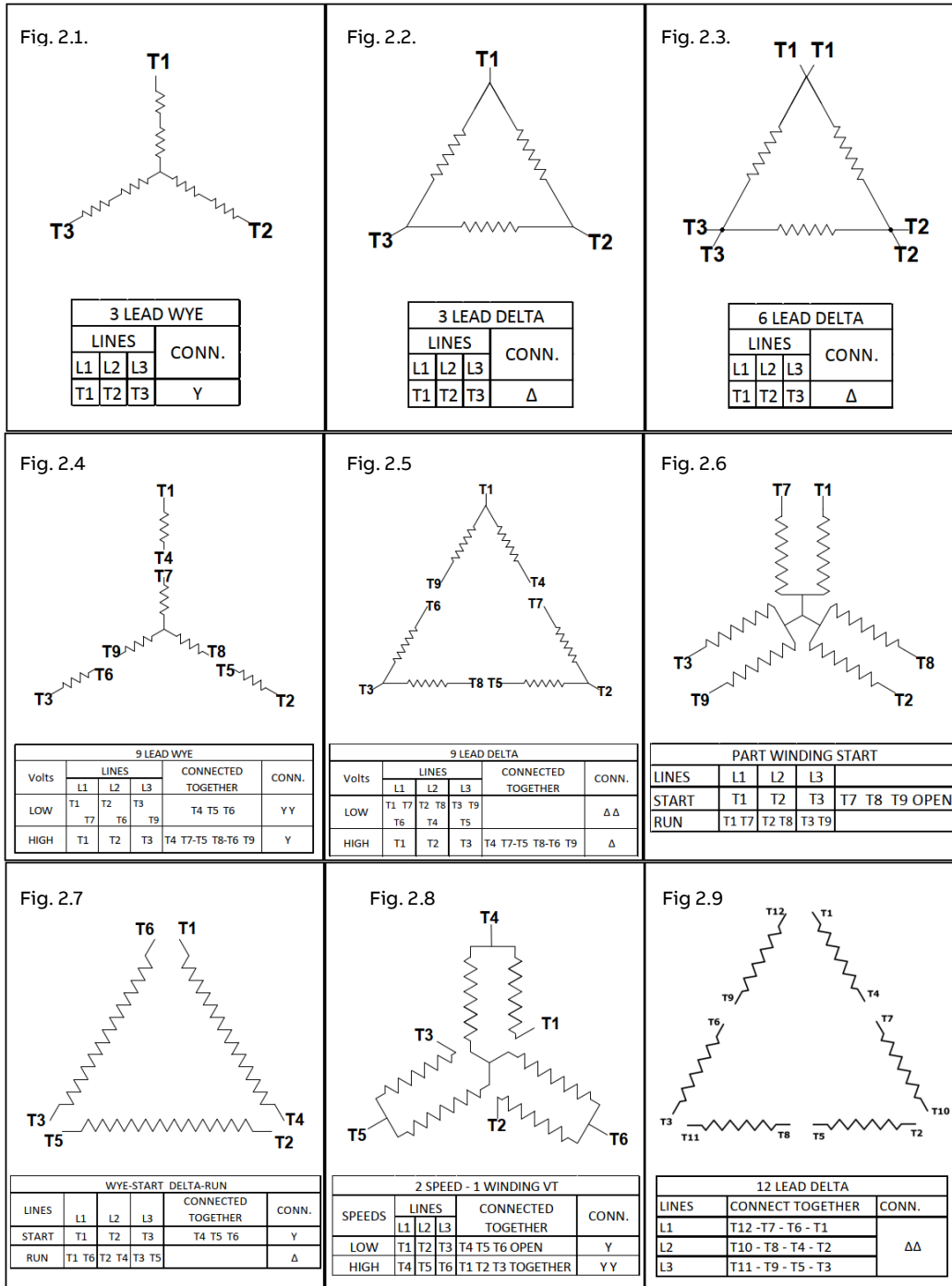

3.1.2.2. Mounting

Codes	Description	1LE2	1MB2	1PC2
A	Foot Mount	+	+	-
E	C - Face with Feet	+	+	-
F	D - Flange with Feet	+	+	-
G	C - Face without Feet	+	+	-
H	D - Flange without Feet	+	+	-
L	C - Face without Feet with Drip Cover and Lifting Hooks	+	+	-
M	D - Flange without Feet with Drip Cover and Lifting Hooks	+	+	-
N	C - Face with Feet with Drip Cover	+	+	-
P	D - Flange with Feet with Drip Cover	+	+	-
T	P-Base without Feet with Drip Cover and Lifting Hooks	-	-	+
V	CH - Flange w Feet with Drip Cover	-	+	-
W	CH - Flange with Feet	-	+	-
X	CH - Flange without Feet	-	+	-
Y	CH - Flange without Feet with Drip Cover and Lifting Hooks	-	+	-

MLFB DIGIT 14

+ Available • Standard - Not Available Pricing

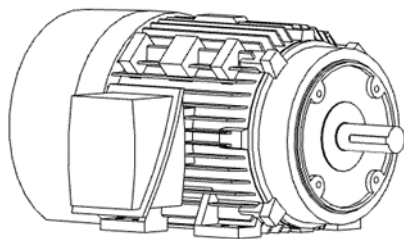

C-Face Foot Mount

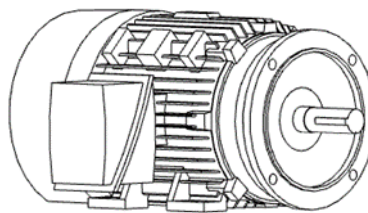

D-Flange Foot Mount

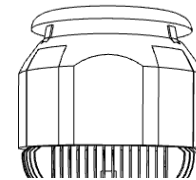

Vertical with Drip Cover

Flange mounting

The drive end bearing housing can be replaced with flange mounting for direct coupling to the driven equipment. Flanges can be supplied with or without feet and as vertical or horizontal as required by the application. S449 frame must use the motor feet as support with flange mounting in either vertical or horizontal mounting positions.

C-Face

The NEMA C-face has threaded holes in the flange and the mounting hardware will be introduced from the driven equipment side. The C-face can be added to a stock motor as a modification where applicable.

CH flange is a standard C-face design in the next smaller size. The CH flange is only available for XP motors in frame size 180.

D-Flange

The NEMA D-flange will have through holes that are unthreaded. The D-flange can be added to stock motors 140-250 frame as a modification where applicable and can be built as custom on all frames. **Note: D-flange is not available on XP motors in frames 140-250.**

Notes:

- D-flange modification on frames 280-449 will result in non-standard usable shaft length when modified from stock
- D-flange is not available on XP motors in frames 140-250
- Round frame motors are only stocked in frames 140-250 and can be custom built up to 449 frames.

3.1.2.3. Winding Protection

Codes	Description	1LE2	1MB2	1PC2
MLFB DIGIT 15	A No Protection	+	+	+
	B PTC 3 Embedded, 1 Per Phase	+	+	+
	C PTC 6 Embedded, 2 Per Phase	+	+	+
	G Thermostats Normally Closed, Temp Code T3C, 1 Per Phase	+	+	+
	J Thermocouples Coil Head	+	+	+
	K Stator RTD's 100-Ohm Platinum w Aux Box-Terminal Strip 2/Phase	+	+	+
	L Winding Protection - G + K	+	+	+
	P PT1000, 2 Embedded Temperature Sensors	+	+	+
	T Thermostats Normally Closed, Temp Code T3, 1 Per Phase (55C Ambient, 1.15SF)	-	+	-
Short Options	A46 Space Heaters 115V Single Phase, Max Temp 160°C	+	+	+
	A47 Space Heaters 230V Single Phase, Max Temp 160°C	+	+	+
	A48 Space Heaters 115/230V Single Phase, Max Temp 160°C	+	+	+
	A90 Control Module	+	+	+
	C00 Insulation Class H	+	+	+
	C01 Insulation Vacuum Pressure Impregnation (VPI)	+	+	+
	C03 Spike Resistant Wire	+	+	+
	C04 Insulation Moisture/Powerhouse (Extra Dip & Bake)	+	+	+
	C07 Insulation Fungus Protection - No UL	+	-	+
C08 Insulation Tropicalization (Extra Dip & Bake + Fungus Spray) – No UL	+	-	+	

+ Available • Standard - Not Available Pricing

Winding insulation

Low voltage NEMA motor stators are random wound and insulated with Class F insulation system which is compliant with NEMA MG-1 part 31 and is rated for 155°C. Spike resistant wire, **C03**, can be used to meet those more stringent specifications that require part 31 to be exceeded. The stator is protected from moisture with acrylic impregnation through a dip and bake process. The stator is designed to have a temp rise no greater than class B at nameplate horsepower.

Class H insulation, **C00**, is rated for 180°C and may be used to better protect the stator when the temp rise may be higher due to ambient conditions or harsher VFD applications. With Class H insulation the lead material will remain Class F.

Moisture Powerhouse (extra dip and bake), **C04**, adds an extra layer of varnish to the winding for added protection against moisture. Vacuum Pressure Impregnation (VPI), **C01**, is an alternative to the standard dip and bake process. VPI uses a vacuum system to pull the varnish into the winding to reduce air bubbles in the varnish. Fungus Protection, **C07, C08**, is an anti-fungal spray that is applied to the windings after the dip and bake process to help reduce fungus from growing on the windings during storage prior to operation.

Space heaters

Space heaters help to reduce the humidity inside the motor during idle times of operation and storage. ABB uses flexible silicone rubber space heaters that have been proven to provide long life which either meets or exceeds the overall life of ABB NEMA motors. Space heaters will have wattage corresponding to the voltage and motor size as seen in Table 4.2 and will have leads to the main box as standard or an aux box as an option with leads marked per Figure 4.1.

ABB offers low temp space heaters rated for a max surface temperature of 160°C for use in safe area, Division 2, or Division 1 certified motors. The heaters can be configured for operation on 115V supply, **A46**, 230V supply, **A47**, or dual rated for 115/230V supply, **A48** (280 frame and up only).

Space heater information plate will be included when space heaters are added to the motor.

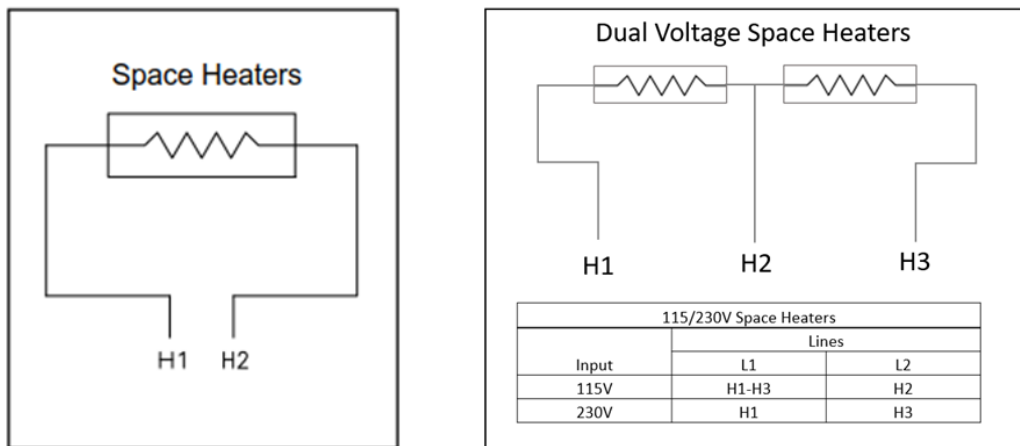

Figure 4.1.

PTC (positive temperature coefficient) thermistors, **MLFB Position 15 “B or C”**, are resistive devices that increase in resistance as the temperature increases. They are set to jump to a very high resistance at a rated temperature. Options are available to have one per phase for trip only, “B”, or two per phase for alarm and trip, “C”. PTC thermistors will have leads to the main box as standard or an aux box as an option with leads marked per Figure 4.3 and Figure 4.4.

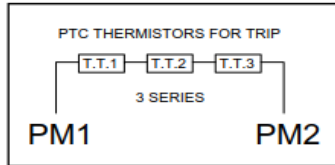

Fig. 4.3

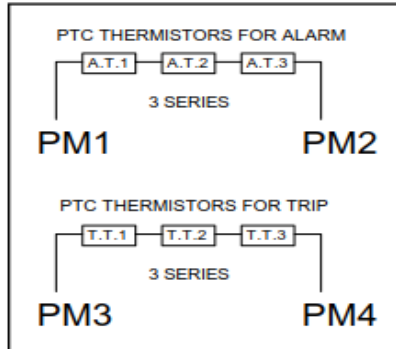

Fig. 4.4

Stator RTDs, **MLFB Position 15 “K”**, are PT100 resistive thermal devices that can be used to monitor the temperature of the motor based on the measured resistance of the device. The resistance range will be 100 ohms at 0 degrees C and increase at a rate of .385 ohms per degree C. RTDs are supplied with two sets per phase (one set active and one set as spares) embedded in the DE end turn of the winding. This option also includes an aux box with a terminal strip with terminals marked per Figure 4.5.

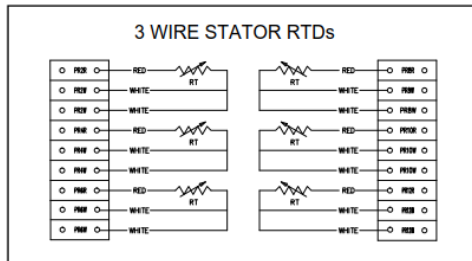

Fig. 4.5

PT1000 sensors, **MLFB Position 15 “P”**, function like the PT100 stator RTDs. The resistance range for the PT1000 sensors is 1000 ohms at 0 degrees C and increases at a rate of 3.85 ohms per degree C. This option comes with two independent sensors (one active and one spare) embedded in the DE end turn of the winding. PT1000 sensors will have leads to the main box as standard or an aux box as an option with leads marked per Figure 4.6.

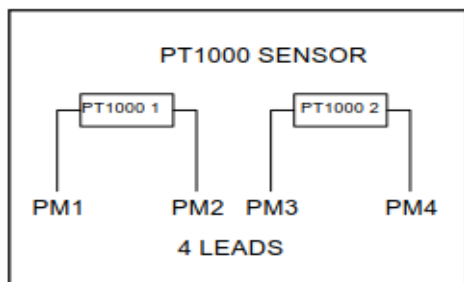

Fig. 4.6

3.1.2.4. Terminal Boxes and Leads

	Codes	Description	1LE2	1MB2	1PC2
MLFB DIGIT 16	0	F-3 Top Mounted Box (GP100A only)	+	-	-
	1	C-2 Ceiling	+	+	-
	2	F-2	+	+	-
	3	F-1	+	+	+
	4	W-6 Shaft Down	+	+	-
	5	W-7 (F-2) Shaft Down	+	+	-
	6	W-5 (F-2) Shaft Up	+	+	-
	7	W-8 Shaft Up	+	+	-
	8	C-1 (F-2) Ceiling	+	+	-
	9-R1A	W-1 (F-2) Wall	+	+	-
	9-R2A	W-2 Wall	+	+	-
	9-R3A	W-3 Wall	+	+	-
	9-R4A	W-4 (F-2) Wall	+	+	-
	Short Codes	Jx0	Separate Condulet on Main Box Side	+	-
Jx2		Condulet to Main Box	+	-	+
Jx3		Aux Box to Main Box	+	-	+
Jx4		Condulet Opposite to Main box Side	+	-	+
Jx5		Aux Box Opposite to Main box Side	+	-	+
Jx6		Explosion Proof Condulet Opposite to Main box Side	-	+	-
Jx7		Explosion Proof Condulet to NDE side of Main Box	-	+	-
J84		Conduit Box Orientation 90° CCW (Entry from DE)	+	+	+
J85		Conduit Box Orientation 180° CCW (Entry from Top)	+	+	+
J86		Conduit Box Orientation 270° CCW (Entry from NDE)	+	+	+
K80		BURNDY HYDENT YA Type Terminals	+	+	+
K83		Terminal Block - 3 Lead Only	+	-	+
K89		Sealed Leads	+	•	+
L01		Cast Iron in Lieu of Aluminum	+	•	•
T04		Steel terminal box - oversized 20X20X16(in) with blank entry	+	-	-
Y85	Special Cable Length (up to 120")	+	-	+	

+ Available • Standard - Not Available Pricing

Main terminal boxes

The main conduit box is diagonally split with a single entrance hole (see drawing section for standard entry hole size) with internal grounding lug provided as standard. The standard terminal box will have a volume that is greater than required by NEMA/NEC.

Terminal Box Material

Motor Type	Frame	Material
GP, GPA	140-250	Aluminum
GP	280-400	Stamped Steel
GP	440	Cast Iron
SD, XP, Definite purpose	All	Cast Iron

Table 5.1

Cast iron terminal box is available as an option, **L01**, on general purpose motors that are supplied with stamped steel box as standard. Explosion proof motors have special round style, cast iron explosion proof terminal box with a rabbet fit cover. Severe Duty motors will be supplied with a gasket between conduit box and frame and between cover and base. Oversized steel box, **T04**, is available with the blank entry. See [Drawings and Dimensions section](#) for additional details.

The main terminal box position is defined by the 16th position of the MLFB. Foot mounted Cast iron frame motor in 1LE2, 1MB2, 1PC2 can have the terminal box located on the left or right of the frame only (Reference Figure 5.1). GP100A motors have the option for top mounted terminal box. The connection entry will be facing the motor feet as standard and can be rotated in 90-degree increments in the field or by ordering with options **J84, J85, J86**. Round Frame motors (without feet) will have the terminal box positioned in relation to the motor condensation drains (drains will be in the lowest position). Auxiliary boxes will be rotated in the same direction as the main box.

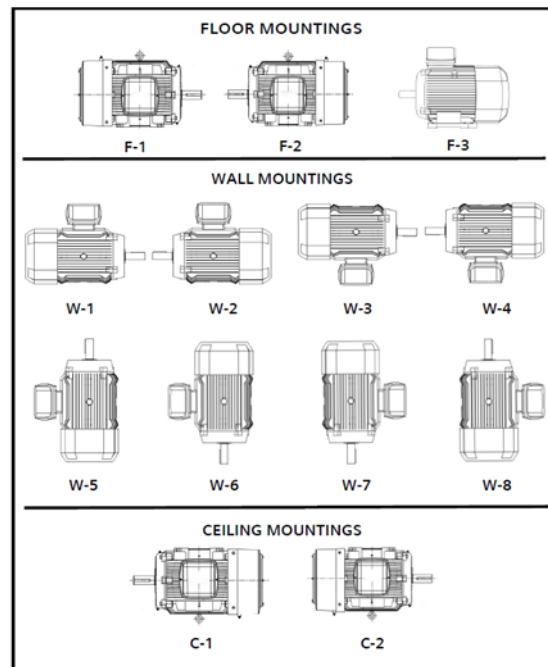

Fig. 5.1

Auxiliary terminal boxes

Auxiliary terminal boxes are available for accessories included in the motor selection. The auxiliary box can be attached to the motor frame or to the side of the main terminal box. Aux box, **Jx3, Jx5**, will be a cast iron auxiliary box. Condulet, **Jx0, Jx2, Jx4** is an aluminum electrical condulet with a steel cover. The explosion proof condulet, **Jx6, Jx7** is a UL approved explosion proof box that has a fully threaded cover.

Jx0 will be on opposing end to main box for frame size S449. The auxiliary box option should be selected according to the accessory that it will be paired with. Stator RTDs will come with an aux box with a terminal strip included as standard. The aux box will be on the opposite to main for the 1LE2, 1MB2, and 1PC2 motors. Bearing RTDs, **A51**, does not require an auxiliary terminal box, as it comes standard with terminal heads on each bearing housing (S449 will have a single auxiliary box).

	PTC Thermistors	Thermostats	PT1000 Sensors	Space Heaters
Condulet on Frame (Same Side as Main)	J00	J10	J20	J50
Condulet on Main Boxes (NDE Side)	J02	J12	J22	J52
Auxiliary Box on Main Box (NDE Side)	J03	J13	J23	J53
Condulet on Frame (Opposite to Main)	J04	J14	J24	J54
Auxiliary Box on Frame (Opposite to Main)	J05	J15	J25	J55
Explosion Proof Condulet on Frame (Opposite to Main)	J06	J16	J26	J56
Explosion Proof Condulet on Main Box	J07	J17	J27	J57

The diagram illustrates seven different motor configurations for auxiliary terminal boxes, labeled Jx0 through Jx8. Each motor is shown from a front-three-quarter perspective. Jx0, Jx2, Jx3, and Jx4 are arranged in the top row, while Jx5, Jx6, and Jx8 are in the bottom row. The configurations show the placement of the auxiliary box or condulet relative to the main terminal box and the motor frame.

Fig. 5.3

Terminal leads

All NEMA motors come standard with flying leads (no terminal block) terminated using ring terminals. The leads are Class F insulated and identified with permanent marking. Terminal block, **K83**, is available on motors up to 360 frame and only with 3 leads. As standard terminal leads will be of sufficient length to execute the termination to the power leads inside the terminal box. Special cable length, **Y85**, is available on 1LE2 and 1PC2 severe duty motors and may be used to extend the leads up to 120” outside of the motor frame.

3.1.2.5. Bearings and Lubrication

Codes	Description	1LE2	1MB2	1PC2	
A51	BRG RTD's-100 Ohm Platinum - Both Ends & Terminal Heads/Block	+	-	+	
K21	Extra High Thrust	-	-	+	
L54	Provisions for Oil Mist	+	-	-	
L55	Oil Mist Ready	+	-	-	
L57	MOBIL 28-High or Low Ambient - Special Grease	+	+	+	
L58	MOBILITH SHC 100 -Special Grease	+	+	+	
Short Codes	L60	ALEMITE and Grease Relief Fitting	+	-	+
	L61	INSOCOAT Bearing Both Ends	+	+	+
	L64	INSOCOAT Bearing NDE	+	+	+
	L65	Roller Instead of Ball	+	+	-
	L66	Insulated Bearings on Both Ends	+	-	-
	L67	Insulated NDE Only	+	-	-
	L68	Sealed Ball Bearings (Both Ends)	+	+	+
	L69	Hybrid (Ceramic Ball) Bearings – Both Ends	+	+	-
	L70	Hybrid (Ceramic Ball) Bearings – NDE	+	+	+
	L71	Hybrid (Ceramic Ball) Bearings – DE	+	+	+

+ Available • Standard - Not Available Pricing

Lubrication

Standard lubrication for low voltage NEMA motors is EXXONMOBIL POLYREX EM (Polyurea-based grease).

MOBIL 28 Grease, **L57**, has a wide temperature range with a clay base thickener ideal for low ambient conditions down to -50C. This option is supplied as standard for low ambient option codes **B27, B28**, and **B29**.

MOBILITH SCH 100, **L58**, is a Lithium base alternative to our standard POLYREX EM.

Grease inlet (Alemite fitting) is standard on GP100 in frame 280 and larger, and all SD, XP, and DP NEMA products. Grease fittings are not possible on the GP100A product line. SD100 IEEE motors include Alemite and automatic grease relief fittings as standard, **L60** option is available for other severe duty motors.

Oil mist ready, **L55**, and Provisions for oil mist, **L54**, are possible on Severe Duty motors (SD100/ SD100IEEE) 280 to 440 Frames and SD10MS 280 to 440 Frames Horizontal Foot Mount only. Bearings must be single shield ball bearings with shields to inboard side. Motor leads are sealed to prevent mist from entering conduit box and lead material used is resistant to oil mist. Oil mist ready will only have enough grease in the bearings to complete the routine test. Provisions for oil mist will be supplied with grease in the bearing housing which must be expelled prior to switching to oil mist lubrication. Motors with oil mist options will not have grease fittings or grease relief.

Sealed bearings, **L68**, are greased for life bearings and will not require re-lubrication. Sealed bearings with IEEE 841 will result in the motor labeled as “IEEE Std 841-2021 Features”.

Bearings

Low voltage NEMA motor standard re-greaseable bearings have an L10 bearing life of 100,000 hours for direct coupled applications and 50,000 hours for belted applications when properly sized for the application and with proper maintenance. See [Technical Tables](#) section for standard bearings sizes and with option **L65**.

Vertical solid shaft motors, HP100 and LP100, thrust values are published with a bearing life of one year. Extra high thrust, **K21**, changes the NDE thrust bearings to tandem configuration on the LP100 to allow for more down thrust to be considered (see [Technical Tables](#)). API 610, **K20**, does not allow for bearings in tandem and cannot be used with **K21**. With API610 the thrust bearing must be located on the NDE and have a minimum bearing life of 3 years. See thrust values for 3 year bearing life in [Technical Tables](#).

Bearing temperature protection

Bearing RTDs, **A51**, included temperature monitoring on both the drive end and non-drive end bearing. The bearing housing is drilled and tapped for the temperature probe to rest on the outer race of the bearing with the leads in a terminal head on each end (Fig. 6.1). This allows for independent temperature monitoring for each bearing.

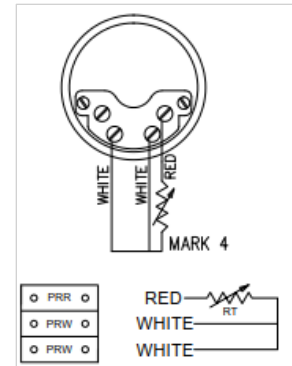

Fig. 6.1

Overhung load/belted considerations

ABB recommends a roller bearing, **L65**, on the DE for overhung load applications. Roller bearing on DE is standard on SD661 product line and on select 440 frame and up as noted in Table 6.1.

Belted details can be evaluated, **F09**, by ABB Engineering on request. The belting form can be requested through the Low Voltage NEMA motor Quotation Team. Minimum criteria for belting evaluation are listed below and cannot be properly evaluated without this data.

- Operating application horsepower (Can be less than the rated motor HP)
- Operating RPM
- Frame size of selected motor
- D_r = Motor sheave diameter (Must be within Table 6.3)
- D_n = Driven sheave diameter
- Number of belts
- Type of belts (e.g., 3V, 5V, 8V, A, B, C, etc.)
- C = Distance between sheaves (center to center)
- L = Distance from center of motor sheave to end of shaft
- Orientation of motor (Horizontal/Vertical shaft up/Vertical shaft down)
- W_s = Face width of motor sheave

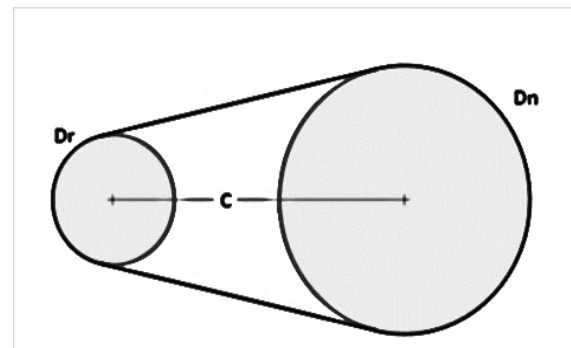
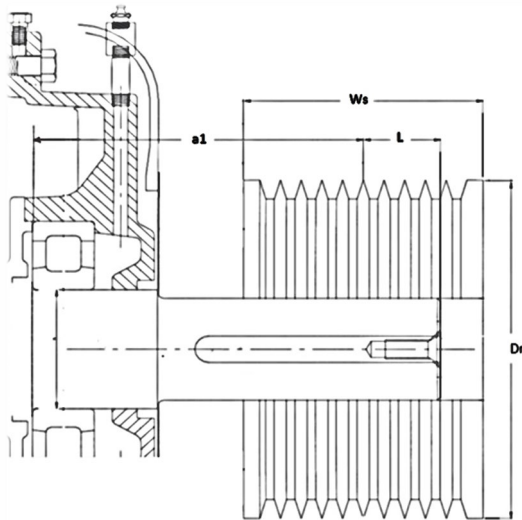

Fig. 6.2

Recommended Sheave Diameters for V-belts

Frame	HP Synchronous RPM			Standard V Minimum Diameter (in.)	Narrow V Minimum Diameter (in.)
	1800	1200	900		
364T	60	--	--	7.4	7.4
365T	75	--	--	9.0	8.6
404T	--	60	--	9.0	8.0
404T	--	--	50	9.0	8.4
405T	100	--	--	10.0	8.6
405T	--	75	60	10.0	10.0
444T	--	100	--	11.8	10.0
444T	--	--	75	13.0	9.5
444T	125	--	--	12.0	10.5
445T	--	--	100	15.0	12.0
445T	--	125	--	15.2	12.4
445T	150	--	--	13.2	10.5
447T	--	150	--	16.1	11.6
447T	--	--	150	24.7	14.6
447T	200	--	--	15.8	13.2
449T	--	200	--	25.0	14.6
449T	--	--	200	--	18.0
449T	250	--	--	18.4	13.0
449T	--	250	--	--	18.2
S449LS	--	--	250	--	19.8
449T	300	--	--	24.8	15.4
S449LS	--	300	--	--	18.4
S449LS	350	--	--	--	15.8
S449LS	--	350	--	--	21.0
S449LS	400	--	--	--	18.0

Table 6.3

Narrow V Example: 3V, 5V, 8V

Standard V Example: A, B, C, D section

Do not exceed belt service factor of 1.6

Maximum speed reduction of 5:1

Shaft center distance approximately equal to diameter of largest sheave

The motor sheave should be located as close as possible to the bearing (1/2" from shaft shoulder)

The center of the belt system should never extend beyond the end of the motor shaft

VFD application considerations for bearings

Shaft currents caused by VFD supply can cause damage to bearings that can result in bearing failure. The shaft currents tend to increase as the frame size increases. ABB recommends the use of an insulated bearing on the NDE of frames 400 and larger to reduce the risk of the shaft current passing through the bearing.

Insulated bearings, **L66** and **L67**, use a non-conductive insulating sleeve inserted into the bearing housing. This option is effective in reducing the shaft currents and uses sealed bearings making the bearings non-regreasable. **Note: Not available for roller bearing on DE or load bearing on NDE (LP100). Not to be used with bearing RTDs, A51.**

Hybrid ceramic bearings, **L69**, **L70** and **L71**, are a direct replacement for the standard bearing size and are fully regreasable. They utilize ceramic balls to eliminate the currents from passing through the bearings. **Note: Not available for roller bearing on DE or load bearing on NDE (LP100).**

INSOCOAT Bearings, **L61**, **L64**, are a direct replacement for the standard bearing size and are fully regreasable. An insulated coating on the outer race of the bearing is used to reduce the risk of the currents passing through the bearing. **Note: Not available for load bearing on NDE (LP100).**

See Shafts and Seals for additional options to reduce bearing damage due to shaft currents.

3.1.2.6. Shafts and Seals

	Codes	Description	1LE2	1MB2	1PC2
Short Codes	K41	Keyless Shaft	+	+	+
	L29	Shaft Grounding Brush	+	-	-
	L76	Shaft Slinger & O Ring	+	+	+
	L79	INPRO/SEAL DE	+	+	+
	L80	INPRO/SEAL NDE	+	+	+
	L81	INPRO/SEAL Both Ends	+	+	+
	L84	Brass Seal	+	+	+
	L86	INPRO/SEAL MGS Shaft Grounding - DE	+	-	+
	M42	Shaft Ring Brush (Steel) - NDE (AEGIS)	+	-	-
	M52	NEMA Std Long Shaft - NDE	+	+	-
	M53	NEMA Std Short Shaft - NDE	+	+	-
	M57	(C4140) Carbon Steel Shaft	+	+	+
	Y50	Special Shaft on Drive End	+	+	+
	Y51	Special Shaft on Non-Drive End	+	+	-

+ Available • Standard - Not Available Pricing

Shafts

The standard shaft material will be C1045 or C4140 as noted in Table 7.1. C4140 shaft material is available as a custom option, **M57**, on frames with C-1045 as standard. ABB NEMA motors are designed with the shaft dimensions and tolerances to meet the standards of NEMA MG-1 single shaft extension. Any exceptions will be noted on the motor drawings.

Frame	Standard Shaft Material
140-449	C-1045
S449	C-4140

Table 7.1

Motors can be custom built with a double shaft extension with NDE shaft according to NEMA MG-1. This can be offered as either long shaft, **M52**, or short shaft, **M53**. See drawings and dimensions for reference.

Motors can be custom built with a special shaft extension on DE, **Y50**, or NDE, **Y51**. These options can be used for special dimensions or special shaft features (ex: drill and tap, threaded shaft, special keyway, etc.) and must be quoted by the ABB NEMA Motor Quotation Team.

Keyless DE shaft extension, **K41**, is available as a custom feature. All other shaft dimensions will remain in accordance with NEMA MG-1 (unless otherwise noted in drawing).

Seals

Shaft seals are used to protect the bearings from liquid and dust contaminants that lead to premature bearing failure. NEMA motor are equipped with v-ring shaft seals as standard on all General Purpose motors and severe duty motors unless otherwise noted. The v-ring shaft seal provides protection to meet IP55.

Labyrinth seals (Inpro Seals, **L79**, **L80**, and **L81**), are shaft rotating seals that provide extra ingress protection from water and dust while the motor is in operation. Motors that are noted to meet IEEE 841 or when IEEE 841 features, **K10**, will include labyrinth seals on both ends.

Shaft slinger and O-ring, **L76**, is used in shaft up applications to help reduce liquid from running down the shaft and settling in the seal area.

VFD application considerations for shaft grounding

Shaft grounding can reduce the risk of shaft currents from passing through the bearings.

This allows the current generated in the shaft to flow harmlessly to the frame and ultimately to ground bypassing the bearings in the process. Shaft grounding options are considered sparking devices and cannot be used in hazardous areas. When selected for SD products, the Division 2 information will be removed from the nameplate.

SGS™ MOTOR GROUNDING BRUSH & RING SYSTEMS, **L29**, mounts on the fan housing with a carbon brush that contacts the motor shaft. The carbon brush is rated at 100,000 hours before being changed. **Note: Not possible in combination with G05, G06, H04, M08, or Y51.**

Bearing Isolator + grounding brush, (MGS INPRO Seal, **L86**), uses the labyrinth sealing protection of an Inpro Seal combined with shaft grounding brushes that rest on the shaft behind the sealing mechanism. The brushes reduce the shaft currents from passing through the bearings while the seal reduces contamination build up on the grounding brushes and in the bearing. **Note: This option may reduce the usable shaft length.**

AEGIS grounding brush, **M42**, can be added to the NDE on GP100 motors.

3.1.2.7. Frame

	Codes	Description	1LE2	1MB2	1PC2
Short Codes	K33	Drip Cover	+	+	•
	K34	Vertical Lifting Devices (No Drip Cover)	+	+	•
	K38	Provisions for Dowel Holes	+	+	–
	K70	Rotation Arrow Bidirectional	+	+	+
	K71	Rotation Arrow Clockwise (from NDE)	+	+	+
	K72	Rotation Arrow Counterclockwise (from NDE)	+	+	+
	L20	Lifting Eyebolt	+	•	•
	L22	Stainless Steel Hardware (Includes T Drain SS)	+	–	+
	L27	Ground Bolt	+	+	+
	L45	SS T-Slot Breather Drain	+	–	+
	L46	CROUSE HINDS UL Approved Breather Drain	+	+	+
	L90	IP66 Ingress Protection	+	+	–
	L91	IP56 Ingress Protection	+	–	–
	L92	IP65 Ingress Protection	+	–	–
	M09	Aluminum Fan	+	–	–
	M10	Bronze Fan (S440 - Std)	+	–	+
	M28	Stainless Steel Eyebolt	+	+	–
	M39	Vertical Jacking Provisions	+	+	–

+ Available • Standard – Not Available Pricing

Feet

Motors with cast iron frame will have cast in feet as standard.

Provisions for dowel holes, **K38**, provides a hole drilled at an angle in each of the motor feet. The holes will be used as a guide for drilling the mounting plate for the addition of the dowel once the motor is aligned to the driven equipment. Dowels can be used to pinpoint the alignment of the motor to the driven equipment when the motor is taken out for service.

Motors will be delivered as standard with dual/tri drilled mounting holes in the feet for increased flexibility in mounting.

Provisions for vertical jacking, **M39**, provides threads in the non-mounting holes on the feet in order that a bolt may be added for leveling of the motor during installation. Jacking provisions are required on motors that exceed 500 lbs to meet API610 requirements for horizontal pump applications.

The GP100A aluminum frame includes bolt on feet, 140-250 frames, for flexibility within the field changes.

Lifting

Horizontal cast iron motors up to S449 will be supplied with an eye bolt located in the center line of the center of gravity on the motor frame. GP100 140 frame must include, option **L20**, for eyebolt to be included.

Vertical lifting devices, **K34**, are closed hooks used for vertical lifting and will be supplied with one on each side of the motor. Vertical lifting devices are standard when mentioned in the mounting description for Position 14 of the MLFB and on the LP/HP motors. Vertical lifting devices are only available on round frame motors.

Fan and fan cover

The standard bidirectional cooling fan is non-sparking polypropylene design, unless otherwise noted. Directional fans will have polypropylene blades with metallic mounting. Bronze fans, **M10**, are non-sparking and may be used on bi-directional motors. Aluminum fans, **M09**, may only be used on safe area motors and do not comply with IEEE 841 standards.

NEMA motors are supplied as either bi-directional or clockwise as standard (directional motors will be noted in motor selection section) as viewed from Non-Drive End (NDE).

Rotation arrows, **K70**, **K71**, **K72**, can be added to the fan housing for clarity. Motors supplied as unidirectional will have a rotational arrow as standard. Option **K72** can be used to achieve counterclockwise rotation on a motor that has clockwise as standard (this will make the motor MOD or Custom). Options K71 and K72 do not change the motor fan when applied to a bidirectional motor.

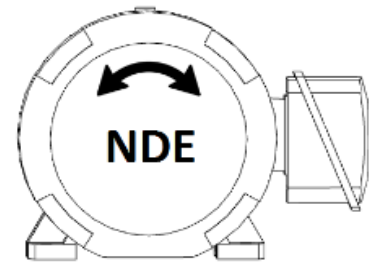

Cast iron fan cover will be included as standard on all SD motors. General Purpose motors will include fan cover in material mentioned in Table 8.2.

General Purpose Fan Cover Material

Motor Type	Frame	Material
GP, GPA	140-250	Polyamide
GP	280-320	Plate Steel
GP	360-440	Cast Iron

Table 8.2

Drip cover, **K33**, can be added to the fan cover of motors used in vertical shaft down applications in order to protect the motor from water or liquids from falling directly into the fan housing.

Drip cover is standard when mentioned in the mounting description for Position 14 of the MLFB and on the LP/HP motors. See Table drawing and dimensions for drip cover dimensions.

Hardware

Standard hardware is grade 5 zinc plated corrosion resistant hardware. Stainless steel hardware, **L22**, includes all external nuts and bolts as well as the T-Drain. Stainless steel eyebolt, **M28**, is not included with **L22**. Stainless steel hardware is included with option, **B29**, for low ambient temperature and is not available on XP motors. Stainless steel T-drain, **L45**, will include only the drain as stainless steel.

All NEMA motors will include tapped holes on each side of the frame near the feet for frame grounding. Bronze ground bolt, **L27**, can be added for additional provisions.

Various types of drains are used based on the motor types (see motor type introduction for clarity). Drain plugs require the user to unscrew the plug to allow the moisture to escape during times of idle use. T-slot drains allow for moisture to drain from the motor freely without user intervention. Crouse Hinds drains, **L46**, are UL approved drains that can be added on frames 280 and larger. The Crouse Hinds drain is standard on XP motors in frame 280 and larger.

Ingress protection

The ingress protection (IP) rating is the protection grade against water and dust. The IP rating on the nameplate applies to completed motor, including shaft seals, bearing housing fits, and terminal box. The first number designation in the IP rating, IP_*, relates to the protection against water. The second number designation in the IP rating, IP*_*, relates to the protection against dust. GP100 motors will have a standard IP54 rating. Severe Duty and Definite purpose motors will have a standard IP55 rating that can be increased up to IP66 with options **L90**, **L91**, **L92**. Explosion proof motors have a standard IP65 rating that can be increased to IP66 with option, **L90**.

3.1.2.8. Rating Plates and Tagging

Codes	Description	1LE2	1MB2	1PC2
C40	Re-rate 400V to 380V, 50HZ	+	+	+
C41	Re-rate 400V to 415V, 50HZ	+	+	+
M21	Additional Nameplate (Without Logos)	+	+	-
M25	Class II, Division 2, Groups F & G, T3C Temp Code	+	-	+
M32	Class II, Group E Hazardous Area	-	+	-
Y80	Derate-Altitude-Ambient (Nameplate Change)	+	+	+
Y82	Auxiliary n/p Max. 40 Characters (Aux Tag)	+	+	+

Short Codes

+ Available • Standard - Not Available Pricing

Main nameplate

Duplicate rating plate

A rating plate similar to the original nameplate, **M21**, can be supplied with the motor attached to the eyebolt during shipment. The **M21** plate can only be supplied without the logos on the plate.

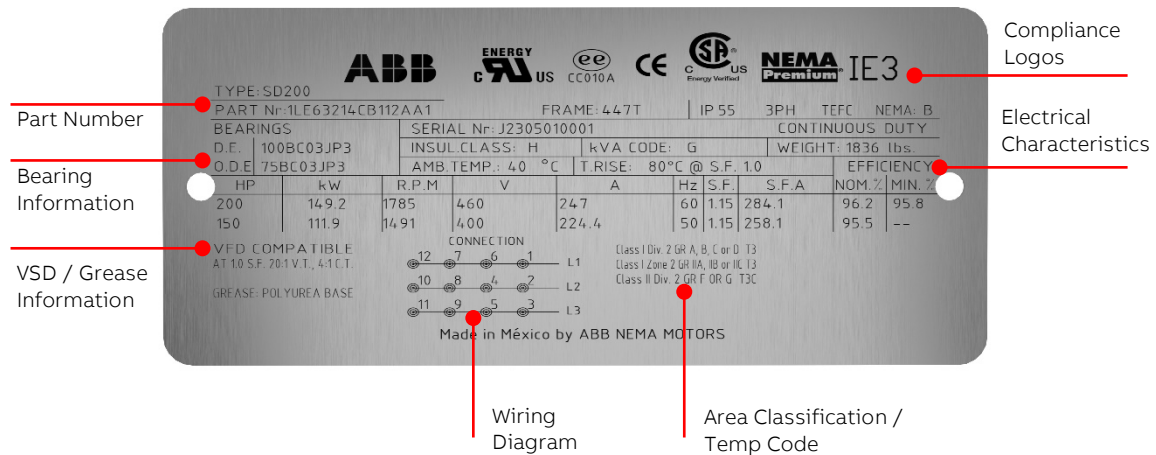

Compliance logos

Compliance logos and certifications will change based on the motor line and/or nameplate language.

Electrical characteristics

Beginning in 2022 nameplates for 2, 4, and 6 pole motors will include 50Hz information at 400V, 50Hz with decreased output. This data can be replaced with 380V, option **C40**, or 415V, option **C41**. **Note: SD100 IEEE841 and SD661 will not have 50Hz as standard.**

Motor main nameplate may be modified, **Y80**, for de-rate, re-rate, deviated altitude, deviated ambient, or information added to the main nameplate. Information must be consistent with guidelines listed in catalog for de-rate or re-rate and within the limitations set in the ambient and altitude section (unless custom quotation is referenced).

Note: ABB reserves the right to reject/ hold an order based on inconsistent information or the lack of information provided for option Y80. When additional information is requested on the nameplate, it may result in standard information being displaced or removed due to space restrictions.

Hazardous area classification

All ABB Severe Duty low voltage NEMA motors and Definite Purpose low voltage NEMA motors will be tagged as Class I, Division 2 as standard.

SD100 motors in frames 280 to 400 and all SD100 IEEE841 will be supplied with Class II, Division 2 standard on the main nameplate see figure 9.1.

Separate Division 2, Class II, **M25**, can be supplied when required. The motors will be equipped with additional features and tagging figure 9.3.

Division 2 information will not be included when one of the following options are selected: **L29, L86** or any other feature that may be deemed as a sparking device.

Explosion proof motors will have a separate UL tag with the area classification defined as per Figure 9.4. Class II, Division 1, Group E hazardous area, **M32**, can be added on the XP100 motor line as a custom build.

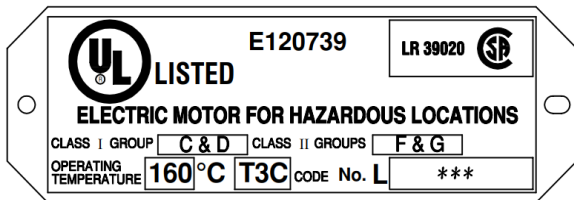

Fig. 9.4

Auxiliary plates

An auxiliary tag, **Y82**, may be provided separate from motor nameplate. This tag can be used for free text provided by customer in PO. This is often used for customer tagging or customer instructions. The tag has a character limit of 40 which includes spaces and special characters. **Note: ABB will not be held accountable for free text provided by customer that is provided in the PO that proves to be inconsistent with the motor design (unless specified in an ABB custom quotation, Figure 9.5).**

A separate lubrication plate, **M24**, may be added for additional details on motor lubrication (see example Figure 9.6).

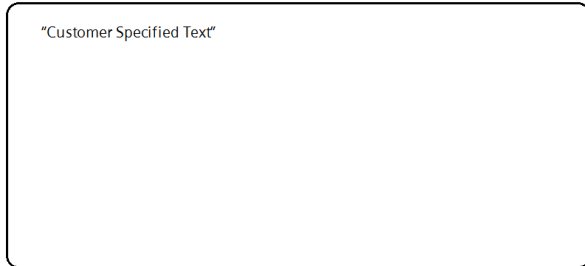

Fig. 9.5

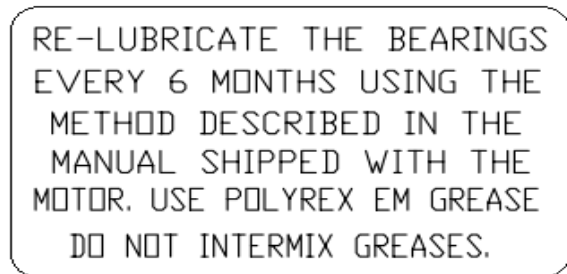

Fig. 9.6

3.1.2.9. Ambient and Altitude

	Codes	Description	1LE2	1MB2	1PC2
Short Codes	B27	+40°C to - 30°C Ambient Temp	+	-	+
	B28	+40°C to - 40°C Ambient Temp	+	-	+
	B29	+40°C to - 50°C Ambient Temp	+	-	+

+ Available • Standard – Not Available Pricing

Standard ambient and altitude

ABB General Purpose and Severe Duty NEMA motors are suitable for operation at an altitude up to 3300 feet (1000 meters) above sea level with an ambient temperature range of -25°C to 40°C with 1.15 service factor as standard.

ABB Explosion proof motors up to 320 frame will have a standard maximum ambient temperature of 55°C with 1.15SF, 360 frame and up can be offered with 55°C with **MLFB position 15 “T”** see [Winding Protection](#) and will have a T3 temp code (449T will have a 1.0SF at 55°C). Explosion proof Division 1 motors cannot be offered at an ambient below -25°C.

Increased ambient or altitude

Altitude can be adjusted up to 9900 feet or Ambient can be adjusted up to 55°C with a reduction in service factor to 1.0 using **Y80** option code.

Altitude may also be increased with reduction in ambient per Figure 10.1.

For altitude above 9900 feet or ambient above 55°C please contact the ABB NEMA Motor Quotation Team.

Maximum Altitude	Maximum Ambient
3300 ft (1000m)	40°C (104°F)
6600 ft (2000m)	30°C (56°F)
9900 ft (3000m)	20°C (68°F)

Table 10.1

Low ambient conditions

Ambient temperatures below -25°C can cause standard grease to become ineffective and some standard metals to become brittle leading to motor failure or damage. Features for low ambient conditions can be added a custom build, **B27** for down to -30°C, **B28** for down to -40°C, **B29** for down to -50°C, include special grease, external hardware, shaft material, lead material, and seals for suitability for the low temperatures.

3.1.2.10. Mechanical Design & Accessories

Codes	Description	1LE2	1MB2	1PC2	
A66	ROBERT SHAW Vibrator Detector Model 366 - D8 120VAC	+	-	-	
A67	Provision for Vibration Sensors	+	-	-	
G05	DYNAPAR Encoder HS35R 1024 PPR	+	-	+	
G06	C-Face Mounted SLIM Tach Encoder	+	-	-	
Short Codes	H04	C-Face Mounted Brake	+	-	-
	K10	IEEE 841 Features	+	-	+
	K20	API 610	-	-	+
	M05	Larger Fan	+	+	-
	M08	Separately Driven Fan	+	-	-
	M18	Non-Reverse Ratchet	-	-	+
	M69	Precision	+	+	+
	M70	Extra Precision Balance	+	+	+

+ Available • Standard - Not Available Pricing

Standards

IEEE 841 Features, **K10**, adds the applicable features of IEEE 841 to the motor. The motors will be nameplated according to IEEE Std 841-2021.

API610, **K20**, provides the stringent guideline of API610 pumps to the LP100 motor line with high thrust. API610 is not available with extra high thrust, **K21**. See Bearings and Lubrication section for additional information.

Balance

All low voltage NEMA motors are dynamically balanced to commercial limits measure in accordance with NEMA MG1-12.06. Precision and Extra Precision balance, **M69**, **M70**, provides more stringent balancing guidelines (see Technical Tables for values).

ACCESSORIES

Vibration monitoring

ROBERT SHAW Malfunction vibration detectors, **A66**, are a single point vibration monitoring switch. This is designed to trip and shut down the motor in the event of excessive vibration.

Provisions for vibration sensors, **A67**, will provide 1/4"–28 UNF drilled and tapped holes on each bearing housing when selected with no additional instruction. This option can also be adapted to the required drill and tap required for a customer specified vibration sensor with quote from LOW VOLTAGE MOTOR quotation team.

Encoders

DYNAPAR HS35R, **G05**, is a hollow shaft rotary pulse 1024 PPR encoder with single output. It is mounted on an NDE shaft extension that extends beyond the fan housing. It is held in place with an arm that is attached to the fan housing.

SLIM Tach ST56 for 140-250 frames or ST85 for 280-S449, **G06**, is a c-face mounted 1024 PPR encoder with single output. See [Drawings and Dimensions](#) for Encoder dimensions.

Brake

C-Face Mounted Brake, **H04**, will be a Stearns brake, rated IP55, rigidly mounted to the NDE of the motor with a special designed bearings housing with C-face for mounting the brake.

Brakes will be supplied with rated supply voltage equivalent to the motor voltage. See [Drawings and Dimensions](#) for basic brake data.

Additional cooling for VFD applications

Larger Fan, **M05**, can be added on select 2, 4, and 6 pole motors in frames 360-444 to provide additional cooling and extended speed range for constant torque. See [Technical Tables](#) for new range. The motor will be labeled as VFD only and the NEMA Premium logos will be removed from the nameplate.

External Force cooling, **M08**, can be added to severe duty motors for increased turndown on VFD applications, see [Drawings and Dimensions section](#). The blower motor voltage will follow the voltage of the drive motor. The addition of the blower will increase the constant torque turndown to 1000:1. Class H insulation, **C00**, and Spike Resistant Wire, **C03**, and bearing insulation for frame 360 and above is also recommended for 1000:1 CT applications.

Others

Non-Reverse Ratchet (NRR), **M18**, prevents the opposite rotation of the shaft on the LP100 motor line. NRR is only available for standard clockwise rotation. This device is not suitable for hazardous locations and the standard Division 2 information will be removed from the nameplate.

3.1.2.11. Paint and Packaging

	Codes	Description	1LE2	1MB2	1PC2
Short Codes	B07	Stackable Crate Packing	+	+	-
	B09	Export Packaging Sea freight – ABB Standard	+	+	+
	B11	Export Packaging Sea freight – ABB Standard + sensors	+	+	+
	N01	2 Part Epoxy (Industrial-Coastal Low Salt)	+	+	+
	N02	3 Part Epoxy (Industrial-Coastal Moderate Salt)	+	+	+
	N03	Primer Only	+	+	+
	N05	3 Part Epoxy (Coastal-Offshore High Salt)	+	+	+
	N06	2 Part Epoxy C4 (Industrial-Coastal Moderate Salt)	+	+	+
	N07	2 Part Epoxy C5I/C5M (Coastal-Offshore High Salt)	+	+	+
	Y60	Special color (Provide RAL#)	+	+	+
	Y61	Special color with Special Paint system (Provide RAL#)	+	+	+

+ Available • Standard – Not Available Pricing

Packaging

Frames 280 and larger will be bolted to an open wood pallet and wrapped in plastic to protect the finish. See standard packaging weights in dims in [Drawing section](#).

Stackable crate packing, **B07**, will have supported wooden slates on all sides surrounding the motor. This packing is available for frames 280 – 400 and provides additional protection during transport and allows for the motors to be stacked on the floor in a warehouse.

Export packing, **B09**, the motor will be secured into a fully enclosed wood crate. See Export box weights and dimensions in [Drawing section](#). Special packing, **B11**, will include B09+shock and tilt sensors.

Shipping weights and dimensions can be calculated using the standard packing weights and dimensions table combined with the motor information. The weights and dimensions listed in the tables do not include the weight and dimensions of the motor unless otherwise noted.

Paint

NEMA motors as standard are protected against corrosion (C2 category) and external influences with high-quality coatings based on (Alkyd Modified + Epoxy). If a higher corrosive class is required, a special paint system must be included.

Motors can be provided with primer only, **N03**, to allow the customer to apply their own final paint in the field.

The 2 Parts Epoxy paint system, **N01**, offers excellent resistance to the corrosive action of chemical agents, prolonged weathering and to the action of direct sunlight.

The 3 Parts Epoxy paint system, **N02**, is an organic base of Epoxy Zinc, provides a high resistance to humid environments (saline or no-saline) but not for offshore ocean climate, excellent inhibitory capacity to corrosion, excellent resistance to abrasion, high temperatures (ambient temperatures > 59°C) and to the

most of industrial solvents (splashes). This Paint System is recommended to apply in high relative humidity environments (>60%).

2 Parts Epoxy paint system, **N06**, offers the same level of protection as **N02** at a reduced price and shorter process time.

The 3 parts epoxy (Coastal-Offshore High Salt) paint system, **N05**, is recommended for offshore installation, provides good chemical resistance to splash/spillage, fumes and immersion in neutral, fresh and salt water. Effectively protects the motor from corrosion resulting from industrial and marine exposures as it is safeguarding the environment.

2 Parts Epoxy paint system, **N07**, offers the same level of protection as **N05** at a reduced price and shorter process time.

See [Technical Tables](#) for additional details.

3.1.2.12. Documentation

	Codes	Description	1LE2	1MB2	1PC2
Short Codes	D05	Documentation in Spanish	+	+	+
	F00	Certificate of Compliance	+	+	+
	F01	Certificate of Origin - Stamped by Chamber of Commerce	+	+	+
	F03	Standard Performance Curve	+	+	+
	F04	Acceleration Time Calculation	+	+	+
	F05	Polarization Index	+	+	+
	F07	Curve Package at 100% and 80% voltage (S-T, PERF)	+	+	+
	F08	Shaft Torsional Analysis (includes shaft sketch)	+	+	+
	F09	Bearing L10 Calculation	+	+	+
	F40	Stall Time (Thermal Limit Curve)	+	+	+
	F42	Standard Dimension Sheet	+	+	+
	F43	Nonstandard Dimension Sheet	+	+	+
	F44	Conduit Box Dimension Sheet	+	+	+
	F45	Wiring Diagram	+	+	+
	F46	Instruction and Operation Manual	+	+	+
	F47	Renewal Parts	+	+	+
	F48	CAD Drawing (Dwg Format) Customer/Application Specific	+	+	+
	F49	Performance Data Sheets	+	+	+
	F50	Customer Specific Data Sheets	+	+	+
	F51	Shaft Profile Detail (included materials data)	+	+	+
	F60	Visual Inspection Proof (Max 8X Photos)	+	+	+
	F70	Inspection Test Plan	+	+	+
F71	Paint Report (thickness and adherence)	+	+	+	
F81	Advanced Document Package	+	+	+	
F82	Project Document Package	+	+	+	

+ Available • Standard – Not Available Pricing

ABB offers much of our documentation and certificates for download through ABB’s Motor Builder at <https://motorbuilder.abb.com>. This allows the data to be tailored to the motor configuration.

In addition to our online documentation, we also offer a wide variety of order specific documentation through order codes as individual documents or as documentation packages. Ordered documents be provided in ABB standard electronic format unless otherwise noted. Information that is proprietary to ABB will not be included in documentation supplied.

Drawings

Motor drawings can be provided in either pdf or dxf format as specified in the purchase order. The standard drawing, **F42**, can be used for a standard F1 configuration with no special options. This drawing is also available for download through ABB's Motor Builder at <https://motorbuilder.abb.com>.

The non-standard drawing in pdf format, **F43**, or in CAD (.dxf) format, **F48**, can be used for motors with mechanical modifications that would add on accessories or change the standard dimensions of the motor.

Conduit box drawing, **F44**, can be used for a standard conduit box drawing and auxiliary boxes.

Shaft Profile Detail, **F51**, provides a shaft profile drawing with limited dimensions and shaft material data.

Curves

Standard performance curves, **F03**, will include the motor calculated speed torque curve and calculated performance curve (Efficiency, Power Factor, and Amps Over percent of rated horsepower) at rated voltage. This curve is also available for download through ABB's Motor Builder at <https://motorbuilder.abb.com>.

Stall Time Curve, **F40**, is a logarithmic curve of current (in present of full load) over time. The curve will be shown for both hot and cold conditions and graphically illustrates the safe stall time.

Curves at 100% and 80% voltage, **F07**, will include speed torque curve and performance curves.

Data sheets

Typical Data sheet, **F49**, will provide an electrical data sheet for the motor ordered in ABB standard format.

Customer specific data sheet, **F50**, provides the customer with the project data sheet filled out by ABB Engineering. The customer data sheet must be supplied in excel format at the time the purchase order is placed.

Special calculations and reports

Acceleration time calculation, **F04**, will be calculated based on the load inertia value provided by the customer. The inertia value must be provided with the PO.

Polarization Index, **F05**, provides a reference winding impedance to gauge deterioration of the winding insulation.

Shaft Torsional Analysis, **F08**, provides motor shaft torsional data for each step on the shaft with the shaft drawing.

Bearing L10 calculation, **F09**, calculates the estimated life of the bearings based on customer supplied application details. See [Bearings section](#) for minimum application details required.

Other Documentation

Documentation and nameplates can be provided in Spanish, **D05**. This option will also include NOM on the nameplate.

Certificate of compliance, **F00**, can be issued to certify compliance with ISO standards.

Certificate of origin stamped by the Chamber of Commerce, **F01**, can be required when motors are exported for select countries.

Inspection Test Plan, **F70**, provides formal documentation of the factory standard tests and inspections.

Wiring diagram, **F45**, will provide a pdf copy of the motor wiring diagram for the motor ordered. This document is also available for download through ABB's Motor Builder at <https://motorbuilder.abb.com>.

Instruction and Operation Manual, **F46**, is general instructions for installation, operation and maintenance for NEMA motors. This document is also available for download through ABB's Motor Builder at <https://motorbuilder.abb.com>.

Replacement parts list, **F47**, will provide part numbers and general descriptions for the following spare parts:

- Bearings, Fan, Fan housing, Conduit Box, Bearing housings (flange if applicable), and seals.

Visual inspection Proof, **F60**, provides up to 8 photos of the motor prior to shipment. Photos will include nameplate and tagging, at least 3 views of overall motors, and detail special features.

Paint Report, **F71**, provides a measure of paint thickness and overall paint adherence.

Additional specialized documentation and calculations may be offered by the factory through the ABB NEMA Motor Quotation Team.

Documentation packages

Order specific documentation packages provide many of the common documents required for special projects and OEMs packaged into a zip file. Additional documentation options may be added with order codes as required by the project.

Advanced Document Package, **F81**, will include:

- (F46) Instruction Operation Manual
- (F00) Certificate of Compliance
- (F49) Data Sheet
- Nameplate Drawing
- (F45) Connection Diagram
- (F07) Curves (at 80% and 100% Voltage)
- (F47) Spare Parts List
- (F43) Outline Drawing (pdf)

Project Documentation Package, **F82**, will include:

- (F46) Instruction Operation Manual
- (F00) Certificate of Compliance
- (F49) Data Sheet
- Nameplate Drawing
- (F45) Connection Diagram
- (F07) Curves (at 80% and 100% Voltage)
- (F47) Spare Parts List
- (F43) Outline Drawing (pdf)
- (F48) CAD Dimension drawing
- Thermal Limit Curve
- (F44) Terminal box drawing
- (F50) Customer specific data sheets
- (F70) ITP
- Hazardous Area Certs (UL or CSA)
- Details of Paint System

3.1.2.13. Tests

	Codes	Description	1LE2	1MB2	1PC2
Short Codes	F10	Routine Test Report	+	+	+
	F12	Routine Test Report (Witnessed)	+	+	+
	F15	Complete Test	+	+	+
	F17	Complete Test (Witnessed)	+	+	+
	F20	Routine Test + Vibration	+	+	+
	F22	Routine Test + Vibration (Witnessed)	+	+	+
	F27	Performance Load Test (Curve Report)	+	+	+
	F30	Noise Test	+	+	+
	F32	Noise Test (Witnessed)	+	+	+
	F36	Routine Test Report of Electrical Duplicate Design	+	+	+
	F37	Type Test Report of Electrical Duplicate Design	+	+	+

+ Available • Standard – Not Available Pricing

Routine Test, F10, F12

Routine test consists of the following items tested in accordance with IEEE standard 112.

- No Load Current
- No Load Speed
- Nominal Current at Locked Rotor
- Winding Resistance
- High Potential
- Bearings/Vibration Check

Routine Test with vibration, F20, F22

Includes all tests from standard routine test with additional records of vibration testing. A hard copy of the Routine Test with vibration is included on all IEEE 841 compliant motors, adding **F20** will get you the test report in electronic format.

Test report of routine test is based on IEEE Std. 112 Form A-1 and includes complete nameplate information.

Electrical Duplicate Routine Test, **F36**, is an electronic copy of a test report of the same electrical design as the motor on order.

Performance Load Test, F27

Performance Load Tests the motors at select points from 0-125% of the rated load recording speed, torque, current, power factor and efficiency, at rated voltage. Data is curve plotted, on ABB standard format. Foot mounted motors only.

Complete Test, F15, F17

Complete test consists of the following items tested in accordance with NEMA and IEEE-112 test standards.

- Full Load Heat Run
- Temperature Rise at F.L.
- Winding Resistance
- Rated F.L. Slip
- No Load Current
- Breakdown Torque
- Locked Rotor Torque-Amps
- High Potential Tests
- Efficiencies @ 100, 75, 50 Percent Load
- Power Factor @ 100, 75, 50 Percent Load

Test report of complete test is based on IEEE Std. Form A-2 and includes complete nameplate information.

Electrical Duplicate Complete Test, **F37**, is an electronic copy of a test report of the same electrical design as the motor on order.

Noise Test, F30, F32

Motors are tested according to IEEE 85 standard in unloaded condition only. Test report will be provided with Sound Pressure (L_p) and sound power (L_w) in octave bands of 125Hz, 250Hz, 500Hz, 1kHz, 2kHz, 4kHz, and 8kHz.

3.2. Motor selection and pricing

3.2.1. General Purpose Low Voltage NEMA Motors

Introduction

ABB General Purpose low voltage NEMA motors are designed and built to operate in a variety of commercial and industrial environments. These motors are design to meet or exceed the NEMA Premium® efficiency (MG1 Table 12.12). A wide selection of options makes them suitable for a variety of applications. The construction of these motors is backed up by its 18-month warranty.

Performance Specification



		GP100A	GP100
HP Range	3600 RPM	1-20 HP	1-200 HP
	1800 RPM	1-20 HP	1-200 HP
	1200 RPM	1-20 HP	1-200 HP
	900 RPM	–	1-125 HP
Frame Size	140T - 440T	140T-250T	140T-449T
Standard Voltage (3 phase)	230V/460V (Suitable for 208V)	FS 140-250	FS 140-250
	230V/460V	1-20 HP	Up to 75 HP
	460V	1-20 HP	1-200 HP
	575V	1-20 HP	1-200 HP
Efficiency	NEMA Premium® (MG1-Table 12-12)	1-20 HP	1-200 HP
	NEMA Premium® Plus (>MG1-Table 12-12)		1-20 HP
Service Factor	1.15 @ 40°C	FS 140-250	FS 140-440
Insulation	Non-Hygroscopic		Class F
Temperature Rise	Class B		@ 1.0SF
	Class F		@ 1.15SF
Conduit Box (Oversized)	Oversized	Aluminum	Steel
		FS 140-250	FS140-400
			Cast Iron - FS400
Fan Cover		Plastic	Plastic/Steel/Cast Iron
Cooling Fan	Bi-Directional		Polypropylene
Rotor	Die Cast Aluminum	FS 140-250	FS 140-449
Ingress Protection	NEMA MG1		IP55
Hazardous Location	Safe Area	FS 140-250	FS 140-440
Inverter Duty ⁵	Variable Torque VT 20:1	FS 140-250	FS 140-440
	Constant Torque CT 4:1	FS 140-250	FS 140-440

Frame and end shields

The General Purpose low voltage NEMA Motors are available in two different lines, GP100 which features a cast iron frame and end shields and GP100A with aluminum frame and end shields. Both offer an aluminum, easy-to-access, diagonally -split, oversize terminal box; the terminal box includes a heavy-duty ground lug and non-wicking clearly and permanently marked leads. These characteristics, its zinc-plated hardware, epoxy paint, and stainless-steel nameplate provide exceptional structural integrity and resistance to rust and corrosion, and make them ideal for use in material handling, pump, fan compressor, and other industrial and commercial applications.

Rotor and stator windings

A unique offset rotor bar design provides improved efficiency, while larger bars and end rings reduce resistance for lower rotor losses. Each die cast aluminum rotor assembly is dynamically balanced for extended bearing life and includes a high-strength carbon steel (C1045) shaft for maximum rotor performance. The stator is manufactured with premium electrical C5 grade steel lamination and copper electrical magnet wire that furthers the reduction in losses.

Insulation

The proprietary Class F non-hygroscopic insulation system, NEMA Class B temperature rise, provides an extra margin of thermal life. The varnish system application ensures maximum wire penetration to provide protection from moisture, corrosion, and electrical shock. This insulation system meets or exceeds NEMA MG1 2014 Part 31 making the motors suitable for variable speed drives in constant torque (up to 4:1) and variable torque (20:1). All windings are tested for CIV.

Cooling system

A non-sparking, bi-directional fan is locked and keyed to the shaft. Its low-inertia design reduces windage losses, improves airflow, reduces noise, and provides dependable cooling. A durable and rigid plastic fan cover is offered on every frame size.

Bearings

The motors are equipped with antifriction ball bearings, double shielded up to frame size 250 for the drive end and frame size 280 and above on the non-drive end; Frames 280 and above are provided with single shielded bearings on the drive end and they are also available with roller bearings, when roller bearings are used, the non-drive end will be equipped with single shielded bearings.

3.2.1.1. GP100A

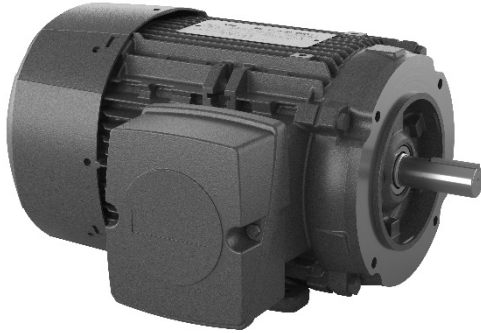

GP100A | Eff: NEMA Premium | 230/460V | Ball Bearing | Long Shaft | Foot Mounted

Power HP	Speed RPM	NEMA Frame	Voltage	Base Part Number	Stock	List Price	Eff %	Weight (lbs)
2 Pole								
1	3600	143T	230/460	1LE21211AA114AA3	+	429	82.5	29
1 ½	3600	143T	230/460	1LE21211AA214AA3	+	440	84.0	35
2	3600	145T	230/460	1LE21211AA314AA3	+	511	85.5	38
3	3600	182T	230/460	1LE21211CA114AA3	+	570	86.5	57
5	3600	184T	230/460	1LE21211CA314AA3	+	741	88.5	67
7 ½	3600	213T	230/460	1LE21212AA114AA3	+	969	89.5	100
10	3600	215T	230/460	1LE21212AA214AA3	+	1142	90.2	113
15	3600	254T	230/460	1LE21212BA114AA3	+	1493	91.0	196
20	3600	256T	230/460	1LE21212BA214AA3	+	1848	91.0	231
4 Pole								
1	1800	143T	230/460	1LE21211AB214AA3	+	429	85.5	41
1 ½	1800	145T	230/460	1LE21211AB314AA3	+	471	86.5	47
2	1800	145T	230/460	1LE21211AB414AA3	+	513	86.5	46
3	1800	182T	230/460	1LE21211CB114AA3	+	590	89.5	68
5	1800	184T	230/460	1LE21211CB314AA3	+	671	89.5	74
7 ½	1800	213T	230/460	1LE21212AB114AA3	+	939	91.7	130
10	1800	215T	230/460	1LE21212AB214AA3	+	1142	91.7	136
15	1800	254T	230/460	1LE21212BB114AA3	+	1457	92.4	198
20	1800	256T	230/460	1LE21212BB214AA3	+	1755	93.0	229
6 Pole								
1	1200	145T	230/460	1LE21211AC314AA3		533	82.5	45
1 ½	1200	182T	230/460	1LE21211CC114AA3	+	570	87.5	63
2	1200	184T	230/460	1LE21211CC314AA3	+	629	88.5	72
3	1200	213T	230/460	1LE21212AC114AA3	+	809	89.5	104
5	1200	215T	230/460	1LE21212AC214AA3	+	1207	89.5	116
7 ½	1200	254T	230/460	1LE21212BC114AA3	+	1540	91.0	200
10	1200	256T	230/460	1LE21212BC214AA3	+	1814	91.0	196

Voltage code "1-4" - Suitable for 208V

NEMA Premium is a certification mark of the National Electrical Manufacturer's Association

GP100A | Eff: NEMA Premium | 230/460V | Ball Bearing | Long Shaft | C-Face Round Body

Power HP	Speed RPM	NEMA Frame	Voltage	Base Part Number	Stock	List Price	Eff %	Weight (lbs)
4 Pole								
1	1800	143TC	230/460	1LE21211AB214GA3	+	519	85.5	41
1 ½	1800	145TC	230/460	1LE21211AB314GA3	+	561	86.5	47
2	1800	145TC	230/460	1LE21211AB414GA3	+	603	86.5	46
3	1800	182TC	230/460	1LE21211CB114GA3	+	722	89.5	68
5	1800	184TC	230/460	1LE21211CB314GA3	+	803	89.5	74
7 ½	1800	213TC	230/460	1LE21212AB114GA3		1071	91.7	130
10	1800	215TC	230/460	1LE21212AB214GA3		1274	91.7	136
15	1800	254TC	230/460	1LE21212BB114GA3		1637	92.4	198
20	1800	256TC	230/460	1LE21212BB214GA3		1935	93.0	229

GP100A | Eff: NEMA Premium | 575V | Ball Bearing | Long Shaft | Foot Mounted

Power HP	Speed RPM	NEMA Frame	Voltage	Base Part Number	Stock	List Price	Eff %	Weight (lbs)
1	3600	143T	575	1LE21211AA113AA3		429	82.5	29
1 ½	3600	143T	575	1LE21211AA213AA3		440	84.0	35
2	3600	145T	575	1LE21211AA313AA3		511	85.5	38
3	3600	182T	575	1LE21211CA113AA3		570	86.5	57
5	3600	184T	575	1LE21211CA313AA3		741	88.5	67
7 ½	3600	213T	575	1LE21212AA113AA3		969	89.5	100
10	3600	215T	575	1LE21212AA213AA3		1142	90.2	113
15	3600	254T	575	1LE21212BA113AA3		1493	91.0	196
20	3600	256T	575	1LE21212BA213AA3		1848	91.0	231
4 Pole								
1	1800	143T	575	1LE21211AB213AA3		429	85.5	41
1 ½	1800	145T	575	1LE21211AB313AA3		471	86.5	47
2	1800	145T	575	1LE21211AB413AA3		513	86.5	46
3	1800	182T	575	1LE21211CB113AA3	+	590	89.5	68
5	1800	184T	575	1LE21211CB313AA3	+	671	89.5	74
7 ½	1800	213T	575	1LE21212AB113AA3	+	939	91.7	130
10	1800	215T	575	1LE21212AB213AA3		1142	91.7	136
15	1800	254T	575	1LE21212BB113AA3	+	1457	92.4	198
20	1800	256T	575	1LE21212BB213AA3	+	1755	93.0	229
6 Pole								
1	1200	145T	575	1LE21211AC313AA3		533	82.5	45
1 ½	1200	182T	575	1LE21211CC113AA3		570	87.5	63
2	1200	184T	575	1LE21211CC313AA3		629	88.5	72
3	1200	213T	575	1LE21212AC113AA3		809	89.5	104
5	1200	215T	575	1LE21212AC213AA3		1207	89.5	116
7 ½	1200	254T	575	1LE21212BC113AA3		1540	91.0	200
10	1200	256T	575	1LE21212BC213AA3		1814	91.0	196

Voltage code "1-4" - Suitable for 208V

NEMA Premium is a certification mark of the National Electrical Manufacturer's Association

3.2.1.2. GP100

GP100 | Eff: NEMA Premium | Foot Mounted

Power HP	Speed RPM	NEMA Frame	Voltage	Base Part Number	Stock	List Price	Eff %	Weight (lbs)
2 Pole 230/460V Ball Bearing Long Shaft								
1	3600	143T	230/460	1LE22211AA114AA3	+	454	82.5	60
1 ½	3600	143T	230/460	1LE22211AA214AA3	+	466	84	56
2	3600	145T	230/460	1LE22211AA314AA3	+	540	85.5	59
3	3600	182T	230/460	1LE22211CA114AA3	+	602	86.5	87
5	3600	184T	230/460	1LE22211CA314AA3	+	784	88.5	98
7 ½	3600	213T	230/460	1LE22212AA114AA3	+	1025	89.5	148
10	3600	215T	230/460	1LE22212AA214AA3	+	1209	90.2	163
15	3600	254T	230/460	1LE22212BA114AA3	+	1581	91.0	258
20	3600	256T	230/460	1LE22212BA214AA3	+	1955	91.0	293
2 Pole 230/460V Ball Bearing Short Shaft								
25	3600	284TS	230/460	1LE22212DA116AA3	+	2268	91.7	454
30	3600	286TS	230/460	1LE22212DA216AA3	+	2751	91.7	424
40	3600	324TS	230/460	1LE22213BA116AA3	+	3679	93.6	608
50	3600	326TS	230/460	1LE22213BA216AA3	+	4871	93.6	593
60	3600	364TS	230/460	1LE22213DA116AA3	+	5675	93.6	780
75	3600	365TS	230/460	1LE22213DA216AA3	+	7091	94.1	888
2 Pole 460V Ball Bearing Short Shaft								
100	3600	405TS	460	1LE22214BA212AA3	+	10347	94.1	1012
125	3600	444TS	460	1LE22214DA112AA3	+	12831	95.0	1381
150	3600	445TS	460	1LE22214DA212AA3	+	15967	95.0	1542
200	3600	447TS	460	1LE22214DA312AA3	+	22239	95.4	2182
4 Pole 230/460V Ball Bearing Long Shaft								
1	1800	143T	230/460	1LE22211AB214AA3	+	454	85.5	62
1 ½	1800	145T	230/460	1LE22211AB314AA3	+	500	86.5	66
2	1800	145T	230/460	1LE22211AB414AA3	+	542	86.5	66
3	1800	182T	230/460	1LE22211CB114AA3	+	623	89.5	98
5	1800	184T	230/460	1LE22211CB314AA3	+	709	89.5	104
7 ½	1800	213T	230/460	1LE22212AB114AA3	+	994	91.7	171
10	1800	215T	230/460	1LE22212AB214AA3	+	1209	91.7	177
15	1800	254T	230/460	1LE22212BB114AA3	+	1542	92.4	259
20	1800	256T	230/460	1LE22212BB214AA3	+	1857	93.0	292
25	1800	284T	230/460	1LE22212CB116AA3	+	2164	93.6	429
30	1800	286T	230/460	1LE22212CB216AA3	+	2616	93.6	449
40	1800	324T	230/460	1LE22213AB116AA3	+	3522	94.1	633
50	1800	326T	230/460	1LE22213AB216AA3	+	4428	94.5	668
60	1800	364T	230/460	1LE22213CB116AA3	+	5625	95.0	880
75	1800	365T	230/460	1LE22213CB216AA3	+	7096	95.4	950

Voltage code "1-4" - Suitable for 208V

NEMA Premium is a certification mark of the National Electrical Manufacturer's Association

GP100 | Eff: NEMA Premium | Foot Mounted

Power HP	Speed RPM	NEMA Frame	Voltage	Base Part Number	Stock	List Price	Eff %	Weight (lbs)
4 Pole 460V Ball Bearing Long Shaft								
100	1800	405T	460	1LE22214AB212AA3	+	9547	95.4	1107
125	1800	B444T	460	1LE22214EB112AA3	+	11924	95.4	1552
150	1800	B445T	460	1LE22214EB212AA3	+	14359	95.8	1827
200	1800	B447T	460	1LE22214EB312AA3		19230	96.2	2207
4 Pole 460V Ball Bearing Short Shaft								
100	1800	405TS	460	1LE22214BB212AA3	+	9547	95.4	1107
125	1800	444TS	460	1LE22214DB112AA3	+	11924	95.4	1552
150	1800	445TS	460	1LE22214DB212AA3	+	14359	95.8	1637
200	1800	447TS	460	1LE22214DB312AA3	+	19230	96.2	2182
4 Pole 460V Roller Bearing Long Shaft								
125	1800	444T	460	1LE22214CB112AA3	+	12532	95.4	1590
150	1800	445T	460	1LE22214CB212AA3	+	14967	95.8	1865
200	1800	447T	460	1LE22214CB312AA3	+	19838	96.2	2245
6 Pole 230/460V Ball Bearing Long Shaft								
1	1200	145T	230/460	1LE22211AC314AA3	+	563	82.5	64
1 ½	1200	182T	230/460	1LE22211CC114AA3	+	602	87.5	93
2	1200	184T	230/460	1LE22211CC314AA3	+	666	88.5	102
3	1200	213T	230/460	1LE22212AC114AA3	+	857	89.5	144
5	1200	215T	230/460	1LE22212AC214AA3	+	1277	89.5	156
7 ½	1200	254T	230/460	1LE22212BC114AA3	+	1630	91.0	262
10	1200	256T	230/460	1LE22212BC214AA3	+	1918	91.0	259
15	1200	284T	230/460	1LE22212CC116AA3	+	2510	91.7	409
20	1200	286T	230/460	1LE22212CC216AA3	+	2956	91.7	434
25	1200	324T	230/460	1LE22213AC116AA3	+	3565	93.0	633
30	1200	326T	230/460	1LE22213AC216AA3	+	4387	93.0	658
40	1200	364T	230/460	1LE22213CC116AA3	+	6032	94.1	828
50	1200	365T	230/460	1LE22213CC216AA3	+	7088	94.1	863
60	1200	404T	230/460	1LE22214AC116AA3	+	7354	94.5	1047
75	1200	405T	230/460	1LE22214AC216AA3		8615	94.5	1117
6 Pole 460V Ball Bearing Long Shaft								
100	1200	B444T	460	1LE22214EC112AA3		12821	95.0	1664
125	1200	B445T	460	1LE22214EC212AA3		14942	95.0	1664
150	1200	B447T	460	1LE22214EC312AA3		17317	95.8	1922
200	1200	B449T	460	1LE22214EC512AA3		23340	95.8	2263
6 Pole 460V Ball Bearing Short Shaft								
100	1200	444TS	460	1LE22214DC112AA3		12821	95.0	1467
125	1200	445TS	460	1LE22214DC212AA3		14942	95.0	1647
150	1200	447TS	460	1LE22214DC312AA3		17317	95.8	1897
200	1200	449TS	460	1LE22214DC512AA3		23340	95.8	2240

GP100 | Eff: NEMA Premium | Foot Mounted

Power HP	Speed RPM	NEMA Frame	Voltage	Base Part Number	Stock	List Price	Eff %	Weight (lbs)
6 Pole 460V Roller Bearing Long Shaft								
100	1200	444T	460	1LE22214CC112AA3		13429	95.0	1531
125	1200	445T	460	1LE22214CC212AA3	+	15550	95.0	1702
150	1200	447T	460	1LE22214CC312AA3		17925	95.8	1960
200	1200	449T	460	1LE22214CC512AA3		23948	95.8	2301
8 Pole 230/460V Ball Bearing Long Shaft								
1	900	182T	230/460	1LE22211CD114AA3	+	682	81.5	86
1 ½	900	184T	230/460	1LE22211CD314AA3		741	82.5	99
2	900	213T	230/460	1LE22212AD114AA3	+	852	84.0	123
3	900	215T	230/460	1LE22212AD214AA3	+	1222	85.5	138
5	900	254T	230/460	1LE22212BD114AA3	+	1774	86.5	218
7 ½	900	256T	230/460	1LE22212BD214AA3	+	1787	87.5	250
10	900	284T	230/460	1LE22212CD116AA3		2569	90.2	414
15	900	286T	230/460	1LE22212CD216AA3		3051	91.0	459
20	900	324T	230/460	1LE22213AD116AA3		3664	91.0	616
25	900	326T	230/460	1LE22213AD216AA3		4242	91.0	663
30	900	364T	230/460	1LE22213CD116AA3		5449	91.7	854
40	900	365T	230/460	1LE22213CD216AA3		6436	91.7	950

Voltage code "1-4" - Suitable for 208V

NEMA Premium is a certification mark of the National Electrical Manufacturer's Association

GP100 | Eff: NEMA Premium | C-Face Round Body

Power HP	Speed RPM	NEMA Frame	Voltage	Base Part Number	Stock	List Price	Eff %	Weight (lbs)
2 Pole 230/460V Ball Bearing Long Shaft								
1	3600	143TC	230/460	1LE22211AA114GA3		544	82.5	60
1 ½	3600	143TC	230/460	1LE22211AA214GA3	+	556	84.0	56
2	3600	145TC	230/460	1LE22211AA314GA3	+	630	85.5	59
3	3600	182TC	230/460	1LE22211CA114GA3	+	734	86.5	87
5	3600	184TC	230/460	1LE22211CA314GA3	+	916	88.5	98
7 ½	3600	213TC	230/460	1LE22212AA114GA3	+	1157	89.5	148
10	3600	215TC	230/460	1LE22212AA214GA3	+	1341	90.2	163
15	3600	254TC	230/460	1LE22212BA114GA3	+	1761	91.0	258
20	3600	256TC	230/460	1LE22212BA214GA3		2135	91.0	293
4 Pole 230/460V Ball Bearing Long Shaft								
1	1800	143TC	230/460	1LE22211AB214GA3	+	544	85.5	62
1 ½	1800	145TC	230/460	1LE22211AB314GA3	+	590	86.5	66
2	1800	145TC	230/460	1LE22211AB414GA3	+	632	86.5	66
3	1800	182TC	230/460	1LE22211CB114GA3	+	755	89.5	98
5	1800	184TC	230/460	1LE22211CB314GA3	+	841	89.5	104
7 ½	1800	213TC	230/460	1LE22212AB114GA3	+	1126	91.7	171
10	1800	215TC	230/460	1LE22212AB214GA3	+	1341	91.7	177
15	1800	254TC	230/460	1LE22212BB114GA3	+	1722	92.4	259
20	1800	256TC	230/460	1LE22212BB214GA3		2037	93.0	292
6 Pole 230/460V Ball Bearing Long Shaft								
1	1200	145TC	230/460	1LE22211AC314GA3		653	82.5	64
1 ½	1200	182TC	230/460	1LE22211CC114GA3		734	87.5	93
2	1200	184TC	230/460	1LE22211CC314GA3		798	88.5	102
3	1200	213TC	230/460	1LE22212AC114GA3		989	89.5	144
5	1200	215TC	230/460	1LE22212AC214GA3		1409	89.5	156
7 ½	1200	254TC	230/460	1LE22212BC114GA3		1810	91.0	262
10	1200	256TC	230/460	1LE22212BC214GA3		2098	91.0	259
8 Pole 230/460V Ball Bearing Long Shaft								
1	900	182TC	230/460	1LE22211CD114GA3	+	814	81.5	86
1 ½	900	184TC	230/460	1LE22211CD314GA3		873	82.5	99
2	900	213TC	230/460	1LE22212AD114GA3		984	84.0	123
3	900	215TC	230/460	1LE22212AD214GA3		1354	85.5	138
5	900	254TC	230/460	1LE22212BD114GA3		1954	86.5	218
7 ½	900	256TC	230/460	1LE22212BD214GA3		1967	87.5	250

Voltage code "1-4" - Suitable for 208V

NEMA Premium is a certification mark of the National Electrical Manufacturer's Association

GP100 | Eff: NEMA Premium | C-Face with Feet

Power HP	Speed RPM	NEMA Frame	Voltage	Base Part Number	Stock	List Price	Eff %	Weight (lbs)
2 Pole 230/460V Ball Bearing Long Shaft								
1	3600	143TC	230/460	1LE22211AA114EA3	Mod	560	82.5	60
1 ½	3600	145TC	230/460	1LE22211AA214EA3	Mod	572	84.0	56
2	3600	145TC	230/460	1LE22211AA314EA3	+	646	85.5	59
3	3600	182TC	230/460	1LE22211CA114EA3	Mod	756	86.5	87
5	3600	184TC	230/460	1LE22211CA314EA3	+	938	88.5	98
7 ½	3600	213TC	230/460	1LE22212AA114EA3	Mod	1189	89.5	148
10	3600	215TC	230/460	1LE22212AA214EA3	+	1373	90.2	163
15	3600	254TC	230/460	1LE22212BA114EA3	+	1810	91.0	258
20	3600	256TC	230/460	1LE22212BA214EA3	+	2184	91.0	293
4 Pole 230/460V Ball Bearing Long Shaft								
1	1800	143TC	230/460	1LE22211AB214EA3	+	560	85.5	62
1 ½	1800	145TC	230/460	1LE22211AB314EA3	+	606	86.5	66
2	1800	145TC	230/460	1LE22211AB414EA3	+	648	86.5	66
3	1800	182TC	230/460	1LE22211CB114EA3	+	777	89.5	98
5	1800	184TC	230/460	1LE22211CB314EA3	+	863	89.5	104
7 ½	1800	213TC	230/460	1LE22212AB114EA3	+	1158	91.7	171
10	1800	215TC	230/460	1LE22212AB214EA3	+	1373	91.7	177
15	1800	254TC	230/460	1LE22212BB114EA3	+	1771	92.4	259
20	1800	256TC	230/460	1LE22212BB214EA3	+	2086	93.0	292

Voltage code "1-4" - Suitable for 208V

NEMA Premium is a certification mark of the National Electrical Manufacturer's Association

GP100 | Eff: NEMA Premium | Foot Mounted | 575V

Power HP	Speed RPM	NEMA Frame	Voltage	Base Part Number	Stock	List Price	Eff %	Weight (lbs)
2 Pole 575V Ball Bearing Long Shaft								
1	3600	143T	575	1LE22211AA113AA3		454	82.5	60
1 ½	3600	143T	575	1LE22211AA213AA3		466	84.0	56
2	3600	145T	575	1LE22211AA313AA3		540	85.5	59
3	3600	182T	575	1LE22211CA113AA3	+	602	86.5	87
5	3600	184T	575	1LE22211CA313AA3	+	784	88.5	98
7 ½	3600	213T	575	1LE22212AA113AA3	+	1025	89.5	148
10	3600	215T	575	1LE22212AA213AA3	+	1209	90.2	163
15	3600	254T	575	1LE22212BA113AA3	+	1581	91.0	258
20	3600	256T	575	1LE22212BA213AA3		1955	91.0	293
2 Pole 575V Ball Bearing Short Shaft								
25	3600	284TS	575	1LE22212DA113AA3		2268	91.7	454
30	3600	286TS	575	1LE22212DA213AA3		2751	91.7	424
40	3600	324TS	575	1LE22213BA113AA3		3679	93.6	608
50	3600	326TS	575	1LE22213BA213AA3		4871	93.6	593
60	3600	364TS	575	1LE22213DA113AA3		5675	93.6	780
75	3600	365TS	575	1LE22213DA213AA3		7091	94.1	888
100	3600	405TS	575	1LE22214BA213AA3		10347	94.1	1012
125	3600	444TS	575	1LE22214DA113AA3		12831	95.0	1381
150	3600	445TS	575	1LE22214DA213AA3		15967	95.0	1542
200	3600	447TS	575	1LE22214DA313AA3		22239	95.4	2182
4 Pole 575V Ball Bearing Long Shaft								
1	1800	143T	575	1LE22211AB213AA3	+	454	85.5	62
1 ½	1800	145T	575	1LE22211AB313AA3	+	500	86.5	66
2	1800	145T	575	1LE22211AB413AA3		542	86.5	66
3	1800	182T	575	1LE22211CB113AA3	+	623	89.5	98
5	1800	184T	575	1LE22211CB313AA3		709	89.5	104
7 ½	1800	213T	575	1LE22212AB113AA3	+	994	91.7	171
10	1800	215T	575	1LE22212AB213AA3	+	1209	91.7	177
15	1800	254T	575	1LE22212BB113AA3	+	1542	92.4	259
20	1800	256T	575	1LE22212BB213AA3	+	1857	93.0	292
25	1800	284T	575	1LE22212CB113AA3	+	2164	93.6	429
30	1800	286T	575	1LE22212CB213AA3	+	2616	93.6	449
40	1800	324T	575	1LE22213AB113AA3	+	3,522	94.1	633
50	1800	326T	575	1LE22213AB213AA3		4428	94.5	668
60	1800	364T	575	1LE22213CB113AA3	+	5625	95.0	880
75	1800	365T	575	1LE22213CB213AA3	+	7096	95.4	950
100	1800	405T	575	1LE22214AB213AA3	+	9547	95.4	1107
125	1800	B444T	575	1LE22214EB113AA3		11924	95.4	1552
150	1800	B445T	575	1LE22214EB213AA3		14359	95.8	1827
200	1800	B447T	575	1LE22214EB313AA3		19230	96.2	2207
4 Pole 575V Ball Bearing Short Shaft								
100	1800	405TS	575	1LE22214BB213AA3		9547	95.4	1107
125	1800	444TS	575	1LE22214DB113AA3		11924	95.4	1552
150	1800	445TS	575	1LE22214DB213AA3		14359	95.8	1637
200	1800	447TS	575	1LE22214DB313AA3		19230	96.2	2182

GP100 | Eff: NEMA Premium | Foot Mounted | 575V

Power HP	Speed RPM	NEMA Frame	Voltage	Base Part Number	Stock	List Price	Eff %	Weight (lbs)
4 Pole 575V Roller Bearing Long Shaft								
125	1800	444T	575	1LE22214CB113AA3		12532	95.4	1590
150	1800	445T	575	1LE22214CB213AA3		14967	95.8	1865
200	1800	447T	575	1LE22214CB313AA3		19838	96.2	2245
6 Pole 575V Ball Bearing Long Shaft								
1	1200	145T	575	1LE22211AC313AA3		563	82.5	64
1 ½	1200	182T	575	1LE22211CC113AA3		602	87.5	93
2	1200	184T	575	1LE22211CC313AA3		666	88.5	102
3	1200	213T	575	1LE22212AC113AA3		857	89.5	144
5	1200	215T	575	1LE22212AC213AA3		1277	89.5	156
7 ½	1200	254T	575	1LE22212BC113AA3		1630	91.0	262
10	1200	256T	575	1LE22212BC213AA3		1918	91.0	259
15	1200	284T	575	1LE22212CC113AA3		2510	91.7	409
20	1200	286T	575	1LE22212CC213AA3		2956	91.7	434
25	1200	324T	575	1LE22213AC113AA3		3565	93.0	633
30	1200	326T	575	1LE22213AC213AA3		4387	93.0	658
40	1200	364T	575	1LE22213CC113AA3		6032	94.1	828
50	1200	365T	575	1LE22213CC213AA3		7088	94.1	863
60	1200	404T	575	1LE22214AC113AA3		7354	94.5	1047
75	1200	405T	575	1LE22214AC213AA3		8615	94.5	1117
100	1200	B444T	575	1LE22214EC113AA3		12821	95.0	1664
125	1200	B445T	575	1LE22214EC213AA3		14942	95.0	1664
150	1200	B447T	575	1LE22214EC313AA3		17317	95.8	1922
200	1200	B449T	575	1LE22214EC513AA3		23340	95.8	2263
6 Pole 575V Ball Bearing Short Shaft								
100	1200	444TS	575	1LE22214DC113AA3		12821	95.0	1467
125	1200	445TS	575	1LE22214DC213AA3		14942	95.0	1647
150	1200	447TS	575	1LE22214DC313AA3		17317	95.8	1897
200	1200	449TS	575	1LE22214DC513AA3		23340	95.8	2240
6 Pole 575V Roller Bearing Long Shaft								
100	1200	444T	575	1LE22214CC113AA3		13429	95.0	1531
125	1200	445T	575	1LE22214CC213AA3		15550	95.0	1702
150	1200	447T	575	1LE22214CC313AA3		17925	95.8	1960
200	1200	449T	575	1LE22214CC513AA3		23948	95.8	2301

NEMA Premium is a certification mark of the National Electrical Manufacturer's Association

GP100 | Eff: NEMA Premium | Foot Mounted | 575V

Power HP	Speed RPM	NEMA Frame	Voltage	Base Part Number	Stock	List Price	Eff %	Weight (lbs)
8 Pole 575V Ball Bearing Long Shaft								
1	900	182T	575	1LE22211CD113AA3		682	81.5	86
1 ½	900	184T	575	1LE22211CD313AA3		741	82.5	99
2	900	213T	575	1LE22212AD113AA3		852	84.0	123
3	900	215T	575	1LE22212AD213AA3		1222	85.5	138
5	900	254T	575	1LE22212BD113AA3		1774	86.5	218
7 ½	900	256T	575	1LE22212BD213AA3		1787	87.5	250
10	900	284T	575	1LE22212CD113AA3		2569	90.2	414
15	900	286T	575	1LE22212CD213AA3		3051	91.0	459
20	900	324T	575	1LE22213AD113AA3		3664	91.0	616
25	900	326T	575	1LE22213AD213AA3		4242	91.0	663
30	900	364T	575	1LE22213CD113AA3		5449	91.7	854
40	900	365T	575	1LE22213CD213AA3		6436	91.7	950

NEMA Premium is a certification mark of the National Electrical Manufacturer's Association

3.2.2. Severe Duty Low Voltage NEMA Motors

Introduction

ABB Severe Duty low voltage NEMA motors are designed and built to operate under harsh environments in the industry, including but not limited to petrochemical, pulp and paper mills and waste-water treatment. Fans, compressors, pumps, and conveyors are some of the many applications. These motors are design to meet or exceed the NEMA Premium® efficiency (MG1 Table 12.12) as well as the most stringent industry standards IEEE 841. A wide selection of options, among them IP56 ingress protection, encoders, brakes, and blower, provide higher flexibility and reliability to a diversity of operating conditions. The construction of these motors is backed by its 3-to-5-year warranty for SD100 and 5-year warranty for SD100 IEEE841 and SD661.

Performance Specification



		SD100	SD100 IEEE841	SD661
HP Range	3600 RPM	1-400 HP		–
	1800 RPM	1-400 HP		5-75 HP
	1200 RPM	1-300 HP		7 ½-50 HP
	900 RPM	1-250 HP		–
Frame Size	140T - 500	140T-S449		180T-360T
Standard Voltage (3~ 60 Hz)	230V/460V (Suitable for 208V)	FS 140-250	–	–
	230V/460V	Up to 75 HP	–	–
	460V	1-400 HP	1-400 HP	5-75 HP
	575V	1-400 HP	1-400 HP	5-75 HP
Efficiency	NEMA Premium® (MG1-Table 12.12)	1 - 400 HP		5-75 HP
Service Factor	1.15 @ 40°C	FS140-S449		FS 180-360
Insulation	Non-Hygroscopic	Class F		
Temperature Rise	Class B	@ 1.0SF		
	Class F	@ 1.15SF		
Conduit Box (Oversized)	Oversized	Cast Iron		
Fan Cover		Cast Iron		
Cooling Fan	Bi-Directional	Polypropylene		
Rotor	Die Cast Aluminum	FS 140-S449		FS 180-360
Ingress Protection	NEMA	IP55	IP55	IP56
Hazardous Location	Gas	CL 1, Div 2 Gr. A, B, C or D Temp Code T3 ²		
	Dust ³	CL 2, Div 2 Gr. F & G Temp Code T3C		
Inverter Duty	Variable Torque 20:1	FS 140-S449		FS 180-360
	Constant Torque CT 4:1	FS 140-S449		FS 180-360
	Constant Torque CT 20:1	4 Pole FS140-360		4 pole FS 180-360
	Constant Torque CT 10:1 ⁴	4 Pole FS400-445		–
	Constant Torque CT 6:1 ⁴	4 Pole FS447		–

2. FS S449: Temperature Code T2D

3. Standard on frames 280-400. As option (M25) for other frames

4. As option (M05 - VFD Fan)

Frame and end shields

The Severe Duty SD100, SD100IEEE841 and SD661, feature cast iron frame, end shields, and an easy-to-access, diagonally-split, oversize terminal box; the terminal box is provided with a neoprene gasket and includes a heavy-duty ground lug and non-wicking clearly and permanently marked leads. These characteristics, its high strength zinc-plated hardware, epoxy paint and stainless-steel nameplate provide exceptional structural integrity and resistance to rust and corrosion, making them suitable for severe duty applications in harsh environments.

Rotor and stator windings

A unique offset rotor bar design provides improved efficiency, while larger bars and end rings reduce resistance for lower rotor losses. Each die cast aluminum rotor assembly is dynamically balanced for extended bearing life and includes a high-strength carbon steel (C1045) shaft for maximum rotor performance.

The stator is manufactured with premium electrical C5 grade steel lamination and copper electrical magnet wire that furthers the reduction in losses.

Insulation

The proprietary Class F non-hygroscopic insulation system, NEMA Class B temperature rise, provides an extra margin of thermal life. The varnish system application ensures maximum wire penetration to provide protection from moisture, corrosion, and electrical shock. This insulation system meets or exceeds NEMA MG1 2014 Part 31 making the motors suitable for variable speed drives in constant torque (4:1) and variable torque (20:1). All windings are tested for CIV.

Cooling system

A non-sparking, bi-directional fan is locked and keyed to the shaft. Its low-inertia design reduces windage losses, improves airflow, reduces noise, and provides dependable cooling. Cast Iron fan covers are provided for all frames sizes.

Bearings

Single shielded bearings are used for better bearing protection against contaminants.

3.2.2.1. SD100



SD100 | Eff: NEMA Premium | Foot Mounted

Power HP	Speed RPM	NEMA Frame	Voltage	Base Part Number	Stock	List Price	Eff %	Weight (lbs)
2 Pole 230/460V Ball Bearing Long Shaft								
1	3600	143T	230/460	1LE23211AA114AA3	+	574	85.5	62
1 ½	3600	143T	230/460	1LE23211AA214AA3	+	574	86.5	66
2	3600	145T	230/460	1LE23211AA314AA3	+	686	86.5	66
3	3600	182T	230/460	1LE23211CA114AA3	+	771	89.5	98
5	3600	184T	230/460	1LE23211CA314AA3	+	955	89.5	104
7 ½	3600	213T	230/460	1LE23212AA114AA3	+	1121	91.7	171
10	3600	215T	230/460	1LE23212AA214AA3	+	1349	91.7	177
15	3600	254T	230/460	1LE23212BA114AA3	+	1853	92.4	259
20	3600	256T	230/460	1LE23212BA214AA3	+	2294	93.0	292
2 Pole 460V Ball Bearing Short Shaft								
25	3600	284TS	460	1LE23212DA112AA3	+	2702	91.7	415
30	3600	286TS	460	1LE23212DA212AA3	+	3155	91.7	430
40	3600	324TS	460	1LE23213BA112AA3	+	4163	93.6	575
50	3600	326TS	460	1LE23213BA212AA3	+	5384	93.6	610
60	3600	364TS	460	1LE23213DA112AA3	+	7083	93.6	717
75	3600	365TS	460	1LE23213DA212AA3	+	8894	94.1	815
100	3600	405TS	460	1LE23214BA212AA3	+	11919	94.1	1100
125	3600	444TS	460	1LE23214DA112AA3	See SD200	15574	95.0	1454
150	3600	445TS	460	1LE23214DA212AA3	See SD200	18709	95.0	1615
200	3600	447TS	460	1LE23214DA312AA3	See SD200	23666	95.4	1890
250	3600	449TS	460	1LE23214DA512AA3	See SD200	29849	95.8	2272
300	3600	449TS	460	1LE23214DA612AA3	See SD200	40858	95.8	2200
350	3600	S449SS	460	1LE23214GA112AA3	See SD200	41992	95.8	2890
400	3600	S449SS	460	1LE23214GA312AA3	See SD200	52365	95.8	3065

Voltage code "1-4" - Suitable for 208V

2 Pole S449SS CW rotation facing NDE as standard

SD100 | Eff: NEMA Premium | Foot Mounted

Power HP	Speed RPM	NEMA Frame	Voltage	Base Part Number	Stock	List Price	Eff %	Weight (lbs)
4 Pole 230/460V Ball Bearing Long Shaft								
1	1800	143T	230/460	1LE23211AB214AA3	+	537	85.5	76
1 ½	1800	145T	230/460	1LE23211AB314AA3	+	595	86.5	80
2	1800	145T	230/460	1LE23211AB414AA3	+	655	86.5	80
3	1800	182T	230/460	1LE23211CB114AA3	+	726	89.5	118
5	1800	184T	230/460	1LE23211CB314AA3	+	848	89.5	124
7 ½	1800	213T	230/460	1LE23212AB114AA3	+	1117	91.7	191
10	1800	215T	230/460	1LE23212AB214AA3	+	1387	91.7	197
15	1800	254T	230/460	1LE23212BB114AA3	+	1826	92.4	289
20	1800	256T	230/460	1LE23212BB214AA3	+	2274	93.0	322
25	1800	284T	230/460	1LE23212CB116AA3	+	2587	93.6	445
30	1800	286T	230/460	1LE23212CB216AA3	+	3010	93.6	465
40	1800	324T	230/460	1LE23213AB116AA3	+	3998	94.1	666
50	1800	326T	230/460	1LE23213AB216AA3	+	4910	94.5	700
60	1800	364T	230/460	1LE23213CB116AA3	+	7043	95.0	930
75	1800	365T	230/460	1LE23213CB216AA3	+	8928	95.4	1000
4 Pole 460V Ball Bearing Long Shaft								
25	1800	284T	460	1LE23212CB112AA3	+	2587	93.6	445
30	1800	286T	460	1LE23212CB212AA3	+	3010	93.6	465
40	1800	324T	460	1LE23213AB112AA3	+	3998	94.1	666
50	1800	326T	460	1LE23213AB212AA3	+	4910	94.5	700
60	1800	364T	460	1LE23213CB112AA3	+	7043	95.0	930
75	1800	365T	460	1LE23213CB212AA3	+	8928	95.4	1000
100	1800	405T	460	1LE23214AB212AA3	+	11032	95.4	1160
125	1800	B444T	460	1LE23214EB112AA3	See SD200	14518	95.4	1600
150	1800	B445T	460	1LE23214EB212AA3	See SD200	16878	95.8	1710
200	1800	B447T	460	1LE23214EB312AA3	See SD200	20529	96.2	2035
250	1800	B449T	460	1LE23214EB512AA3	See SD200	25755	96.2	2425
300	1800	B449T	460	1LE23214EB612AA3	See SD200	30036	96.2	3130
4 Pole 460V Ball Bearing Short Shaft								
25	1800	284TS	460	1LE23212DB112AA3	+	2587	93.6	445
30	1800	286TS	460	1LE23212DB212AA3	+	3010	93.6	465
40	1800	324TS	460	1LE23213BB112AA3	+	3998	94.1	666
50	1800	326TS	460	1LE23213BB212AA3	+	4910	94.5	700
60	1800	364TS	460	1LE23213DB112AA3	+	7043	95.0	930
75	1800	365TS	460	1LE23213DB212AA3	+	8928	95.4	1000
100	1800	405TS	460	1LE23214BB212AA3	+	11032	95.4	1160
125	1800	444TS	460	1LE23214DB112AA3	See SD200	14518	95.4	1600
150	1800	445TS	460	1LE23214DB212AA3	See SD200	16878	95.8	1710
200	1800	447TS	460	1LE23214DB312AA3	See SD200	20529	96.2	2035
250	1800	449TS	460	1LE23214DB512AA3	See SD200	25755	96.2	2425
300	1800	449TS	460	1LE23214DB612AA3	See SD200	30036	96.2	3130
350	1800	S449SS	460	1LE23214GB212AA3	See SD200	39003	96.2	3190
400	1800	S449SS	460	1LE23214GB312AA3	See SD200	48649	96.2	3240

Voltage code "1-4" - Suitable for 208V

250HP and 300HP 4 pole and 6 pole - NEMA Design A

NEMA Premium is a certification mark of the National Electrical Manufacturer's Association

SD100 | Eff: NEMA Premium | Foot Mounted

Power HP	Speed RPM	NEMA Frame	Voltage	Base Part Number	Stock	List Price	Eff %	Weight (lbs)
4 Pole 460V Roller Bearing Long Shaft								
125	1800	444T	460	1LE23214CB112AA3	See SD200	15126	95.4	1600
150	1800	445T	460	1LE23214CB212AA3	See SD200	17486	95.8	1710
200	1800	447T	460	1LE23214CB312AA3	See SD200	21137	96.2	2035
250	1800	449T	460	1LE23214CB512AA3	See SD200	26363	96.2	2425
300	1800	449T	460	1LE23214CB612AA3	See SD200	30644	96.2	3130
350	1800	S449LS	460	1LE23214FB212AA3	See SD200	39611	96.2	3190
400	1800	S449LS	460	1LE23214FB312AA3	See SD200	49257	96.2	3240
6 Pole 230/460V Ball Bearing Long Shaft								
1	1200	145T	230/460	1LE23211AC314AA3	+	663	82.5	77
1.5	1200	182T	230/460	1LE23211CC114AA3	+	747	87.5	113
2	1200	184T	230/460	1LE23211CC314AA3	+	835	88.5	122
3	1200	213T	230/460	1LE23212AC114AA3	+	1017	89.5	164
5	1200	215T	230/460	1LE23212AC214AA3	+	1433	89.5	176
7.5	1200	254T	230/460	1LE23212BC114AA3	+	1852	91.0	292
10	1200	256T	230/460	1LE23212BC214AA3	+	2328	91.0	288
15	1200	284T	230/460	1LE23212CC116AA3	+	2954	91.7	400
20	1200	286T	230/460	1LE23212CC216AA3	+	3598	91.7	465
6 Pole 460V Ball Bearing Long Shaft								
25	1200	324T	460	1LE23213AC112AA3	+	4235	93.0	640
30	1200	326T	460	1LE23213AC212AA3	+	5017	93.0	675
40	1200	364T	460	1LE23213CC112AA3	+	6803	94.1	863
50	1200	365T	460	1LE23213CC212AA3	+	7810	94.1	900
60	1200	404T	460	1LE23214AC112AA3	+	9150	94.5	1100
75	1200	405T	460	1LE23214AC212AA3	+	10772	94.5	1150
100	1200	B444T	460	1LE23214EC112AA3	See SD200	14724	95.0	1545
125	1200	B445T	460	1LE23214EC212AA3	See SD200	18079	95.0	1720
150	1200	B447T	460	1LE23214EC312AA3	See SD200	20228	95.8	1995
200	1200	B449T	460	1LE23214EC512AA3	See SD200	24761	95.8	2425
250	1200	B449T	460	1LE23214EC612AA3	See SD200	26944	95.8	2390
6 Pole 460V Ball Bearing Short Shaft								
100	1200	444TS	460	1LE23214DC112AA3	See SD200	14724	95.0	1545
125	1200	445TS	460	1LE23214DC212AA3	See SD200	18079	95.0	1720
150	1200	447TS	460	1LE23214DC312AA3	See SD200	20228	95.8	1995
200	1200	449TS	460	1LE23214DC512AA3	See SD200	24761	95.8	2425
250	1200	449TS	460	1LE23214DC612AA3	See SD200	26944	95.8	2390
6 Pole 460V Ball Bearing Long Shaft								
100	1200	444T	460	1LE23214CC112AA3	See SD200	15332	95.0	1545
125	1200	445T	460	1LE23214CC212AA3	See SD200	18687	95.0	1720
150	1200	447T	460	1LE23214CC312AA3	See SD200	20836	95.8	1995
200	1200	449T	460	1LE23214CC512AA3	See SD200	25369	95.8	2425
250	1200	449T	460	1LE23214CC612AA3	See SD200	27552	95.8	2390
300	1200	S449LS	460	1LE23214FC112AA3	See SD200	48251	95.8	3240

Voltage code "1-4" - Suitable for 208V

250HP and 300HP 4 pole and 6 pole - NEMA Design A

NEMA Premium is a certification mark of the National Electrical Manufacturer's Association

SD100 | Eff: NEMA Premium | Foot Mounted

Power HP	Speed RPM	NEMA Frame	Voltage	Base Part Number	Stock	List Price	Eff %	Weight (lbs)
8 Pole 230/460V Ball Bearing Long Shaft								
1	900	182T	230/460	1LE23211CD114AA3	+	900	81.5	106
1 ½	900	184T	230/460	1LE23211CD314AA3	+	1014	82.5	119
2	900	213T	230/460	1LE23212AD114AA3	+	1175	84.0	143
3	900	215T	230/460	1LE23212AD214AA3	+	1621	85.5	158
5	900	254T	230/460	1LE23212BD114AA3	+	2279	86.5	247
7 ½	900	256T	230/460	1LE23212BD214AA3	+	2630	87.5	279
10	900	284T	230/460	1LE23212CD116AA3	+	3511	91.0	375
15	900	286T	230/460	1LE23212CD216AA3	+	4569	91.0	430
20	900	324T	230/460	1LE23213AD116AA3	+	5585	91.0	567
8 Pole 460V Ball Bearing Long Shaft								
25	900	326T	460	1LE23213AD212AA3	+	6487	90.2	600
30	900	364T	460	1LE23213CD112AA3	+	7676	91.0	800
40	900	365T	460	1LE23213CD212AA3	+	9283	91.7	875
50	900	404T	460	1LE23214AD112AA3	+	11091	92.4	1135
60	900	405T	460	1LE23214AD212AA3	+	12668	92.4	1300
75	900	B444T	460	1LE23214ED112AA3	See SD200	16694	93.6	1625
100	900	B445T	460	1LE23214ED212AA3	See SD200	20641	94.1	1900
125	900	B447T	460	1LE23214ED312AA3	See SD200	21897	94.1	2280
150	900	B447T	460	1LE23214ED412AA3	See SD200	27964	94.1	2280
8 Pole 460V Roller Bearing Long Shaft								
75	900	444T	460	1LE23214CD112AA3	See SD200	17302	93.6	1625
100	900	445T	460	1LE23214CD212AA3	See SD200	21249	94.1	1900
125	900	447T	460	1LE23214CD312AA3	See SD200	22505	94.1	2280
150	900	447T	460	1LE23214CD412AA3	See SD200	28572	94.1	2280
200	900	S449LS	460	1LE23214FD112AA3	See SD200	34838	94.5	3200
250	900	S449LS	460	1LE23214FD212AA3	See SD200	41045	94.5	3316

Voltage code "1-4" - Suitable for 208V

NEMA Premium is a certification mark of the National Electrical Manufacturer's Association

SD100 | Eff: NEMA Premium | C-Face Round Body

Power HP	Speed RPM	NEMA Frame	Voltage	Base Part Number	Stock	List Price	Eff %	Weight (lbs)
2 Pole 230/460V Ball Bearing Long Shaft								
1	3600	143TC	230/460	1LE23211AA114GA3	+	664	82.5	75
1.5	3600	143TC	230/460	1LE23211AA214GA3	+	664	84.0	70
2	3600	145TC	230/460	1LE23211AA314GA3	+	776	85.5	72
3	3600	182TC	230/460	1LE23211CA114GA3	+	903	86.5	107
5	3600	184TC	230/460	1LE23211CA314GA3	+	1087	88.5	118
7.5	3600	213TC	230/460	1LE23212AA114GA3	+	1253	89.5	160
10	3600	215TC	230/460	1LE23212AA214GA3	+	1481	90.2	174
15	3600	254TC	230/460	1LE23212BA114GA3	+	2033	91.0	287
20	3600	256TC	230/460	1LE23212BA214GA3	+	2474	91.0	323
4 Pole 230/460V Ball Bearing Long Shaft								
1	1800	143TC	230/460	1LE23211AB214GA3	+	627	85.5	76
1.5	1800	145TC	230/460	1LE23211AB314GA3	+	685	86.5	80
2	1800	145TC	230/460	1LE23211AB414GA3	+	745	86.5	80
3	1800	182TC	230/460	1LE23211CB114GA3	+	858	89.5	118
5	1800	184TC	230/460	1LE23211CB314GA3	+	980	89.5	124
7.5	1800	213TC	230/460	1LE23212AB114GA3	+	1249	91.7	191
10	1800	215TC	230/460	1LE23212AB214GA3	+	1519	91.7	197
15	1800	254TC	230/460	1LE23212BB114GA3	+	2006	92.4	289
20	1800	256TC	230/460	1LE23212BB214GA3	+	2454	93.0	322
6 Pole 230/460V Ball Bearing Long Shaft								
1	1200	145TC	230/460	1LE23211AC314GA3	+	753	82.5	77
1.5	1200	182TC	230/460	1LE23211CC114GA3	+	879	87.5	113
2	1200	184TC	230/460	1LE23211CC314GA3	+	967	88.5	122
3	1200	213TC	230/460	1LE23212AC114GA3	+	1149	89.5	164
5	1200	215TC	230/460	1LE23212AC214GA3	+	1565	89.5	176
7.5	1200	254TC	230/460	1LE23212BC114GA3	+	2032	91.0	292
10	1200	256TC	230/460	1LE23212BC214GA3	+	2508	91.0	288
8 Pole 230/460V Ball Bearing Long Shaft								
1	900	182TC	230/460	1LE23211CD114GA3	+	1032	81.5	106
1.5	900	184TC	230/460	1LE23211CD314GA3	+	1146	82.5	119
2	900	213TC	230/460	1LE23212AD114GA3	+	1307	84.0	143
3	900	215TC	230/460	1LE23212AD214GA3	+	1753	85.5	158
5	900	254TC	230/460	1LE23212BD114GA3	+	2459	86.5	247
7.5	900	256TC	230/460	1LE23212BD214GA3	+	2810	87.5	279

Voltage code "1-4" - Suitable for 208V

NEMA Premium is a certification mark of the National Electrical Manufacturer's Association

SD100 | Eff: NEMA Premium | Foot Mounted | 575V

Power HP	Speed RPM	NEMA Frame	Voltage	Base Part Number	Stock	List Price	Eff %	Weight (lbs)
2 Pole 575V Ball Bearing Long Shaft								
1	3600	143T	575	1LE23211AA113AA3		574	85.5	62
1 ½	3600	143T	575	1LE23211AA213AA3		574	86.5	66
2	3600	145T	575	1LE23211AA313AA3		686	86.5	66
3	3600	182T	575	1LE23211CA113AA3		771	89.5	98
5	3600	184T	575	1LE23211CA313AA3		955	89.5	104
7 ½	3600	213T	575	1LE23212AA113AA3		1121	91.7	171
10	3600	215T	575	1LE23212AA213AA3		1349	91.7	177
15	3600	254T	575	1LE23212BA113AA3		1853	92.4	259
20	3600	256T	575	1LE23212BA213AA3		2294	93.0	292
25	3600	284TS	575	1LE23212DA113AA3		2702	91.7	415
30	3600	286TS	575	1LE23212DA213AA3		3155	91.7	430
40	3600	324TS	575	1LE23213BA113AA3		4163	93.6	575
50	3600	326TS	575	1LE23213BA213AA3		5384	93.6	610
60	3600	364TS	575	1LE23213DA113AA3		7083	93.6	717
75	3600	365TS	575	1LE23213DA213AA3		8894	94.1	815
100	3600	405TS	575	1LE23214BA213AA3		11919	94.1	1100
125	3600	444TS	575	1LE23214DA113AA3	See SD200	15574	95.0	1454
150	3600	445TS	575	1LE23214DA213AA3	See SD200	18709	95.0	1615
200	3600	447TS	575	1LE23214DA313AA3	See SD200	23666	95.4	1890
250	3600	449TS	575	1LE23214DA513AA3	See SD200	29849	95.8	2272
300	3600	449TS	575	1LE23214DA613AA3	See SD200	40858	95.8	2200
350	3600	S449SS	575	1LE23214GA113AA3	See SD200	41992	95.8	2890
400	3600	S449SS	575	1LE23213AA313AA3	See SD200	52365	95.8	3065
4 Pole 575V Ball Bearing Short Shaft								
1	1800	143T	575	1LE23211AB213AA3	+	537	85.5	76
1 1/2	1800	145T	575	1LE23211AB313AA3	+	595	86.5	80
2	1800	145T	575	1LE23211AB413AA3		655	86.5	80
3	1800	182T	575	1LE23211CB113AA3		726	89.5	118
5	1800	184T	575	1LE23211CB313AA3		848	89.5	124
7 1/2	1800	213T	575	1LE23212AB113AA3		1117	91.7	191
10	1800	215T	575	1LE23212AB213AA3		1387	91.7	197
15	1800	254T	575	1LE23212BB113AA3		1826	92.4	289
20	1800	256T	575	1LE23212BB213AA3	+	2274	93.0	322
25	1800	284T	575	1LE23212CB113AA3		2587	93.6	445
30	1800	286T	575	1LE23212CB213AA3		3010	93.6	465
40	1800	324T	575	1LE23213AB113AA3		3998	94.1	666
50	1800	326T	575	1LE23213AB213AA3		4910	94.5	700
60	1800	364T	575	1LE23213CB113AA3		7043	95.0	930
75	1800	365T	575	1LE23213CB213AA3	+	8928	95.4	1000
100	1800	405T	575	1LE23214AB213AA3	+	11032	95.4	1160
125	1800	B444T	575	1LE23214EB113AA3	See SD200	14518	95.4	1600
150	1800	B445T	575	1LE23214EB213AA3	See SD200	16,878	95.8	1710
200	1800	B447T	575	1LE23214EB313AA3	See SD200	20529	96.2	2035
250	1800	B449T	575	1LE23214EB513AA3	See SD200	25755	96.2	2425
300	1800	B449T	575	1LE23214EB613AA3	See SD200	30036	96.2	3130

SD100 | Eff: NEMA Premium | Foot Mounted | 575V

Power HP	Speed RPM	NEMA Frame	Voltage	Base Part Number	Stock	List Price	Eff %	Weight (lbs)
4 Pole 575V Ball Bearing Short Shaft								
25	1800	284TS	575	1LE23212DB113AA3		2587	93.6	445
30	1800	286TS	575	1LE23212DB213AA3		3010	93.6	465
40	1800	324TS	575	1LE23213BB113AA3		3998	94.1	666
50	1800	326TS	575	1LE23213BB213AA3		4910	94.5	700
60	1800	364TS	575	1LE23213DB113AA3		7043	95.0	930
75	1800	365TS	575	1LE23213DB213AA3		8928	95.4	1000
100	1800	405TS	575	1LE23214BB213AA3		11032	95.4	1160
125	1800	444TS	575	1LE23214DB113AA3	See SD200	14518	95.4	1600
150	1800	445TS	575	1LE23214DB213AA3	See SD200	16878	95.8	1710
200	1800	447TS	575	1LE23214DB313AA3	See SD200	20529	96.2	2035
250	1800	449TS	575	1LE23214DB513AA3	See SD200	25755	96.2	2425
300	1800	449TS	575	1LE23214DB613AA3	See SD200	30036	96.2	3130
350	1800	S449SS	575	1LE23214GB213AA3	See SD200	39003	96.2	3190
400	1800	S449SS	575	1LE23214GB313AA3	See SD200	48649	96.2	3240
4 Pole 575V Roller Bearing Long Shaft								
125	1800	444T	575	1LE23214CB113AA3	See SD200	15,126	95.4	1600
150	1800	445T	575	1LE23214CB213AA3	See SD200	17,486	95.8	1710
200	1800	447T	575	1LE23214CB313AA3	See SD200	21137	96.2	2035
250	1800	449T	575	1LE23214CB513AA3	See SD200	26363	96.2	2425
300	1800	449T	575	1LE23214CB613AA3	See SD200	30644	96.2	3130
350	1800	S449LS	575	1LE23214FB213AA3	See SD200	39611	96.2	3190
400	1800	S449LS	575	1LE23214FB313AA3	See SD200	49,257	96.2	3240
6 Pole 575V Ball Bearing Long Shaft								
1	1200	145T	575	1LE23211AC313AA3		663	82.5	77
1 ½	1200	182T	575	1LE23211CC113AA3		747	87.5	113
2	1200	184T	575	1LE23211CC313AA3		835	88.5	122
3	1200	213T	575	1LE23212AC113AA3		1017	89.5	164
5	1200	215T	575	1LE23212AC213AA3		1433	89.5	176
7 ½	1200	254T	575	1LE23212BC113AA3		1852	91.0	292
10	1200	256T	575	1LE23212BC213AA3		2328	91.0	288
15	1200	284T	575	1LE23212CC113AA3		2954	91.7	400
20	1200	286T	575	1LE23212CC213AA3		3598	91.7	465
25	1200	324T	575	1LE23213AC113AA3		4235	93.0	640
30	1200	326T	575	1LE23213AC213AA3		5017	93.0	675
40	1200	364T	575	1LE23213CC113AA3		6803	94.1	863
50	1200	365T	575	1LE23213CC213AA3		7810	94.1	900
60	1200	404T	575	1LE23214AC113AA3		9150	94.5	1100
75	1200	405T	575	1LE23214AC213AA3		10772	94.5	1150
100	1200	B444T	575	1LE23214EC113AA3	See SD200	14724	95.0	1545
125	1200	B445T	575	1LE23214EC213AA3	See SD200	18079	95.0	1720
150	1200	B447T	575	1LE23214EC313AA3	See SD200	20228	95.8	1995
200	1200	B449T	575	1LE23214EC513AA3	See SD200	24761	95.8	2425
250	1200	B449T	575	1LE23214EC613AA3	See SD200	26944	95.8	2390

SD100 | Eff: NEMA Premium | Foot Mounted | 575V

Power HP	Speed RPM	NEMA Frame	Voltage	Base Part Number	Stock	List Price	Eff %	Weight (lbs)
6 Pole 575V Ball Bearing Short Shaft								
100	1200	444TS	575	1LE23214DC113AA3	See SD200	14724	95.0	1545
125	1200	445TS	575	1LE23214DC213AA3	See SD200	18079	95.0	1720
150	1200	447TS	575	1LE23214DC313AA3	See SD200	20228	95.8	1995
200	1200	449TS	575	1LE23214DC513AA3	See SD200	24761	95.8	2425
250	1200	449TS	575	1LE23214DC613AA3	See SD200	26944	95.8	2390
6 Pole 575V Roller Bearing Long Shaft								
100	1200	444T	575	1LE23214CC113AA3	See SD200	15332	95.0	1545
125	1200	445T	575	1LE23214CC213AA3	See SD200	18687	95.0	1720
150	1200	447T	575	1LE23214CC313AA3	See SD200	20836	95.8	1995
200	1200	449T	575	1LE23214CC513AA3	See SD200	25369	95.8	2425
250	1200	449T	575	1LE23214CC613AA3	See SD200	27552	95.8	2390
300	1200	S449LS	575	1LE23214FC113AA3	See SD200	48251	95.8	3240
8 Pole 575V Ball Bearing Long Shaft								
1	900	182T	575	1LE23211CD113AA3		900	81.5	106
1 ½	900	184T	575	1LE23211CD313AA3		1014	82.5	119
2	900	213T	575	1LE23212AD113AA3		1175	84.0	143
3	900	215T	575	1LE23212AD213AA3		1621	85.5	158
5	900	254T	575	1LE23212BD113AA3		2279	86.5	247
7 ½	900	256T	575	1LE23212BD213AA3		2630	87.5	279
10	900	284T	575	1LE23212CD113AA3		3511	91.0	375
15	900	286T	575	1LE23212CD213AA3		4569	91.0	430
20	900	324T	575	1LE23213AD113AA3		5585	91.0	567
25	900	326T	575	1LE23213AD213AA3		6487	90.2	600
30	900	364T	575	1LE23213CD113AA3		7676	91.0	800
40	900	365T	575	1LE23213CD213AA3		9283	91.7	875
50	900	404T	575	1LE23214AD113AA3		11091	92.4	1135
60	900	405T	575	1LE23214AD213AA3		12668	92.4	1300
75	900	B444T	575	1LE23214ED113AA3	See SD200	16694	93.6	1625
100	900	B445T	575	1LE23214ED213AA3	See SD200	20641	94.1	1900
125	900	B447T	575	1LE23214ED313AA3	See SD200	21897	94.1	2280
150	900	B447T	575	1LE23214ED413AA3	See SD200	27964	94.1	2280
8 Pole 575V Roller Bearing Long Shaft								
75	900	444T	575	1LE23214CD113AA3	See SD200	17302	93.6	1625
100	900	445T	575	1LE23214CD213AA3	See SD200	21249	94.1	1900
125	900	447T	575	1LE23214CD313AA3	See SD200	22505	94.1	2280
150	900	447T	575	1LE23214CD413AA3	See SD200	28572	94.1	2280
200	900	S449LS	575	1LE23214FD113AA3	See SD200	34838	94.5	3200
250	900	S449LS	575	1LE23214FD213AA3	See SD200	41045	94.5	3316

NEMA Premium is a certification mark of the National Electrical Manufacturer's Association
250HP and 300HP 4 pole and 6 pole - NEMA Design A

3.2.2.2. SD100 Low Maintenance



SD100 – Low Maintenance | No Regreasing | Eff: NEMA Premium | Foot Mounted

Power HP	Speed RPM	NEMA Frame	Voltage	Base Part Number	Stock	List Price	Eff %	Weight (lbs)
4 Pole 230/460V Ball Bearing Long Shaft								
1	1800	143T	230/460	1LE23231AB216AA3	+	555	85.5	76
1 ½	1800	145T	230/460	1LE23231AB316AA3	+	615	86.5	80
2	1800	145T	230/460	1LE23231AB416AA3	+	675	86.5	80
3	1800	182T	230/460	1LE23231CB116AA3	+	750	89.5	118
5	1800	184T	230/460	1LE23231CB316AA3	+	875	89.5	124
7 ½	1800	213T	230/460	1LE23232AB116AA3	+	1150	91.7	191
10	1800	215T	230/460	1LE23232AB216AA3	+	1430	91.7	197
15	1800	254T	230/460	1LE23232BB116AA3	+	1880	92.4	289
20	1800	256T	230/460	1LE23232BB216AA3	+	2340	93.0	322
25	1800	284T	230/460	1LE23232CB116AA3		2665	93.6	445
30	1800	286T	230/460	1LE23232CB216AA3		3100	93.6	465
40	1800	324T	230/460	1LE23233AB116AA3		4120	94.1	666
50	1800	326T	230/460	1LE23233AB216AA3		5055	94.5	700
60	1800	364T	230/460	1LE23233CB116AA3		7255	95.0	930
75	1800	365T	230/460	1LE23233CB216AA3		9195	95.4	1000
4 Pole 230/460V Ball Bearing Short Shaft								
25	1800	284TS	230/460	1LE23232DB116AA3		2665	93.6	445
30	1800	286TS	230/460	1LE23232DB216AA3		3100	93.6	465
40	1800	324TS	230/460	1LE23233BB116AA3		4120	94.1	666
50	1800	326TS	230/460	1LE23233BB216AA3		5055	94.5	700
60	1800	364TS	230/460	1LE23233DB116AA3		7255	95.0	930
75	1800	365TS	230/460	1LE23233DB216AA3		9195	95.4	1000

NEMA Premium is a certification mark of the National Electrical Manufacturer's Association

SD100 – Low Maintenance | No Regreasing | Eff: NEMA Premium | Foot Mounted

Power HP	Speed RPM	NEMA Frame	Voltage	Base Part Number	Stock	List Price	Eff %	Weight (lbs)
6 Pole 230/460V Ball Bearing Long Shaft								
1	1200	145T	230/460	1LE23231AC316AA3	+	685	82.5	77
1 ½	1200	182T	230/460	1LE23231CC116AA3	+	770	87.5	113
2	1200	184T	230/460	1LE23231CC316AA3	+	860	88.5	122
3	1200	213T	230/460	1LE23232AC116AA3	+	1050	89.5	164
5	1200	215T	230/460	1LE23232AC216AA3	+	1475	89.5	176
7 ½	1200	254T	230/460	1LE23232BC116AA3	+	1910	91.0	292
10	1200	256T	230/460	1LE23232BC216AA3	+	2400	91.0	288
15	1200	284T	230/460	1LE23232CC116AA3	+	3045	91.7	400
20	1200	286T	230/460	1LE23232CC216AA3	+	3705	91.7	465
25	1200	324T	230/460	1LE23233AC116AA3		4360	93.0	640
30	1200	326T	230/460	1LE23233AC216AA3		5170	93.0	675
40	1200	364T	230/460	1LE23233CC116AA3		7005	94.1	863
50	1200	365T	230/460	1LE23233CC216AA3		8045	94.1	900

NEMA Premium is a certification mark of the National Electrical Manufacturer's Association

3.2.2.3. SD100 IEEE841



SD100 IEEE841 | Eff: NEMA Premium | Foot Mounted

Power HP	Speed RPM	NEMA Frame	Voltage	Base Part Number	Stock	List Price	Eff %	Weight (lbs)
2 Pole 460V Ball Bearing Long Shaft								
1	3600	143T	460	1LE24211AA112AA3	+	787	82.5	75
1 ½	3600	143T	460	1LE24211AA212AA3	+	788	84.0	70
2	3600	145T	460	1LE24211AA312AA3	+	904	85.5	72
3	3600	182T	460	1LE24211CA112AA3	+	947	86.5	107
5	3600	184T	460	1LE24211CA312AA3	+	1159	88.5	118
7 ½	3600	213T	460	1LE24212AA112AA3	+	1421	89.5	160
10	3600	215T	460	1LE24212AA212AA3	+	1634	90.2	174
15	3600	254T	460	1LE24212BA112AA3	+	2216	91.0	287
20	3600	256T	460	1LE24212BA212AA3	+	2720	91.0	323
2 Pole 460V Ball Bearing Short Shaft								
25	3600	284TS	460	1LE24212DA112AA3	+	3231	91.7	415
30	3600	286TS	460	1LE24212DA212AA3	+	3775	91.7	430
40	3600	324TS	460	1LE24213BA112AA3	+	4978	93.6	575
50	3600	326TS	460	1LE24213BA212AA3	+	6328	93.6	610
60	3600	364TS	460	1LE24213DA112AA3	+	8398	93.6	717
75	3600	365TS	460	1LE24213DA212AA3	+	10545	94.1	815
100	3600	405TS	460	1LE24214BA212AA3	+	14007	94.1	1100
125	3600	444TS	460	1LE24214DA112AA3	See SD200	17992	95.0	1454
150	3600	445TS	460	1LE24214DA212AA3	See SD200	21035	95.0	1615
200	3600	447TS	460	1LE24214DA312AA3	See SD200	26380	95.4	1890
250	3600	449TS	460	1LE24214DA512AA3	See SD200	33581	95.8	2272
300	3600	449TS	460	1LE24214DA612AA3	See SD200	42635	95.8	2200
350	3600	S449SS	460	1LE24214GA112AA3	See SD200	51006	95.8	2890
400	3600	S449SS	460	1LE24214GA312AA3	See SD200	57207	95.8	3065

2 Pole S449SS CW rotation facing NDE as standard

NEMA Premium is a certification mark of the National Electrical Manufacturer's Association

SD100 IEEE841 | Eff: NEMA Premium | Foot Mounted

Power HP	Speed RPM	NEMA Frame	Voltage	Base Part Number	Stock	List Price	Eff %	Weight (lbs)
4 Pole 460V Ball Bearing Long Shaft								
1	1800	143T	460	1LE24211AB212AA3	+	762	85.5	76
1 ½	1800	145T	460	1LE24211AB312AA3	+	822	86.5	80
2	1800	145T	460	1LE24211AB412AA3	+	878	86.5	80
3	1800	182T	460	1LE24211CB112AA3	+	907	89.5	118
5	1800	184T	460	1LE24211CB312AA3	+	1039	89.5	124
7 ½	1800	213T	460	1LE24212AB112AA3	+	1380	91.7	191
10	1800	215T	460	1LE24212AB212AA3	+	1,652	91.7	197
15	1800	254T	460	1LE24212BB112AA3	+	2,177	92.4	289
20	1800	256T	460	1LE24212BB212AA3	+	2,806	93.0	322
25	1800	284T	460	1LE24212CB112AA3	+	3086	93.6	445
30	1800	286T	460	1LE24212CB212AA3	+	3588	93.6	465
40	1800	324T	460	1LE24213AB112AA3	+	4767	94.1	666
50	1800	326T	460	1LE24213AB212AA3	+	5803	94.5	700
60	1800	364T	460	1LE24213CB112AA3	+	8253	95.0	930
75	1800	365T	460	1LE24213CB212AA3	+	10279	95.4	1000
100	1800	405T	460	1LE24214AB212AA3	+	12,699	95.4	1160
125	1800	B444T	460	1LE24214EB112AA3	See SD200 841	16,570	95.4	1600
150	1800	B445T	460	1LE24214EB212AA3	See SD200 841	18,742	95.8	1710
200	1800	B447T	460	1LE24214EB312AA3	See SD200 841	22796	96.2	2035
250	1800	B449T	460	1LE24214EB512AA3	See SD200 841	28890	96.2	2425
4 Pole 460V Ball Bearing Short Shaft								
25	1800	284TS	460	1LE24212DB112AA3	+	3086	93.6	445
30	1800	286TS	460	1LE24212DB212AA3	+	3588	93.6	465
40	1800	324TS	460	1LE24213BB112AA3	+	4767	94.1	666
50	1800	326TS	460	1LE24213BB212AA3	+	5803	94.5	700
60	1800	364TS	460	1LE24213DB112AA3	+	8253	95.0	930
75	1800	365TS	460	1LE24213DB212AA3	+	10279	95.4	1000
100	1800	405TS	460	1LE24214BB212AA3	+	12,699	95.4	1160
125	1800	444TS	460	1LE24214DB112AA3	See SD200 841	16,570	95.4	1600
150	1800	445TS	460	1LE24214DB212AA3	See SD200 841	18,742	95.8	1710
200	1800	447TS	460	1LE24214DB312AA3	See SD200 841	22796	96.2	2035
250	1800	449TS	460	1LE24214DB512AA3	See SD200 841	28890	96.2	2425
300	1800	S449SS	460	1LE24214GB112AA3	See SD200 841	39177	96.2	3130
350	1800	S449SS	460	1LE24214GB212AA3	See SD200 841	47236	96.2	3190
400	1800	S449SS	460	1LE24214GB312AA3	See SD200 841	52986	96.2	3240
4 Pole 460V Roller Bearing Long Shaft								
125	1800	444T	460	1LE24214CB112AA3	See SD200 841	17,178	95.4	1600
150	1800	445T	460	1LE24214CB212AA3	See SD200 841	19,350	95.8	1710
200	1800	447T	460	1LE24214CB312AA3	See SD200 841	23404	96.2	2035
250	1800	449T	460	1LE24214CB512AA3	See SD200 841	29498	96.2	2425
300	1800	S449LS	460	1LE24214FB112AA3	See SD200 841	39785	96.2	3130
350	1800	S449LS	460	1LE24214FB212AA3	See SD200 841	47884	96.2	3190
400	1800	S449LS	460	1LE24214FB312AA3	See SD200 841	53594	96.2	3240

250HP and 300HP 4 pole and 6 pole - NEMA Design A

NEMA Premium is a certification mark of the National Electrical Manufacturer's Association

SD100 IEEE841 | Eff: NEMA Premium | Foot Mounted

Power HP	Speed RPM	NEMA Frame	Voltage	Base Part Number	Stock	List Price	Eff %	Weight (lbs)
6 Pole 460V Ball Bearing Long Shaft								
1	1200	145T	460	1LE24211AC312AA3	+	898	82.5	77
1 ½	1200	182T	460	1LE24211CC112AA3	+	1006	87.5	113
2	1200	184T	460	1LE24211CC312AA3	+	1071	88.5	122
3	1200	213T	460	1LE24212AC112AA3	+	1350	89.5	164
5	1200	215T	460	1LE24212AC212AA3	+	1787	89.5	176
7 ½	1200	254T	460	1LE24212BC112AA3	+	2284	91.0	292
10	1200	256T	460	1LE24212BC212AA3	+	2840	91.0	288
15	1200	284T	460	1LE24212CC112AA3	+	3541	91.7	400
20	1200	286T	460	1LE24212CC212AA3	+	4316	91.7	465
25	1200	324T	460	1LE24213AC112AA3	+	5227	93.0	640
30	1200	326T	460	1LE24213AC212AA3	+	6022	93.0	675
40	1200	364T	460	1LE24213CC112AA3	+	8160	94.1	863
50	1200	365T	460	1LE24213CC212AA3	+	9287	94.1	900
60	1200	404T	460	1LE24214AC112AA3	+	10599	94.5	1100
75	1200	405T	460	1LE24214AC212AA3	+	12368	94.5	1150
100	1200	B444T	460	1LE24214EC112AA3	See SD200 841	17054	95.0	1545
125	1200	B445T	460	1LE24214EC212AA3	See SD200 841	20577	95.0	1720
150	1200	B447T	460	1LE24214EC312AA3	See SD200 841	22602	95.8	1995
200	1200	B449T	460	1LE24214EC512AA3	See SD200 841	27413	95.8	2425
250	1200	B449T	460	1LE24214EC612AA3	See SD200 841	30125	95.8	2390
6 Pole 460V Ball Bearing Short Shaft								
100	1200	444TS	460	1LE24214DC112AA3	See SD200 841	17054	95.0	1545
125	1200	445TS	460	1LE24214DC212AA3	See SD200 841	20577	95.0	1720
150	1200	447TS	460	1LE24214DC312AA3	See SD200 841	22602	95.8	1995
200	1200	449TS	460	1LE24214DC512AA3	See SD200 841	27413	95.8	2425
250	1200	449TS	460	1LE24214DC612AA3	See SD200 841	30125	95.8	2390
300	1200	S449SS	460	1LE24214GC112AA3	See SD200 841	52342	95.8	3240
6 Pole 460V Roller Bearing Long Shaft								
100	1200	444T	460	1LE24214CC112AA3	See SD200 841	17662	95.0	1545
125	1200	445T	460	1LE24214CC212AA3	See SD200 841	21185	95.0	1720
150	1200	447T	460	1LE24214CC312AA3	See SD200 841	23210	95.8	1995
200	1200	449T	460	1LE24214CC512AA3	See SD200 841	28021	95.8	2425
250	1200	449T	460	1LE24214CC612AA3	See SD200 841	30733	95.8	2390
300	1200	S449LS	460	1LE24214FC112AA3	See SD200 841	52950	95.8	3240

250HP and 300HP 4 pole and 6 pole - NEMA Design A

NEMA Premium is a certification mark of the National Electrical Manufacturer's Association

SD100 IEEE841 | Eff: NEMA Premium | Foot Mounted

Power HP	Speed RPM	NEMA Frame	Voltage	Base Part Number	Stock	List Price	Eff %	Weight (lbs)
8 Pole 460V Ball Bearing Long Shaft								
1	900	182T	460	1LE24211CD112AA3		1457	81.5	106
1 ½	900	184T	460	1LE24211CD312AA3	+	1719	82.5	119
2	900	213T	460	1LE24212AD112AA3	+	2023	84.0	145
3	900	215T	460	1LE24212AD212AA3	+	2565	85.5	160
5	900	254T	460	1LE24212BD112AA3	+	3428	86.5	247
7 ½	900	256T	460	1LE24212BD212AA3	+	4297	87.5	279
10	900	284T	460	1LE24212CD112AA3	+	4398	90.2	362
15	900	286T	460	1LE24212CD212AA3	+	5623	90.2	420
20	900	324T	460	1LE24213AD112AA3	+	6875	91.0	570
25	900	326T	460	1LE24213AD212AA3	+	7986	90.2	582
30	900	364T	460	1LE24213CD112AA3	+	9453	91.7	740
40	900	365T	460	1LE24213CD212AA3	+	11428	91.7	840
50	900	404T	460	1LE24214AD112AA3	+	13302	92.4	1116
60	900	405T	460	1LE24214AD212AA3	+	14927	92.4	1182
75	900	B444T	460	1LE24214ED112AA3	See SD200 841	19848	93.6	1525
100	900	B445T	460	1LE24214ED212AA3	See SD200 841	24322	94.1	1697
125	900	B447T	460	1LE24214ED312AA3	See SD200 841	24984	94.1	2018
150	900	B449T	460	1LE24214ED512AA3	See SD200 841	31945	94.1	2480
8 Pole 460V Ball Bearing Short Shaft								
75	900	444TS	460	1LE24214DD112AA3	See SD200 841	19848	95.8	1525
100	900	445TS	460	1LE24214DD212AA3	See SD200 841	24322	94.1	1697
125	900	447TS	460	1LE24214DD312AA3	See SD200 841	24984	94.1	2018
150	900	449TS	460	1LE24214DD512AA3	See SD200 841	31945	94.1	2480
8 Pole 460V Roller Bearing Long Shaft								
75	900	444T	460	1LE24214CD112AA3	See SD200 841	20456	93.6	1525
100	900	445T	460	1LE24214CD212AA3	See SD200 841	24930	94.1	1697
125	900	447T	460	1LE24214CD312AA3	See SD200 841	25592	94.1	2018
150	900	449T	460	1LE24214CD512AA3	See SD200 841	32553	94.1	2480
200	900	S449LS	460	1LE24214FD112AA3	See SD200 841	46134	94.5	3200
250	900	S449LS	460	1LE24214FD212AA3	See SD200 841	50486	94.5	3220

NEMA Premium is a certification mark of the National Electrical Manufacturer's Association

SD100 IEEE841 | Eff: NEMA Premium | C-Face Round Body

Power HP	Speed RPM	NEMA Frame	Voltage	Base Part Number	Stock	List Price	Eff %	Weight (lbs)
2 Pole 460V Ball Bearing Long Shaft								
1	3600	143TC	460	1LE24211AA112GA3	+	877	82.5	75
1 ½	3600	143TC	460	1LE24211AA212GA3	+	878	84.0	70
2	3600	145TC	460	1LE24211AA312GA3	+	994	85.5	72
3	3600	182TC	460	1LE24211CA112GA3	+	1079	86.5	107
5	3600	184TC	460	1LE24211CA312GA3	+	1291	88.5	118
7 ½	3600	213TC	460	1LE24212AA112GA3	+	1553	89.5	160
10	3600	215TC	460	1LE24212AA212GA3	+	1766	90.2	174
15	3600	254TC	460	1LE24212BA112GA3	+	2396	91.0	287
20	3600	256TC	460	1LE24212BA212GA3	+	2900	91.0	323
4 Pole 460V Ball Bearing Long Shaft								
1	1800	143TC	460	1LE24211AB212GA3	+	852	85.5	76
1 ½	1800	145TC	460	1LE24211AB312GA3	+	912	86.5	80
2	1800	145TC	460	1LE24211AB412GA3	+	968	86.5	80
3	1800	182TC	460	1LE24211CB112GA3	+	1039	89.5	118
5	1800	184TC	460	1LE24211CB312GA3	+	1171	89.5	124
7 ½	1800	213TC	460	1LE24212AB112GA3	+	1512	91.7	191
10	1800	215TC	460	1LE24212AB212GA3	+	1784	91.7	197
15	1800	254TC	460	1LE24212BB112GA3	+	2357	92.4	289
20	1800	256TC	460	1LE24212BB212GA3	+	2986	93.0	322

NEMA Premium is a certification mark of the National Electrical Manufacturer's Association

SD100 IEEE841 | Eff: NEMA Premium | Foot Mounted | 575V

Power HP	Speed RPM	NEMA Frame	Voltage	Base Part Number	Stock	List Price	Eff %	Weight (lbs)
2 Pole 575V Ball Bearing Long Shaft								
1	3600	143T	575	1LE24211AA113AA3		787	82.5	75
1 ½	3600	143T	575	1LE24211AA213AA3		788	84.0	70
2	3600	145T	575	1LE24211AA313AA3		904	85.5	72
3	3600	182T	575	1LE24211CA113AA3		947	86.5	107
5	3600	184T	575	1LE24211CA313AA3		1159	88.5	118
7 ½	3600	213T	575	1LE24212AA113AA3		1421	89.5	160
10	3600	215T	575	1LE24212AA213AA3		1634	90.2	174
15	3600	254T	575	1LE24212BA113AA3		2216	91.0	287
20	3600	256T	575	1LE24212BA213AA3		2720	91.0	323
2 Pole 575V Ball Bearing Short Shaft								
25	3600	284TS	575	1LE24212DA113AA3		3231	91.7	415
30	3600	286TS	575	1LE24212DA213AA3		3775	91.7	430
40	3600	324TS	575	1LE24213BA113AA3		4978	93.6	575
50	3600	326TS	575	1LE24213BA213AA3		6328	93.6	610
60	3600	364TS	575	1LE24213DA113AA3		8398	93.6	717
75	3600	365TS	575	1LE24213DA213AA3		10545	94.1	815
100	3600	405TS	575	1LE24214BA213AA3		14007	94.1	1100
125	3600	444TS	575	1LE24214DA113AA3	See SD200	17992	95.0	1454
150	3600	445TS	575	1LE24214DA213AA3	See SD200	21035	95.0	1615
200	3600	447TS	575	1LE24214DA313AA3	See SD200	26380	95.4	1890
250	3600	449TS	575	1LE24214DA513AA3	See SD200	33581	95.8	2272
300	3600	449TS	575	1LE24214DA613AA3	See SD200	42635	95.8	2200
350	3600	S449SS	575	1LE24214GA113AA3	See SD200	51006	95.8	2890
400	3600	S449SS	575	1LE24214GA313AA3	See SD200	57207	95.8	3065
4 Pole 575V Ball Bearing Long Shaft								
1	1800	143T	575	1LE24211AB213AA3		762	85.5	76
1 ½	1800	145T	575	1LE24211AB313AA3	+	822	86.5	80
2	1800	145T	575	1LE24211AB413AA3		878	86.5	80
3	1800	182T	575	1LE24211CB113AA3		907	89.5	118
5	1800	184T	575	1LE24211CB313AA3		1039	89.5	124
7 ½	1800	213T	575	1LE24212AB113AA3		1380	91.7	191
10	1800	215T	575	1LE24212AB213AA3		1652	91.7	197
15	1800	254T	575	1LE24212BB113AA3		2177	92.4	289
20	1800	256T	575	1LE24212BB213AA3		2806	93.0	322
25	1800	284T	575	1LE24212CB113AA3		3086	93.6	445
30	1800	286T	575	1LE24212CB213AA3		3588	93.6	465
40	1800	324T	575	1LE24213AB113AA3		4767	94.1	666
50	1800	326T	575	1LE24213AB213AA3	+	5803	94.5	700
60	1800	364T	575	1LE24213CB113AA3	+	8253	95.0	930
75	1800	365T	575	1LE24213CB213AA3		10279	95.4	1000
100	1800	405T	575	1LE24214AB213AA3		12699	95.4	1160
125	1800	B444T	575	1LE24214EB113AA3	See SD200 841	16570	95.4	1600
150	1800	B445T	575	1LE24214EB213AA3	See SD200 841	18742	95.8	1710
200	1800	B447T	575	1LE24214EB313AA3	See SD200 841	22796	96.2	2035
250	1800	B449T	575	1LE24214EB513AA3	See SD200 841	28890	96.2	2425

SD100 IEEE841 | Eff: NEMA Premium | Foot Mounted | 575V

Power HP	Speed RPM	NEMA Frame	Voltage	Base Part Number	Stock	List Price	Eff %	Weight (lbs)
4 Pole 575V Ball Bearing Short Shaft								
25	1800	284TS	575	1LE24212DB113AA3		3086	93.6	445
30	1800	286TS	575	1LE24212DB213AA3		3588	93.6	465
40	1800	324TS	575	1LE24213BB113AA3		4767	94.1	666
50	1800	326TS	575	1LE24213BB213AA3		5803	94.5	700
60	1800	364TS	575	1LE24213DB113AA3		8253	95.0	930
75	1800	365TS	575	1LE24213DB213AA3		10279	95.4	1000
100	1800	405TS	575	1LE24214BB213AA3		12699	95.4	1160
125	1800	444TS	575	1LE24214DB113AA3	See SD200 841	16570	95.4	1600
150	1800	445TS	575	1LE24214DB213AA3	See SD200 841	18742	95.8	1710
200	1800	447TS	575	1LE24214DB313AA3	See SD200 841	22796	96.2	2035
250	1800	449TS	575	1LE24214DB513AA3	See SD200 841	28890	96.2	2425
300	1800	S449SS	575	1LE24214GB113AA3	See SD200 841	39177	96.2	3130
350	1800	S449SS	575	1LE24214GB213AA3	See SD200 841	47236	96.2	3190
400	1800	S449SS	575	1LE24214GB313AA3	See SD200 841	52986	96.2	3240
4 Pole 575V Roller Bearing Long Shaft								
125	1800	444T	575	1LE24214CB113AA3	See SD200 841	17178	95.4	1600
150	1800	445T	575	1LE24214CB213AA3	See SD200 841	19350	95.8	1710
200	1800	447T	575	1LE24214CB313AA3	See SD200 841	23404	96.2	2035
250	1800	449T	575	1LE24214CB513AA3	See SD200 841	29498	96.2	2425
300	1800	S449LS	575	1LE24214FB113AA3	See SD200 841	39785	96.2	3130
350	1800	S449LS	575	1LE24214FB213AA3	See SD200 841	47884	96.2	3190
400	1800	S449LS	575	1LE24214FB313AA3	See SD200 841	53594	96.2	3240
6 Pole 575V Ball Bearing Long Shaft								
1	1200	145T	575	1LE24211AC313AA3		898	82.5	77
1 ½	1200	182T	575	1LE24211CC113AA3		1006	87.5	113
2	1200	184T	575	1LE24211CC313AA3		1071	88.5	122
3	1200	213T	575	1LE24212AC113AA3		1350	89.5	164
5	1200	215T	575	1LE24212AC213AA3		1787	89.5	176
7 ½	1200	254T	575	1LE24212BC113AA3		2284	91.0	292
10	1200	256T	575	1LE24212BC213AA3		2840	91.0	288
15	1200	284T	575	1LE24212CC113AA3		3541	91.7	400
20	1200	286T	575	1LE24212CC213AA3		4316	91.7	465
25	1200	324T	575	1LE24213AC113AA3		5227	93.0	640
30	1200	326T	575	1LE24213AC213AA3		6022	93.0	675
40	1200	364T	575	1LE24213CC113AA3	+	8160	94.1	863
50	1200	365T	575	1LE24213CC213AA3	+	9287	94.1	900
60	1200	404T	575	1LE24214AC113AA3	+	10599	94.5	1100
75	1200	405T	575	1LE24214AC213AA3	+	12368	94.5	1150
100	1200	B444T	575	1LE24214EC113AA3	See SD200 841	17054	95.0	1545
125	1200	B445T	575	1LE24214EC213AA3	See SD200 841	20577	95.0	1720
150	1200	B447T	575	1LE24214EC313AA3	See SD200 841	22602	95.8	1995

SD100 IEEE841 | Eff: NEMA Premium | Foot Mounted | 575V

Power HP	Speed RPM	NEMA Frame	Voltage	Base Part Number	Stock	List Price	Eff %	Weight (lbs)
6 Pole 575V Ball Bearing Long Shaft								
200	1200	B449T	575	1LE24214EC513AA3	See SD200 841	27413	95.8	2425
250	1200	B449T	575	1LE24214EC613AA3	See SD200 841	30125	95.8	2390
6 Pole 575V Ball Bearing Short Shaft								
100	1200	444TS	575	1LE24214DC113AA3	See SD200 841	17054	95.0	1545
125	1200	445TS	575	1LE24214DC213AA3	See SD200 841	20577	95.0	1720
150	1200	447TS	575	1LE24214DC313AA3	See SD200 841	22602	95.8	1995
200	1200	449TS	575	1LE24214DC513AA3	See SD200 841	27413	95.8	2425
250	1200	449TS	575	1LE24214DC613AA3	See SD200 841	30125	95.8	2390
300	1200	S449SS	575	1LE24214GC113AA3	See SD200 841	52342	95.8	3240
6 Pole 575V Roller Bearing Long Shaft								
100	1200	444T	575	1LE24214CC113AA3	See SD200 841	17662	95.0	1545
125	1200	445T	575	1LE24214CC213AA3	See SD200 841	21185	95.0	1720
150	1200	447T	575	1LE24214CC313AA3	See SD200 841	23210	95.8	1995
200	1200	449T	575	1LE24214CC513AA3	See SD200 841	28021	95.8	2425
250	1200	449T	575	1LE24214CC613AA3	See SD200 841	30733	95.8	2390
300	1200	S449LS	575	1LE24214FC113AA3	See SD200 841	52950	95.8	3240
8 Pole 575V Ball Bearing Long Shaft								
1	900	182T	575	1LE24211CD113AA3		1457	81.5	106
1 ½	900	184T	575	1LE24211CD313AA3		1719	82.5	119
2	900	213T	575	1LE24212AD113AA3		2023	84.0	145
3	900	215T	575	1LE24212AD213AA3		2565	85.5	160
5	900	254T	575	1LE24212BD113AA3		3428	86.5	247
7 ½	900	256T	575	1LE24212BD213AA3		4297	87.5	279
10	900	284T	575	1LE24212CD113AA3		4398	90.2	362
15	900	286T	575	1LE24212CD213AA3		5623	90.2	420
20	900	324T	575	1LE24213AD113AA3		6875	91.0	570
25	900	326T	575	1LE24213AD213AA3		7986	90.2	582
30	900	364T	575	1LE24213CD113AA3		9453	91.7	740
40	900	365T	575	1LE24213CD213AA3		11428	91.7	840
50	900	404T	575	1LE24214AD113AA3		13302	92.4	1116
60	900	405T	575	1LE24214AD213AA3		14927	92.4	1182
75	900	B444T	575	1LE24214ED113AA3	See SD200 841	19848	93.6	1525
100	900	B445T	575	1LE24214ED213AA3	See SD200 841	24322	94.1	1697
125	900	B447T	575	1LE24214ED313AA3	See SD200 841	24984	94.1	2018
150	900	B449T	575	1LE24214ED513AA3	See SD200 841	31945	94.1	2480
8 Pole 575V Roller Bearing Long Shaft								
75	900	444T	575	1LE24214CD113AA3	See SD200 841	20,456	93.6	1525
100	900	445T	575	1LE24214CD213AA3	See SD200 841	24,930	94.1	1697
125	900	447T	575	1LE24214CD313AA3	See SD200 841	25592	94.1	2018
150	900	449T	575	1LE24214CD513AA3	See SD200 841	32553	94.1	2480
200	900	S449LS	575	1LE24214FD113AA3	See SD200 841	46134	94.5	3200
250	900	S449LS	575	1LE24214FD213AA3	See SD200 841	50486	94.5	3220

250HP and 300HP 4 pole and 6 pole - NEMA Design A

NEMA Premium is a certification mark of the National Electrical Manufacturer's Association

SD100 IEEE841 | Eff: NEMA Premium | C-Face Round Body | 575V

Power HP	Speed RPM	NEMA Frame	Voltage	Base Part Number	Stock	List Price	Eff %	Weight (lbs)
2 Pole 575V Ball Bearing Long Shaft								
1	3600	143TC	575	1LE24211AA113GA3		877	82.5	75
1 ½	3600	143TC	575	1LE24211AA213GA3		878	84.0	70
2	3600	145TC	575	1LE24211AA313GA3		994	85.5	72
3	3600	182TC	575	1LE24211CA113GA3		1079	86.5	107
5	3600	184TC	575	1LE24211CA313GA3		1291	88.5	118
7 ½	3600	213TC	575	1LE24212AA113GA3		1553	89.5	160
10	3600	215TC	575	1LE24212AA213GA3		1766	90.2	174
15	3600	254TC	575	1LE24212BA113GA3		2396	91.0	287
20	3600	256TC	575	1LE24212BA213GA3		2900	91.0	323
4 Pole 575V Ball Bearing Long Shaft								
1	1800	143TC	575	1LE24211AB213GA3		852	85.5	76
1 ½	1800	145TC	575	1LE24211AB313GA3		912	86.5	80
2	1800	145TC	575	1LE24211AB413GA3		968	86.5	80
3	1800	182TC	575	1LE24211CB113GA3		1039	89.5	118
5	1800	184TC	575	1LE24211CB313GA3		1171	89.5	124
7 ½	1800	213TC	575	1LE24212AB113GA3		1512	91.7	191
10	1800	215TC	575	1LE24212AB213GA3		1784	91.7	197
15	1800	254TC	575	1LE24212BB113GA3		2357	92.4	289
20	1800	256TC	575	1LE24212BB213GA3		2986	93.0	322

NEMA Premium is a certification mark of the National Electrical Manufacturer's Association

3.2.2.4. SD661



SD661 | Eff: NEMA Premium | Foot Mounted

Power HP	Speed RPM	NEMA Frame	Voltage	Base Part Number	Stock	List Price	Eff %	Weight (lbs)
4 Pole 460 Roller Bearing Long Shaft								
5	1800	184T	460	1LE24221CB312AA3	+	1039	89.5	124
7 ½	1800	213T	460	1LE24222AB112AA3	+	1568	91.7	191
10	1800	215T	460	1LE24222AB212AA3	+	1842	91.7	197
15	1800	254T	460	1LE24222BB112AA3	+	2435	92.4	289
20	1800	256T	460	1LE24222BB212AA3	+	3113	93.0	322
25	1800	284T	460	1LE24222CB112AA3	+	3413	93.6	445
30	1800	286T	460	1LE24222CB212AA3	+	3910	93.6	465
40	1800	324T	460	1LE24223AB112AA3	+	5176	94.1	666
40	1800	364T	460	1LE24223CC112AA3	+	8659	94.1	863
50	1800	326T	460	1LE24223AB212AA3	+	6229	94.5	700
60	1800	364T	460	1LE24223CB112AA3	+	8752	95.0	930
75	1800	365T	460	1LE24223CB212AA3	+	10814	95.4	1000
6 Pole 460 Roller Bearing Long Shaft								
7 ½	1200	254T	460	1LE24222BC112AA3		2542	91.0	272
10	1200	256T	460	1LE24222BC212AA3		3147	91.0	288
15	1200	284T	460	1LE24222CC112AA3	+	3868	91.7	400
20	1200	286T	460	1LE24222CC212AA3	+	4638	91.7	465
25	1200	324T	460	1LE24223AC112AA3	+	5636	93.0	640
30	1200	326T	460	1LE24223AC212AA3	+	6448	93.0	675
40	1200	364T	460	1LE24223CC112AA3	+	8659	94.1	839
50	1200	365T	460	1LE24223CC212AA3	+	9822	94.1	900

NEMA Premium is a certification mark of the National Electrical Manufacturer's Association

3.2.3. Explosion Proof Low Voltage NEMA Motors

Introduction

Explosion Proof low voltage NEMA motors are **not only** designed and built to operate under harsh environments in the industry, including but not limited to petrochemical and the **food industry**. Fans, compressors, pumps, and conveyors are some of the many applications. These motors are design to meet or exceed the NEMA Premium® efficiency (MG1 Table 12.12) as well as the high requirements for safety and protection established by the NFPA 70 code NEC®. These motors are prepared for different hazardous atmospheres for gas and dust protection, its IP65 ingress protection provides reliability and safety assurance in all cases. The construction of these motors is backed by its 3-to-5-year warranty.



Performance Specification

		XP100	XP100 ID1
HP Range	3600 RPM		1-300 HP
	1800 RPM		
	1200 RPM	1-250 HP	1-200 HP
	900 RPM	1-200 HP	–
Frame Size	140T – 440T	140T-449T, 180JP-210JP	
Standard Voltage (3~ 60 Hz)	230V/460V (Suitable for 208V)	FS 140-250	
	230V/460V	1-100 HP	
	460V	1-300 HP	
	575V		
Efficiency	NEMA Premium® (MG1-Table 12-12)	1-300 HP	
	1.15 @ 55°C (Temp Code T3C)	FS 140-360	FS 140-440
Service Factor	1.15 @ 55°C (Temp Code T2A)	–	FS 140-440
	1.15 @ 55°C (Temp Code T3)	FS 360-447	–
	1.15 @ 40°C (Temp Code T3C)	FS 360-447	–
	1.0 @ 40°C (Temp Code T3C)	FS 449	–
Insulation	Non-Hygroscopic	Class F	
Temperature Rise	Class B	@ 1.0SF	
	Class F	@ 1.15SF	
Conduit Box (Oversized)	Oversized	Cast Iron	
Fan Cover		Cast Iron	
Cooling Fan	Bi-Directional	Polypropylene	
Rotor	Die Cast Aluminum	FS 140-449	
Ingress Protection	NEMA	IP65	
Hazardous Location	Gas	CL I, Div 1 Gr. C&D	CL I, Div 1 Gr. D
	Dust	CL II, Div 1, Gr F&G ¹	–
Inverter Duty ⁵	Variable Torque 20:1	FS 140-440	FS 140-440
	Constant Torque 4:1	FS 140-447	FS 140-447

1. Group E as option (M32)

Frame and End Shields

The Explosion Proof XP100 and XP100 ID1 feature cast iron frame, end shields and an easy-to-access diagonally split, oversized terminal box; the terminal box is provided with a neoprene gasket and includes a heavy-duty ground lug and non-wicking clearly and permanently marked leads. These characteristics, its high strength, zinc-plated hardware, epoxy paint, and stainless-steel nameplate provide exceptional structural integrity and resistance to rust and corrosion, making them suitable for severe duty applications in harsh environments.

Rotor and Stator Windings

A unique offset rotor bar design provides improved efficiency, while larger bars and end rings reduce resistance for lower rotor losses. Each die cast aluminum rotor assembly is dynamically balanced for extended bearing life and includes a high-strength carbon steel (C1045) shaft for maximum rotor performance.

The stator is manufactured with premium electrical C5 grade steel lamination and copper electrical magnet wire that furthers the reduction in losses.

Insulation

The proprietary Class F non-hygroscopic insulation system, NEMA Class B temperature rise, provides an extra margin of thermal life. The varnish system application ensures maximum wire penetration to provide protection from moisture, corrosion, and electrical shock. This insulation system meets or exceeds NEMA MG1 2014 Part 31, making the motors suitable for variable speed drives in constant torque (4:1) and variable torque (20:1). All windings are tested for CIV.

Cooling System

A non-sparking, bi-directional fan is locked and keyed to the shaft. Its low-inertia design reduces windage losses, improves airflow, reduces noise, and provides dependable cooling. Cast Iron fan covers are provided for all frame sizes.

Bearings

Single shielded bearings are used for better bearing protection against contaminants.

3.2.3.1. XP100

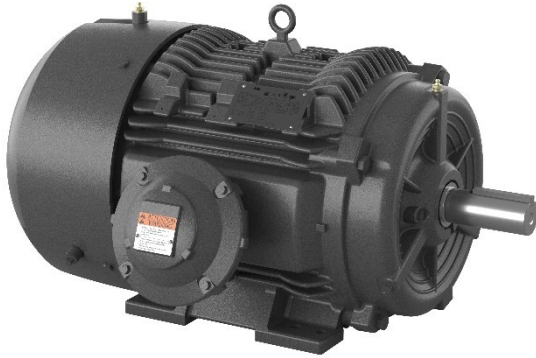

XP100 | Eff: NEMA Premium | Foot Mounted | Division 1, Class I, Groups C & D, Class II, Groups F & G

Power HP	Speed RPM	NEMA Frame	Voltage	Base Part Number	Stock	List Price	Eff %	Weight (lbs)
2 Pole 230/460V Ball Bearing Long Shaft								
1 ½	3600	143T	230/460	1MB21211AA214AG3	+	905	84.0	55
2	3600	145T	230/460	1MB21211AA314AG3	+	1028	85.5	65
3	3600	182T	230/460	1MB21211CA114AG3	+	1123	86.5	88
5	3600	184T	230/460	1MB21211CA314AG3	+	1502	88.5	105
7 ½	3600	213T	230/460	1MB21212AA114AG3	+	1695	89.5	165
10	3600	215T	230/460	1MB21212AA214AG3	+	1965	90.2	173
15	3600	254T	230/460	1MB21212BA114AG3	+	2671	91.0	283
20	3600	256T	230/460	1MB21212BA214AG3	+	3296	91.0	308
2 Pole 230/460V Ball Bearing Short Shaft								
25	3600	284TS	230/460	1MB21212DA116AG3	+	4075	91.7	526
30	3600	286TS	230/460	1MB21212DA216AG3	+	4757	91.7	521
40	3600	324TS	230/460	1MB21213BA116AG3	+	6044	93.6	606
50	3600	326TS	230/460	1MB21213BA216AG3	+	7708	93.6	615
60	3600	364TS	230/460	1MB21213DA116AG3	+	9349	93.6	790
75	3600	365TS	230/460	1MB21213DA216AG3	+	11400	94.1	900
100	3600	405TS	230/460	1MB21214BA216AG3	+	16053	94.1	1020
2 Pole 460V Ball Bearing Short Shaft								
125	3600	444TS	460	1MB21214DA112AG3		19573	95.0	1450
150	3600	445TS	460	1MB21214DA212AG3	+	24048	95.0	1611
200	3600	447TS	460	1MB21214DA312AG3	+	30713	95.4	2250
250	3600	449TS	460	1MB21214DA512AG3		37573	95.8	2300
300	3600	449TS	460	1MB21214DA612AG3		55226	95.8	2300

NEMA Premium is a certification mark of the National Electrical Manufacturer's Association

XP100 | Eff: NEMA Premium | Foot Mounted | Division 1, Class I, Groups C & D, Class II, Groups F & G

Power HP	Speed RPM	NEMA Frame	Voltage	Base Part Number	Stock	List Price	Eff %	Weight (lbs)
4 Pole 230/460V Ball Bearing Long Shaft								
1	1800	143T	230/460	1MB21211AB214AG3	+	862	85.5	77
1 ½	1800	145T	230/460	1MB21211AB314AG3	+	927	86.5	88
2	1800	145T	230/460	1MB21211AB414AG3	+	990	86.5	88
3	1800	182T	230/460	1MB21211CB114AG3	+	1115	89.5	110
5	1800	184T	230/460	1MB21211CB314AG3	+	1366	89.5	125
7 ½	1800	213T	230/460	1MB21212AB114AG3	+	1680	91.7	185
10	1800	215T	230/460	1MB21212AB214AG3	+	1995	91.7	187
15	1800	254T	230/460	1MB21212BB114AG3	+	2623	92.4	303
20	1800	256T	230/460	1MB21212BB214AG3	+	3252	93.0	340
25	1800	284T	230/460	1MB21212CB116AG3	+	3912	93.6	501
30	1800	286T	230/460	1MB21212CB216AG3	+	4546	93.6	521
40	1800	324T	230/460	1MB21213AB116AG3	+	5813	94.1	653
50	1800	326T	230/460	1MB21213AB216AG3	+	7081	94.5	695
60	1800	364T	230/460	1MB21213CB116AG3	+	9248	95.0	890
75	1800	365T	230/460	1MB21213CB216AG3	+	11369	95.4	960
100	1800	405T	230/460	1MB21214AB216AG3	+	14902	95.4	1115
4 Pole 460V Ball Bearing Long Shaft								
125	1800	B444T	460	1MB21214EB112AG3	+	18281	95.4	1621
150	1800	B445T	460	1MB21214EB212AG3	+	21783	95.8	1896
200	1800	B447T	460	1MB21214EB312AG3	+	26840	96.2	2276
250	1800	B449T	460	1MB21214EB512AG3	+	32273	96.2	2453
300	1800	B449T	460	1MB21214EB612AG3	+	41475	96.2	2315
4 Pole 460V Ball Bearing Short Shaft								
125	1800	444TS	460	1MB21214DB112AG3	+	18281	95.4	1596
150	1800	445TS	460	1MB21214DB212AG3	+	21783	95.8	1706
200	1800	447TS	460	1MB21214DB312AG3	+	26840	96.2	2250
250	1800	449TS	460	1MB21214DB512AG3	+	32273	96.2	2453
300	1800	449TS	460	1MB21214DB612AG3	+	41475	96.2	2315
4 Pole 460V Roller Bearing Long Shaft								
125	1800	444T	460	1MB21214CB112AG3	+	18889	95.4	1659
150	1800	445T	460	1MB21214CB212AG3	+	22391	95.8	1934
200	1800	447T	460	1MB21214CB312AG3	+	27448	96.2	2314
250	1800	449T	460	1MB21214CB512AG3	+	32881	96.2	2453
300	1800	449T	460	1MB21214CB612AG3	+	42083	96.2	2350

Voltage code "1-4" - Suitable for 208V

NEMA Premium is a certification mark of the National Electrical Manufacturer's Association

XP100 | Eff: NEMA Premium | Foot Mounted | Division 1, Class I, Groups C & D, Class II, Groups F & G

Power HP	Speed RPM	NEMA Frame	Voltage	Base Part Number	Stock	List Price	Eff %	Weight (lbs)
6 Pole 230/460V Ball Bearing Long Shaft								
1	1200	145T	230/460	1MB21211AC314AG3	+	1014	82.5	88
1.5	1200	182T	230/460	1MB21211CC114AG3	+	1106	87.5	105
2	1200	184T	230/460	1MB21211CC314AG3	+	1249	88.5	125
3	1200	213T	230/460	1MB21212AC114AG3	+	1522	89.5	173
5	1200	215T	230/460	1MB21212AC214AG3	+	2171	89.5	180
7.5	1200	254T	230/460	1MB21212BC114AG3	+	2627	91.0	285
10	1200	256T	230/460	1MB21212BC214AG3	+	3188	91.0	308
15	1200	284T	230/460	1MB21212CC116AG3	+	4415	91.7	481
20	1200	286T	230/460	1MB21212CC216AG3	+	5387	91.7	506
25	1200	324T	230/460	1MB21213AC116AG3	+	6500	93.0	713
30	1200	326T	230/460	1MB21213AC216AG3	+	7518	93.0	678
40	1200	364T	230/460	1MB21213CC116AG3	+	9692	94.1	835
50	1200	365T	230/460	1MB21213CC216AG3	+	11191	94.1	870
60	1200	404T	230/460	1MB21214AC116AG3	+	12420	94.5	1055
75	1200	405T	230/460	1MB21214AC216AG3	+	14263	94.5	1025
200	1200	B449T	460	1MB21214EC512AG3		31151	95.8	2440
6 Pole 460V Roller Bearing Long Shaft								
100	1200	444T	230/460	1MB21214CC116AG3	+	20680	95.0	1551
125	1200	445T	460	1MB21214CC212AG3	+	23252	95.0	1771
150	1200	447T	460	1MB21214CC312AG3	+	26725	95.8	2029
200	1200	449T	460	1MB21214CC512AG3	+	31759	95.8	2450
8 Pole 230/460V Ball Bearing Long Shaft								
1	900	182T	230/460	1MB21211CD114AG3	+	1874	81.5	100
1.5	900	184T	230/460	1MB21211CD314AG3	+	2206	82.5	125
2	900	213T	230/460	1MB21212AD114AG3	+	2639	84.0	161
3	900	215T	230/460	1MB21212AD214AG3	+	3170	85.5	173
5	900	254T	230/460	1MB21212BD114AG3	+	3616	86.5	270
7.5	900	256T	230/460	1MB21212BD214AG3		4131	87.5	300
10	900	284T	230/460	1MB21212CD116AG3		5124	90.2	486
15	900	286T	230/460	1MB21212CD216AG3		6574	91.0	531
20	900	324T	230/460	1MB21213AD116AG3		8482	91.0	636
25	900	326T	230/460	1MB21213AD216AG3		9885	91.0	683
30	900	364T	230/460	1MB21213CD116AG3		10420	91.7	860
40	900	365T	230/460	1MB21213CD216AG3		10319	91.7	940
50	900	404T	230/460	1MB21214AD116AG3		15978	92.4	1050
60	900	405T	230/460	1MB21214AD216AG3		18166	92.4	1050
8 Pole 460V Roller Bearing Long Shaft								
75	900	444T	230/460	1MB21214CD116AG3		22527	93.6	1551
100	900	445T	230/460	1MB21214CD216AG3		23716	94.1	1770
125	900	447T	460	1MB21214CD312AG3		32404	94.1	2029
150	900	449T	460	1MB21214CD512AG3		36954	94.1	2508
200	900	449T	460	1MB21214CD612AG3		39665	94.5	2450

NEMA Premium is a certification mark of the National Electrical Manufacturer's Association

XP100 | Eff: NEMA Premium | Division 1, Class I, Groups C & D, Class II, Groups F & G

C-Face Vertical Mount with Drip Cover

Power HP	Speed RPM	NEMA Frame	Voltage	Base Part Number	Stock	List Price	Eff %	Weight (lbs)
2 Pole 230/460V Ball Bearing Long Shaft								
1 ½	3600	143TC	230/460	1MB21211AA216LG3	+	1119	84.0	55
2	3600	145TC	230/460	1MB21211AA316LG3	+	1242	85.5	65
3	3600	182TC	230/460	1MB21211CA116LG3	+	1360	86.5	88
5	3600	184TC	230/460	1MB21211CA316LG3	+	1739	88.5	105
7 ½	3600	213TC	230/460	1MB21212AA116LG3	+	1934	89.5	165
10	3600	215TC	230/460	1MB21212AA216LG3	+	2204	90.2	173
15	3600	254TC	230/460	1MB21212BA116LG3	+	2989	91.0	283
20	3600	256TC	230/460	1MB21212BA216LG3	+	3614	91.0	308
4 Pole 230/460V Ball Bearing Long Shaft								
1	1800	143TC	230/460	1MB21211AB216LG3	+	1076	85.5	77
1 ½	1800	145TC	230/460	1MB21211AB316LG3	+	1141	86.5	88
2	1800	145TC	230/460	1MB21211AB416LG3	+	1204	86.5	88
3	1800	182TC	230/460	1MB21211CB116LG3	+	1352	89.5	110
5	1800	184TC	230/460	1MB21211CB316LG3	+	1603	89.5	125
7 ½	1800	213TC	230/460	1MB21212AB116LG3	+	1919	91.7	185
10	1800	215TC	230/460	1MB21212AB216LG3	+	2234	91.7	187
15	1800	254TC	230/460	1MB21212BB116LG3	+	2941	92.4	303
20	1800	256TC	230/460	1MB21212BB216LG3	+	3570	93.0	340
6 Pole 230/460V Ball Bearing Long Shaft								
1	1200	145TC	230/460	1MB21211AC316LG3	+	1228	82.5	88
1 ½	1200	182TC	230/460	1MB21211CC116LG3	+	1343	87.5	105
2	1200	184TC	230/460	1MB21211CC316LG3	+	1486	88.5	125
3	1200	213TC	230/460	1MB21212AC116LG3	+	1761	89.5	173
5	1200	215TC	230/460	1MB21212AC216LG3	+	2410	89.5	180
7 ½	1200	254TC	230/460	1MB21212BC116LG3	+	2945	91.0	285
10	1200	256TC	230/460	1MB21212BC216LG3	+	3506	91.0	308
15	1200	284TC	230/460	1MB21212CC116LG3		5521	91.7	481
20	1200	286TC	230/460	1MB21212CC216LG3		6493	91.7	506
8 Pole 230/460V Ball Bearing Long Shaft								
1	900	182TC	230/460	1MB21211CD116LG3		2111	81.5	100
1 ½	900	184TC	230/460	1MB21211CD316LG3		2443	82.5	125
2	900	213TC	230/460	1MB21212AD116LG3		2878	84.0	161
3	900	215TC	230/460	1MB21212AD216LG3		3409	85.5	173
5	900	254TC	230/460	1MB21212BD116LG3		3934	86.5	270
7 ½	900	256TC	230/460	1MB21212BD216LG3		4449	87.5	300

Voltage code "1-4" - Suitable for 208V

NEMA Premium is a certification mark of the National Electrical Manufacturer's Association

XP100 | Eff: NEMA Premium | Foot Mounted | 575V

Division 1, Class I, Groups C & D, Class II, Groups F & G

Power HP	Speed RPM	NEMA Frame	Voltage	Base Part Number	Stock	List Price	Eff %	Weight (lbs)
2 Pole 575V Ball Bearing Long Shaft								
1 ½	3600	143T	575	1MB21211AA213AG3		905	84.0	55
2	3600	145T	575	1MB21211AA313AG3		1028	85.5	65
3	3600	182T	575	1MB21211CA113AG3		1123	86.5	88
5	3600	184T	575	1MB21211CA313AG3		1502	88.5	105
7 ½	3600	213T	575	1MB21212AA113AG3		1695	89.5	165
10	3600	215T	575	1MB21212AA213AG3		1965	90.2	173
15	3600	254T	575	1MB21212BA113AG3		2671	91.0	283
20	3600	256T	575	1MB21212BA213AG3		3296	91.0	308
2 Pole 575V Ball Bearing Short Shaft								
25	3600	284TS	575	1MB21212DA113AG3		4075	91.7	526
30	3600	286TS	575	1MB21212DA213AG3		4757	91.7	521
40	3600	324TS	575	1MB21213BA113AG3		6044	93.6	606
50	3600	326TS	575	1MB21213BA213AG3		7708	93.6	615
60	3600	364TS	575	1MB21213DA113AG3		9349	93.6	790
75	3600	365TS	575	1MB21213DA213AG3		11400	94.1	900
100	3600	405TS	575	1MB21214BA213AG3		16053	94.1	1020
125	3600	444TS	575	1MB21214DA113AG3		19573	95.0	1450
150	3600	445TS	575	1MB21214DA213AG3		24048	95.0	1611
200	3600	447TS	575	1MB21214DA313AG3		30713	95.4	2250
250	3600	449TS	575	1MB21214DA513AG3		37573	95.8	2300
300	3600	449TS	575	1MB21214DA613AG3		55226	95.8	2300
4 Pole 575V Ball Bearing Long Shaft								
1	1800	143T	575	1MB21211AB213AG3	+	862	85.5	77
1 ½	1800	145T	575	1MB21211AB313AG3	+	927	86.5	88
2	1800	145T	575	1MB21211AB413AG3	+	990	86.5	88
3	1800	182T	575	1MB21211CB113AG3		1115	89.5	110
5	1800	184T	575	1MB21211CB313AG3	+	1366	89.5	125
7 ½	1800	213T	575	1MB21212AB113AG3		1680	91.7	185
10	1800	215T	575	1MB21212AB213AG3	+	1995	91.7	187
15	1800	254T	575	1MB21212BB113AG3		2623	92.4	303
20	1800	256T	575	1MB21212BB213AG3	+	3252	93.0	340
25	1800	284T	575	1MB21212CB113AG3		3912	93.6	501
30	1800	286T	575	1MB21212CB213AG3	+	4546	93.6	521
40	1800	324T	575	1MB21213AB113AG3		5813	94.1	653
50	1800	326T	575	1MB21213AB213AG3	+	7081	94.5	695
60	1800	364T	575	1MB21213CB113AG3		9248	95.0	890
75	1800	365T	575	1MB21213CB213AG3	+	11369	95.4	960
100	1800	405T	575	1MB21214AB213AG3	+	14902	95.4	1115

NEMA Premium is a certification mark of the National Electrical Manufacturer's Association

XP100 | Eff: NEMA Premium | Foot Mounted | 575V

Division 1, Class I, Groups C & D, Class II, Groups F & G

Power HP	Speed RPM	NEMA Frame	Voltage	Base Part Number	Stock	List Price	Eff %	Weight (lbs)
4 Pole 575V Ball Bearing Long Shaft								
125	1800	B444T	575	1MB21214EB113AG3	+	18281	95.4	1621
150	1800	B445T	575	1MB21214EB213AG3	+	21783	95.8	1896
200	1800	B447T	575	1MB21214EB313AG3	+	26840	96.2	2276
250	1800	B449T	575	1MB21214EB513AG3	+	32273	96.2	2453
300	1800	B449T	575	1MB21214EB613AG3	+	41475	96.2	2315
4 Pole 575V Ball Bearing Short Shaft								
125	1800	444TS	575	1MB21214DB113AG3		18281	95.4	1596
150	1800	445TS	575	1MB21214DB213AG3		21783	95.8	1706
200	1800	447TS	575	1MB21214DB313AG3		26840	96.2	2250
250	1800	449TS	575	1MB21214DB513AG3		32273	96.2	2453
300	1800	449TS	575	1MB21214DB613AG3		41475	96.2	2315
4 Pole 575V Roller Bearing Long Shaft								
125	1800	444T	575	1MB21214CB113AG3		18889	95.4	1659
150	1800	445T	575	1MB21214CB213AG3	+	22391	95.8	1934
200	1800	447T	575	1MB21214CB313AG3		27448	96.2	2314
250	1800	449T	575	1MB21214CB513AG3		32881	96.2	2453
300	1800	449T	575	1MB21214CB613AG3		42083	96.2	2350
6 Pole 575V Ball Bearing Long Shaft								
1	1200	145T	575	1MB21211AC313AG3		1014	82.5	88
1 ½	1200	182T	575	1MB21211CC113AG3		1106	87.5	105
2	1200	184T	575	1MB21211CC313AG3		1249	88.5	125
3	1200	213T	575	1MB21212AC113AG3		1522	89.5	173
5	1200	215T	575	1MB21212AC213AG3		2171	89.5	180
7 ½	1200	254T	575	1MB21212BC113AG3		2627	91.0	285
10	1200	256T	575	1MB21212BC213AG3		3188	91.0	308
15	1200	284T	575	1MB21212CC113AG3		4415	91.7	481
20	1200	286T	575	1MB21212CC213AG3		5387	91.7	506
25	1200	324T	575	1MB21213AC113AG3		6500	93.0	713
30	1200	326T	575	1MB21213AC213AG3		7518	93.0	678
40	1200	364T	575	1MB21213CC113AG3		9692	94.1	835
50	1200	365T	575	1MB21213CC213AG3		11191	94.1	870
60	1200	404T	575	1MB21214AC113AG3		12420	94.5	1055
75	1200	405T	575	1MB21214AC213AG3		14263	94.5	1025
200	1200	B449T	575	1MB21214EC513AG3		31151	95.8	2440
6 Pole 575V Ball Bearing Short Shaft								
250	1200	449TS	575	1MB21214DC613AG3		38095	95.8	2400
6 Pole 575V Roller Bearing Long Shaft								
100	1200	444T	575	1MB21214CC113AG3		20680	95.0	1551
125	1200	445T	575	1MB21214CC213AG3		23252	95.0	1771
150	1200	447T	575	1MB21214CC313AG3		26725	95.8	2029
200	1200	449T	575	1MB21214CC513AG3		31759	95.8	2450

NEMA Premium is a certification mark of the National Electrical Manufacturer's Association

XP100 | Eff: NEMA Premium | Foot Mounted | 575V

Division 1, Class I, Groups C & D, Class II, Groups F & G

Power HP	Speed RPM	NEMA Frame	Voltage	Base Part Number	Stock	List Price	Eff %	Weight (lbs)
8 Pole 575V Ball Bearing Long Shaft								
1	900	182T	575	1MB21211CD113AG3		1874	81.5	100
1 ½	900	184T	575	1MB21211CD313AG3		2206	82.5	125
2	900	213T	575	1MB21212AD113AG3		2639	84.0	161
3	900	215T	575	1MB21212AD213AG3		3170	85.5	173
5	900	254T	575	1MB21212BD113AG3		3616	86.5	270
7 ½	900	256T	575	1MB21212BD213AG3		4131	87.5	300
10	900	284T	575	1MB21212CD113AG3		5124	90.2	486
15	900	286T	575	1MB21212CD213AG3		6574	91.0	531
20	900	324T	575	1MB21213AD113AG3		8482	91.0	636
25	900	326T	575	1MB21213AD213AG3		9885	91.0	683
30	900	364T	575	1MB21213CD113AG3		10420	91.7	860
40	900	365T	575	1MB21213CD213AG3		10319	91.7	940
50	900	404T	575	1MB21214AD113AG3		15978	92.4	1050
60	900	405T	575	1MB21214AD213AG3		18166	92.4	1050
8 Pole 575V Roller Bearing Long Shaft								
75	900	444T	575	1MB21214CD113AG3		22527	93.6	1551
100	900	445T	575	1MB21214CD213AG3		23716	94.1	1770
125	900	447T	575	1MB21214CD313AG3		32404	94.1	2029
150	900	449T	575	1MB21214CD513AG3		36954	94.1	2508
200	900	449T	575	1MB21214CD613AG3		39665	94.5	2450

NEMA Premium is a certification mark of the National Electrical Manufacturer's Association

3.2.3.2. XP100 ID1



XP100 | Eff: NEMA Premium | Foot Mounted

Division 1, Class I, Group D

Power HP	Speed RPM	NEMA Frame	Voltage	Base Part Number	Stock	List Price	Eff %	Weight (lbs)
2 Pole 230/460V Ball Bearing Long Shaft								
1 ½	3600	143T	230/460	1MB22211AA214AA3		869	84.0	55
2	3600	145T	230/460	1MB22211AA314AA3		987	85.5	65
3	3600	182T	230/460	1MB22211CA114AA3	+	1078	86.5	88
5	3600	184T	230/460	1MB22211CA314AA3	+	1442	88.5	105
7 ½	3600	213T	230/460	1MB22212AA114AA3	+	1627	89.5	165
10	3600	215T	230/460	1MB22212AA214AA3	+	1886	90.2	173
15	3600	254T	230/460	1MB22212BA114AA3		2564	91.0	283
20	3600	256T	230/460	1MB22212BA214AA3	+	3164	91.0	308
2 Pole 230/460V Ball Bearing Short Shaft								
25	3600	284TS	230/460	1MB22212DA116AA3	+	3526	91.7	530
30	3600	286TS	230/460	1MB22212DA216AA3	+	4110	91.7	525
40	3600	324TS	230/460	1MB22213BA116AA3	+	5211	93.6	615
50	3600	326TS	230/460	1MB22213BA216AA3	+	6636	93.6	615
60	3600	364TS	230/460	1MB22213DA116AA3		8675	93.6	790
75	3600	365TS	230/460	1MB22213DA216AA3		10490	94.1	900
100	3600	405TS	230/460	1MB22214BA216AA3		14644	94.1	1020
2 Pole 460V Ball Bearing Short Shaft								
125	3600	444TS	460	1MB22214DA112AA3		17760	95.0	1450
150	3600	445TS	460	1MB22214DA212AA3		21743	95.0	1611
200	3600	447TS	460	1MB22214DA312AA3		27361	95.4	2250
250	3600	449TS	460	1MB22214DA512AA3		32434	95.8	2300
300	3600	449TS	460	1MB22214DA612AA3		41503	95.8	2300

NEMA Premium is a certification mark of the National Electrical Manufacturer's Association

XP100 | Eff: NEMA Premium | Foot Mounted

Division 1, Class I, Group D

Power HP	Speed RPM	NEMA Frame	Voltage	Base Part Number	Stock	List Price	Eff %	Weight (lbs)
4 Pole 230/460V Ball Bearing Long Shaft								
1	1800	143T	230/460	1MB22211AB214AA3		828	85.5	77
1 ½	1800	145T	230/460	1MB22211AB314AA3		890	86.5	88
2	1800	145T	230/460	1MB22211AB414AA3		950	86.5	88
3	1800	182T	230/460	1MB22211CB114AA3	+	1070	89.5	110
5	1800	184T	230/460	1MB22211CB314AA3	+	1311	89.5	125
7 ½	1800	213T	230/460	1MB22212AB114AA3	+	1613	91.7	185
10	1800	215T	230/460	1MB22212AB214AA3	+	1915	91.7	187
15	1800	254T	230/460	1MB22212BB114AA3	+	2518	92.4	303
20	1800	256T	230/460	1MB22212BB214AA3	+	3122	93.0	340
25	1800	284T	230/460	1MB22212CB116AA3	+	3396	93.6	501
30	1800	286T	230/460	1MB22212CB216AA3	+	3940	93.6	521
40	1800	324T	230/460	1MB22213AB116AA3	+	5028	94.1	653
50	1800	326T	230/460	1MB22213AB216AA3	+	6116	94.5	687
60	1800	364T	230/460	1MB22213CB116AA3	+	8611	95.0	890
75	1800	365T	230/460	1MB22213CB216AA3	+	10498	95.4	960
100	1800	405T	230/460	1MB22214AB216AA3	+	13641	95.4	1115
4 Pole 460V Ball Bearing Long Shaft								
125	1800	B444T	460	1MB22214EB112AA3	+	16646	95.4	1621
150	1800	B445T	460	1MB22214EB212AA3	+	19761	95.8	1896
200	1800	B447T	460	1MB22214EB312AA3		23993	96.2	2276
250	1800	B449T	460	1MB22214EB512AA3		27954	96.2	2453
300	1800	B449T	460	1MB22214EB612AA3		31274	96.2	2340
4 Pole 460V Roller Bearing Long Shaft								
125	1800	444T	460	1MB22214CB112AA3		17254	95.4	1659
150	1800	445T	460	1MB22214CB212AA3		20369	95.8	1934
200	1800	447T	460	1MB22214CB312AA3		24601	96.2	2314
250	1800	449T	460	1MB22214CB512AA3		28562	96.2	2453
300	1800	449T	460	1MB22214CB612AA3		31882	96.2	2350

Voltage code "1-4" - Suitable for 208V

NEMA Premium is a certification mark of the National Electrical Manufacturer's Association

XP100 | Eff: NEMA Premium | Foot Mounted

Division 1, Class I, Group D

Power HP	Speed RPM	NEMA Frame	Voltage	Base Part Number	Stock	List Price	Eff %	Weight (lbs)
6 Pole 230/460V Ball Bearing Long Shaft								
1	1200	145T	230/460	1MB22211AC314AA3		973	82.5	88
1 ½	1200	182T	230/460	1MB22211CC114AA3		1062	87.5	105
2	1200	184T	230/460	1MB22211CC314AA3		1199	88.5	125
3	1200	213T	230/460	1MB22212AC114AA3		1461	89.5	173
5	1200	215T	230/460	1MB22212AC214AA3		2084	89.5	180
7 ½	1200	254T	230/460	1MB22212BC114AA3		2522	91.0	285
10	1200	256T	230/460	1MB22212BC214AA3		3060	91.0	308
15	1200	284T	230/460	1MB22212CC116AA3		3814	91.7	481
20	1200	286T	230/460	1MB22212CC216AA3		4638	91.7	506
25	1200	324T	230/460	1MB22213AC116AA3		5584	93.0	713
30	1200	326T	230/460	1MB22213AC216AA3		6449	93.0	678
40	1200	364T	230/460	1MB22213CC116AA3		8296	94.1	835
50	1200	365T	230/460	1MB22213CC216AA3		9567	94.1	870
60	1200	404T	230/460	1MB22214AC116AA3		11445	94.5	1055
75	1200	405T	230/460	1MB22214AC216AA3		13033	94.5	1025
100	1200	B444T	230/460	1MB22214EC116AA3		18181	95.0	1513
6 Pole 460V Ball Bearing Long Shaft								
125	1200	B445T	460	1MB22214EC212AA3		20405	95.0	1733
150	1200	B447T	460	1MB22214EC312AA3		23447	95.8	1991
200	1200	B449T	460	1MB22214EC512AA3		27555	95.8	2440
6 Pole 460V Roller Bearing Long Shaft								
100	1200	444T	230/460	1MB22214CC116AA3		18789	95.0	1551
125	1200	445T	460	1MB22214CC212AA3		21013	95.0	1771
150	1200	447T	460	1MB22214CC312AA3		24055	95.8	2029
200	1200	449T	460	1MB22214CC512AA3		28163	95.8	2450

Voltage code "1-4" - Suitable for 208V

NEMA Premium is a certification mark of the National Electrical Manufacturer's Association

XP100 | Eff: NEMA Premium | Foot Mounted | 575V

Division 1, Class I, Group D

Power HP	Speed RPM	NEMA Frame	Voltage	Base Part Number	Stock	List Price	Eff %	Weight (lbs)
4 Pole 575V Ball Bearing Long Shaft								
1	1800	143T	575	1MB22211AB213AA3		828	85.5	77
1 ½	1800	145T	575	1MB22211AB313AA3		890	86.5	88
2	1800	145T	575	1MB22211AB413AA3		950	86.5	88
3	1800	182T	575	1MB22211CB113AA3		1070	89.5	110
5	1800	184T	575	1MB22211CB313AA3		1311	89.5	125
7 ½	1800	213T	575	1MB22212AB113AA3		1613	91.7	185
10	1800	215T	575	1MB22212AB213AA3		1915	91.7	187
15	1800	254T	575	1MB22212BB113AA3		2518	92.4	303
20	1800	256T	575	1MB22212BB213AA3		3122	93.0	340
25	1800	284T	575	1MB22212CB113AA3		3396	93.6	501
30	1800	286T	575	1MB22212CB213AA3		3940	93.6	521
40	1800	324T	575	1MB22213AB113AA3		5028	94.1	653
50	1800	326T	575	1MB22213AB213AA3		6116	94.5	687
60	1800	364T	575	1MB22213CB113AA3		8611	95.0	890
75	1800	365T	575	1MB22213CB213AA3		10498	95.4	960
100	1800	405T	575	1MB22214AB213AA3		13641	95.4	1115
125	1800	B444T	575	1MB22214EB113AA3		16646	95.4	1621
150	1800	B445T	575	1MB22214EB213AA3		19761	95.8	1896
200	1800	B447T	575	1MB22214EB313AA3		23993	96.2	2276
250	1800	B449T	575	1MB22214EB513AA3		27954	96.2	2453
300	1800	B449T	575	1MB22214EB613AA3		31274	96.2	2340
4 Pole 575V Roller Bearing Long Shaft								
125	1800	444T	575	1MB22214CB113AA3		17254	95.4	1659
150	1800	445T	575	1MB22214CB213AA3		20369	95.8	1934
200	1800	447T	575	1MB22214CB313AA3		25751	96.2	2314
250	1800	449T	575	1MB22214CB513AA3		28562	96.2	2453
300	1800	449T	575	1MB22214CB613AA3		31882	96.2	2350

Voltage code "1-4" - Suitable for 208V

NEMA Premium is a certification mark of the National Electrical Manufacturer's Association

3.2.3.3. XP100 JP Frame

XP100 | Eff: NEMA Premium | C-Face Foot Mount with JP Shaft

Division 1, Class I, Groups C & D, Class II, Groups F & G

Power HP	Speed RPM	NEMA Frame	Voltage	Base Part Number	Stock	List Price	Eff %	Weight (lbs)
3	1800	182JP	230/460	1MB21211FB314WG3	+	1719	89.5	110
5	1800	184JP	230/460	1MB21211FB414WG3	+	1970	89.5	125
7 ½	1800	213JP	230/460	1MB21212FB314EG3		3101	91.7	185
10	1800	215JP	230/460	1MB21212FB414EG3		3416	91.7	187

Voltage code "1-4" - Suitable for 208V

NEMA Premium is a certification mark of the National Electrical Manufacturer's Association

XP100 ID1 | Eff: NEMA Premium | C-Face Foot Mount with JP Shaft

Division 1, Class I, Groups D

Power HP	Speed RPM	NEMA Frame	Voltage	Base Part Number	Stock	List Price	Eff %	Weight (lbs)
3	1800	182JP	230/460	1MB22211FB314WA3		1377	89.5	110
5	1800	184JP	230/460	1MB22211FB414WA3		1628	89.5	125
7.5	1800	213JP	230/460	1MB22212FB314EA3		2902	91.7	185
10	1800	215JP	230/460	1MB22212FB414EA3		3171	91.7	187

Voltage code "1-4" - Suitable for 208V

NEMA Premium is a certification mark of the National Electrical Manufacturer's Association

3.2.4. Definite Purpose Low Voltage NEMA Motors

Introduction

ABB Definite Purpose low voltage NEMA motors are designed and built to operate under harsh environments in the industry, including but not limited to petrochemical, pulp and paper mills and wastewater treatment. in-line pumps, booster, centrifugal and non-clog pumps, vertical turbine, mix flow, and propeller pumps are some of the many applications. Pump motors are designed to meet or exceed the NEMA Premium® efficiency (MG1 Table 12-12) as well as the most stringent industry standards API610 (LP100) and IEEE 841 where applicable. DP200 HPS motors use the SD200 as a base with added features (Provisions for Bearing RTDs, Provisions for Vibration detectors, and Insulated NDE bearing) that are key in the Horizontal Pump Systems motors. SD10 MS motors are energy efficient motors built with the same characteristics of our Severe Duty line. A wide selection of options, among them bearing isolator and ceramic bearings on drive end, extra high thrust and Non-Reverse Ratchet for LP100 motors, make these motors suitable for almost any requirement. The construction of these motors is backed by its three-year warranty and 5 years when ordered with IEEE841 features.



Performance Specification

		Pump Motors		Multi-speed
		VSS Vertical Solid Shaft		One Winding Variable
		LP100	HP100	SD10 MS
HP Range	3600 RPM	3-100 HP		1-250HP 1800 / 900
	1800 RPM			
	1200 RPM	3-250 HP		
Frame Size	140T - 500	180LP- 440LP	180H - 440HP	143T-449T
Standard Voltage (3~ 60 Hz)	230V/460V	FS 180-250		-
	460V	FS 280-440		FS 143-449
	575V	FS 180-440		FS 143-449
Efficiency	NEMA Premium® (MG1-Table 12-12)	3-300 HP		-
	Energy Efficient (MG 1-Table 12-11)	-		FS 143-449
Service Factor	1.15 @ 40°C	FS 180-440		-
	1.00 @ 40°C	-		FS 143-449
Insulation	Non-Hygroscopic	Class F		Class F
Temperature Rise	Class B	@ 1.0SF		@ 1.0SF
	Class F	@ 1.15SF		@ 1.15SF
Conduit Box (Oversized)	Oversized	Cast Iron		Cast Iron
Fan Cover		Cast Iron		Cast Iron
Cooling Fan	Bi-Directional	Polypropylene		Polypropylene
Rotor	Die Cast Aluminum	FS 180-440		FS 143-449
Ingress Protection	NEMA	IP55		IP54
Hazardous Location	Gas	CL 1, Div 2 Gr. A, B, C or D Temp Code T3		-
Inverter Duty ⁵	Variable Torque VT 20:1	FS 180-440		-
	Constant Torque CT 4:1	FS 180-440		-
	Constant Torque CT 2:1	-		-

Frame and end shields

Definite purpose motors feature cast iron frame, end shields and an easy to access, diagonally split, oversize terminal box; the terminal box is provided with a neoprene gasket and includes a heavy-duty ground lug and non-wicking clearly and permanently marked leads. These characteristics, its zinc-plated hardware, epoxy paint and stainless-steel nameplate provide exceptional structural integrity and resistant to rust and corrosion and make them suitable for severe duty applications in harsh environments.

Rotor and stator windings

A unique offset rotor bar design provides improved efficiency, while larger bars and end rings reduce resistance for lower rotor losses. Each die cast aluminum rotor assembly is dynamically balanced with half key for extended bearing life and includes a high-strength carbon steel (C1045) shaft for maximum rotor performance.

The stator is manufactured with premium electrical C5 grade steel lamination and copper electrical magnet wire that reduce losses.

Insulation

The proprietary Class F non-hygroscopic insulation system, NEMA Class B temperature rise, provides an extra margin of thermal life. The varnish system application ensures maximum wire penetration to provide protection from moisture, corrosion and electrical shock. This insulation system meets or exceeds NEMA MG1 Part 31 making the motors suitable for variable speed drives in constant torque (4:1) and variable torque (20:1). All windings are tested for CIV.

Cooling system

A non-sparking, bi-directional fan is locked and keyed to the shaft. Its low-inertia design reduces windage losses, improves airflow, reduces noise and provides dependable cooling. Metal sheet fan covers are provided for all frames sizes.

Bearings

Definite purpose motors are provided with single shielded bearings, HP100 (DE and NDE) and LP100 (DE) include regreasable open ball bearings for up to 250HP and 250LP frames, The LP100 opposite drive end features a duplex angular contact thrust bearing, across all frame sizes, depending on the arrangement the motor can provide high thrust or up to 175% extra high thrust.

3.2.4.1. Vertical Solid Shaft – LP100

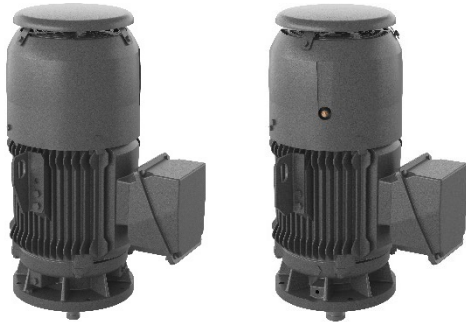

LP100 | Eff: NEMA Premium | Vertical P-Base | NDE Thrust Bearing(s)

Power HP	Speed RPM	NEMA Frame	Voltage	Base Part Number	Stock	List Price	Rated Thrust (Lbs)			Eff %	Weight (lbs)
							Down Thrust	Up Thrust	Radial Thrust		
2 Pole 230/460V											
3	3600	182LP	230/460	1PC28321DA416TA3	+	1967	1087	1095	24	86.5	118
5	3600	184LP	230/460	1PC28321DA516TA3	+	2174	1075	1082	34	88.5	130
7 ½	3600	213LP	230/460	1PC28322AA516TA3	+	2609	1860	1880	40	89.5	188
10	3600	215LP	230/460	1PC28322AA616TA3	+	2922	1848	1868	50	90.2	202
15	3600	254LP	230/460	1PC28322BA516TA3	+	3366	1811	1843	75	91.0	309
20	3600	256LP	230/460	1PC28322BA616TA3	+	3778	1789	1824	92	91.0	337
2 Pole 460V											
25	3600	284LPH	460	1PC28322EA112TA3	+	5247	2541	2593	65	91.7	559
30	3600	286LPH	460	1PC28322EA412TA3	+	5567	2523	2578	78	91.7	591
40	3600	324LP	460	1PC28323AA512TA3	+	7423	2480	2551	98	93.6	784
50	3600	326LP	460	1PC28323AA612TA3	+	9095	2466	2535	105	93.6	799
60	3600	364LP	460	1PC28323CA512TA3	+	11320	2386	2495	152	93.6	836
75	3600	365LP	460	1PC28323CA612TA3	+	13799	2352	2465	175	94.1	877
100	3600	405LP	460	1PC28324AA612TA3	+	15824	2269	2406	230	94.1	1057
4 Pole 230/460V											
3	1800	182LP	230/460	1PC28321DB416TA3	+	1916	1361	1369	39	89.5	129
5	1800	184LP	230/460	1PC28321DB516TA3	+	2054	1351	1357	45	89.5	135
7 ½	1800	213LP	230/460	1PC28322AB516TA3	+	2599	2328	2351	66	91.7	212
10	1800	215LP	230/460	1PC28322AB616TA3	+	2924	2317	2338	73	91.7	220
15	1800	254LP	230/460	1PC28322BB516TA3	+	3495	2279	2309	95	92.4	315
20	1800	256LP	230/460	1PC28322BB616TA3	+	3982	2247	2281	120	93.0	342

Extra high thrust is available with option K21, refer to Technical Notes Section Bearing and Lubrication Table 6.2 for thrust values
 NEMA Premium is a certification mark of the National Electrical Manufacturer's Association

LP100 | Eff: NEMA Premium | Vertical P-Base | NDE Thrust Bearing(s)

Power HP	Speed RPM	NEMA Frame	Voltage	Base Part Number	Stock	List Price	Rated Thrust (Lbs)			Eff %	Weight (lbs)
							Down Thrust	Up Thrust	Radial Thrust		
4 Pole 460V											
25	1800	284LPH	460	1PC28322EB112TA3	+	5163	3172	3233	108	93.6	640
30	1800	286LPH	460	1PC28322EB412TA3	+	5808	3158	3217	116	93.6	649
40	1800	324LP	460	1PC28323AB512TA3	+	7198	3093	3179	140	94.1	848
50	1800	326LP	460	1PC28323AB612TA3	+	8446	3034	3135	180	94.5	957
60	1800	364LP	460	1PC28323CB512TA3	+	11264	2965	3097	214	95.0	885
75	1800	365LP	460	1PC28323CB612TA3	+	13843	2902	3046	255	95.4	948
100	1800	405LP	460	1PC28324AB612TA3	+	15980	2814	2976	303	95.4	1059
125	1800	444LP	460	1PC28324JB112TA3	+	19235	2670	2911	347	95.4	1429
150	1800	445LP	460	1PC28324JB212TA3		22459	2558	2835	417	95.8	1565
200	1800	447LP	460	1PC28324JB312TA3		28193	2361	2703	524	96.2	1843
250	1800	449LP	460	1PC28324JB512TA3		32755	2149	2571	638	96.2	2203
6 Pole 230/460V											
3	1200	213LP	230/460	1PC28322AC516TA3		2290	2702	2725	51	89.5	192
5	1200	215LP	230/460	1PC28322AC616TA3		2978	2685	2705	62	89.5	204
7 ½	1200	254LP	230/460	1PC28322BC516TA3		3548	2648	2680	84	91.0	294
10	1200	256LP	230/460	1PC28322BC616TA3		4006	2629	2659	98	91.0	310
15	1200	284LPH	230/460	1PC28322EC116TA3		5611	3682	3738	95	91.7	601
20	1200	286LPH	230/460	1PC28322EC416TA3		6815	3645	3705	120	91.7	656
6 Pole 460V											
25	1200	324LP	460	1PC28323AC512TA3		7726	3569	3665	155	93.0	884
30	1200	326LP	460	1PC28323AC612TA3		8636	3541	3640	172	93.0	920
40	1200	364LP	460	1PC28323CC512TA3		11091	3494	3605	186	94.1	822
50	1200	365LP	460	1PC28323CC612TA3		13076	3455	3565	208	94.1	855
60	1200	404LP	460	1PC28324AC512TA3		14165	3351	3500	274	94.5	1021
75	1200	405LP	460	1PC28324AC612TA3		16609	3290	3444	310	94.5	1088
100	1200	444LP	460	1PC28324JC112TA3		19867	3116	3364	353	95.0	1385
125	1200	445LP	460	1PC28324JC212TA3		25251	2946	3254	455	95.0	1565
150	1200	447LP	460	1PC28324JC312TA3		29844	2795	3161	529	95.8	1778
200	1200	449LP	460	1PC28324JC512TA3		32855	2515	2985	673	95.8	2204
250	1200	449LP	460	1PC28324JC612TA3		37395	2488	2904	679	95.8	2191

Add “-Z” at the end of the base part number, and short code “+K21”

NEMA Premium is a certification mark of the National Electrical Manufacturer's Association.

LP100 | Eff: NEMA Premium | Vertical P-Base | NDE Thrust Bearing(s) | 575V

Power HP	Speed RPM	NEMA Frame	Voltage	Base Part Number	Stock	List Price	Rated Thrust (Lbs)			Eff %	Weight (lbs)
							Down Thrust	Up Thrust	Radial Thrust		
2 Pole 575V											
3	3600	182LP	575	1PC28321DA413TA3		1967	1087	1095	24	86.5	118
5	3600	184LP	575	1PC28321DA513TA3		2174	1075	1082	34	88.5	130
7 ½	3600	213LP	575	1PC28322AA513TA3		2609	1860	1880	40	89.5	188
10	3600	215LP	575	1PC28322AA613TA3		2922	1848	1868	50	90.2	202
15	3600	254LP	575	1PC28322BA513TA3		3366	1811	1843	75	91.0	309
20	3600	256LP	575	1PC28322BA613TA3		3778	1789	1824	92	91.0	337
25	3600	284LPH	575	1PC28322EA113TA3		5247	2541	2593	65	91.7	559
30	3600	286LPH	575	1PC28322EA413TA3		5567	2523	2578	78	91.7	591
40	3600	324LP	575	1PC28323AA513TA3		7423	2480	2551	98	93.6	784
50	3600	326LP	575	1PC28323AA613TA3		9095	2466	2535	105	93.6	799
60	3600	364LP	575	1PC28323CA513TA3		11320	2386	2495	152	93.6	836
75	3600	365LP	575	1PC28323CA613TA3		13799	2352	2465	175	94.1	877
100	3600	405LP	575	1PC28324AA613TA3		15824	2269	2406	230	94.1	1057
4 Pole 575V											
3	1800	182LP	575	1PC28321DB413TA3		1916	1361	1369	39	89.5	129
5	1800	184LP	575	1PC28321DB513TA3		2054	1351	1357	45	89.5	135
7 ½	1800	213LP	575	1PC28322AB513TA3		2599	2328	2351	66	91.7	212
10	1800	215LP	575	1PC28322AB613TA3		2924	2317	2338	73	91.7	220
15	1800	254LP	575	1PC28322BB513TA3		3495	2279	2309	95	92.4	315
20	1800	256LP	575	1PC28322BB613TA3		3982	2247	2281	120	93.0	342
25	1800	284LPH	575	1PC28322EB113TA3		5163	3172	3233	108	93.6	640
30	1800	286LPH	575	1PC28322EB413TA3		5808	3158	3217	116	93.6	649
40	1800	324LP	575	1PC28323AB513TA3		7198	3093	3179	140	94.1	848
50	1800	326LP	575	1PC28323AB613TA3		8446	3034	3135	180	94.5	957
60	1800	364LP	575	1PC28323CB513TA3		11264	2965	3097	214	95.0	885
75	1800	365LP	575	1PC28323CB613TA3		13843	2902	3046	255	95.4	948
100	1800	405LP	575	1PC28324AB613TA3		15980	2814	2976	303	95.4	1059
125	1800	444LP	575	1PC28324JB113TA3		19235	2670	2911	347	95.4	1429
150	1800	445LP	575	1PC28324JB213TA3		22459	2558	2835	417	95.8	1565
200	1800	447LP	575	1PC28324JB313TA3		28193	2361	2703	524	96.2	1843
250	1800	449LP	575	1PC28324JB513TA3		32755	2149	2571	638	96.2	2203

Extra high thrust is available with option K21, refer to Technical Notes Section Bearing and Lubrication Table 6-2 for thrust values
 NEMA Premium is a certification mark of the National Electrical Manufacturer's Association

LP100 | Eff: NEMA Premium | Vertical P-Base | NDE Thrust Bearing(s) | 575V

Power HP	Speed RPM	NEMA Frame	Voltage	Base Part Number	Stock	List Price	Rated Thrust (Lbs)			Eff %	Weight (lbs)
							Down Thrust	Up Thrust	Radial Thrust		
6 Pole 575V											
3	1200	213LP	575	1PC28322AC513TA3		2290	2702	2725	51	89.5	192
5	1200	215LP	575	1PC28322AC613TA3		2978	2685	2705	62	89.5	204
7 ½	1200	254LP	575	1PC28322BC513TA3		3548	2648	2680	84	91.0	294
10	1200	256LP	575	1PC28322BC613TA3		4006	2629	2659	98	91.0	310
15	1200	284LPH	575	1PC28322EC113TA3		5611	3682	3738	95	91.7	601
20	1200	286LPH	575	1PC28322EC413TA3		6815	3645	3705	120	91.7	656
25	1200	324LP	575	1PC28323AC513TA3		7726	3569	3665	155	93.0	884
30	1200	326LP	575	1PC28323AC613TA3		8636	3541	3640	172	93.0	920
40	1200	364LP	575	1PC28323CC513TA3		11091	3494	3605	186	94.1	822
50	1200	365LP	575	1PC28323CC613TA3		13076	3455	3565	208	94.1	855
60	1200	404LP	575	1PC28324AC513TA3		14165	3351	3500	274	94.5	1021
75	1200	405LP	575	1PC28324AC613TA3		16609	3290	3444	310	94.5	1088
100	1200	444LP	575	1PC28324JC113TA3		19867	3116	3364	353	95.0	1385
125	1200	445LP	575	1PC28324JC213TA3		25251	2946	3254	455	95.0	1565
150	1200	447LP	575	1PC28324JC313TA3		29844	2795	3161	529	95.8	1778
200	1200	449LP	575	1PC28324JC513TA3		32855	2515	2985	673	95.8	2204
250	1200	449LP	575	1PC28324JC613TA3		37395	2488	2904	679	95.8	2191

Add “-Z” at the end of the base part number, and short code “+K21”

NEMA Premium is a certification mark of the National Electrical Manufacturer's Association

3.2.4.2. Vertical Solid Shaft – HP100

LP100 | Eff: NEMA Premium | Vertical P-Base | Ball Bearings

Power HP	Speed RPM	NEMA Frame	Voltage	Base Part Number	Stock	List Price	Rated Thrust (Lbs)			Eff %	Weight (lbs)
							Down Thrust	Up Thrust	Radial Thrust		
2 Pole 230/460V											
3	3600	182HP	230/460	1PC28221DA116TA3	+	1482	901	908	24	86.5	118
5	3600	184HP	230/460	1PC28221DA216TA3	+	2077	889	896	34	88.5	130
7 ½	3600	213HP	230/460	1PC28222AA316TA3	+	2504	1681	1699	40	89.5	188
10	3600	215HP	230/460	1PC28222AA416TA3	+	2805	1668	1688	52	90.2	202
15	3600	254HP	230/460	1PC28222BA316TA3	+	3234	1631	1664	76	91.0	309
20	3600	256HP	230/460	1PC28222BA416TA3	+	3536	1609	1643	94	91.0	337
2 Pole 460V											
25	3600	284HP	460	1PC28222CA312TA3	+	4425	1525	1567	66	91.7	454
30	3600	286HP	460	1PC28222CA412TA3	+	4790	1508	1552	78	91.7	486
40	3600	324HP	460	1PC28223AA312TA3	+	6576	1952	2025	106	93.6	674
50	3600	326HP	460	1PC28223AA412TA3	+	8249	1938	2007	114	93.6	689
60	3600	364HP	460	1PC28223CA312TA3	+	10498	2226	2345	153	93.6	817
75	3600	365HP	460	1PC28223CA412TA3	+	12977	2192	2314	175	94.1	857
100	3600	405HP	460	1PC28224AA412TA3	+	14695	2110	2255	230	94.1	1023
4 Pole 230/460V											
3	1800	182HP	230/460	1PC28221DB116TA3		1308	1126	1134	39	89.5	129
5	1800	184HP	230/460	1PC28221DB216TA3	+	1821	1116	1122	45	89.5	135
7 ½	1800	213HP	230/460	1PC28222AB316TA3	+	2495	2102	2123	66	91.7	211
10	1800	215HP	230/460	1PC28222AB416TA3	+	2807	2091	2111	75	91.7	220
15	1800	254HP	230/460	1PC28222BB316TA3	+	3354	2052	2082	97	92.4	315
20	1800	256HP	230/460	1PC28222BB416TA3	+	3823	2021	2052	122	93.0	342
4 Pole 460V											
25	1800	284HP	460	1PC28222CB312TA3	+	4957	1890	1940	109	93.6	535
30	1800	286HP	460	1PC28222CB412TA3	+	5576	1876	1923	117	93.6	544
40	1800	324HP	460	1PC28223AB312TA3	+	6642	2427	2514	153	94.1	737
50	1800	326HP	460	1PC28223AB412TA3		7876	2366	2468	196	94.5	846
60	1800	364HP	460	1PC28223CB312TA3		10442	2767	2908	215	95.0	865
75	1800	365HP	460	1PC28223CB412TA3	+	13020	2703	2856	255	95.4	928
100	1800	405HP	460	1PC28224AB412TA3	+	15265	2616	2786	304	95.4	1073
125	1800	444HP	460	1PC28224HB112TA3		18932	2985	3243	342	95.4	1419
150	1800	445HP	460	1PC28224HB212TA3		21839	2874	3166	411	95.8	1559
200	1800	447HP	460	1PC28224HB312TA3		27746	2678	3035	516	96.2	1854
250	1800	449HP	460	1PC28224HB512TA3		30397	2466	2903	631	96.2	2246

Extra high thrust is available with option K21, refer to Technical Notes Section Bearing and Lubrication Table 6-2 for thrust values
 NEMA Premium is a certification mark of the National Electrical Manufacturer's Association.

LP100 | Eff: NEMA Premium | Vertical P-Base | Ball Bearings

Power HP	Speed RPM	NEMA Frame	Voltage	Base Part Number	Stock	List Price	Rated Thrust (Lbs)			Eff %	Weight (lbs)
							Down Thrust	Up Thrust	Radial Thrust		
6 Pole 230/460V											
3	1200	213HP	230/460	1PC28222AC316TA3		2029	2442	2413	51	89.5	192
5	1200	215HP	230/460	1PC28222AC416TA3		2857	2426	2413	62	89.5	204
7 ½	1200	254HP	230/460	1PC28222BC316TA3		3406	2389	2413	86	91.0	294
10	1200	256HP	230/460	1PC28222BC416TA3		3848	2369	2399	100	91.0	310
15	1200	284HP	230/460	1PC28222CC316TA3		5395	2212	2258	97	91.7	494
20	1200	286HP	230/460	1PC28222CC416TA3		6607	2175	2226	120	91.7	551
6 Pole 460V											
25	1200	324HP	460	1PC28223AC312TA3		7420	2807	2906	169	93.0	773
30	1200	326HP	460	1PC28223AC412TA3		8472	2779	2879	187	93.0	809
40	1200	364HP	460	1PC28223CC312TA3		10990	3267	3388	187	94.1	802
50	1200	365HP	460	1PC28223CC412TA3		12931	3229	3348	208	94.1	835
60	1200	404HP	460	1PC28224AC312TA3		14005	3125	3283	274	94.5	1000
75	1200	405HP	460	1PC28224AC412TA3		16473	3064	3227	310	94.5	1068
100	1200	444HP	460	1PC28224HC112TA3		19556	3479	3743	347	95.0	1372
125	1200	445HP	460	1PC28224HC212TA3		24016	3310	3633	448	95.0	1557
150	1200	447HP	460	1PC28224HC312TA3		28696	3160	3539	522	95.8	1786
200	1200	449HP	460	1PC28224HC512TA3		31591	2880	3365	665	95.8	2216
250	1200	449HP	460	1PC28224HC612TA3		36131	2853	3284	671	95.8	2203

Add “-Z” at the end of the base part number, and short code “+K21”

NEMA Premium is a certification mark of the National Electrical Manufacturer's Association

LP100 | Eff: NEMA Premium | Vertical P-Base | Ball Bearings | 575V

Power HP	Speed RPM	NEMA Frame	Voltage	Base Part Number	Stock	List Price	Rated Thrust (Lbs)			Eff %	Weight (lbs)
							Down Thrust	Up Thrust	Radial Thrust		
2 Pole 575V											
3	3600	182HP	575	1PC28221DA113TA3		1482	901	908	24	86.5	118
5	3600	184HP	575	1PC28221DA213TA3		2077	889	896	34	88.5	130
7 ½	3600	213HP	575	1PC28222AA313TA3		2504	1681	1699	40	89.5	188
10	3600	215HP	575	1PC28222AA413TA3		2805	1668	1688	52	90.2	202
15	3600	254HP	575	1PC28222BA313TA3		3234	1631	1664	76	91.0	309
20	3600	256HP	575	1PC28222BA413TA3		3536	1609	1643	94	91.0	337
25	3600	284HP	575	1PC28222CA313TA3		4425	1525	1567	66	91.7	454
30	3600	286HP	575	1PC28222CA413TA3		4790	1508	1552	78	91.7	486
40	3600	324HP	575	1PC28223AA313TA3		6576	1952	2025	106	93.6	674
50	3600	326HP	575	1PC28223AA413TA3		8249	1938	2007	114	93.6	689
60	3600	364HP	575	1PC28223CA313TA3		10498	2226	2345	153	93.6	817
75	3600	365HP	575	1PC28223CA413TA3		12977	2192	2314	175	94.1	857
100	3600	405HP	575	1PC28224AA413TA3		14695	2110	2255	230	94.1	1023
4 Pole 575V											
3	1800	182HP	575	1PC28221DB113TA3		1308	1126	1134	39	89.5	129
5	1800	184HP	575	1PC28221DB213TA3		1821	1116	1122	45	89.5	135
7 ½	1800	213HP	575	1PC28222AB313TA3		2495	2102	2123	66	91.7	211
10	1800	215HP	575	1PC28222AB413TA3		2807	2091	2111	75	91.7	220
15	1800	254HP	575	1PC28222BB313TA3		3354	2052	2082	97	92.4	315
20	1800	256HP	575	1PC28222BB413TA3		3823	2021	2052	122	93.0	342
25	1800	284HP	575	1PC28222CB313TA3		4957	1890	1940	109	93.6	535
30	1800	286HP	575	1PC28222CB413TA3		5576	1876	1923	117	93.6	544
40	1800	324HP	575	1PC28223AB313TA3		6642	2427	2514	153	94.1	737
50	1800	326HP	575	1PC28223AB413TA3		7876	2366	2468	196	94.5	846
60	1800	364HP	575	1PC28223CB313TA3		10442	2767	2908	215	95.0	865
75	1800	365HP	575	1PC28223CB413TA3		13020	2703	2856	255	95.4	928
100	1800	405HP	575	1PC28224AB413TA3		15265	2616	2786	304	95.4	1073
125	1800	444HP	575	1PC28224HB113TA3		18932	2985	3243	342	95.4	1419
150	1800	445HP	575	1PC28224HB213TA3		21839	2874	3166	411	95.8	1559
200	1800	447HP	575	1PC28224HB313TA3		27746	2678	3035	516	96.2	1854
250	1800	449HP	575	1PC28224HB513TA3		30397	2466	2903	631	96.2	2246

Extra high thrust is available with option K21, refer to Technical Notes Section Bearing and Lubrication Table 6-2 for thrust values
 NEMA Premium is a certification mark of the National Electrical Manufacturer's Association.

LP100 | Eff: NEMA Premium | Vertical P-Base | Ball Bearings | 575V

Power HP	Speed RPM	NEMA Frame	Voltage	Base Part Number	Stock	List Price	Rated Thrust (Lbs)			Eff %	Weight (lbs)
							Down Thrust	Up Thrust	Radial Thrust		
6 Pole 575V											
3	1200	213HP	575	1PC28222AC313TA3		2029	2442	2413	51	89.5	192
5	1200	215HP	575	1PC28222AC413TA3		2857	2426	2413	62	89.5	204
7 ½	1200	254HP	575	1PC28222BC313TA3		3406	2389	2413	86	91.0	294
10	1200	256HP	575	1PC28222BC413TA3		3848	2369	2399	100	91.0	310
15	1200	284HP	575	1PC28222CC313TA3		5395	2212	2258	97	91.7	494
20	1200	286HP	575	1PC28222CC413TA3		6607	2175	2226	120	91.7	551
25	1200	324HP	575	1PC28223AC313TA3		7420	2807	2906	169	93.0	773
30	1200	326HP	575	1PC28223AC413TA3		8472	2779	2879	187	93.0	809
40	1200	364HP	575	1PC28223CC313TA3		10990	3267	3388	187	94.1	802
50	1200	365HP	575	1PC28223CC413TA3		12931	3229	3348	208	94.1	835
60	1200	404HP	575	1PC28224AC313TA3		14005	3125	3283	274	94.5	1000
75	1200	405HP	575	1PC28224AC413TA3		16473	3064	3227	310	94.5	1068
100	1200	444HP	575	1PC28224HC113TA3		19556	3479	3743	347	95.0	1372
125	1200	445HP	575	1PC28224HC213TA3		24016	3310	3633	448	95.0	1557
150	1200	447HP	575	1PC28224HC313TA3		28696	3160	3539	522	95.8	1786
200	1200	449HP	575	1PC28224HC513TA3		31591	2880	3365	665	95.8	2216
250	1200	449HP	575	1PC28224HC613TA3		36131	2853	3284	671	95.8	2203

Add “-Z” at the end of the base part number, and short code “+K21”

NEMA Premium is a certification mark of the National Electrical Manufacturer's Association.

3.2.4.3. Two Speed Motors – SD10MS



SD10 MS | Eff: NEMA Premium | 1 Winding Variable Torque | 4/8 Pole

Power HP	Speed RPM	NEMA Frame	Voltage	Base Part Number	Stock	List Price	Eff %	Weight (lbs)
460V Ball Bearing Long Shaft								
1/0.25	1800/900	143T	460	1LE23011AM240AA3		772	81.0/64.5	78
1.5/0.37	1800/900	145T	460	1LE23011AM340AA3		856	81.3/65.5	82
2/0.5	1800/900	182T	460	1LE23011CM140AA3		948	86.5/74.0	108
3/0.75	1800/900	184T	460	1LE23011CM340AA3		1052	87.5/78.5	114
5/1.2	1800/900	213T	460	1LE23012AM140AA3		1229	86.5/75.5	125
7.5/1.9	1800/900	215T	460	1LE23012AM240AA3	+	1617	87.5/78.5	195
10/2.5	1800/900	254T	460	1LE23012BM140AA3	+	2006	90.4/85.8	200
15/3.7	1800/900	256T	460	1LE23012BM240AA3	+	2642	90.2/86.5	256
20/5	1800/900	284T	460	1LE23012CM140AA3	+	3293	88.5/84.0	370
25/6.2	1800/900	286T	460	1LE23012CM240AA3	+	3905	89.5/85.5	430
30/7.5	1800/900	324T	460	1LE23013AM140AA3	+	4552	91.7/88.5	565
40/10	1800/900	326T	460	1LE23013AM240AA3	+	6047	92.4/88.5	600
50/12	1800/900	364T	460	1LE23013CM140AA3		7427	93.0/89.5	831
60/15	1800/900	365T	460	1LE23013CM240AA3		10655	93.0/88.5	875
75/19	1800/900	405T	460	1LE23014AM240AA3		13506	93.0/88.5	1050
100/25	1800/900	B444T	460	1LE23014EM140AA3		15263	93.6/91.0	1625
125/31	1800/900	B445T	460	1LE23014EM240AA3		19439	93.0/91.7	1900
150/37	1800/900	B447T	460	1LE23014EM340AA3		23463	93.6/90.2	2280
200/50	1800/900	B449T	460	1LE23014EM540AA3		28213	94.5/93.0	2600
250/62.5	1800/900	B449T	460	1LE23014EM640AA3		38956	93.6/91.0	2600
460V Ball Bearing Short Shaft								
100/25	1800/900	444TS	460	1LE23014DM140AA3		15263	93.6/91.0	1625
125/31	1800/900	445TS	460	1LE23014DM240AA3		19439	93.0/91.7	1900
150/37	1800/900	447TS	460	1LE23014DM340AA3		23463	93.6/90.2	2280
200/50	1800/900	449TS	460	1LE23014DM540AA3		28213	94.5/93.0	2600
250/62.5	1800/900	449TS	460	1LE23014DM640AA3		38956	93.6/91.0	2600

NEMA Premium is a certification mark of the National Electrical Manufacturer's Association

SD10 MS | Eff: NEMA Premium | 1 Winding Variable Torque | 4/8 Pole

Power HP	Speed RPM	NEMA Frame	Voltage	Base Part Number	Stock	List Price	Eff %	Weight (lbs)
460V Roller Bearing Long Shaft								
100/25	1800/900	444T	460	1LE23014CM140AA3		15871	93.6/91.0	1625
125/31	1800/900	445T	460	1LE23014CM240AA3		20047	93.0/91.7	1900
150/37	1800/900	447T	460	1LE23014CM340AA3		24071	93.6/90.2	2280
200/50	1800/900	449T	460	1LE23014CM540AA3		28821	94.5/93.0	2600
250/62.5	1800/900	449T	460	1LE23014CM640AA3		39564	93.6/91.0	2600

SD10 MS | Eff: NEMA Premium | 1 Winding Variable Torque | 4/8 Pole | 575V

Power HP	Speed RPM	NEMA Frame	Voltage	Base Part Number	Stock	List Price	Eff %	Weight (lbs)
575V Ball Bearing Long Shaft								
1/0.25	1800/900	143T	575	1LE23011AM244AA3		772	81.0/64.5	78
1.5/0.37	1800/900	145T	575	1LE23011AM344AA3		856	81.3/65.5	82
2/0.5	1800/900	182T	575	1LE23011CM144AA3		948	86.5/74.0	108
3/0.75	1800/900	184T	575	1LE23011CM344AA3		1052	87.5/78.5	114
5/1.2	1800/900	213T	575	1LE23012AM144AA3		1229	86.5/75.5	125
7.5/1.9	1800/900	215T	575	1LE23012AM244AA3		1617	87.5/78.5	195
10/2.5	1800/900	254T	575	1LE23012BM144AA3		2006	90.4/85.8	200
15/3.7	1800/900	256T	575	1LE23012BM244AA3		2642	90.2/86.5	256
20/5	1800/900	284T	575	1LE23012CM144AA3		3293	88.5/84.0	370
20/5	1800/900	284T	575	1LE23012CM144AA3		3293	88.5/84.0	370
25/6.2	1800/900	286T	575	1LE23012CM244AA3		3905	89.5/85.5	430
30/7.5	1800/900	324T	575	1LE23013AM144AA3		4552	91.7/88.5	565
40/10	1800/900	326T	575	1LE23013AM244AA3		6047	92.4/88.5	600
50/12	1800/900	364T	575	1LE23013CM144AA3		7427	93.0/89.5	831
60/15	1800/900	365T	575	1LE23013CM244AA3		10655	93.0/88.5	875
75/19	1800/900	405T	575	1LE23014AM244AA3		13506	93.0/88.5	1050
100/25	1800/900	B444T	575	1LE23014EM144AA3		15263	93.6/91.0	1625
125/31	1800/900	B445T	575	1LE23014EM244AA3		19439	93.0/91.7	1900
150/37	1800/900	B447T	575	1LE23014EM344AA3		23463	93.6/90.2	2280
200/50	1800/900	B449T	575	1LE23014EM544AA3		28213	94.5/93.0	2600
250/62.5	1800/900	B449T	575	1LE23014EM644AA3		38956	93.6/91.0	2600
575V Ball Bearing Short Shaft								
100/25	1800/900	444TS	575	1LE23014DM144AA3		15263	93.6/91.0	1625
125/31	1800/900	445TS	575	1LE23014DM244AA3		19439	93.0/91.7	1900
150/37	1800/900	447TS	575	1LE23014DM344AA3		23463	93.6/90.2	2280
200/50	1800/900	449TS	575	1LE23014DM544AA3		28213	94.5/93.0	2600
250/62.5	1800/900	449TS	575	1LE23014DM644AA3		38956	93.6/91.0	2600
575V Roller Bearing Long Shaft								
100/25	1800/900	444T	575	1LE23014CM144AA3		15871	93.6/91.0	1625
125/31	1800/900	445T	575	1LE23014CM244AA3		20047	93.0/91.7	1900
150/37	1800/900	447T	575	1LE23014CM344AA3		24071	93.6/90.2	2280
200/50	1800/900	449T	575	1LE23014CM544AA3		28821	94.5/93.0	2600
250/62.5	1800/900	449T	575	1LE23014CM644AA3		39564	93.6/91.0	2600

NEMA Premium is a certification mark of the National Electrical Manufacturer's Association.
 QuikMOD Delivery is for stocked motors only

3.3.

3.4. Option Selection and Pricing – Introduction



ABB offers a wide selection of options to increase the suitability of our motors to the specific customer needs.

Modified Stock Options:

Modified – 3-7 days

Special Testing – 15-25 days

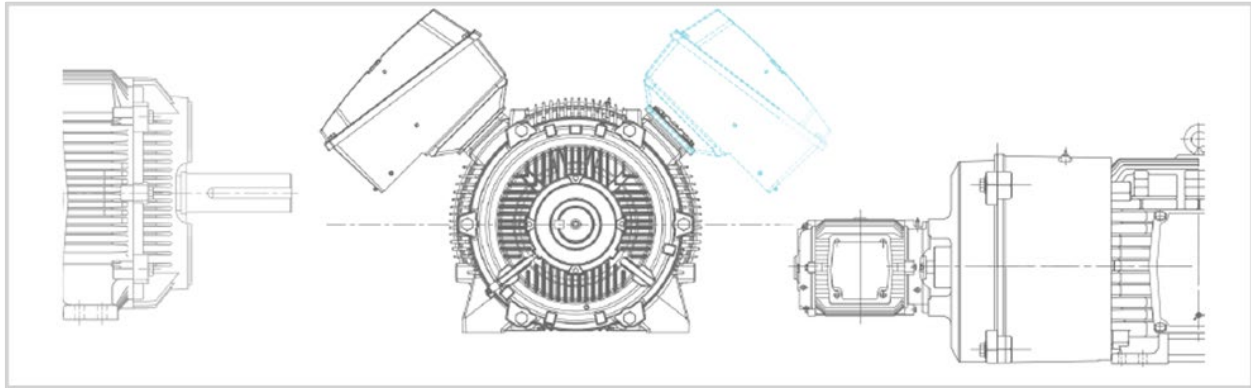
Note: Modification times are dependent on availability of materials.

Custom Build Options:

Case A-1: Base Custom Delivery

Case A-2: One additional week

Case B: Three additional weeks

Definitions:

MLFB Digit – Modifications or Custom features that are built into the motor part number (MLFB).

Short Codes – Modifications or Custom features that are added after the part number.

Ordering Instructions:

1. Select a stock motor from the Motor **Selection and Pricing Section** (Note Part Number)
2. **Verify applicability of desired Option(s) at the end of the section** (Per motor type and frame)
3. Select applicable Option(s)
4. Construct new Part Number and List Price. (See example below)

- a) If the MLFB Position is 12, 13, 14, 15 or 16, replace the number(s) or letter(s) at the same position(s) in the stock motor **Part Number** with the **MLFB Code**
- b) If the option is a Short Code, then add a '-Z' to the end of the motor **Part Number** and add the **short code**. Then add a '+' sign followed by the **additional short Code(s)**.

Custom Options combined with Modification options Motor Pricing Example:

Example: 15HP, 1800RPM, 208-230/460V, 254T, SD100, Copper Rotor, D-flange with feet, PTC thermistors(3 embedded temperature sensors for tripping) with conduit to main box and Class H insulation.

Base List Price	\$2,131	Part Number 1LE23112BB114AA3
List Price Adders		
D-Flange with Feet	\$774	Order Code F , Order Code Position 14
PTC Thermistors	\$634	Order Code B , Order Code Position 15
Condulet to Main Box	\$251	Order Code J02 , Order Code Position Z
Class H Insulation	\$157	Order Code C00 , Order Code Position Z
Total List Price	\$3,947	New Part Number – 1LE23112BB114FB3-Z J02+C00
Delivery		Please contact ABB for delivery

3.4.1. Option Selection and Pricing

Codes	Description	Custom Case	Modified	140	180	210	250	280	320	360	400	440	S449	1LE2	1MB2	1PC2	Notes
Voltage and Connection																	
MLFB DIGITS 12 & 13	11	230V	A-1	Mod ¹	123	123	138	159	161	161	191	191	230	-	+	+	1-75HP ONLY
	12	460V	A-1	Mod ¹	123	123	138	159	161	161	191	191	230	0	+	+	
	13	575V	A-1	-	0	0	0	0	0	0	0	0	0	0	+	+	
	14	230/460 (suitable for 208V)	A-1	-	0	0	0	0	-	-	-	-	-	-	+	+	NO IEEE
	16	230/460	A-1	Mod ¹	0	0	0	0	0	0	0	0	0	-	+	+	1-75HP ONLY, NO IEEE841
	22	PWS 460V 60Hz	A-1	-	-	-	-	-	165	200	294	461	767	767	+	+	
	23	PWS 575V 60HZ	A-1	-	-	-	-	-	165	200	294	461	767	767	+	+	
	32	Y/D 460V 60Hz	A-1	-	-	-	-	-	165	200	294	461	767	767	+	+	
	33	Y/D 575V 60HZ	A-1	-	-	-	-	-	165	200	294	461	767	767	+	+	
	90	200-600V (M1Y 200-460, M2Y 461-600)	A-1	-	120	120	120	166	200	482	546	714	1187	1486	+	+	
Mounting																	
MLFB DIGIT 14	A	Foot Mount	A-1	STK	0	0	0	0	0	0	0	0	0	0	+	+	-
	E	C - Face with Feet	A-1	Mod	106	154	164	229	870	941	1016	1261	1493	1720	+	+	NO 2 POLE 440 Frame IEEE, Roller Bearing
	F	D - Flange with Feet	A-1	Mod	284	361	396	774	1086	1269	1481	1976	2387	2390	+	+	NO 2 POLE 440 Frame IEEE, XP 140-250, Roller Bearing
	G	C - Face without Feet	A-1	Mod ²	90	132	132	180	939	1029	1308	1684	2303	-	+	+	NO 2 POLE 440 Frame IEEE, Roller Bearing
	H	D - Flange without Feet	A-1	Mod ²	302	396	428	809	1224	1452	2005	2779	3896	-	+	+	NO 2 POLE 440 Frame IEEE, XP 140-250, Roller Bearing
	L	C - Face without Feet with Drip Cover and Lifting Hooks	A-1	Mod ²	214	237	239	318	1106	1324	1907	2522	3853	-	+	+	NO 2 POLE 440 Frame IEEE, Roller Bearing
	M	D - Flange without Feet with Drip Cover and Lifting Hooks	A-1	Mod ²	455	549	581	976	1391	1747	2604	3617	5446	-	+	+	NO 2 POLE 440 Frame IEEE, XP 140-250, Roller Bearing

+ Available • Standard - Not Available C Custom - See Custom Options

- Modified only when stocked with "14" or "16"
- Modified only when stocked as round body

[Delivery Cases/Modified](#)

Codes	Description	Case	Modified	140	180	210	250	280	320	360	400	440	S449	1LE2	1MB2	1PC2	Notes	
Mounting (continued)																		
N	C - Face w Feet with Drip Cover	A-1	Mod	359	402	436	792	1037	1236	1615	2099	3043	3270	+	+	-	NO 2 POLE 440 Frame IEEE, Roller Bearing	
P	D - Flange w Feet with Drip Cover	A-1	Mod	437	514	549	941	1253	1564	2080	2814	3937	3940	+	+	-	NO 2 POLE 440 Frame IEEE, XP 140-250, Roller Bearing	
T	P-Base without Feet with Drip Cover and Lifting Hooks	A-1	STK	-	-	-	+		
V	CH - Flange w Feet with Drip Cover	A-1	-	-	342	-	-	-	-	-	-	-	-	-	+	-		
W	CH - Flange with Feet	A-1	-	-	131	-	-	-	-	-	-	-	-	-	+	-		
X	CH - Flange without Feet	A-1	-	-	112	-	-	-	-	-	-	-	-	-	+	-		
Y	CH - Flange without Feet with Drip Cover and Lifting Hooks	A-1	-	-	202	-	-	-	-	-	-	-	-	-	+	-		
Winding Protection																		
A	No Protection	A-1	STK	0	0	0	0	0	0	0	0	0	0	0	+	+	+	
B	PTC 3 Embedded, 1 Per Phase	A-1	-	634	634	634	634	634	634	634	634	634	634	634	+	+	+	NO GP100A
C	PTC 6 Embedded, 2 Per Phase	A-1	-	1268	1268	1268	1268	1268	1268	1268	1268	1268	1268	1268	+	+	+	NO GP100A
MLFB DIGIT 15	G	Thermostats Normally Closed, Temp Code T3C, 1 Per Phase	A-1	Mod	229	229	229	229	229	306	306	459	566	661	+	+	+	NO GP100A, XP100 1D1
	J	Thermocouples Coil Head	A-1	-	-	-	-	-	-	1814	1814	1814	1887	+	+	+	NO GP100A	
	K	Stator RTD's 100-Ohm Platinum w Aux Box-terminal Strip 2/Phase	A-1	-	-	-	-	-	-	3053	3053	3053	3175	+	+	+	NO GP100A, XP100 ID1	

+ Available • Standard - Not Available C Custom - See Custom Options

Note: See Weekly Stock List for updated lead times on delivery cases

[Delivery Cases/Modified](#)

Codes	Description	Case	Modified	140	180	210	250	280	320	360	400	440	5449	1LE2	1MB2	1PC2	Notes	
Winding Protection (continued)																		
MLFB DIGIT 15	L	Winding Protection - G + K	A-1	-	-	-	-	-	-	279	279	279	288	+	+	+	NO GP100A, XP100 ID1	
	P	PT1000, 2 Embedded Temperature Sensors	A-1	-	126	126	126	126	126	126	126	126	126	+	+	+	NO GP100A	
Short Codes	A46	Space Heaters 115V Single Phase, Max Temp 160°C	A-1	Mod	300	300	300	300	500	500	500	610	610	610	+	+	+	
	A47	Space Heaters 230V Single Phase, Max Temp 160°C	A-1	Mod	300	300	300	300	500	500	500	610	610	610	+	+	+	
	A48	Space Heaters 115/230V Single Phase, Max Temp 160°C	A-1	Mod	-	-	300	300	550	550	550	610	610	610	+	+	+	
	A90	Control Module	B	-	725	725	725	725	725	725	725	725	725	725	+	+	+	NO GP100A
	C00	Insulation Class H	A-1	-	122	122	122	157	261	343	438	634	904	2387	+	+	+	NO GP100A
	C01	Insulation Vacuum Pressure Impregnation (VPI)	A-2	-	2600	2600	2600	2600	3400	3400	3400	4250	3728	5463	+	+	+	NO GP100A
	C03	Spike Resistant Wire	A-2	-	150	150	150	150	150	150	220	260	410	820	+	+	+	
	C04	Insulation Moisture/Pow erhouse (Extra Dip & Bake)	A-2	-	160	160	160	208	300	380	405	650	800	800	+	+	+	NO GP100A
C07	Insulation Fungus Protection - No UL	A-1	Mod	200	200	200	200	200	200	225	250	280	280	+	-	+	NO GP100A	
C08	Insulation Tropical- ization (Extra Dip & Bake + Fungus Spray)	A-2	-	214	214	214	277	400	480	530	800	980	980	+	-	+	NO GP100A	

+ Available • Standard - Not Available C Custom - See Custom Options Delivery Cases/Modified

Codes	Description	Case	Modified	140	180	210	250	280	320	360	400	440	S449	1LE2	1MB2	1PC2	Notes		
Terminal Boxes and Leads																			
MLFB DIGIT 16	0	F-3 Top Mounted Box	A-1	Mod	125	125	125	125	-	-	-	-	-	-	+	-	-	ONLY GP100A	
	1	C-2 Ceiling	A-1	Mod	134	134	134	134	134	134	134	134	134	134	+	+	-		
	2	F-2	A-1	Mod ¹	284	284	284	284	284	284	284	284	284	284	+	+	-		
	3	F-1	A-1	Mod	+	+	+	
	4	W-6 Shaft Down	A-1	Mod	202	202	202	202	202	202	202	202	202	202	+	+	-		
	5	W-7 (F-2) Shaft Down	A-1	Mod ¹	288	288	288	288	288	288	288	288	288	288	288	+	+	-	
	6	W-5 (F-2) Shaft Up	A-1	Mod ¹	284	284	284	284	284	284	284	284	284	284	284	+	+	-	
	7	W-8 Shaft Up	A-1	Mod	131	131	131	131	131	131	131	131	131	131	131	+	+	-	
	8	C-1 (F-2) Ceiling	A-1	Mod ¹	284	284	284	284	284	284	284	284	284	284	284	+	+	-	
	9-R1A	W-1 (F-2) Wall	A-1	Mod ¹	284	284	284	284	284	284	284	284	284	284	284	+	+	-	
9-R2A	W-2 Wall	A-1	Mod	130	130	130	130	130	130	130	130	130	130	130	+	+	-		
9-R3A	W-3 Wall	A-1	Mod	130	130	130	130	130	130	130	130	130	130	130	+	+	-		
9-R4A	W-4 (F-2) Wall	A-1	Mod ¹	284	284	284	284	284	284	284	284	284	284	284	+	+	-		
Short Codes	J00	Separate Condulet on Main Box Side for PTC	A-1	-	-	-	-	235	235	235	235	235	235	235	+	-	+	NO GP100A	
	J02	Condulet to Main Box for PTC	A-1	-	251	251	251	251	251	251	251	251	251	251	+	-	+	NO GP	
	J03	Aux Box to Main Box for PTC	A-1	-	-	-	-	415	415	415	415	415	415	415	+	-	+	NO GP	
	J04	Condulet Opp Side to Main for PTC	A-1	-	-	-	-	235	235	235	235	235	235	235	+	-	+	NO GP100A	
	J05	Aux Box Opp Side to Main for PTC	A-1	-	-	-	-	443	443	443	443	443	443	443	+	-	+	NO GP100A	
	J06	Explosion Proof Condulet Opp to Main for PTC	A-1	-	560	560	560	560	560	560	560	560	560	560	-	-	+	-	
	J07	Explosion Proof Condulet to Main Box for PTC	A-1	-	560	560	560	560	560	560	560	560	560	560	-	-	+	-	

+ Available • Standard - Not Available C Custom - See Custom Options Delivery Cases/Modified

Codes	Description	Case	Modified	140	180	210	250	280	320	360	400	440	S449	1LE2	1MB2	1PC2	Notes	
Terminal Boxes and Leads (continued)																		
Short Codes	J10	Separate Condulet on Main Box Side for Thermostats	A-1	-	-	-	-	235	235	235	235	235	235	+	-	+	NO GP100A	
	J12	Condulet to Main Box for Thermostats	A-1	Mod	251	251	251	251	251	251	251	251	251	+	-	+	NO GP	
	J13	Aux Box to Main Box for Thermostats	A-1	Mod	-	-	-	-	415	415	415	415	415	+	-	+	NO GP	
	J14	Condulet Opp Side to Main for Thermostats	A-1	-	-	-	-	-	235	235	235	235	235	+	-	+	NO GP100A	
	J15	Aux Box Opp Side to Main for Thermostats	A-1	-	-	-	-	-	443	443	443	443	443	+	-	+	NO GP100A	
	J16	Explosion Proof Condulet Opp to Main for Thermostats	A-1	-	560	560	560	560	560	560	560	560	560	NA	-	+	-	
	J17	Explosion Proof Condulet to Main Box for Thermostats	A-1	-	560	560	560	560	560	560	560	560	560	-	-	+	-	
	J20	Separate Condulet on Main Box Side for PT1000	A-1	-	-	-	-	-	235	235	235	235	235	235	+	-	+	NO GP100A
	J22	Condulet to Main Box for PT1000	A-1	-	251	251	251	251	251	251	251	251	251	251	+	-	+	NO GP
	J23	Aux Box to Main Box for PT1000	A-1	-	-	-	-	-	415	415	415	415	415	415	+	-	+	NO GP
	J24	Condulet Opp Side to Main for PT1000	A-1	-	-	-	-	-	235	235	235	235	235	235	+	-	+	NO GP100A
	J25	Aux box Opp Side to Main for PT1000	A-1	-	-	-	-	-	443	443	443	443	443	443	+	-	+	NO GP100A
	J26	Explosion Proof Condulet Opp to Main for PT1000	A-1	-	560	560	560	560	560	560	560	560	560	-	-	+	-	
	J27	Explosion Proof Condulet to Main Box for PT1000	A-1	-	560	560	560	560	560	560	560	560	560	-	-	+	-	

+ Available • Standard - Not Available C Custom - See Custom Options

[Delivery Cases/Modified](#)

Codes	Description	Case	Modified	140	180	210	250	280	320	360	400	440	S449	1LE2	1MB2	1PC2	Notes	
Terminal Boxes and Leads (continued)																		
J50	Separate Condulet on Main Box Side for Space Heaters	A-1	-	235	235	235	235	235	235	235	235	235	235	+	-	+	NO GP100A	
J52	Condulet to Main Box for Space Heaters	A-1	Mod	251	251	251	251	251	251	251	251	251	251	+	-	+	NO GP	
J53	Aux Box to Main Box for Space Heaters	A-1	Mod	-	-	-	-	415	415	415	415	415	415	+	-	+	NO GP	
J54	Condulet Opp Side to Main Box for Space Heaters	A-1	-	-	-	-	-	235	235	235	235	235	235	+	-	+	NO GP100A	
Short Codes	J55	Aux Box Opp Side to Main Box for Space Heaters	A-1	-	-	-	-	443	443	443	443	443	443	+	-	+	NO GP100A	
	J56	Explosion Proof Condulet Opp of Main for Space Heaters	A-1	-	560	560	560	560	560	560	560	560	560	-	-	+	-	
	J57	Explosion Proof Condulet to Main Box for Space Heaters	A-1	-	560	560	560	560	560	560	560	560	560	-	-	+	-	
	J84	Conduit Box Orientation 90° CCW (Entry from DE)	A-1	Mod	134	134	134	134	134	134	134	134	134	134	+	+	+	NO GP100A
	J85	Conduit Box Orientation 180° CCW (Entry from Top)	A-1	Mod	134	134	134	134	134	134	134	134	134	134	+	+	+	NO GP100A

+ Available • Standard - Not Available C Custom - See Custom Options

Delivery Cases/Modified

Codes	Description	Case	Modified	140	180	210	250	280	320	360	400	440	S449	1LE2	1MB2	1PC2	Notes
Terminal Boxes and Leads (continued)																	
J86	Conduit Box Orientation 270° CCW (Entry from ODE)	A-1	Mod	134	134	134	134	134	134	134	134	134	134	+	+	+	NO GP100A
K80	BURNDY HYDENT YA Type Terminals	A-2	Mod	171	171	171	171	171	171	171	171	171	171	+	+	+	
K83	Terminal Block - 3 Lead Only	A-1	Mod	228	228	228	342	342	518	518	-	-	-	+	-	+	NO GP100A
K89	Sealed Leads	A-1	Mod	150	150	150	150	150	150	150	200	200	200	+	•	+	NO GP100A
L01	Cast Iron Main Terminal Box in Lieu of Aluminum	A-2	Mod	148	154	161	167	180	199	218	251	-	-	+	•	•	ONLY GP100
T04	Steel terminal box - oversized - blank entry	A-2	-	-	-	-	-	-	-	-	-	2880	2880	+	•	•	
Y85	Special Cable Length	A-1	-	228	228	228	228	228	228	304	304	304	304	+	-	+	

Bearings and Lubrication																		
Short Codes	A51	Bearing RTD's- 100 Ohm Platinum - Both Ends & Terminal Heads/Block	A-2	-	-	-	-	-	-	-	3347	3347	3347	+	-	+	NO GP	
	K21	Extra High Thrust	B	--	--	700	700	700	700	970	1230	1410	1760	-	-	+		
	L54	Provisions for Oil Mist	A-1	--	350	350	360	360	380	380	650	1100	1350	-	+	-	-	NO GP
	L55	Oil Mist Ready	A-1	--	350	350	360	360	380	380	650	1100	1350	-	+	-	-	NO GP
	L57	MOBIL 28 - High or Low - Special Grease	A-2	Mod	485	895	895	895	895	1230	1230	1640	1640	1640	+	+	+	NO GP100A
	L58	MOBILITH SHC 100 -Special Grease	A-2	Mod	336	336	336	336	336	634	634	634	634	634	+	+	+	NO GP100A

+ Available • Standard - Not Available C Custom - See Custom Options

Delivery Cases/Modified

Codes	Description	Case	Modified	140	180	210	250	280	320	360	400	440	S449	1LE2	1MB2	1PC2	Notes
Bearings and Lubrication (continued)																	
L60	ALEMITE and Grease Relief Fitting	A-1	Mod	186	186	186	186	186	186	186	186	186	186	+	-	+	GP100 280-S449 ONLY, STD on SD100 IEEE, SD661
L61	Insulated Bearing - INSOCOAT (Both Ends)	A-1	Mod	-	-	-	-	-	-	3700	4000	4000	4700	+	+	+	
L64	Insulated Bearing - INSOCOAT (NDE Only)	A-1	Mod	-	-	-	-	-	-	1850	2000	2000	2350	+	+	+	
L65	Roller Instead of Ball Bearings	A-2	Mod	-	-	-	-	1215	1215	1215	1215	-	-	+	+	-	NO GP
L66	Insulated Bearings on Both Ends	B	-	765	765	1050	1315	2496	2961	3523	7645	11767	11843	+	-	-	SD ONLY, NO Roller Bearing
L67	Insulated NDE Only	B	-	380	385	525	660	1252	1484	1761	3823	5884	8343	+	-	-	SD ONLY
L68	Sealed Ball Bearings (Both Ends)	A-1	Mod	229	229	229	458	458	458	572	916	916	1207	+	+	+	NO SD IEEE, SD661, NO 2 pole for 360-S449
L69	Hybrid (Ceramic Ball) Bearings - both Ends	B	Mod	1328	1328	2096	2332	3316	4818	6236	10850	11606	12750	+	+	-	NO GP, MS, LP100, Roller Bearing DE
L70	Hybrid (Ceramic Ball) Bearings - NDE	B	Mod	664	664	1048	1166	1658	2409	3118	5425	5803	6150	+	+	+	NO GP, MS, LP100
L71	Hybrid (Ceramic Ball) Bearings - DE	B	Mod	-	664	1048	1166	1658	2409	3118	5425	5803	6150	+	+	+	NO GP, MS, Roller Bearing DE

+ Available • Standard - Not Available C Custom - See Custom Options

[Delivery Cases/Modified](#)

Codes	Description	Case	Modified	140	180	210	250	280	320	360	400	440	S449	1LE2	1MB2	1PC2	Notes	
				Shafts and Seals														
Short Codes	K41	Keyless Shaft	A-1	-	250	250	250	250	250	250	250	250	250	+	+	+	NO GP	
	L29	Shaft Grounding Brush	A-2	Mod	-	-	-	-	3800	3800	3800	3800	3800	3800	+	-	-	NO GP, MS, Removes Div 2
	L76	Shaft Slinger & O Ring	A-1	Mod	88	88	88	121	121	164	164	213	213	213	+	+	+	NO GP100A, NO 2 Pole
	L79	INPRO/SEAL DE	A-1	Mod	511	511	533	622	644	678	778	955	1044	1044	+	+	+	NO GP100A; STD ON SD IEEE, SD661
	L80	INPRO/SEAL ODE	A-2	Mod	511	511	533	622	644	678	778	955	1044	1044	+	+	+	NO GP100A; STD ON SD IEEE, SD661
	L81	INPRO/SEAL Both Ends	A-2	Mod	1021	1021	1066	1244	1289	1356	1556	1911	2088	2088	+	+	+	NO GP100A; STD ON SD IEEE, SD661
	L84	Brass Seal	A-1	-	133	133	133	133	133	133	133	133	133	-	+	+	+	NO S449, NO GP, SD IEEE, SD661
	L89	INPRO/SEAL MGS shaft grounding - DE	A-1	Mod	760	830	990	1120	1240	1390	1510	1770	2490	2490	+	-	+	NO GP, MS, Removes Div 2
	M42	Shaft Ring Brush (Steel) - NDE (AEGIS)	A-2	-	321	342	375	456	489	551	743	930	2270	-	+	-	-	GP100 ONLY
	M52	NEMA Std Long Shaft - NDE	A-2	-	132	132	132	176	272	392	443	490	558	-	+	+	-	NO GP
	M53	NEMA Std Short Shaft - NDE	A-2	-	-	-	-	-	272	392	443	490	558	-	+	+	-	NO GP
	M57	(C4140) Carbon Steel Shaft	A-2	-	-	-	-	-	-	-	-	1225	1800	1800	+	-	+	
	Y50	Special Shaft on Drive End	B	-	CF	CF	CF	CF	CF	CF	CF	CF	CF	CF	+	+	+	
	Y51	Special Shaft on Non-Drive End	B	-	CF	CF	CF	CF	CF	CF	CF	CF	CF	CF	+	+	+	NO GP
	Frame																	
	Short Codes	K33	Drip Cover	A-1	Mod	153	153	153	167	167	295	599	838	1550	1550	+	+	•
		K34	Vertical Lifting Devices (No Drip Cover)	A-1	Mod	235	286	286	388	416	720	720	908	1001	1001	+	+	•
K38		Provisions for Dowel Holes	A-1	Mod	-	-	-	-	435	483	530	614	915	915	+	+	-	NO GP100A

+ Available • Standard - Not Available C Custom - See Custom Options
 Delivery Cases/Modified

Codes	Description	Case	Modified	140	180	210	250	280	320	360	400	440	S449	1LE2	1MB2	1PC2	Notes	
				Frame (continued)														
Short Codes	K70	Rotation Arrow Bidirectional (Not for Uni-Directional)	A-1	Mod	142	142	142	142	142	142	142	142	142	142	+	+	+	
	K71	Rotation Arrow Clockwise (From NDE)	A-1	Mod	142	142	142	142	142	142	142	142	142	142	+	+	+	
	K72	Rotation Arrow Counterclockwise (From NDE)	A-1	Mod	142	142	142	142	142	142	142	142	142	142	+	+	+	
	L20	Lifting Eyebolt	A-1	Mod	43	+	.	.	ONLY GP100
	L22	Stainless Steel Hardware (Includes T Drain SS)	A-1	Mod	203	203	203	203	203	251	308	380	468	641	+	-	+	NO GP100A
	L27	Ground Bolts - Qty 2	A-1	Mod	142	142	142	164	164	186	186	186	266	266	+	+	+	NO GP100A
	L45	SS T - Slot Breather Drain	A-1	Mod	161	161	161	234	234	234	307	307	307	307	+	-	+	NO GP100A
	L46	CROUSE HINDS UL Approved Breather Drain	A-1	Mod	-	-	-	-	353	353	353	353	353	353	+	+	+	NO GP
	L90	IP66 Ingress Protection	A-1	Mod	1021	1021	1066	1244	1289	1356	1556	1911	2088	-	-	+	-	XP Only
	L90	IP66 Ingress Protection	A-1		860	860	860	860	1465	1790	2005	2160	2800	3500	+	-	-	SD Only
L91	IP56 Ingress Protection	A-1		545	545	545	545	1265	1445	1640	1745	2430	3130	+	-	-	NO GP	
L92	IP65 Ingress Protection	A-1		860	860	860	860	1465	1790	2005	2160	2800	3500	+	.	-	NO GP	
M09	Aluminum Fan	A-2	-	145	163	166	197	209	228	238	273	315	-	+	-	-	ONLY SD100	
M10	Bronze Fan	A-1	-	546	546	706	752	941	1137	1190	1325	1830	-	+	-	+	NO GP100A	
M28	Stainless Steel Eyebolt	A-1	Mod	161	161	161	161	161	161	161	161	161	161	+	+	-	NO GP100A	
M39	Vertical Jacking Provisions	A-1	-	-	-	-	-	550	550	550	550	550	550	+	-	+		

+ Available • Standard - Not Available C Custom - See Custom Options

1. aux tag only (Includes Class I)

Delivery Cases/Modified

Codes	Description	Case	Modified	140	180	210	250	280	320	360	400	440	S449	1LE2	1MB2	1PC2	Notes	
Rating Plates and Tagging																		
C40	Re-rate 400V to 380V, 50HZ	A-1	Mod	164	164	164	164	164	164	164	164	164	164	164	+	+	+	
C41	Re-rate 400V to 415V, 50HZ	A-1	Mod	164	164	164	164	164	164	164	164	164	164	164	+	+	+	
M21	Additional Nameplate (without Logos)	A-1	-	164	164	164	164	164	164	164	164	164	164	164	+	+	+	
M24	Lubrication Plate	A-1	Mod	104	104	104	104	104	104	104	104	104	104	104	+	+	+	
Short Codes	M25	Class II, Division 2, Groups F & G, T3C Temp Code	A-2	Mod	600	600	600	600	-	-	+	+	+	No GP
	M32	Class II, Group E Hazardous Area	A-2	-	512	512	727	743	828	995	1164	1332	1737	-	-	+	-	
	Y80	Derate-Alt-Amb (Nameplate Change)	A-1	Mod	164	164	164	164	164	164	164	164	164	164	+	+	+	
	Y82	Auxiliary n/p Max. 40 Characters (Aux Tag)	A-1	Mod	164	164	164	164	164	164	164	164	164	164	+	+	+	
Ambient																		
Short Codes	B27	+40°C to -30°C Ambient Temp	A-2	-	190	200	265	310	385	440	510	690	895	895	+	-	+	NO GP
	B28	+40°C to -40°C Ambient Temp	B	-	325	455	510	555	610	680	800	975	1175	1175	+	-	+	NO GP
	B29	+40°C to -50°C Ambient Temp	B	-	340	465	525	570	655	720	865	1075	1280	1280	+	-	+	NO GP
Mechanical Design and Accessories																		
A66	Vibration Detectors, Model 366-D8 120VAC	A-2	-	-	-	-	-	4216	4216	4216	5170	5170	5170	+	-	-		
A67	Provision Only for Vibration Sensors	A-2	-	-	-	-	-	500	500	500	500	500	500	500	+	-	+	
G05	DYNAPAR Encoder HS35 1024 PPR	B	-	1900	1900	1900	1900	1900	1900	1900	1900	1900	1900	1900	+	-	+	NO GP, MS, Removes Div 2

+ Available • Standard - Not Available C Custom - See Custom Options

1. aux tag only (Includes Class I)

[Delivery Cases/Modified](#)

Codes	Description	Case	Modified	140	180	210	250	280	320	360	400	440	5449	1LE2	1MB2	1PC2	Notes
Mechanical Design and Accessories (continued)																	
G06	C-Face Mounted SLIM Tach Encoder	B	-	3350	3720	4135	4595	6055	6070	6080	6230	6380	6380	+	-	+	NO GP, MS
H04	C-Face Mounted Brake	B	-	3480	3870	4300	4775	6915	13900	19170	29245	32495	32495	+	-	-	NO GP, MS
K10	IEEE 841 Features	B	-	625	625	625	700	700	750	800	900	960	960	+	-	+	NO GP, MS, SD661, SD841
K20	API 610	B	-	-	250	250	460	460	460	580	920	920	-	-	-	+	
M05	Larger Fan	A-2	-	-	-	-	-	-	-	320	320	360	-	+	+	-	NO GP, SD661; ONLY 4 Pole
M08	Separately Driven Fan	A-2	-	-	-	-	1120	1065	1160	1290	1325	1470	CF	+	-	-	NP GP, MS
M18	Non-Reverse Ratchet	B	-	-	-	350	400	500	700	1075	1720	2260	-	-	-	+	
M69	Precision Balance	A-1	-	190	190	190	218	218	248	248	313	313	610	+	+	+	
M70	Extra Precision Balance	A-1	-	312	312	330	330	376	376	506	506	651	683	+	+	+	
Paint and Packaging																	
B07	Special Stackable Crate Packing	A-1	-	-	-	-	-	105	110	120	205	-	-	+	+	-	
B09	Export Packaging Sea Freight - ABB Standard	A-1	Mod	150	230	370	370	370	500	600	900	1010	1010	+	+	+	
B10	Export Packaging Special Export Box	A-2	-	CF	CF	CF	CF	CF	CF	CF	CF	CF	CF	+	+	+	
Short Codes	N01	2 Part Epoxy (Industrial-Coastal Low Salt)	B	-	430	550	585	675	830	925	945	1105	1320	1430	+	+	+
	N02	3 Part Epoxy (Industrial-Coastal Moderate Salt)	B	-	520	655	710	820	1005	1120	1145	1340	1600	1735	+	+	+
	N03	Primer Only	A-1	-	560	560	560	560	560	560	560	560	560	560	+	+	+
	N05	3 Part Epoxy (Coastal-Offshore High Salt)	B	-	625	830	880	1048	1255	1465	1675	1915	2160	2375	+	+	+

+ Available • Standard - Not Available C Custom - See Custom Options

Delivery Cases/Modified

Codes	Description	Case	Modified	140	180	210	250	280	320	360	400	440	S449	1LE2	1MB2	1PC2	Notes	
Paint and Packaging (continued)																		
N06	2 Part Epoxy C4 (Industrial-Coastal moderate salt)	B	-	525	620	675	780	955	1065	1090	1275	1520	1650	+	+	+		
N07	2 Part Epoxy C5I/C5M (Coastal-offshore high salt)	B	-	595	790	835	995	1190	1390	1590	1820	2050	2255	+	+	+		
Y60	Special color (Provide RAL#)	A-2	-	200	200	200	200	200	200	200	200	200	200	+	-	+		
Y61	Special color (Provide RAL#)	A-2	-	100	100	100	100	100	100	100	100	100	100	+	+	+	Must include N01, N02, N05, N06, or N07	
Documentation																		
D05	Documentation in Spanish	A-1	-	0	0	0	0	0	0	0	0	0	0	+	+	+		
F00	Certificate of Compliance	A-1	Mod	300	300	300	300	300	300	300	300	300	300	+	+	+		
F01	Certificate of Origin - Stamped by Chamber of Commerce	A-1	Mod	900	900	900	900	900	900	900	900	900	900	+	+	+		
F03	Standard Performance Curves	A-1	Mod	747	747	747	747	747	747	747	747	747	747	+	+	+		
Short Codes	F04	Acceleration Time Calculation	A-1	Mod	190	190	190	190	190	190	190	190	190	+	+	+		
	F05	Polarization Index	A-1	-	150	150	150	150	150	150	150	150	150	+	+	+		
	F07	Curve Package at 100% and 80% voltage (S-T, PERF)	A-1	Mod	1195	1195	1195	1195	1195	1195	1195	1195	1195	+	+	+		
	F08	Shaft Torsional Analysis (includes shaft drawing)	A-1	Mod	500	500	500	500	500	500	500	500	500	500	+	+	+	
	F09	Bearing L10 Calculation	A-1	Mod	550	550	550	550	550	550	550	550	550	550	+	+	+	
F40	Stall Time Curve (Thermal Limit Curve)	A-1	Mod	45	45	45	45	45	45	45	45	45	45	+	+	+		

+ Available • Standard - Not Available C Custom - See Custom Options

Delivery Cases/Modified

Codes	Description	Case	Modified	140	180	210	250	280	320	360	400	440	S449	1LE2	1MB2	1PC2	Notes
Documentation (continued)																	
F42	Standard Dimensional Sheet	A-1	Mod	45	45	45	45	45	45	45	45	45	45	+	+	+	
F43	Non-Standard Dimension Sheet	A-2	Mod	523	523	523	523	523	523	523	523	523	523	+	+	+	
F44	Conduit Box Dimension Sheet	A-1	Mod	45	45	45	45	45	45	45	45	45	45	+	+	+	
F45	Wiring Diagram	A-1	Mod	45	45	45	45	45	45	45	45	45	45	+	+	+	
F46	Instruction and Operation Manual in English	A-1	Mod	45	45	45	45	45	45	45	45	45	45	+	+	+	
F47	Renewal Parts	A-1	Mod	45	45	45	45	45	45	45	45	45	45	+	+	+	
F48	CAD Drawing (Dwg Format) Customer/ Application Specific	A-1	Mod	610	610	610	610	610	610	610	610	610	610	+	+	+	
F49	Performance Data Sheets	A-1	Mod	261	261	261	261	261	261	261	261	261	261	+	+	+	
F50	Customer Specific Data Sheets	A-2	Mod	523	523	523	523	523	523	523	523	523	523	+	+	+	
F60	Visual Inspection Proof (Max 8X Photos)	A-1	Mod	340	340	340	340	340	340	340	340	340	340	+	+	+	
F70	Inspection Test Plan	A-1	-	500	500	500	500	500	500	500	500	500	500	+	+	+	
F71	Paint Report (thickness and adherence)	A-1	-	150	150	150	150	150	150	150	150	150	150	+	+	+	
F81	Advanced Document Package	A-1	-	1500	1500	1500	1500	1500	1500	1500	1500	1500	1500	+	+	+	
F82	Project Document Package	A-2	-	3000	3000	3000	3000	3000	3000	3000	3000	3000	3000	+	+	+	

+ Available • Standard - Not Available C Custom - See Custom Options

Delivery Cases/Modified

Codes	Description	Case	Modified												Notes			
				140	180	210	250	280	320	360	400	440	5449	1LE2	1MB2	1PC2		
Tests																		
Short Codes	F10	Routine Test Report	A-1 Mod	300	300	300	300	300	300	300	300	300	300	300	+	+	+	NO SDIEEE
	F12	Routine Test Report (Witnessed)	A-2 Mod	1628	1628	1628	1628	1643	1972	2360	2569	2778	3672	+	+	+	NO SDIEE	
	F15	Complete Test	A-1 Mod	6749	6749	6749	6749	6812	7917	9680	11054	12010	13596	+	+	+		
	F17	Complete Test (Witnessed)	A-1 Mod	10123	10123	10123	10123	10217	11890	14519	16581	18015	20394	+	+	+		
	F20	Routine Test + Vibration	A-1 Mod	600	600	600	600	600	600	600	600	600	600	600	+	+	+	
	F22	Routine Test + Vibration (Witnessed)	A-1 Mod	3256	3256	3256	3256	3286	3286	3286	3286	3286	3286	3286	+	+	+	
	F27	Performance Load Test (Curve Report)	A-1 Mod	5062	5062	5062	5062	5109	5938	7260	8290	9007	10197	+	+	+		
	F30	Noise Test	A-1 --	4144	4144	4144	4144	4183	4183	5378	5378	5378	5463	+	+	+		
	F32	Noise Test (Witnessed)	A-1 --	6512	6512	6512	6512	6573	7768	7768	7768	7768	7891	+	+	+		
	F36	Routine Test Report of Electrical Duplicate Design	A-1 Mod	300	300	300	300	300	300	300	300	300	300	300	+	+	+	
F37	Type Test Report of Electrical Duplicate Design	A-1 Mod	455	455	455	455	455	455	455	455	455	455	455	+	+	+		

+ Available • Standard – Not Available C Custom - See Custom Options
 Delivery Cases/Modified

4. Technical Tables

VFD capabilities, bearing details,
typical performance data

- 4.1. VFD Capabilities188**
 - 4.1.1. Next Generation188
 - 4.1.1.1. SD200, SD200 841, DP200 HPS188
 - 4.1.2. Low Voltage NEMA.....189
 - 4.1.2.1. GP100A, GP100.....189
 - 4.1.2.2. SD100, SD100 IEEE, SD661190
 - 4.1.2.3. XP100, XP100 ID1191
- 4.2. Bearing Tables.....192**
 - 4.2.1. Next Generation – Bearing Sizes.....192
 - 4.2.1.1. SD200, SD200 841, DP200 HPS192
 - 4.2.2. Low Voltage NEMA – Bearing Sizes192
 - 4.2.2.1. GP100A, GP100, SD100, SD100 IEEE, SD661.....192
 - 4.2.2.2. 4.2.2.2. XP100, XP100 ID1, SD10 MS194
 - 4.2.2.3. HP100, LP100.....195
 - 4.2.3. Low Voltage NEMA – Rated Thrust.....196
 - 4.2.3.1. LP100.....196
- 4.3. Typical Performance Data198**
 - 4.3.1. Next Generation198
 - 4.3.1.1. SD200, SD200 841, DP200 HPS198
 - 4.3.1.2. SD200, DP200 HPS – FS500200
 - 4.3.2. Low Voltage NEMA.....201
 - 4.3.2.1. GP100A, GP100.....201
 - 4.3.2.2. SD100, SD100 IEEE, SD661205
 - 4.3.2.3. XP100, XP100 ID1210
 - 4.3.2.4. LP100, HP100.....214
 - 4.3.2.5. SD10 MS.....220
- 4.4. Additional Technical Tables.....221**
 - 4.4.1. Paint System Chart221
 - 4.4.2. Balance Table222

4.1. VFD Capabilities

4.1.1. Next Generation Low Voltage NEMA Motors

4.1.1.1. SD200, SD200 841, DP200 HPS

Severe Duty Low Voltage NEMA Motors (SD200, SD200 841, DP200)

Frame	Poles	Standard		M05 Option	M08	Temp Codes	
		Constant Torque	Variable Torque	Constant Torque	Constant Torque	Standard	Standard
						Class I, Division 2	Class II, Division 2
		Temp Code			Temp Code		
444T - 445T	4	4:1	20:1	6:1	1000:1	T3 (200°C)	T3C (160°C)
	2, 6, 8	4:1	20:1	NA	1000:1	T3 (200°C)	T3C (160°C)
447T	4	4:1	20:1	6:1	1000:1	T3 (200°C)	T3C (160°C)
	2, 6, 8	4:1	20:1	NA	1000:1	T3 (200°C)	T3C (160°C)
449T	2, 4, 6, 8	4:1	20:1	NA	1000:1	T3 (200°C)	T3C (160°C)
L449	2, 4, 6, 8	2:1	20:1	NA	1000:1	T3 (200°C)	T3C (160°C)

Frame Size 500							
400 - 600 HP	2	3:1	20:1	NA	NA	T3 (200°C)	T3C (160°C) ¹
	4	4:1	20:1	NA	NA	T3 (200°C)	T3C (160°C) ¹
350 - 400 HP	6	2:1	20:1	NA	NA	T3 (200°C)	T3C (160°C) ¹
700 - 800 HP	2	35-60HZ	20:1	NA	NA	T2D (215°C)	T3C (160°C) ¹
	4	2:1	20:1	NA	NA	T2D (215°C)	T3C (160°C) ¹
500 - 600 HP	6	2:1	20:1	NA	NA	T2D (215°C)	T3C (160°C) ¹

1) With option M25

4.1.2. Low Voltage NEMA Motors

4.1.2.1. GP100A, GP100

General Purpose Low Voltage NEMA Motors (GP100, GP100A)

Frame	Poles	Standard	
		Constant Torque	Variable Torque
143T - 145T	2, 4, 6	4:1	20:1
	8	4:1	20:1
182T - 184T	2, 4, 6	4:1	20:1
	8	4:1	20:1
213T - 215T	2, 4, 6	4:1	20:1
	8	4:1	20:1
254T - 256T	2, 4, 6	4:1	20:1
	8	4:1	20:1
284T - 286T	2, 4, 6	4:1	20:1
	8	4:1	20:1
324T - 326T	2, 4, 6	4:1	20:1
	8	4:1	20:1
364T - 365T	2, 4, 6	4:1	20:1
	8	4:1	20:1
404T - 405T	2, 4, 6	4:1	20:1
	8	4:1	20:1
444T - 445T	2, 4, 6	4:1	20:1
	8	4:1	20:1
447T	2, 4, 6	4:1	20:1
	8	4:1	20:1
449T	2, 4, 6	4:1	20:1
	8	4:1	20:1

4.1.2.2. SD100, SD100 IEEE, SD661

Severe Duty Low Voltage NEMA Motors (SD100, SD100IEEE, SD661)

Frame	Poles	Standard		M05 Option	C00+C03+ M08 Options	Temp Codes	
		Constant Torque	Variable Torque	Constant Torque	Constant Torque	Class I, Division 2	Class II, Division 2
						Temp Code	Temp Code
143T - 145T	2, 4, 6	20:1	20:1	NA	1000:1	T3 (200°C)	T3C (160°C) ¹
	8	4:1	20:1	NA	1000:1	T3 (200°C)	T3C (160°C) ¹
182T - 184T	2, 4, 6	20:1	20:1	NA	1000:1	T3 (200°C)	T3C (160°C) ¹
	8	4:1	20:1	NA	1000:1	T3 (200°C)	T3C (160°C) ¹
213T - 215T	2, 4, 6	20:1	20:1	NA	1000:1	T3 (200°C)	T3C (160°C) ¹
	8	4:1	20:1	NA	1000:1	T3 (200°C)	T3C (160°C) ¹
254T - 256T	2, 4, 6	20:1	20:1	NA	1000:1	T3 (200°C)	T3C (160°C) ¹
	8	4:1	20:1	NA	1000:1	T3 (200°C)	T3C (160°C) ¹
284T - 286T	2, 4, 6	20:1	20:1	NA	1000:1	T3 (200°C)	T3C (160°C)
	8	4:1	20:1	NA	1000:1	T3 (200°C)	T3C (160°C)
324T - 326T	2, 4, 6	20:1	20:1	NA	1000:1	T3 (200°C)	T3C (160°C)
	8	4:1	20:1	NA	1000:1	T3 (200°C)	T3C (160°C)
364T - 365T	2, 4, 6	20:1	20:1	NA	1000:1	T3 (200°C)	T3C (160°C)
	8	4:1	20:1	NA	1000:1	T3 (200°C)	T3C (160°C)
404T - 405T	2, 4, 6	4:1	20:1	10:1	1000:1	T3 (200°C)	T3C (160°C)
	8	4:1	20:1	NA	1000:1	T3 (200°C)	T3C (160°C)
444T - 445T	2, 4, 6	4:1	20:1	10:1	1000:1	T3 (200°C)	T3C (160°C) ¹
	8	4:1	20:1	NA	1000:1	T3 (200°C)	T3C (160°C) ¹
447T	2, 4, 6	4:1	20:1	6:1	1000:1	T3 (200°C)	T3C (160°C) ¹
	8	4:1	20:1	NA	1000:1	T3 (200°C)	T3C (160°C) ¹
449T	2, 4, 6	4:1	20:1	NA	1000:1	T3 (200°C)	T3C (160°C) ¹
	8	4:1	20:1	NA	1000:1	T3 (200°C)	T3C (160°C) ¹
S449	2, 4, 6	4:1	20:1	NA	1000:1	T2D (215°C)	T3C (160°C) ¹
	8	4:1	20:1	NA	1000:1	T2D (215°C)	T3C (160°C) ¹

1) With option M25

4.1.2.3. XP100, XP100 ID1

Explosion Proof Low Voltage NEMA Motors (XP100, XP100 ID1)

Frame	Poles	XP100				XP100 ID1		
		Standard		M05 Option	Temp Code	Standard		Temp Code
		Constant Torque	Variable Torque	Constant Torque		Constant Torque	Variable Torque	
143T - 145T	2, 4, 6	4:1	20:1	NA	T3C (160°C)	4:1	100:1	T2A (280°C)
	8	4:1	20:1	NA	T3C (160°C)	4:1	100:1	T2A (280°C)
182T - 184T	2, 4, 6	4:1	20:1	NA	T3C (160°C)	4:1	100:1	T2A (280°C)
	8	4:1	20:1	NA	T3C (160°C)	4:1	100:1	T2A (280°C)
213T - 215T	2, 4, 6	4:1	20:1	NA	T3C (160°C)	4:1	100:1	T2A (280°C)
	8	4:1	20:1	NA	T3C (160°C)	4:1	100:1	T2A (280°C)
254T - 256T	2, 4, 6	4:1	20:1	NA	T3C (160°C)	4:1	100:1	T2A (280°C)
	8	4:1	20:1	NA	T3C (160°C)	4:1	100:1	T2A (280°C)
284T - 286T	2, 4, 6	4:1	20:1	NA	T3C (160°C)	4:1	100:1	T2A (280°C)
	8	4:1	20:1	NA	T3C (160°C)	4:1	100:1	T2A (280°C)
324T - 326T	2, 4, 6	4:1	20:1	NA	T3C (160°C)	4:1	100:1	T2A (280°C)
	8	4:1	20:1	NA	T3C (160°C)	4:1	100:1	T2A (280°C)
364T - 365T	2, 4, 6	4:1 ¹	20:1	6:1	T3C (160°C)	4:1	100:1	T2A (280°C)
	8	4:1 ¹	20:1	NA	T3C (160°C)	4:1	100:1	T2A (280°C)
404T - 405T	2, 4, 6	4:1 ¹	20:1	6:1	T3C (160°C)	4:1	100:1	T2A (280°C)
	8	4:1 ¹	20:1	NA	T3C (160°C)	4:1	100:1	T2A (280°C)
444T - 445T	2, 4, 6	4:1 ¹	20:1	6:1	T3C (160°C)	4:1	100:1	T2A (280°C)
	8	4:1 ¹	20:1	NA	T3C (160°C)	4:1	100:1	T2A (280°C)
447T	2, 4, 6	4:1 ¹	20:1	NA	T3C (160°C)	4:1	100:1	T2A (280°C)
	8	4:1 ¹	20:1	NA	T3C (160°C)	4:1	100:1	T2A (280°C)
449T	2, 4, 6	4:1 ¹	20:1	NA	T3C (160°C)	4:1	100:1	T2A (280°C)
	8	4:1 ¹	20:1	NA	T3C (160°C)	4:1	100:1	T2A (280°C)

1. Only with De-rated output

4.2. Bearing tables

4.2.1. Next Generation – Bearing Sizes

4.2.1.1. SD200, SD200 841, DP200 HPS

Next Generation - Standard Bearing Information

Motor Type	Frame	Standard Bearing Size DE	Standard Bearing Size NDE
SD200, SD200 841 (2 pole)	444TS-L449TS	6315 Z C3 S0	6315 Z C3 S0
SD200, SD200 841 (2 pole)	444T-L449T	6320 Z C3 S0	6315 Z C3 S0
SD200, SD200 841 (4 pole)	444TS-L449TS	6320 Z C3 S0	6315 Z C3 S0
SD200, SD200 841 (4 pole)	444T-L449T	6320 Z C3 S0	6315 Z C3 S0
SD200, SD200 841 (4 pole)	R444T-RL449T	NU 320	6315 Z C3 S0
SD200 (2 Pole)	509-5013S	6316 Z C3 S0	6316 Z C3 S0
DP200 (2 Pole)	509-5013S	6316 Z C3 S0	6316 Z C3 S0 (Insulated)
SD200 (4,6 Pole)	509-5013/S	6322 Z C3 S0 ¹	6322 Z C3 S0 ¹
SD200	R509-R5013	NU 322	6322 Z C3 S0 ¹

1. With option L50 or L51 bearing will change to 6222 C3 S0

4.2.2. Low Voltage NEMA Motors – Bearing Sizes

4.2.2.1. GP100A, GP100, SD100, SD100 IEEE, SD661

General Purpose Low Voltage NEMA Motors - Standard Bearing Information

Motor Type	Frame	Standard Bearing Size DE	Standard Bearing Size NDE
GP100, GP100A	140T	6205 ZZ C3 S0	6205 ZZ C3 S0
GP100, GP100A	180T	6206 ZZ C3 S0	6206 ZZ C3 S0
GP100, GP100A	210T	6208 ZZ C3 S0	6208 ZZ C3 S0
GP100, GP100A	250T	6209 ZZ C3 S0	6209 ZZ C3 S0
GP100	280T/TS	6310 Z C3 S0	6210 ZZ C3 S0
GP100	320T/TS	6312 Z C3 S0	6210 ZZ C3 S0
GP100	360T/TS	6314 Z C3 S0	6214 ZZ C3 S0
GP100	400T/TS	6316 Z C3 S0	6214 ZZ C3 S0
GP100	440TS	6316 Z C3 S0	6216 ZZ C3 S0
GP100	444/445T	NU 318	6316 Z C3 S0
GP100	447/449T	NU 320	6316 Z C3 S0
GP100	B440T	6318 Z C3 S0	6216 ZZ C3 S0

Severe Duty Low Voltage NEMA Motors - Standard Bearing Information

Motor Type	Frame	Standard Bearing Size DE	Standard Bearing Size NDE	Option L65 Bearing Size DE
SD100, SD100 IEEE	140T	6205 Z C3 S0	6205 Z C3 S0	NA
SD100, SD100 IEEE	180T	6206 Z C3 S0	6206 Z C3 S0	NA
SD100, SD100 IEEE	210T	6208 Z C3 S0	6208 Z C3 S0	NU 208
SD100, SD100 IEEE	250T	6309 Z C3 S0	6309 Z C3 S0	NU 309
SD100, SD100 IEEE	280T/TS	6310 Z C3 S0	6310 Z C3 S0	NU 310
SD100, SD100 IEEE	320T/TS	6312 Z C3 S0	6312 Z C3 S0	NU 312
SD100, SD100 IEEE	360T/TS	6314 Z C3 S0	6314 Z C3 S0	NU 314
SD100, SD100 IEEE	400T/TS	6316 Z C3 S0	6316 Z C3 S0	NU 316
SD100, SD100 IEEE	B440T	6318 Z C3 S0	6316 Z C3 S0	NA
SD100, SD100 IEEE (4,6,8 Pole)	440TS	6316 Z C3 S0	6316 Z C3 S0	NA
SD100 IEEE (2 Pole)	440TS	6318 Z C3 S0	6316 Z C3 S0	NA
SD100, SD100 IEEE	444/445T	NU 318	6316 Z C3 S0	Standard
SD100, SD100 IEEE	447/449T	NU 320	6316 Z C3 S0	Standard
SD100, SD100 IEEE	S449LS	NU 320	6315 Z C3 S0	Standard
SD100, SD100 IEEE	S449SS	6315 Z C3 S0	6315 Z C3 S0	NA
SD661	210T	NU 208	6208 Z C3 S0	Standard
SD661	250T	NU 309	6309 Z C3 S0	Standard
SD661	280T	NU 310	6310 Z C3 S0	Standard
SD661	320T	NU 312	6312 Z C3 S0	Standard
SD661	360T	NU 314	6314 Z C3 S0	Standard

4.2.2.2. 4.2.2.2. XP100, XP100 ID1, SD10 MS

Explosion Proof Low Voltage NEMA Motors - Standard Bearing Information

Motor Type	Frame	Standard Bearing Size DE	Standard Bearing Size NDE	Option L65 Bearing Size DE
XP100, XP100 ID1	140T	6205 Z C3 S0	6205 Z C3 S0	NA
XPJP	180JP	6007 Z C3 S0	6206 Z C3 S0	NA
XP100, XP100 ID1	180T	6206 Z C3 S0	6206 Z C3 S0	NA
XP100, XP100 ID1	210T	6208 Z C3 S0	6208 Z C3 S0	NU 208
XPJP	215JP	6009 Z C3 S0	6208 Z C3 S0	NA
XP100, XP100 ID1	250T	6309 Z C3 S0	6309 Z C3 S0	NU 309
XP100, XP100 ID1	280T/TS	6310 Z C3 S0	6310 Z C3 S0	NU 310
XP100, XP100 ID1	320T/TS	6312 Z C3 S0	6312 Z C3 S0	NU 312
XP100, XP100 ID1	360T/TS	6314 Z C3 S0	6314 Z C3 S0	NU 314
XP100, XP100 ID1	400T/TS	6316 Z C3 S0	6316 Z C3 S0	NU 316
XP100, XP100 ID1	440TS	6316 Z C3 S0	6316 Z C3 S0	NA
XP100, XP100 ID1	R444/445T	NU 318	6316 Z C3 S0	Standard
XP100, XP100 ID1	R447/449T	NU 320	6316 Z C3 S0	Standard
XP100, XP100 ID1	B440T	6318 Z C3 S0	6316 Z C3 S0	NA

Two Speed Low Voltage NEMA Motors - Standard Bearing Information

Motor Type	Frame	Standard Bearing Size DE	Standard Bearing Size NDE	Option L65 Bearing Size DE
SD10 MS	140T	6205 ZZ C3 S0	6205 ZZ C3 S0	NA
SD10 MS	180T	6206 ZZ C3 S0	6206 ZZ C3 S0	NA
SD10 MS	210T	6208 ZZ C3 S0	6208 ZZ C3 S0	NU 208
SD10 MS	250T	6309 Z C3 S0	6309 Z C3 S0	NU 309
SD10 MS	280T/TS	6310 Z C3 S0	6310 Z C3 S0	NU 310
SD10 MS	320T/TS	6312 Z C3 S0	6312 Z C3 S0	NU 312
SD10 MS	360T/TS	6314 Z C3 S0	6314 Z C3 S0	NU 314
SD10 MS	400T/TS	6316 Z C3 S0	6316 Z C3 S0	NU 316
SD10 MS	440TS	6316 Z C3 S0	6316 Z C3 S0	NA
SD10 MS	B440T	6318 Z C3 S0	6316 Z C3 S0	NA
SD10 MS	R440T	NU 318	6316 Z C3 S0	Standard

4.2.2.3. HP100, LP100

Vertical Solid Shaft Low Voltage NEMA Motors - Standard Bearing Information

Motor Type	Frame	Standard Bearing Size DE	Standard Bearing Size NDE
HP100	180HP	6206 C3 S0	6206 C3 S0 DB
HP100	210HP	6209 C3 S0	6309 C3 S0 DB
HP100	250HP	6309 C3 S0	6309 C3 S0 DB
HP100	280HP	6310 Z C3 S0	6312 Z C3 S0
HP100	320HP	6312 Z C3 S0	6314 Z C3 S0
HP100	360HP	6316 Z C3 S0	6316 Z C3 S0
HP100	400HP	6316 Z C3 S0	6316 Z C3 S0
HP100	440HP	6316 Z C3 S0	6318 Z C3 S0
LP100	180LP	6206 C3 S0	7306 BG DB
LP100	210LP	6209 C3 S0	7309 BG DB
LP100	250LP	6309 C3 S0	7309 BG DB
LP100	280LP	6312 Z C3 S0	7311 BG DB
LP100	320LP	6312 Z C3 S0	7311 BG DB
LP100	360LP	6316 Z C3 S0	7311 BG DB
LP100	400LP	6316 Z C3 S0	7311 BG DB
LP100	440LP	6316 Z C3 S0	7311 BG DB

4.2.3. Low Voltage NEMA Motors – Rated Thrust

4.2.3.1. LP100

LP100 Thrust Table

Horse Power	Pole	Frame Size	Max radial force (lb)	Standard Thrust (3 years)		Standard Thrust (1 year)		Code K21 Extra High DOWN thrust (3 years)		Code K21 Extra High DOWN thrust (1 year)	
				Down thrust (lb)	Up thrust (lb)	Down thrust (lb)	Up thrust (lb)	Up thrust (lb)	Down thrust (lb)	Up thrust (lb)	Down thrust (lb)
3	2	182LP	24	743	750	1087	1095	225 ¹	1533	328 ¹	2227
3	4	182LP	39	927	935	1361	1369	281 ¹	1923	410 ¹	2797
3	6	213LP	51	1847	1870	2702	2725	561 ¹	3806	817 ¹	5527
5	2	184LP	34	731	738	1075	1082	222 ¹	1521	324 ¹	2215
5	4	184LP	45	917	923	1351	1357	277 ¹	1913	407 ¹	2787
5	6	215LP	62	1831	1851	2685	2705	555 ¹	3790	811 ¹	5510
7.5	2	213LP	40	1268	1288	1860	1880	386 ¹	2626	564 ¹	3819
7.5	4	213LP	66	1582	1605	2328	2351	482 ¹	3293	705 ¹	4796
7.5	6	254LP	84	1794	1825	2648	2680	548 ¹	3753	803 ¹	5473
10	2	215LP	50	1256	1277	1848	1868	383 ¹	2614	560 ¹	3807
10	4	215LP	73	1571	1593	2317	2338	478 ¹	3282	701 ¹	4785
10	6	256LP	98	1775	1805	2629	2659	542 ¹	3733	797 ¹	5454
15	2	254LP	75	1218	1251	1811	1843	375 ¹	2577	553 ¹	3769
15	4	254LP	95	1533	1562	2279	2309	469 ¹	3244	692 ¹	4747
15	6	284LPH	95	2491	2548	3682	3738	764 ¹	5221	1121 ¹	7618
20	2	256LP	92	1197	1232	1789	1824	370 ¹	2555	547 ¹	3748
20	4	256LP	120	1501	1534	2247	2281	460 ¹	3212	684 ¹	4715
20	6	286LPH	120	2455	2516	3645	3705	755 ¹	5184	1111 ¹	7581
25	2	284LPH	65	1716	1768	2541	2593	530 ¹	3608	777 ¹	5271
25	4	284LPH	108	2133	2193	3172	3233	658 ¹	4517	969 ¹	6611
25	6	324LP	155	2379	2475	3569	3665	743 ¹	5108	1099 ¹	7505
30	2	286LPH	78	1698	1753	2523	2578	526 ¹	3591	773 ¹	5253
30	4	286LPH	116	2119	2177	3158	3217	653 ¹	4503	965 ¹	6597
30	6	326LP	172	2351	2450	3541	3640	735 ¹	5080	1091 ¹	7478
40	2	324LP	98	1655	1726	2480	2551	518 ¹	3548	765 ¹	5210
40	4	324LP	140	2053	2139	3093	3179	642 ¹	4438	953 ¹	6532
40	6	364LP	186	2304	2414	3494	3605	724 ¹	5033	1081 ¹	7430
50	2	326LP	105	1641	1710	2466	2535	513 ¹	3533	760 ¹	5196
50	4	326LP	180	1994	2095	3034	3135	629 ¹	4378	940 ¹	6473
50	6	365LP	208	2265	2376	3455	3565	713 ¹	4994	1069 ¹	7391
60	2	364LP	152	1561	1670	2386	2495	501 ¹	3453	748 ¹	5115

				Standard Thrust (3 years)		Standard Thrust (1 year)		Code K21 Extra High DOWN thrust (3 years)		Code K21 Extra High DOWN thrust (1 year)	
60	4	364LP	214	1926	2057	2965	3097	617 ¹	4310	928 ¹	6404
60	6	404LP	274	2160	2310	3351	3500	693 ¹	4890	1050 ¹	7287
75	2	365LP	175	1527	1640	2352	2465	492 ¹	3419	739 ¹	5082
75	4	365LP	255	1862	2006	2902	3046	602 ¹	4246	913 ¹	6340
75	6	405LP	310	2100	2254	3290	3444	676 ¹	4829	1033 ¹	7226
100	2	405LP	230	1443	1580	2269	2406	474 ¹	3336	721 ¹	4998
100	4	405LP	303	1775	1937	2814	2976	581 ¹	4159	892 ¹	6253
100	6	444LP	353	1926	2174	3116	3364	652 ¹	4655	1009 ¹	7052
125	4	444LP	347	1630	1871	2670	2911	561 ¹	4014	873 ¹	6108
125	6	445LP	455	1755	2064	2946	3254	619 ¹	4485	976 ¹	6882
150	4	445LP	417	1518	1795	2558	2835	539 ¹	3902	850 ¹	5996
150	6	447LP	529	1605	1970	2795	3161	591 ¹	4334	948 ¹	6731
200	4	447LP	524	1321	1664	2361	2703	499 ¹	3705	810 ¹	5799
200	6	449LP	673	1324	1795	2515	2985	539 ¹	4053	895 ¹	6451
250	4	449LP	638	1109	1531	2149	2571	459 ¹	3493	771 ¹	5587
250	6	449LP	679	1298	1714	2488	2904	514 ¹	4027	871 ¹	6424

1. Momentary load

4.3. Typical performance data

4.3.1. Next Generation Low Voltage NEMA Motors

4.3.1.1. SD200, SD200 841, DP200 HPS

Severe Duty Low Voltage NEMA Motors - 60Hz | SD200/SD200 841 | NEMA Premium | Aluminum Rotor

HP	FL RPM	Frame	Current						KVA/ HP Code	Nominal Efficiency (%)			Power Factor			Torque		Locked Rotor Stall Time		NEMA Design	Approx. Weight (LBS)	
			No Load		Full Load		Locked Rotor	1/2 Load (%)		3/4 Load (%)	Full Load (%)	1/2 Load (%)	3/4 Load (%)	Full Load (%)	Full Load Lb-FT	Locked Rotor TA/TN (%)	Break Down Tk/TN (%)	Hot (sec)	Cold (sec)			
			460V	575V	460V	575V	460V	575V														
75	900	444	50	40	105	84	543	434	G	93.3	93.8	93.6	54.8	65.3	68.1	443	130	200	25	32	B	1414
100	1200	444	63	50	128	102	725	580	G	94.3	95.0	95.0	57.7	71.2	77.3	423	150	260	30	35	B	1465
100	900	445	61	49	137	110	725	580	G	93.5	93.9	93.6	51.9	62.9	68.3	593	130	200	22	30	B	1495
125	3600	444	57	46	145	116	908	726	G	94.8	95.4	95.4	70.0	80.5	85.0	185	150	300	18	23	B	1528
125	1800	444	63	50	154	123	908	726	G	95.2	95.6	95.4	66.3	76.0	80.0	366	200	280	20	25	B	1548
125	1200	445	67	54	155	124	908	726	G	94.8	95.3	95.0	62.3	74.6	79.8	530	150	245	25	35	B	1579
125	900	447	81	65	165	132	908	726	G	94.7	94.8	94.1	66.5	74.7	77.2	740	140	205	20	30	B	1720
150	3600	445	58	46	170	136	1085	868	G	95.1	95.8	95.8	75.1	83.2	86.5	218	160	290	15	18	B	1689
150	1800	445	79	63	187	150	1085	868	G	96.3	96.3	96.2	63.1	73.6	78.0	440	230	290	20	30	B	1739
150	1200	447	77	62	182	146	1085	868	G	95.1	95.6	95.8	64.9	75.9	80.7	662	150	245	28	43	B	1795
150	900	449	103	82	205	164	1085	868	G	94.9	94.8	94.1	68.8	76.1	78.1	890	140	205	20	30	B	1967
200	3600	447	75	60	225	180	1450	1160	G	95.8	96.2	96.2	75.7	83.4	86.5	294	160	280	16	20	B	1843
200	1800	447	100	80	247	198	1450	1160	G	96.3	96.3	96.2	65.0	74.9	79.0	587	220	280	18	25	B	1836
200	1200	449	112	90	243	194	1450	1160	G	95.3	95.7	95.8	63.3	74.9	80.4	883	185	270	25	32	B	2125
200	900	L449	131	105	261	209	1450	1160	G	94.9	95.0	94.5	67.4	75.6	78.4	1185	125	220	15	25	B	2579
250	3600	449	97	78	275	220	1825	1460	G	95.8	96.2	96.2	75.0	83.5	87.5	370	170	290	12	18	B	2083

HP	FL RPM	Frame	Current						KVA/ HP Code	Nominal Efficiency (%)			Power Factor			Torque			Locked Rotor Stall Time		NEMA Design	Approx. Weight (LBS)
			No Load		Full Load		Locked Rotor			1/2 Load (%)	3/4 Load (%)	Full Load (%)	1/2 Load (%)	3/4 Load (%)	Full Load (%)	Full Load Lb-FT	Locked Rotor TA/TN (%)	Break Down Tk/TN (%)	Hot (sec)	Cold (sec)		
			460V	575V	460V	575V	460V	575V														
250	1800	449	120	96	305	244	1825	1460	G	96.6	96.5	96.2	65.8	76.0	80.0	735	200	220	18	25	B	2150
250	1200	449	139	111	306	245	1825	1460	G	95.5	95.9	95.8	64.9	76.2	82.0	1109	160	260	20	25	B	2283
250	900	L449	158	114	322	258	1825	1460	G	95.1	95.3	95.0	62.3	72.2	76.2	1478	125	220	25	32	B	2853
300	3600	449	99	79	322	258	2200	1760	G	95.9	96.3	96.2	82.0	88.0	90.0	441	160	280	12	13	B	2194
300	1800	449	144	115	365	292	2200	1760	G	96.8	96.6	96.2	66.9	80.0	80.0	882	200	220	22	30	B	2250
300	1200	L449	152	121	364	291	2200	1760	G	95.7	96.0	95.8	66.7	77.5	82.9	1334	160	260	26	33	B	2830
350	3600	L449	102	82	380	304	2550	2040	G	95.5	96.1	96.2	83.4	88.5	90.0	515	170	300	20	26	B	2680
350	1800	L449	156	125	421	337	2550	2040	G	96.1	96.2	96.2	67.6	77.0	81.0	1028	235	235	25	32	B	2723
400	3600	L449	111	89	432	346	2900	2320	G	95.7	96.2	96.2	83.9	88.9	90.0	586	170	300	17	24	B	2937
400	1800	L449	183	146	487	390	2900	2320	G	96.2	96.3	96.2	66.1	76.1	80.0	1179	235	235	21	26	B	2670

4.3.1.2. SD200, DP200 HPS – FS500

Severe Duty Low Voltage NEMA Motors - 60Hz | SD200, DP200 HPS | NEMA Premium

HP	FL RPM	Frame	Current (A)						KVA/ HP Code	Nominal Efficiency (%)			Power Factor			Torque			Locked Rotor Stall Time		NEMA Design	Approx. Weight (LBS)
			No Load		Full Load		Locked Rotor			1/2 Load (%)	3/4 Load (%)	Full Load (%)	1/2 Load (%)	3/4 Load (%)	Full Load (%)	Full Load Lb-FT	Locked Rotor TA/TN (%)	Break Down Tk/TN (%)	Hot (sec)	Cold (sec)		
			460V	575V	460V	575V	460V	575V														
350	1190	5010	140	112	410	328	2550	2040	G	96.6	96.6	96.2	74.3	81.5	84.1	1543	270	250	30	35	B	4387
400	3585	509S	85	70	430	345	2900	2320	G	96	96.4	96.5	85.1	89.6	90.8	585	190	230	23	28	B	4219
400	1790	509	140	112	460	368	2900	2320	G	96.2	96.7	96.5	76.3	81.8	84.4	1174.6	230	250	19	23	B	4105
400	1190	5011	160	128	470	376	2900	2320	G	96.6	96.6	96.2	74.3	81.5	84.1	1763.5	270	250	30	35	B	4529
450	3585	5010S	100	80	480	385	3250	2600	G	96	96.4	96.5	85.1	89.6	90.8	659.3	190	230	23	28	B	4357
450	1790	5010	150	120	515	412	3250	2600	G	96.4	96.7	96.5	76.7	82.7	84.8	1325.3	230	250	17	21	B	4302
450	1190	L5011	170	136	525	420	3250	2600	G	96.6	96.6	96.2	74.3	81.5	84.1	1984	270	250	30	35	B	5083
500	3585	5011S	105	84	535	430	3625	2900	G	96	96.4	96.5	85.1	89.6	90.8	732.5	190	230	19	24	B	4504
500	1790	5011	160	128	570	456	3625	2900	G	96.5	96.8	96.7	78.2	85.3	84.9	1469.2	230	250	18	22	B	4509
500	1190	5012	185	148	580	464	3625	2900	G	96.6	96.6	96.2	74.3	81.5	84.1	2204.4	270	250	30	35	B	5289
600	3585	5012S	145	115	650	520	4250	3400	G	96.3	96.8	96.7	80.6	87	89.1	877.7	190	230	17	22	-	4936
600	1790	5012	190	152	686	549	4400	3520	G	96.6	96.9	96.7	77.5	83.6	84.7	1767.6	230	250	19	23	-	4993
600	1190	5013	245	196	695	556	4518	3614	G	96.6	96.6	96.2	74.3	81.5	84.1	2644.9	270	250	30	35	-	5391
700	3585	5013S	160	128	750	600	5285	4228	G	94.8	95.6	95.8	86.5	90.4	91.1	1025.5	250	290	23	28	-	5538
700	1790	5013	305	244	830	664	5395	4316	G	97.3	97.2	96.7	81.2	85.7	81.7	2056.3	230	250	18	22	-	5592
800	3585	5013S	210	170	870	680	6300	5040	G	95.1	96	96.2	82.4	87.7	89.4	1172	250	290	19	24	-	5798
800	1790	5013	335	268	920	736	5980	4784	G	97.4	97.2	96.7	80.9	85.6	84.2	2349.9	230	250	17	21	-	5840

4.3.2. Low Voltage NEMA Motors

4.3.2.1. GP100A, GP100

General Purpose Low Voltage NEMA Motors - 60Hz | GP100A/GP100 | NEMA Premium | Aluminum Rotor

HP	FL RPM	Frame	Current (A)									KVA/ HP Code	Nominal Efficiency (%)			Power Factor			Torque			Locked Rotor Stall Time		NEMA Design	Approx. Weight (LBS)
			No Load			Full Load			Locked Rotor				1/2 Load (%)	3/4 Load (%)	Full Load (%)	1/2 Load (%)	3/4 Load (%)	Full Load (%)	Full Load Lb-FT	Locked Rotor TA/TN (%)	Break Down Tk/TN (%)	Hot (sec)	Cold (sec)		
			230V	460V	575V	230V	460V	575V	230V	460V	575V														
1	3520	143T	1.4	0.7	0.56	2.8	1.4	1.12	24	12	9.6	L	79.3	82.1	82.5	65.2	77.4	81.1	1.5	175	380	12	16	B	70
1	1755	143T	1.6	0.8	0.64	2.8	1.4	1.12	26	13	10.4	M	83.4	85.4	85.5	58.4	71.5	78.2	3	295	380	18	26	B	58
1	1165	145T	2	1	0.8	3.2	1.6	1.28	22	11	8.8	K	80.2	82.5	82.5	50.2	63.3	70.9	4.5	260	350	18	31	B	70
1	870	182T	3	1.5	1.2	4.2	2.1	1.68	18	9	7.2	J	77	80	81.5	36	47	56	6	160	280	50	68	B	86
1.5	3525	143T	2.2	1.1	0.88	4	2	1.6	38	19	15.2	M	80	83.2	84	64.2	77	83.6	2.2	270	450	14	19	B	75
1.5	1740	145T	3	1.1	0.88	4.2	2.1	1.68	38	19	15.2	M	85.8	87	86.5	58.5	71.8	77.3	4.5	330	420	15	21	B	69
1.5	1160	182T	2.8	1.4	1.12	4.8	2.4	1.92	30	15	12	J	85.3	87.6	87.5	48.4	58.4	66.9	6.8	205	330	34	46	B	101
1.5	865	184T	4.6	2.3	1.84	6	3	2.4	34	17	13.6	L	78.5	82	82.5	35	47	56	9	160	280	43	63	B	99
2	3515	145T	2.4	1.2	0.96	5	2.5	2	46	23	18.4	L	84	85.7	85.5	69	81.3	87.6	2.9	250	420	13	18	B	55
2	1740	145T	2.2	1.5	0.88	4.2	2.8	1.68	38	24	15.2	L	86	87.2	86.5	57.8	70.8	77.3	6	320	390	14	22	B	61
2	1160	184T	3.8	1.9	1.52	6.4	3.2	2.56	40	20	16	J	87.5	88.7	88.5	46.5	58.8	66.1	9.1	240	310	23	32	B	112
2	870	213T	4	2	1.6	6.6	3.3	2.64	32	16	12.8	H	84	84.5	84	51	63	67	12	170	290	22	38	B	126
3	3520	182T	3.4	1.7	1.36	7.6	3.8	3.04	60	30	24	J	84.17	86.3	86.5	69.5	79.8	85.5	4.4	185	380	20	30	B	81
3	1760	182T	4.2	2.1	1.68	8	4	3.2	66	33	26.4	K	87.8	89.4	89.5	59.5	71.7	78.5	9	235	360	17	29	B	85
3	1175	213T	5	2.5	2	8.6	4.3	3.44	64	32	25.6	K	87.8	89.3	89.5	52.1	65.4	73	13.4	265	470	23	35	B	155
3	870	215T	6	3	2.4	9.6	4.8	3.84	50	25	20	H	85.5	86.5	85.5	45	59	68	18	175	290	19	31	B	141
5	3505	184T	4	2	1.6	12	6	4.8	92	46	36.8	J	88.2	89.1	88.5	78.1	85.9	88.2	7.5	170	420	15	29	B	109
5	1755	184T	6	3	2.4	13	6.5	5.2	92	46	36.8	J	89.2	90	89.5	63.6	75.1	80.5	15	220	350	14	29	B	90
5	1165	215T	7	3.5	3.6	13.4	6.7	5.36	92	46	36.8	J	89.5	90.1	89.5	59.4	71.4	78.1	26.5	220	380	14	21	B	171
5	880	254T	11	5.5	4.4	17	8.5	6.8	66	33	26.4	G	85.5	87	86.5	43	54	61	30	155	210	65	115	B	218
7.5	3520	213T	6	3	2.4	17.6	8.8	7.04	126	63	50.4	H	89.6	90.1	89.5	78.5	86.8	89.2	11	180	490	17	30	B	209

HP	FL RPM	Frame	Current (A)									KVA/ HP Code	Nominal Efficiency (%)			Power Factor			Torque			Locked Rotor Stall Time		NEMA Design	Approx. Weight (LBS)
			No Load			Full Load			Locked Rotor				1/2 Load (%)	3/4 Load (%)	Full Load (%)	1/2 Load (%)	3/4 Load (%)	Full Load (%)	Full Load Lb-FT	Locked Rotor TA/TN (%)	Break Down Tk/TN (%)	Hot (sec)	Cold (sec)		
			230V	460V	575V	230V	460V	575V	230V	460V	575V														
7.5	1765	213T	10	5	4	19.4	9.7	7.76	126	63	50.4	H	90.73	91.7	91.7	60.5	72.3	78.9	22	270	450	25	42	B	165
7.5	1175	254T	10	5	4	20	10	8	126	63	50.4	H	91.1	91.5	91	58.4	70.2	77.2	33	165	260	26	45	B	249
7.5	875	256T	15.8	7.9	6.32	26	13	10.4	100	50	40	G	87	88	87.5	44	55	62	45	165	200	50	100	B	250
10	3515	215T	7	3.5	2.8	23	11.5	9.2	162	81	64.8	H	91	91.1	90.2	81.5	88.8	90.3	15	180	440	14	28	B	208
10	1755	215T	12.2	6.1	4.88	25	12.5	10	162	81	64.8	H	91.7	92.2	91.7	63.8	76.2	81.7	30	270	410	20	36	B	166
10	1175	256T	12.6	6.3	5.04	27	13.5	10.8	162	81	64.8	H	91.4	91.6	91	61	71.6	76.2	45	165	250	18	38	B	258
10	885	284T	22	11	8.8	34	17	13.6	162	81	64.8	H	88.2	89.8	90.2	42	53	61	59	160	240	15	30	B	418
15	3530	254T	10.2	5.1	4.08	35	17.5	14	232	116	92.8	G	90.7	91.3	91	80.6	87.4	88.2	22	210	260	24	48	B	301
15	1770	254T	17	8.5	6.8	38	19	15.2	232	116	92.8	G	92.3	92.8	92.4	64.5	74.7	80	44	185	235	21	33	B	242
15	1180	284T	22	11	8.8	42	21	16.8	232	116	92.8	G	90.9	91.8	91.7	53	66	73	67	150	240	22	48	B	409
15	885	286T	28	14	11.2	46	23	18.4	232	116	92.8	G	89.4	90.6	91	47	59	66	89	160	240	18	35	B	459
20	3515	256T	10.4	5.2	4.16	45	22.5	18	290	145	116	G	92.1	91.6	91	86.2	91.3	91.5	30	185	230	20	45	B	313
20	1770	256T	21	10.5	8.4	50	25	20	290	145	116	G	93.1	93.4	93	65.3	75.9	80.5	60	185	240	15	33	B	266
20	1180	286T	26	13	10.4	54	27	21.6	290	145	116	G	91.2	92	91.7	57	69	76	89	150	240	20	45	B	434
20	885	324T	36	18	14.4	64	32	25.6	290	145	116	G	90	90.8	91	46	58	65	119	140	200	15	35	B	616
25	3525	284TS	14	7	5.6	58	29	23.2	366	183	146.4	G	91.4	92.2	91.7	81	86	88	37	160	250	16	30	B	465
25	1775	284T	22	11	8.8	60	30	24	366	183	146.4	G	93.5	94	93.6	71	80	84	74	180	250	24	44	B	445
25	1185	324T	28	14	11.2	66	33	26.4	366	183	146.4	G	92.7	93.2	93	62	72	76	111-	170	240	28	54	B	633
25	885	326T	44	22	17.6	80	40	32	366	183	146.4	G	90.4	91.2	91	48	59	65	149	150	200	22	40	B	663

General Purpose Low Voltage NEMA Motors - 60Hz | GP100A/GP100 | NEMA Premium | Aluminum Rotor

HP	FL RPM	Frame	Current (A)									KVA/ HP Code	Nominal Efficiency (%)			Power Factor			Torque		Locked Rotor Stall Time		NEMA Design	Approx. Weight (LBS)	
			No Load			Full Load			Locked Rotor				1/2 Load (%)	3/4 Load (%)	Full Load (%)	1/2 Load (%)	3/4 Load (%)	Full Load (%)	Full Load Lb-FT	Locked Rotor TA/TN (%)	Break Down Tk/TN (%)	Hot (sec)			Cold (sec)
			230V	460V	575V	230V	460V	575V	230V	460V	575V														
30	3530	286TS	17	8.5	6.8	68	34	27.2	436	218	174.4	G	91.4	92.2	91.7	84	89	90	45	160	250	16	30	B	424
30	1775	286T	24	12	9.6	70	35	28	436	218	174.4	G	93.9	94.1	93.6	73	82	85	89	180	250	24	44	B	456
30	1185	326T	30	15	12	78	39	31.2	436	218	174.4	G	93.1	93.5	93	61	73	77	133	170	220	26	52	B	658
30	885	364T	52	26	20.8	94	47	37.6	436	218	174.4	G	90.6	92	91.7	49	61	65	178	150	200	22	40	B	854
40	3535	324TS	24	12	9.6	90	45	36	580	290	232	G	94	94.1	93.6	80	87	89	60	150	250	22	45	B	608
40	1780	324T	30	15	12	92	46	36.8	580	290	232	G	94.3	94.1	94.1	75	83	86	118	180	230	22	45	B	636
40	1185	364T	38	19	15.2	98	49	39.2	580	290	232	G	94.4	94.6	94.1	68	77	81	177	190	220	29	55	B	828
40	885	365T	72	36	28.8	126	63	50.4	580	290	232	G	90.7	92	91.7	49	60	65	237	150	200	25	40	B	950
50	3535	326TS	30	15	12	110	55	44	726	363	290.4	G	93.8	94.1	93.6	82	89	91	74	150	250	18	37	B	593
50	1780	326T	40	20	16	116	58	46.4	726	363	290.4	G	94.8	95	94.5	72	81	85	148	170	230	22	45	B	700
50	1185	365T	48	24	19.2	124	62	49.6	726	363	290.4	G	94	94.3	94.1	67	76	80	222	190	220	29	55	B	863
50	885	404T	56	28	22.4	134	67	53.6	726	363	290.4	G	93	93.1	92.4	64	73	76	297	140	200	25	40	B	111-6
60	3565	364TS	38	19	15.2	136	68	54.4	870	435	348	G	93.8	94.1	93.6	80	86	88	89	160	250	16	28	B	780
60	1780	364T	42	21	16.8	136	68	54.4	870	435	348	G	95.2	95.4	95	77	85	87	177	180	240	26	38	B	903
60	1185	404T	56	28	22.4	148	74	59.2	870	435	348	G	94.2	94.7	94.5	65	76	80	266	180	220	25	50	B	1047
60	885	405T	60	30	24	156	78	62.4	870	435	348	G	93	93.1	92.4	66	75	78	356	140	200	30	35	B	1182
75	3565	365TS	44	22	17.6	172	86	68.8	1086	543	434.4	G	93.7	94.3	94.1	81	86	88	111-	160	260	16	27	B	888
75	1780	365T	50	25	20	170	85	68	1086	543	434.4	G	95.6	95.8	95.4	78	85	87	221	180	240	25	35	B	950
75	1185	405T	68	34	27.2	186	93	74.4	1086	543	434.4	G	94.7	94.9	94.5	68	77	80	332	180	220	33	45	B	1257
75	885	444T	74	37	29.6	188	94	75.2	1086	543	434.4	G	93.5	93.9	93.6	67	76	80	445	135	200	25	32	B	1557
100	3570	405TS	-	19	15.2	-	108	86.4	-	725	580	G	94.6	94.7	94.1	89	91	92	147	120	200	25	45	B	1097
100	1780	405T	-	30	24	-	113	90.4	-	725	580	G	95.8	96	95.4	80	86	87	295	180	200	25	35	B	1097
100	1185	444T	-	39	31.2	-	117	93.6	-	725	580	G	95.1	95.3	95	73	81	84	443	160	200	30	35	B	1550

HP	FL RPM	Frame	Current (A)									KVA/ HP Code	Nominal Efficiency (%)			Power Factor			Torque			Locked Rotor Stall Time		NEMA Design	Approx. Weight (LBS)
			No Load			Full Load			Locked Rotor				1/2 Load (%)	3/4 Load (%)	Full Load (%)	1/2 Load (%)	3/4 Load (%)	Full Load (%)	Full Load Lb-FT	Locked Rotor TA/TN (%)	Break Down Tk/TN (%)	Hot (sec)	Cold (sec)		
			230V	460V	575V	230V	460V	575V	230V	460V	575V														
100	885	445T	-	48	38.4	-	123	98.4	-	725	580	G	94.2	94.5	94.1	70	78	81	593	130	200	22	30	B	1697
125	3575	444TS	-	32	25.6	-	138	110.4	-	908	726.4	G	94.5	95.1	95	84	88	89	184	120	200	18	23	B	1381
125	1785	444T	-	45	36	-	143	114.4	-	908	726.4	G	95.4	95.6	95.4	78	84	86	368	160	200	20	25	B	1601
125	1185	445T	-	48	38.4	-	144	115.2	-	908	726.4	G	95.1	95.4	95	74	82	85	554	160	200	25	35	B	1766
125	885	447T	-	54	43.2	-	152	121.6	-	908	726.4	G	94.6	94.7	94.1	70	79	82	742	130	200	20	30	B	2018
150	3575	445TS	-	37	29.6	-	164	131.2	-	1085	868	G	94.2	95	95	84	89	90	220	120	200	15	18	B	1601
150	1785	445T	-	52	41.6	-	170	136	-	1085	868	G	95.7	96	95.8	78	84	86	441	150	200	20	30	B	1753
150	1190	447T	-	59	47.2	-	172	137.6	-	1085	868	G	95.6	96	95.8	73	82	85	662	140	200	28	43	B	2006
200	3575	445TS	-	44	29.6	-	216	131.2	-	1450	868	G	95.3	95.6	95.4	83	90	91	294	120	200	16	20	B	1916
200	1785	445T	-	73	41.6	-	228	136	-	1450	868	G	96.2	96.5	96.2	75	83	85	588	160	200	18	25	B	2083
200	1190	447T	-	73	47.2	-	227	137.6	-	1450	868	G	95.6	96.2	95.8	75	83	86	883	125	200	25	32	B	2451

4.3.2.2. SD100, SD100 IEEE, SD661

Severe Duty Low Voltage NEMA Motors - 60Hz | SD100/SD100 IEEE841/SD661 | NEMA Premium Aluminum Rotor

HP	FL RPM	Frame	Current (A)									KVA/ HP Code	Nominal Efficiency (%)			Power Factor			Torque			Locked Rotor Stall Time		NEMA Design	Approx. Weight (LBS)
			No Load			Full Load			Locked Rotor				1/2 Load (%)	3/4 Load (%)	Full Load (%)	1/2 Load (%)	3/4 Load (%)	Full Load (%)	Full Load Lb-FT	Locked Rotor TA/TN (%)	Break Down Tk/TN (%)	Hot (sec)	Cold (sec)		
			230V	460V	575V	230V	460V	575V	230V	460V	575V														
1	3520	143T	1.4	0.70	0.56	2.8	1.4	1.1	24	12	10	L	79.3	82.1	82.5	65.2	77.4	81.1	1.5	175	380	12	16	B	85
1	1755	143T	1.6	0.80	0.64	2.8	1.4	1.1	26	13	10	M	83.4	85.4	85.5	58.4	71.5	78.2	3	295	380	18	26	B	72
1	1165	145T	2.0	1.0	0.80	3.2	1.6	1.3	22	11	9	K	80.2	82.5	82.5	50.2	63.3	70.9	4.5	260	350	18	31	B	70
1	870	182T	3.0	1.5	1.2	4.2	2.1	1.7	18	9	7	J	77	80	81.5	36	47	56	6	160	280	50	68	B	106
1.5	3525	143T	2.2	1.1	0.88	4.0	2.0	1.6	38	19	15	M	80	83.2	84	64.2	77	83.6	2.2	270	450	14	19	B	44
1.5	1740	145T	2.2	1.1	0.88	4.2	2.1	1.7	38	19	15	M	85.8	87	86.5	58.5	71.8	77.3	4.5	330	420	15	21	B	83
1.5	1160	182T	2.8	1.4	1.1	4.8	2.4	1.9	30	15	12	J	85.3	87.6	87.5	48.4	58.4	66.9	6.8	205	330	34	46	B	121
1.5	865	184T	4.6	2.3	1.8	6.0	3.0	2.4	34	17	14	L	78.5	82	82.5	35	47	56	9	160	280	43	63	B	119
2	3515	145T	2.4	1.2	1.0	5.0	2.5	2.0	46	23	18	L	84	85.7	85.5	69	81.3	87.6	2.9	250	420	13	18	B	69
2	1740	145T	3.0	1.5	1.2	5.6	2.8	2.2	48	24	19	L	86	87.2	86.5	57.8	70.8	77.3	6	320	390	14	22	B	75
2	1160	184T	3.8	1.9	1.5	6.4	3.2	2.6	40	20	16	J	87.5	88.7	88.5	46.5	58.8	66.1	9.1	240	310	23	32	B	133
2	870	213T	4.0	2.0	1.6	6.6	3.3	2.6	32	16	13	H	84	84.5	84	51	63	67	12	170	290	22	38	B	145
3	3520	182T	3.4	1.7	1.4	7.6	3.8	3.0	60	30	24	J	84.17	86.3	86.5	69.5	79.8	85.5	4.4	185	380	20	30	B	135
3	1760	182T	4.2	2.1	1.7	8.0	4.0	3.2	66	33	26	K	87.8	89.4	89.5	59.5	71.7	78.5	9	235	360	17	29	B	132
3	1175	213T	5.0	2.5	2.0	8.6	4.3	3.4	64	32	26	K	87.8	89.3	89.5	52.1	65.4	73	13.4	265	470	23	35	B	176
3	870	215T	6.0	3.0	2.4	9.6	4.8	3.8	50	25	20	H	85.5	86.5	85.5	45	59	68	18	175	290	19	31	B	160
5	3505	184T	4.0	2.0	1.6	12.0	6.0	4.8	92	46	37	J	88.2	89.1	88.5	78.1	85.9	88.2	7.5	170	420	15	29	B	129
5	1755	184T	6.0	3.0	2.4	13.0	6.5	5.2	92	46	37	J	89.2	90	89.5	63.6	75.1	80.5	15	220	350	14	29	B	135
5	1165	215T	7.0	3.5	3.6	13.4	6.7	5.4	92	46	37	J	89.5	90.1	89.5	59.4	71.4	78.1	26.5	220	380	14	21	B	191
5	880	254T	11.0	5.5	4.4	17.0	8.5	6.8	66	33	26	G	85.5	87	86.5	43	54	61	30	155	210	65	115	B	247
7.5	3520	213T	6.0	3.0	2.4	17.6	8.8	7.0	126	63	50	H	89.6	90.1	89.5	78.5	86.8	89.2	11	180	490	17	30	B	161
7.5	1765	213T	10.0	5.0	4.0	19.4	9.7	7.8	126	63	50	H	90.73	91.7	91.7	60.5	72.3	78.9	22	270	450	25	42	B	175

HP	FL RPM	Frame	Current (A)									KVA/ HP Code	Nominal Efficiency (%)			Power Factor			Torque			Locked Rotor Stall Time		NEMA Design	Approx. Weight (LBS)
			No Load			Full Load			Locked Rotor				1/2 Load (%)	3/4 Load (%)	Full Load (%)	1/2 Load (%)	3/4 Load (%)	Full Load (%)	Full Load Lb-FT	Locked Rotor TA/TN (%)	Break Down Tk/TN (%)	Hot (sec)	Cold (sec)		
			230V	460V	575V	230V	460V	575V	230V	460V	575V														
7.5	1175	254T	10.0	5.0	4.0	20.0	10.0	8.0	126	63	50	H	91.1	91.5	91	58.4	70.2	77.2	33	165	260	26	45	B	278
7.5	875	256T	15.8	7.9	6.3	26.0	13.0	10.4	100	50	40	G	87	88	87.5	44	55	62	45	165	200	50	100	B	279
10	3515	215T	7.0	3.5	2.8	23.0	11.5	9.2	162	81	65	H	91	91.1	90.2	81.5	88.8	90.3	15	180	440	14	28	B	218
10	1755	215T	12.2	6.1	4.9	25.0	12.5	10.0	162	81	65	H	91.7	92.2	91.7	63.8	76.2	81.7	30	270	410	20	36	B	180
10	1175	256T	12.6	6.3	5.0	27.0	13.5	10.8	162	81	65	H	91.4	91.6	91	61	71.6	76.2	45	165	250	18	38	B	385
10	875	284T	18.2	9.1	7.3	30.0	15.0	12.0	162	81	65	H	89.4	90.9	91	50	61	69	60	150	220	15	30	B	361
15	3530	254T	10.2	5.1	4.1	35.0	17.5	14.0	232	116	93	G	90.7	91.3	91	80.6	87.4	88.2	22	210	260	24	48	B	331
15	1770	254T	17.0	8.5	6.8	38.0	19.0	15.2	232	116	93	G	92.3	92.8	92.4	64.5	74.7	80	44	185	235	21	33	B	286
15	1180	284T	22.0	11.0	8.8	42.0	21.0	16.8	232	116	93	G	90.9	91.8	91.7	53	66	73	67	150	240	22	48	B	440
15	875	286T	28.0	14.0	11.2	46.0	23.0	18.4	232	116	93	G	90.1	91.4	91	50	60	67	90	150	220	18	35	B	430
20	3515	256T	10.4	5.2	4.2	45.0	22.5	18.0	290	145	116	G	92.1	91.6	91	86.2	91.3	91.5	30	185	230	20	45	B	343
20	1770	256T	21.0	11.0	8.0	50.0	25.0	20.0	290	145	116	G	93.1	93.4	93	65.3	75.9	80.5	60	185	240	15	33	B	319
20	1180	286T	26.0	13.0	10.4	54.0	27.0	21.6	290	145	116	G	91.2	92	91.7	57	69	76	89	150	240	20	45	B	462
20	880	324T	36.0	18.0	14.4	62.0	31.0	24.8	290	145	116	G	90	91.2	91	50	61	67	119	140	200	15	35	B	567
25	3525	284TS	16.0	8.0	6.4	58.0	29.0	23.2	366	183	146	G	92	92.2	91.7	80	85	88	37	160	250	16	30	B	396
25	1775	284T	22.0	11.0	8.8	60.0	30.0	24.0	366	183	146	G	93.5	94	93.6	71	80	84	74	180	250	24	44	B	445
25	1185	324T	28.0	14.0	11.2	66.0	33.0	26.4	366	183	146	G	92.7	93.2	93	62	72	76	111-	170	240	28	54	B	623
25	880	326T	44.0	22.0	17.6	76.0	38.0	30.4	366	183	146	G	89.2	90.5	90.2	50	61	68	149	150	200	22	40	B	600

Severe Duty Low Voltage NEMA Motors - 60Hz | SD100/SD100 IEEE841/SD661 | NEMA Premium Aluminum Rotor

HP	FL RPM	Frame	Current (A)									KVA/ HP Code	Nominal Efficiency (%)			Power Factor			Torque		Locked Rotor Stall Time		NEMA Design	Approx. Weight (LBS)	
			No Load			Full Load			Locked Rotor				1/2 Load (%)	3/4 Load (%)	Full Load (%)	1/2 Load (%)	3/4 Load (%)	Full Load (%)	Full Load Lb-FT	Locked Rotor TA/TN (%)	Break Down Tk/TN (%)	Hot (sec)			Cold (sec)
			230V	460V	575V	230V	460V	575V	230V	460V	575V														
30	3525	286TS	19	10	8	68	34	27	436	218	174	G	92	92.2	91.7	84	89	90	45	160	250	16	30	B	430
30	1775	286T	24	12	10	70	35	28	436	218	174	G	93.9	94.1	93.6	73	82	85	89	180	250	24	44	B	478
30	1185	326T	30	15	12	78	39	31	436	218	174	G	93.1	93.5	93	64	73	77	133	170	220	26	52	B	654
30	885	364T	52	26	21	94	47	38	436	218	174	G	89.9	91.3	91	50	62	66	178	150	200	22	40	B	800
40	3535	324TS	24	12	10	90	45	36	580	290	232	G	94	94.1	93.6	80	87	89	60	150	250	22	45	B	539
40	1780	324T	30	15	12	92	46	37	580	290	232	G	94.3	94.1	94.1	75	83	86	118	180	230	22	45	B	632
40	1185	364T	36	18	14	98	49	39	580	290	232	G	94.4	94.1	94.1	70	79	81	177	190	220	29	55	B	839
40	885	365T	72	36	29	126	63	50	580	290	232	G	90.7	92	91.7	49	60	65	237	150	200	25	40	B	920
50	3535	326TS	30	15	12	110	55	44	726	363	290	G	93.8	94.1	93.6	82	89	91	74	150	250	18	37	B	573
50	1780	326T	38	19	15	116	58	46	726	363	290	G	94.8	95	94.5	74	82	85	148	170	230	22	45	B	700
50	1185	365T	48	24	19	124	62	50	726	363	290	G	94	94.3	94.1	67	76	80	222	190	220	29	55	B	883
50	885	404T	56	28	22	134	67	54	726	363	290	G	93	93.1	92.4	64	73	76	297	140	200	25	40	B	111-6
60	3565	364TS	38	19	15	136	68	54	870	435	348	G	93.8	94.1	93.6	80	86	88	89	160	250	16	28	B	740
60	1780	364T	38	19	15	136	68	54	870	435	348	G	95.2	95.4	95	77	85	87	177	180	240	26	38	B	936
60	1185	404T	56	28	22	148	74	59	870	435	348	G	94.2	94.7	94.5	65	76	80	266	180	220	25	50	B	1100
60	885	405T	60	30	24	156	78	62	870	435	348	G	93	93.1	92.4	66	75	78	356	140	200	30	35	B	1182
75	3565	365TS	44	22	18	172	86	69	-	543	434	G	93.7	94.3	94.1	81	86	88	111-	160	260	16	27	B	817
75	1780	365T	50	25	20	170	85	68	1086	543	434	G	95.6	95.8	95.4	78	85	87	221	180	240	25	35	B	1000
75	1185	405T	68	34	27	186	93	74	1086	543	434	G	94.7	94.9	94.5	68	77	80	332	180	220	33	45	B	1257

HP	FL RPM	Frame	Current (A)									KVA/ HP Code	Nominal Efficiency (%)			Power Factor			Torque		Locked Rotor Stall Time		NEMA Design	Approx. Weight (LBS)	
			No Load			Full Load			Locked Rotor				1/2 Load (%)	3/4 Load (%)	Full Load (%)	1/2 Load (%)	3/4 Load (%)	Full Load (%)	Full Load Lb-FT	Locked Rotor TA/TN (%)	Break Down Tk/TN (%)	Hot (sec)			Cold (sec)
			230V	460V	575V	230V	460V	575V	230V	460V	575V														
75	885	444T	74	37	30	188	94	75	1086	543	434	G	93.5	93.9	93.6	67	76	80	445	135	200	25	32	B	1557
100	3570	405TS	-	19	15	-	108	86	-	725	580	G	94.6	94.7	94.1	90	92	92	147	120	200	25	45	B	1097
100	1780	405T	-	30	24	-	113	90	-	725	580	G	95.8	96	95.4	80	86	87	295	180	200	25	35	B	1101
100	1185	444T	-	39	31	-	117	94	-	725	580	G	95.1	95.3	95	73	81	84	443	160	200	30	35	B	1550
100	885	445T	-	48	38	-	123	98	-	725	580	G	94.2	94.5	94.1	70	78	81	593	130	200	22	30	B	1697
125	3575	444TS	-	32	26	-	138	110	-	908	726	G	94.5	95.1	95	84	88	89	184	120	200	18	23	B	1454
125	1785	444T	-	45	36	-	143	114	-	908	726	G	95.4	95.6	95.4	78	84	86	368	160	200	20	25	B	1601
125	1185	445T	-	48	38	-	144	115	-	908	726	G	95.1	95.4	95	74	82	85	554	160	200	25	35	B	1766
125	885	447T	-	54	43	-	152	122	-	908	726	G	94.6	94.7	94.1	70	79	82	742	130	200	20	30	B	2018

Severe Duty Low Voltage NEMA Motors - 60Hz | SD100/SD100 IEEE841/SD661 | NEMA Premium Aluminum Rotor

HP	FL RPM	Frame	Current (A)									KVA/ HP Code	Nominal Efficiency (%)			Power Factor			Torque		Locked Rotor Stall Time		NEMA Design	Approx. Weight (LBS)	
			No Load			Full Load			Locked Rotor				1/2 Load (%)	3/4 Load (%)	Full Load (%)	1/2 Load (%)	3/4 Load (%)	Full Load (%)	Full Load Lb-FT	Locked Rotor TA/TN (%)	Break Down Tk/TN (%)	Hot (sec)			Cold (sec)
			230V	460V	575V	230V	460V	575V	230V	460V	575V														
150	3575	445TS	-	37	29.6	-	164	131.2	-	1085	868	G	94.8	95.2	95	84	89	90	220	120	200	15	18	B	1601
150	1785	445T	-	52	41.6	-	170	136	-	1085	868	G	95.7	96	95.8	78	84	86	441	150	200	20	30	B	1753
150	1190	447T	-	59	47.2	-	172	137.6	-	1085	868	G	95.6	96	95.8	73	82	85	662	140	200	28	43	B	2006

HP	FL RPM	Frame	Current (A)									KVA/ HP Code	Nominal Efficiency (%)			Power Factor			Torque			Locked Rotor Stall Time		NEMA Design	Approx. Weight (LBS)
			No Load			Full Load			Locked Rotor				1/2 Load (%)	3/4 Load (%)	Full Load (%)	1/2 Load (%)	3/4 Load (%)	Full Load (%)	Full Load Lb-FT	Locked Rotor TA/TN (%)	Break Down Tk/TN (%)	Hot (sec)	Cold (sec)		
			230V	460V	575V	230V	460V	575V	230V	460V	575V														
150	885	449T	-	72	57.6	-	186	148.8	-	1085	868	G	94.1	94.5	94.1	0.67	0.76	0.8	890	130	200	20	30	B	2018
200	3575	445TS	-	44	35.2	-	216	172.8	-	1450	1160	G	95.3	95.6	95.4	88	90	91	294	120	200	16	20	B	1916
200	1785	445T	-	70	56	-	226	180.8	-	1450	1160	G	96.2	96.5	96.2	76	84	86	588	160	200	18	25	B	2083
200	1190	447T	-	73	58.4	-	227	181.6	-	1450	1160	G	95.6	96.2	95.8	75	83	86	883	125	200	25	32	B	2451
200	885	S449LS	-	78	62.4	-	240	192	-	1450	1160	G	95	95	94.5	71	79	83	1187	125	200	15	25	B	3200
250	3575	449TS	-	45	36	-	265	212	-	1825	1460	G	95.7	96	95.8	89	91	91	368	120	200	12	18	B	2272
250	1785	449T	-	90	72	-	278	222.4	-	2100	1680	H	96.1	96.3	96.2	78	85	87	735	140	200	18	25	A	2435
250	1190	449T	-	86	68.8	-	281	224.8	-	2050	1640	H	95.7	96	95.8	81	86	87	1104	120	200	20	25	A	2438
250	885	S449LS	-	109	87.2	-	303	242.4	-	1825	1460	G	94.5	94.8	94.5	70	78	82	1483	105	200	25	32	B	3220
300	3570	449TS	-	68	54.4	-	325	260	-	2200	1760	G	95.2	95.8	95.8	86	90	91	441	100	200	12	13	B	2200
300	1785	449T	-	114	91.2	-	338	270.4	-	2400	1920	H	96.1	96.3	96.2	75	83	86	882	140	200	22	30	A	2455
300	1185	S449LS	-	119	95.2	-	340	272	-	2400	1920	H	96	96.1	95.8	82	85	86	1329	105	200	26	33	A	3240
350	3570	S449SS	-	68	54.4	-	370	296	-	2550	2040	G	95.8	96.1	95.8	89	91	92	515	80	200	20	26	B	2890
350	1785	S449LS	-	115	92	-	390	312	-	2550	2040	G	95.8	96.3	96.2	77	84	86	1029	100	200	25	32	B	3550
400	3570	S449SS	-	80	64	-	422	337.6	-	2900	2320	G	94.6	96.1	95.8	89	92	93	588	80	200	17	24	B	3065
400	1785	S449LS	-	130	104	-	454	363.2	-	2900	2320	G	96	96.4	96.2	77	84	86	1176	100	200	21	26	B	3240

4.3.2.3. XP100, XP100 ID1

Explosion Proof Low Voltage NEMA Motors – 60Hz | XP100/XP100 ID1 | NEMA Premium

HP	FL RPM	Frame	Current (A)									KVA/ HP Code	Nominal Efficiency (%)			Power Factor			Torque			Locked Rotor Stall Time		NEMA Design	Approx. Weight (LBS)
			No Load			Full Load			Locked Rotor				1/2 Load (%)	3/4 Load (%)	Full Load (%)	1/2 Load (%)	3/4 Load (%)	Full Load (%)	Full Load Lb-FT	Locked Rotor TA/TN (%)	Break Down Tk/TN (%)	Hot (sec)	Cold (sec)		
			230V	460V	575V	230V	460V	575V	230V	460V	575V														
1	1760	143T	1.4	0.7	0.56	2.8	1.4	1.12	27.4	13.7	10.96	M	83.4	85.4	85.5	58.4	71.5	78.2	3	295	380	18	26	B	77
1	1165	145T	2	1	0.8	3.2	1.6	1.28	22	11	8.8	K	80.2	82.5	82.5	50.2	63.3	70.9	4.5	260	350	18	31	B	88
1	870	182T	3	1.5	1.2	4.2	2.1	1.68	18	9	7.2	J	77	80	81.5	36	47	56	8	160	280	50	68	B	105
1.5	3525	143T	2.2	1.1	0.88	4	2	1.6	38	19	15.2	M	80	83.2	84	64.2	77	83.6	2.2	270	450	14	19	B	55
1.5	1740	145T	2.2	1.1	0.88	4.2	2.1	1.68	38	19	15.2	M	85.8	87	86.5	58.5	71.8	77.3	4.5	330	420	15	21	B	88
1.5	1160	182T	2.8	1.4	1.12	4.8	2.4	1.92	32	16	12.8	K	85.3	87.6	87.5	48.4	58.4	66.9	6.8	205	330	34	46	B	105
1.5	865	184T	4.6	2.3	1.84	6	3	2.4	34	17	13.6	L	78.5	82	82.5	35	47	56	12	160	280	43	63	B	125
2	3515	145T	2.4	1.2	0.96	5	2.5	2	46	23	18.4	L	84	85.7	85.5	69	81.3	87.6	2.9	250	420	13	18	B	65
2	1740	145T	3	1.5	1.2	5.4	2.7	2.16	48	24	19.2	L	86	87.2	86.5	57.8	70.8	77.3	6	320	390	14	22	B	88
2	1160	184T	3.8	1.9	1.52	6.4	3.2	2.56	40	20	16	J	87.5	88.7	88.5	46.5	58.8	66.1	9.1	240	310	23	32	B	125
2	870	213T	4	2	1.6	6.6	3.3	2.64	32	16	12.8	H	84	84.5	84	51	63	67	16	170	290	22	38	B	161
3	3520	182T	3.4	1.7	1.36	7.6	3.8	3.04	60	30	24	J	84.17	86.3	86.5	69.5	79.8	85.5	4.4	185	380	20	30	B	110
3	1760	182T	4.2	2.1	1.68	8	4	3.2	66	33	26.4	K	87.8	89.4	89.5	59.5	71.7	78.5	9	235	360	17	29	B	120
3	1175	213T	5	2.5	2	8.6	4.3	3.44	64	32	25.6	K	87.8	89.3	89.5	52.1	65.4	73	13.4	265	470	23	35	B	175
3	870	215T	6	3	2.4	9.6	4.8	3.84	50	25	20	H	85.5	86.5	85.5	45	59	68	24	175	290	19	31	B	173
5	3505	184T	4	2	1.6	12	6	4.8	92	46	36.8	J	88.2	89.1	88.5	78.1	85.9	88.2	7.5	170	420	15	29	B	105
5	1755	184T	6	3	2.4	12.8	6.4	5.12	100	50	40	J	89.2	90	89.5	63.6	75.1	80.5	15	220	350	14	29	B	125
5	1165	215T	7	3.5	3.6	13.4	6.7	5.36	92	46	36.8	J	89.5	90.1	89.5	59.4	71.4	78.1	26.5	220	380	14	21	B	180
5	880	254T	11	5.5	4.4	17.6	8.8	7.04	66	33	26.4	G	85.5	87	86.5	43	54	61	41	155	210	65	115	B	270
7.5	3520	213T	6	3	2.4	17.6	8.8	7.04	126	63	50.4	H	89.6	90.1	89.5	78.5	86.8	89.2	11	180	490	17	30	B	165
7.5	1765	213T	10	5	4	19.4	9.7	7.76	126	63	50.4	H	90.73	91.7	91.7	60.5	72.3	78.9	22	270	450	25	42	B	192
7.5	1175	254T	10	5	4	20	10	8	126	63	50.4	H	91.1	91.5	91	58.4	70.2	77.2	33	165	260	26	45	B	272
7.5	875	256T	15.8	7.9	6.32	25	12.5	10	100	50	40	G	87	88	87.5	0.44	0.55	0.62	61	165	200	50	100	B	300

HP	FL RPM	Frame	Current (A)									KVA/ HP Code	Nominal Efficiency (%)			Power Factor			Torque			Locked Rotor Stall Time		NEMA Design	Approx. Weight (LBS)
			No Load			Full Load			Locked Rotor				1/2 Load (%)	3/4 Load (%)	Full Load (%)	1/2 Load (%)	3/4 Load (%)	Full Load (%)	Full Load Lb-FT	Locked Rotor TA/TN (%)	Break Down Tk/TN (%)	Hot (sec)	Cold (sec)		
			230V	460V	575V	230V	460V	575V	230V	460V	575V														
10	3515	215T	7	3.5	2.8	23	11.5	9.2	162	81	64.8	H	91	91.1	90.2	81.5	88.8	90.3	15	180	440	14	28	B	185
10	1755	215T	12.2	6.1	4.88	25	12.5	10	162	81	64.8	H	91.7	92.2	91.7	63.8	76.2	81.7	30	270	410	20	36	B	200
10	1175	256T	12.6	6.3	5.04	27	13.5	10.8	162	81	64.8	H	91.4	91.6	91	61	71.6	76.2	45	165	250	18	38	B	308
10	885	284T	22	11	8.8	34	17	13.6	162	81	64.8	H	88.2	89.8	90.2	42	53	61	59	160	240	15	30	B	486
15	3530	254T	10.2	5.1	4.08	35	17.5	14	232	116	92.8	G	90.7	91.3	91	80.6	87.4	88.2	22	210	260	24	48	B	283
15	1770	254T	17	8.5	6.8	38	19	15.2	232	116	92.8	G	92.3	92.8	92.4	64.5	74.7	80	44	185	235	21	33	B	315
15	1180	284T	22	11	8.8	42	21	16.8	232	116	92.8	G	90.9	91.8	91.7	53	66	73	67	150	240	22	48	B	484
15	885	286T	28	14	11.2	46	23	18.4	232	116	92.8	G	89.4	90.6	91	47	59	66	89	160	240	18	35	B	531
20	3515	256T	10.4	5.2	4.16	45	22.5	18	290	145	116	G	92.1	91.6	91	86.2	91.3	91.5	30	185	230	20	45	B	308
20	1770	256T	20.96	10.48	8.38	50	25	20	290	145	116	G	93.1	93.4	93	65.3	75.9	80.5	60	185	240	15	33	B	345
20	1180	286T	26	13	10.4	54	27	21.6	290	145	116	G	91.2	92	91.7	57	69	76	89	150	240	20	45	B	509
20	885	324T	36	18	14.4	64	32	25.6	290	145	116	G	90	90.8	91	46	58	65	119	140	200	15	35	B	636
25	3525	284TS	14	7	5.6	58	29	23.2	366	183	146.4	G	91.4	92.2	91.7	81	86	88	37	160	250	16	30	B	526
25	1775	284T	22	11	8.8	60	30	24	366	183	146.4	G	93.5	94	93.6	71	80	84	74	180	250	24	44	B	460
25	1185	324T	28	14	11.2	66	33	26.4	366	183	146.4	G	92.7	93.2	93	62	72	76	111-	170	240	28	54	B	805
25	885	326T	44	22	17.6	80	40	32	366	183	146.4	G	90.4	91.2	91	48	59	65	149	150	200	22	40	B	683

Explosion Proof Low Voltage NEMA Motors – 60Hz | XP100/XP100 IDI | NEMA Premium

HP	FL RPM	Frame	Current (A)									KVA/ HP Code	Nominal Efficiency (%)			Power Factor			Torque			Locked Rotor Stall Time		NEMA Design	Approx. Weight (LBS)
			No Load			Full Load			Locked Rotor				1/2 Load (%)	3/4 Load (%)	Full Load (%)	1/2 Load (%)	3/4 Load (%)	Full Load (%)	Full Load Lb-FT	Locked Rotor TA/TN (%)	Break Down Tk/TN (%)	Hot (sec)	Cold (sec)		
			230V	460V	575V	230V	460V	575V	230V	460V	575V														
30	3530	286TS	17	8.5	6.8	68	34	27.2	436	218	174.4	G	91.4	92.2	91.7	84	89	90	45	160	250	16	30	B	521
30	1775	286T	24	12	9.6	70	35	28	454	227	181.6	G	93.9	94.1	93.6	73	82	85	89	180	250	24	44	B	493
30	1185	326T	30	15	12	78	39	31.2	436	218	174.4	G	93.1	93.5	93	61	73	77	133	170	220	26	52	B	685
30	885	364T	36	18	14.4	82	41	32.8	420	210	168	G	90.6	92	91.7	49	61	65	178	150	200	22	40	B	860
40	3535	324TS	24	12	9.6	90	45	36	580	290	232	G	94	94.1	93.6	80	87	89	60	150	250	22	45	B	610
40	1780	324T	30	15	12	92	46	36.8	580	290	232	G	94.3	94.1	94.1	75	83	86	118	180	230	22	45	B	653
40	1185	364T	38	19	15.2	98	49	39.2	580	290	232	G	94.4	94.6	94.1	68	77	81	177	190	220	29	55	B	606
40	885	365T	72	36	28.8	126	63	50.4	580	290	232	G	93	93.1	91.7	49	60	65	237	150	200	25	40	B	940
50	3535	326TS	30	15	12	110	55	44	726	363	290.4	G	93.8	94.1	93.6	82	89	91	74	150	250	18	37	B	600
50	1780	326T	38	19	15.2	116	58	46.4	768	384	307.2	G	94.8	95	94.5	74	82	85	148	170	230	22	45	B	695
50	1185	365T	48	24	19.2	124	62	49.6	726	363	290.4	G	94	94.3	94.1	67	76	80	222	190	220	29	55	B	850
50	885	404T	56	28	22.4	134	67	53.6	726	363	290.4	G	93	93.1	92.4	64	73	76	297	140	200	25	40	B	1050
60	3565	364TS	38	19	15.2	136	68	54.4	870	435	348	G	93.8	94.1	93.6	80	86	88	89	160	250	16	28	B	790
60	1780	364T	42	21	16.8	136	68	54.4	870	435	348	G	95.2	95.4	95	77	85	87	177	180	240	26	38	B	890
60	1185	404T	56	28	22.4	148	74	59.2	870	435	348	G	94.2	94.7	94.5	65	76	80	266	180	220	25	50	B	1055
60	885	405T	60	30	24	156	78	62.4	870	435	348	G	93	93.1	92.4	66	75	78	356	140	200	30	35	B	1050
75	3565	365TS	44	22	17.6	172	86	68.8	1086	543	434.4	G	93.7	94.3	94.1	81	86	88	111-	160	260	16	27	B	945
75	1780	365T	50	25	20	170	85	68	1086	543	434.4	G	95.6	95.8	95.4	78	85	87	221	180	240	25	35	B	947
75	1185	405T	68	34	27.2	186	93	74.4	1086	543	434.4	G	94.7	94.9	94.5	68	77	80	332	180	220	33	45	B	1025
75	885	444T	74	37	29.6	188	94	75.2	1086	543	434.4	G	93.5	93.9	93.6	67	76	80	445	135	200	25	32	B	1551
100	3570	405TS	38	19	15.2	216	108	86.4	1450	725	580	G	94.6	94.7	94.1	90	92	92	147	120	200	25	45	B	1020
100	1780	405T	60	30	24	226	113	90.4	1450	725	580	G	95.8	96	95.4	80	86	87	295	180	200	25	35	B	1189
100	1185	444T	78	39	31.2	234	117	93.6	1450	725	580	G	95.1	95.3	95	73	81	84	443	160	200	30	35	B	1551
100	885	445T	96	48	38.4	246	123	98.4	1450	725	580	G	94.2	94.5	94.1	70	78	81	593	130	200	22	30	B	1770
125	3575	444TS	64	32	25.6	276	138	110.4	1816	908	726.4	G	94.5	95.1	95	84	88	89	184	120	200	18	23	B	1450
125	1785	444T	90	45	36	286	143	114.4	1816	908	726.4	G	95.4	95.6	95.4	78	84	86	368	160	200	20	25	B	1659

HP	FL RPM	Frame	Current (A)									KVA/ HP Code	Nominal Efficiency (%)			Power Factor			Torque			Locked Rotor Stall Time		NEMA Design	Approx. Weight (LBS)
			No Load			Full Load			Locked Rotor				1/2 Load (%)	3/4 Load (%)	Full Load (%)	1/2 Load (%)	3/4 Load (%)	Full Load (%)	Full Load Lb-FT	Locked Rotor TA/TN (%)	Break Down Tk/TN (%)	Hot (sec)	Cold (sec)		
			230V	460V	575V	230V	460V	575V	230V	460V	575V														
125	1185	445T	96	48	38.4	288	144	115.2	1816	908	726.4	G	95.1	95.4	95	74	82	85	554	160	200	25	35	B	1771
125	885	447T	108	54	43.2	304	152	121.6	1816	908	726.4	G	94.6	94.7	94.1	70	79	82	742	130	200	20	30	B	2029
150	3575	445TS	74	37	29.6	328	164	131.2	2170	1085	868	G	94.8	95.2	95	84	89	90	220	120	200	15	18	B	1611
150	1785	445T	104	52	41.6	340	170	136	2170	1085	868	G	95.7	96	95.8	78	84	86	441	150	200	20	30	B	1934
150	1190	447T	118	59	47.2	344	172	137.6	2170	1085	868	G	95.6	96	95.8	73	82	85	662	140	200	28	43	B	2051
150	885	449T	122	61	48.8	360	180	144	2170	1085	868	G	94.3	94.5	94.1	72	80	83	890	130	200	20	25	B	2508
200	3575	445TS	88	44	35.2	432	216	172.8	2900	1450	1160	G	95.3	95.6	95.4	88	90	91	294	120	200	16	20	B	2250
200	1785	445T	146	73	58.4	456	228	182.4	2900	1450	1160	G	96.2	96.5	96.2	75	83	85	588	160	200	18	25	B	2503
200	1190	447T	146	73	58.4	454	227	181.6	2900	1450	1160	G	95.6	96.2	95.8	75	83	86	883	125	200	25	32	B	2450
200	885	S449LS	156	78	62.4	480	240	192	2900	1450	1160	G	95	95	94.5	71	79	83	1187	125	200	15	25	B	2450
250	3575	449TS	90	45	36	530	265	212	3650	1825	1460	G	95.7	96	95.8	89	91	91	368	120	200	12	18	B	2300
250	1785	449T	180	90	72	556	278	222.4	4200	2100	1680	H	96.1	96.3	96.2	78	85	87	735	140	200	18	25	A	2490
250	1190	449T	172	86	68.8	562	281	224.8	4100	2050	1640	H	95.7	96	95.8	81	86	87	1104	120	200	20	25	A	2498
300	3570	449TS	136	68	54.4	650	325	260	4400	2200	1760	G	95.2	95.8	95.8	86	90	91	441	100	200	12	13	B	2300
300	1785	449T	228	114	91.2	676	338	270.4	4800	2400	1920	H	96.1	96.3	96.2	75	83	86	882	140	200	22	30	A	2350

4.3.2.4. LP100, HP100

Definite Purpose Low Voltage NEMA Motors – 60Hz | LP100 | NEMA Premium | Solid Shaft Vertical Motors

HP	FL RPM	Frame	Current (A)									KVA/ HP Code	Nominal Efficiency (%)			Power Factor			Torque			Locked Rotor Stall Time		NEMA Design	Approx. Weight (LBS)
			No Load			Full Load			Locked Rotor				1/2 Load (%)	3/4 Load (%)	Full Load (%)	1/2 Load (%)	3/4 Load (%)	Full Load (%)	Full Load Lb-FT	Locked Rotor TA/TN (%)	Break Down Tk/TN (%)	Hot (sec)	Cold (sec)		
			230V	460V	575V	230V	460V	575V	230V	460V	575V														
3	3520	182LP	3.4	1.7	1.36	7.6	3.8	3.04	60	30	24	J	84.17	86.3	86.5	69.5	79.8	85.5	4.4	185	380	20	30	B	118
3	1760	182LP	4.2	2.1	1.68	8	4	3.2	66	33	26.4	K	87.8	89.4	89.5	59.5	71.7	78.5	9	235	360	17	29	B	129
3	1175	213LP	5	2.5	2	8.6	4.3	3.44	64	32	25.6	K	87.8	89.3	89.5	52.1	65.4	73	13.4	265	470	23	35	B	192
5	3505	184LP	4	2	1.6	12	6	4.8	92	46	36.8	J	88.2	89.1	88.5	78.1	85.9	88.2	7.5	170	420	15	29	B	130
5	1755	184LP	6	3	2.4	13	6.5	5.2	92	46	36.8	J	89.2	90	89.5	63.6	75.1	80.5	15	220	350	14	29	B	135
5	1165	215LP	7	3.5	3.6	13.4	6.7	5.36	92	46	36.8	J	89.5	90.1	89.5	59.4	71.4	78.1	26.5	220	380	14	21	B	204
7.5	3520	213LP	6	3	2.4	17.6	8.8	7.04	126	63	50.4	H	89.6	90.1	89.5	78.5	86.8	89.2	11	180	490	17	30	B	188
7.5	1765	213LP	10	5	4	19.4	9.7	7.76	126	63	50.4	H	90.73	91.7	91.7	60.5	72.3	78.9	22	270	450	25	42	B	212
7.5	1175	254LP	10	5	4	20	10	8	126	63	50.4	H	91.1	91.5	91	58.4	70.2	77.2	33	165	260	26	45	B	294
10	3515	215LP	7	3.5	2.8	23	11.5	9.2	162	81	64.8	H	91	91.1	90.2	81.5	88.8	90.3	15	180	440	14	28	B	202
10	1755	215LP	12.2	6.1	4.88	25	12.5	10	162	81	64.8	H	91.7	92.2	91.7	63.8	76.2	81.7	30	270	410	20	36	B	220
10	1175	256LP	12.6	6.3	5.04	27	13.5	10.8	162	81	64.8	H	91.4	91.6	91	61	71.6	76.2	45	165	250	18	38	B	310
15	3530	254LP	10.2	5.1	4.08	35	17.5	14	232	116	92.8	G	90.7	91.3	91	80.6	87.4	88.2	22	210	260	24	48	B	309
15	1770	254LP	17	8.5	6.8	38	19	15.2	232	116	92.8	G	92.3	92.8	92.4	64.5	74.7	80	44	185	235	21	33	B	315
15	1180	284LPH	22	11	8.8	42	21	16.8	232	116	92.8	G	90.9	91.8	91.7	53	66	73	67	150	240	22	48	B	601
20	3515	256LP	10.4	5.2	4.16	45	22.5	18	290	145	116	G	92.1	91.6	91	86.2	91.3	91.5	30	185	230	20	45	B	337
20	1770	256LP	21	10.5	8.4	50	25	20	290	145	116	G	93.1	93.4	93	65.3	75.9	80.5	60	185	240	15	33	B	342

HP	FL RPM	Frame	Current (A)									KVA/ HP Code	Nominal Efficiency (%)			Power Factor			Torque		Locked Rotor Stall Time		NEMA Design	Approx. Weight (LBS)	
			No Load			Full Load			Locked Rotor				1/2 Load (%)	3/4 Load (%)	Full Load (%)	1/2 Load (%)	3/4 Load (%)	Full Load (%)	Full Load Lb-FT	Locked Rotor TA/TN (%)	Break Down Tk/TN (%)	Hot (sec)			Cold (sec)
			230V	460V	575V	230V	460V	575V	230V	460V	575V														
20	1180	286LPH	26	13	10.4	54	27	21.6	290	145	116	G	91.2	92	91.7	57	69	76	89	150	240	20	45	B	656
25	3525	284LPH	16	8	6.4	58	29	23.2	366	183	146.4	G	92	92.2	91.7	80	85	88	37	160	250	16	30	B	559
25	1775	284LPH	22	11	8.8	60	30	24	366	183	146.4	G	93.5	94	93.6	71	80	84	74	180	250	24	44	B	640
25	1185	324LP	28	14	11.2	66	33	26.4	366	183	146.4	G	92.7	93.2	93	62	72	76	111-	170	240	28	54	B	884
30	3525	286LPH	19	9.5	7.6	68	34	27.2	436	218	174.4	G	92	92.2	91.7	84	89	90	45	160	250	16	30	B	591
30	1775	286LPH	24	12	9.6	70	35	28	436	218	174.4	G	93.9	94.1	93.6	73	82	85	89	180	250	24	44	B	649
30	1185	326LP	30	15	12	78	39	31.2	436	218	174.4	G	93.1	93.5	93	64	73	77	133	170	220	26	52	B	920
40	3535	324LP	24	12	9.6	90	45	36	580	290	232	G	94	94.1	93.6	80	87	89	60	150	250	22	45	B	784
40	1780	324LP	30	15	12	92	46	36.8	580	290	232	G	94.3	94.1	94.1	75	83	86	118	180	230	22	45	B	848
40	1185	364LP	36	18	14.4	98	49	39.2	580	290	232	G	94.4	94.1	94.1	70	79	81	177	190	220	29	55	B	822

Definite Purpose Low Voltage NEMA Motors – 60Hz | LP100 | NEMA Premium | Solid Shaft Vertical Motors

HP	FL RPM	Frame	Current (A)									KVA/ HP Code	Nominal Efficiency (%)			Power Factor			Torque		Locked Rotor Stall Time		NEMA Design	Approx. Weight (LBS)	
			No Load			Full Load			Locked Rotor				1/2 Load (%)	3/4 Load (%)	Full Load (%)	1/2 Load (%)	3/4 Load (%)	Full Load (%)	Full Load Lb-FT	Locked Rotor TA/TN (%)	Break Down Tk/TN (%)	Hot (sec)			Cold (sec)
			230V	460V	575V	230V	460V	575V	230V	460V	575V														
50	3535	326LP	30	15	12	110	55	44	726	363	290.4	G	93.8	94.1	93.6	82	89	91	74	150	250	18	37	B	799
50	1780	326LP	38	19	15.2	116	58	46.4	726	363	290.4	G	94.8	95	94.5	74	82	85	148	170	230	22	45	B	957

HP	FL RPM	Frame	Current (A)									KVA/ HP Code	Nominal Efficiency (%)			Power Factor			Torque			Locked Rotor Stall Time		NEMA Design	Approx. Weight (LBS)
			No Load			Full Load			Locked Rotor				1/2 Load (%)	3/4 Load (%)	Full Load (%)	1/2 Load (%)	3/4 Load (%)	Full Load (%)	Full Load Lb-FT	Locked Rotor TA/TN (%)	Break Down Tk/TN (%)	Hot (sec)	Cold (sec)		
			230V	460V	575V	230V	460V	575V	230V	460V	575V														
50	1185	365LP	48	24	19.2	124	62	49.6	726	363	290.4	G	94	94.3	94.1	67	76	80	222	190	220	29	55	B	855
60	3565	364LP	38	19	15.2	136	68	54.4	870	435	348	G	93.8	94.1	93.6	80	86	88	89	160	250	16	28	B	836
60	1780	364LP	38	19	15.2	136	68	54.4	870	435	348	G	95.2	95.4	95	77	85	87	177	180	240	26	38	B	885
60	1185	404LP	56	28	22.4	148	74	59.2	870	435	348	G	94.2	94.7	94.5	65	76	80	266	180	220	25	50	B	1021
75	3565	365LP	44	22	17.6	172	86	68.8	1086	543	434.4	G	93.7	94.3	94.1	81	86	88	111-	160	260	16	27	B	877
75	1780	365LP	50	25	20	170	85	68	1086	543	434.4	G	95.6	95.8	95.4	78	85	87	221	180	240	25	35	B	948
75	1185	405LP	68	34	27.2	186	93	74.4	1086	543	434.4	G	94.7	94.9	94.5	68	77	80	332	180	220	33	45	B	1088
100	3570	405LP	38	19	15.2	216	108	86.4	1450	725	580	G	94.6	94.7	94.1	90	92	92	147	120	200	25	45	B	1057
100	1780	405LP	60	30	24	226	113	90.4	1450	725	580	G	95.8	96	95.4	80	86	87	295	180	200	25	35	B	1059
100	1185	444LP	78	39	31.2	234	117	93.6	1450	725	580	G	95.1	95.3	95	73	81	84	443	160	200	30	35	B	1385
125	1785	444LP	90	45	36	286	143	114.4	1816	908	726.4	G	95.4	95.6	95.4	78	84	86	368	160	200	20	25	B	1429
125	1185	445LP	96	48	38.4	288	144	115.2	1816	908	726.4	G	95.1	95.4	95	74	82	85	554	160	200	25	35	B	1565
150	1785	445LP	104	52	41.6	340	170	136	2170	1085	868	G	95.7	96	95.8	78	84	86	441	150	200	20	30	B	1565
150	1190	447LP	118	59	47.2	344	172	137.6	2170	1085	868	G	95.6	96	95.8	73	82	85	662	140	200	28	43	B	1778
200	1785	447LP	140	70	56	452	226	180.8	2900	1450	1160	G	96.2	96.5	96.2	76	84	86	588	160	200	18	25	B	1843
200	1190	449LP	146	73	58.4	454	227	181.6	2900	1450	1160	G	95.6	96.2	95.8	75	83	86	883	125	200	25	32	B	2204
250	1785	449LP	180	90	72	556	278	222.4	4200	2100	1680	H	96.1	96.3	96.2	78	85	87	735	140	200	18	25	A	2203
250	1190	449LP	172	86	68.8	562	281	224.8	4100	2050	1640	H	95.7	96	95.8	81	86	87	1104	120	200	20	25	A	2191

Definite Purpose Low Voltage NEMA Motors – 60Hz | HP100 | NEMA Premium | Vertical Solid Shaft Motors

HP	FL RPM	Frame	Current (A)									KVA/ HP Code	Nominal Efficiency (%)			Power Factor			Torque			Locked Rotor Stall Time		NEMA Design	Approx. Weight (LBS)
			No Load			Full Load			Locked Rotor				1/2 Load (%)	3/4 Load (%)	Full Load (%)	1/2 Load (%)	3/4 Load (%)	Full Load (%)	Full Load Lb-FT	Locked Rotor TA/TN (%)	Break Down Tk/TN (%)	Hot (sec)	Cold (sec)		
			230V	460V	575V	230V	460V	575V	230V	460V	575V														
3	3520	182HP	3.4	1.7	1.36	7.6	3.8	3.04	60	30	24	J	84.17	86.3	86.5	69.5	79.8	85.5	4.4	185	380	20	30	B	118
3	1760	182HP	4.2	2.1	1.68	8	4	3.2	66	33	26.4	K	87.8	89.4	89.5	59.5	71.7	78.5	9	235	360	17	29	B	129
3	1175	213HP	5	2.5	2	8.6	4.3	3.44	64	32	25.6	K	87.8	89.3	89.5	52.1	65.4	73	13.4	265	470	23	35	B	192
5	3505	184HP	4	2	1.6	12	6	4.8	92	46	36.8	J	88.2	89.1	88.5	78.1	85.9	88.2	7.5	170	420	15	29	B	130
5	1755	184HP	6	3	2.4	13	6.5	5.2	92	46	36.8	J	89.2	90	89.5	63.6	75.1	80.5	15	220	350	14	29	B	135
5	1165	215HP	7	3.5	3.6	13.4	6.7	5.36	92	46	36.8	J	89.5	90.1	89.5	59.4	71.4	78.1	26.5	220	380	14	21	B	204
7.5	3520	213HP	6	3	2.4	17.6	8.8	7.04	126	63	50.4	H	89.6	90.1	89.5	78.5	86.8	89.2	11	180	490	17	30	B	188
7.5	1765	213HP	10	5	4	19.4	9.7	7.76	126	63	50.4	H	90.73	91.7	91.7	60.5	72.3	78.9	22	270	450	25	42	B	211
7.5	1175	254HP	10	5	4	20	10	8	126	63	50.4	H	91.1	91.5	91	58.4	70.2	77.2	33	165	260	26	45	B	294
10	3515	215HP	7	3.5	2.8	23	11.5	9.2	162	81	64.8	H	91	91.1	90.2	81.5	88.8	90.3	15	180	440	14	28	B	202
10	1755	215HP	12.2	6.1	4.88	25	12.5	10	162	81	64.8	H	91.7	92.2	91.7	63.8	76.2	81.7	30	270	410	20	36	B	220
10	1175	256HP	12.6	6.3	5.04	27	13.5	10.8	162	81	64.8	H	91.4	91.6	91	61	71.6	76.2	45	165	250	18	38	B	310
15	3530	254HP	10.2	5.1	4.08	35	17.5	14	232	116	92.8	G	90.7	91.3	91	80.6	87.4	88.2	22	210	260	24	48	B	309
15	1770	254HP	17	8.5	6.8	38	19	15.2	232	116	92.8	G	92.3	92.8	92.4	64.5	74.7	80	44	185	235	21	33	B	315
15	1180	284HP	22	11	8.8	42	21	16.8	232	116	92.8	G	90.9	91.8	91.7	53	66	73	67	150	240	22	48	B	494
20	3515	256HP	10.4	5.2	4.16	45	22.5	18	290	145	116	G	92.1	91.6	91	86.2	91.3	91.5	30	185	230	20	45	B	337
20	1770	256HP	21	10.5	8.4	50	25	20	290	145	116	G	93.1	93.4	93	65.3	75.9	80.5	60	185	240	15	33	B	342
20	1180	286HP	26	13	10.4	54	27	21.6	290	145	116	G	91.2	92	91.7	57	69	76	89	150	240	20	45	B	551
25	3525	284HP	16	8	6.4	58	29	23.2	366	183	146.4	G	92	92.2	91.7	80	85	88	37	160	250	16	30	B	454

HP	FL RPM	Frame	Current (A)									KVA/ HP Code	Nominal Efficiency (%)			Power Factor			Torque			Locked Rotor Stall Time		NEMA Design	Approx. Weight (LBS)
			No Load			Full Load			Locked Rotor				1/2 Load (%)	3/4 Load (%)	Full Load (%)	1/2 Load (%)	3/4 Load (%)	Full Load (%)	Full Load Lb-FT	Locked Rotor TA/TN (%)	Break Down Tk/TN (%)	Hot (sec)	Cold (sec)		
			230V	460V	575V	230V	460V	575V	230V	460V	575V														
25	1775	284HP	22	11	8.8	60	30	24	366	183	146.4	G	93.5	94	93.6	71	80	84	74	180	250	24	44	B	535
25	1185	324HP	28	14	11.2	66	33	26.4	366	183	146.4	G	92.7	93.2	93	62	72	76	111-	170	240	28	54	B	773
30	3525	286HP	19	9.5	7.6	68	34	27.2	436	218	174.4	G	92	92.2	91.7	84	89	90	45	160	250	16	30	B	486
30	1775	286HP	24	12	9.6	70	35	28	436	218	174.4	G	93.9	94.1	93.6	73	82	85	89	180	250	24	44	B	544
30	1185	326HP	30	15	12	78	39	31.2	436	218	174.4	G	93.1	93.5	93	64	73	77	133	170	220	26	52	B	809
40	3535	324HP	24	12	9.6	90	45	36	580	290	232	G	94	94.1	93.6	80	87	89	60	150	250	22	45	B	674
40	1780	324HP	30	15	12	92	46	36.8	580	290	232	G	94.3	94.1	94.1	75	83	86	118	180	230	22	45	B	737
40	1185	364HP	36	18	14.4	98	49	39.2	580	290	232	G	94.4	94.1	94.1	70	79	81	177	190	220	29	55	B	802

Definite Purpose Low Voltage NEMA Motors – 60Hz | HP100 | NEMA Premium | Vertical Solid Shaft Motors

HP	FL RPM	Frame	Current (A)									KVA/ HP Code	Nominal Efficiency (%)			Power Factor			Torque			Locked Rotor Stall Time		NEMA Design	Approx. Weight (LBS)
			No Load			Full Load			Locked Rotor				1/2 Load (%)	3/4 Load (%)	Full Load (%)	1/2 Load (%)	3/4 Load (%)	Full Load (%)	Full Load Lb-FT	Locked Rotor TA/TN (%)	Break Down Tk/TN (%)	Hot (sec)	Cold (sec)		
			230V	460V	575V	230V	460V	575V	230V	460V	575V														
50	3535	326HP	30	15	12	110	55	44	726	363	290.4	G	93.8	94.1	93.6	82	89	91	74	150	250	18	37	B	689
50	1780	326HP	38	19	15.2	116	58	46.4	726	363	290.4	G	94.8	95	94.5	74	82	85	148	170	230	22	45	B	846
50	1185	365HP	48	24	19.2	124	62	49.6	726	363	290.4	G	94	94.3	94.1	67	76	80	222	190	220	29	55	B	835

HP	FL RPM	Frame	Current (A)									KVA/ HP Code	Nominal Efficiency (%)			Power Factor			Torque			Locked Rotor Stall Time		NEMA Design	Approx. Weight (LBS)
			No Load			Full Load			Locked Rotor				1/2 Load (%)	3/4 Load (%)	Full Load (%)	1/2 Load (%)	3/4 Load (%)	Full Load (%)	Full Load Lb-FT	Locked Rotor TA/TN (%)	Break Down Tk/TN (%)	Hot (sec)	Cold (sec)		
			230V	460V	575V	230V	460V	575V	230V	460V	575V														
60	3565	364HP	38	19	15.2	136	68	54.4	870	435	348	G	93.8	94.1	93.6	80	86	88	89	160	250	16	28	B	817
60	1780	364HP	38	19	15.2	136	68	54.4	870	435	348	G	95.2	95.4	95	77	85	87	177	180	240	26	38	B	865
60	1185	404HP	56	28	22.4	148	74	59.2	870	435	348	G	94.2	94.7	94.5	65	76	80	266	180	220	25	50	B	1000
75	3565	365HP	44	22	17.6	172	86	68.8	1086	543	434.4	G	93.7	94.3	94.1	81	86	88	111	160	260	16	27	B	857
75	1780	365HP	50	25	20	170	85	68	1086	543	434.4	G	95.6	95.8	95.4	78	85	87	221	180	240	25	35	B	928
75	1185	405HP	68	34	27.2	186	93	74.4	1086	543	434.4	G	94.7	94.9	94.5	68	77	80	332	180	220	33	45	B	1068
100	3570	405HP	38	19	15.2	216	108	86.4	1450	725	580	G	94.6	94.7	94.1	90	92	92	147	120	200	25	45	B	1023
100	1780	405HP	60	30	24	226	113	90.4	1450	725	580	G	95.8	96	95.4	80	86	87	295	180	200	25	35	B	1073
100	1185	444HP	78	39	31.2	234	117	93.6	1450	725	580	G	95.1	95.3	95	73	81	84	443	160	200	30	35	B	1372
125	1785	444HP	90	45	36	286	143	114.4	1816	908	726.4	G	95.4	95.6	95.4	78	84	86	368	160	200	20	25	B	1419
125	1185	445HP	96	48	38.4	288	144	115.2	1816	908	726.4	G	95.1	95.4	95	74	82	85	554	160	200	25	35	B	1557
150	1785	445HP	104	52	41.6	340	170	136	2170	1085	868	G	95.7	96	95.8	78	84	86	441	150	200	20	30	B	1559
150	1190	447HP	118	59	47.2	344	172	137.6	2170	1085	868	G	95.6	96	95.8	73	82	85	662	140	200	28	43	B	1786
200	1785	447HP	140	70	56	452	226	180.8	2900	1450	1160	G	96.2	96.5	96.2	76	84	86	588	160	200	18	25	B	1854
200	1190	449HP	146	73	58.4	454	227	181.6	2900	1450	1160	G	95.6	96.2	95.8	75	83	86	883	125	200	25	32	B	2216
250	1785	449HP	180	90	72	556	278	222.4	4200	2100	1680	H	96.1	96.3	96.2	78	85	87	735	140	200	18	25	A	2246
250	1190	449HP	172	86	68.8	562	281	224.8	4100	2050	1640	H	95.7	96	95.8	81	86	87	1104	120	200	20	25	A	2203

4.3.2.5. SD10 MS

Definite Purpose Low Voltage NEMA Motors | SD10 MS | Energy Efficient | Multi Speed Motors

HP	FL RPM	Frame	Current (A)			KVA/ HP Code	Nominal Efficiency (%)			Power Factor			Torque			Locked Rotor Stall Time	
			No Load	Full Load	Locked Rotor		1/2 Load (%)	3/4 Load (%)	Full Load (%)	1/2 Load (%)	3/4 Load (%)	Full Load (%)	Full Load Lb-FT	Locked Rotor TA/TN (%)	Break Down Tk/TN (%)	Hot (sec)	Cold (sec)
			460V	460V	460V												
1/0.25	1763/876	143T	1.1/0.7	1.6/0.8	15.6/3.8	K	70.0/48.2	79.0/57.4	81.0/64.5	49/33	62/41	71/48	2.9/1.5	420/340	480/380	30	40
1.5/0.37	1755/870	145T	1.5/0.9	2.3/1.1	20.9/5.2	K	76/53	80/61	81.3/65.5	52/33	66/42	73/49	4.5/2.4	390/340	430/360	30	40
2/0.5	1775/880	182T	2.2/1.3	3.4/1.5	25.0/10.0	K	84.5/68.0	86.0/72.0	86.5/74.0	55/48	68/62	75/69	5.9/3.0	230/150	260/210	30	40
3/0.75	1765/875	184T	2.6/1.5	4.4/1.9	32.0/12.5	J	85.7/71.7	87.7/76.7	87.5/78.5	54/46	67/60	75/68	8.9/4.5	240/150	280/200	30	40
5/1.2	1760/865	213T	5.0/2.4	7.7/3.0	47.0/9.5	J	83.4/58.5	85.1/65.1	86.5/75.5	50/30	62.3/39.0	72/50	14.9/7.2	230/130	330/200	30	40
7.5/1.9	1755/875	215T	4.1/2.6	9.6/3.7	63.5/13.8	J	88.1/71	88.9/74.4	87.5/78.5	61/38	76.0/50.2	83/56	22.7/11.2	210/130	380/330	30	40
10/2.5	1765/880	254T	5.1/3.5	12.5/4.8	67.9/16.5	H	89.7/72.7	89.4/76.9	90.4/85.8	64/39	79.9/51.8	84/56	29.6/14.9	180/150	260/210	30	40
15/3.7	1765/880	256T	6.9/4.5	18.0/7.0	116.0/64.0	J	88.3/79.0	90.4/84.5	90.2/86.5	50/40	65/50	83/56	44.0/22.0	180/160	200/180	30	60
20/5	1770/880	284T	10/7.2	25/9.3	153/37	G	88.7/80	89/83	88.5/84	71/38	51/50	85/59	59.4/30	190/180	270/250	19	40
25/6.2	1765/880	286T	10.5/8	30/11.5	177/46	G	90.3/82.9	90.4/85.2	89.5/85.5	76/40	84/52	87/60	74/37	190/150	240/200	19	40
30/7.5	1770/885	324T	11.5/8.5	35/13	240/554	H	91.9/85	92.3/87.7	91.7/88.5	85/44	77/56	88/61	89/45	220/150	270/200	20	40
40/10	1770/885	326T	16/11.2	46/17	340/81	H	92.7/85.8	92.9/88.4	92.4/88.5	73/41	83/53	88/61	124/59	200/150	260/220	20	40
50/12.5	1780/890	364T	20.5/15.5	58/22.5	425/97	H	93.3/86.4	93.5/88.8	93/89.5	73/38	83/50	86/58	147/74	180/130	240/200	22	42
60/15	1780/885	365T	26/18.5	93.3/86.2	458/103	G	93.3/86.2	93.5/81	93/88.5	73/39	81/51	85/59	178/89	160/125	240/200	22	45
75/19	1785/890	405T	26.5/20	86/32	568/120	G	90.5/85.8	92.6/88.1	93/88.5	79/45	84/56	86/63	220/112	160/140	250/190	23	42
100/25	1790/890	444TS	41.5/31	118/46	804/178	H	94/88.4	94.1/90.4	93.6/91	73/40	81/51	84/59	293/147	220/150	280/200	28	36
125/31	1790/890	445TS	46/39	158/57	1045/223	H	92.7/88.9	93.2/90.9	93/91.7	67/38	77/48	81/56	367/182	190/150	240/200	20	23
150/37.5	1785/890	447TS	64.5/45.5	176/68	1260/273	H	92.1/87.6	93.2/89.6	93.6/90.2	73/39	82/50	85/58	441/221	210/170	270/200	24	29

4.4. Additional technical tables

4.4.1. Paint System Chart

Paint Systems for Low Voltage NEMA Motors

	Standard ABB Paint System		Special Paint Systems Offered by ABB				
	Standard Alkyd + Epoxy	2 Part Epoxy (N01)	3 Part Epoxy (N02)	Prime Only (N03)	3 Part Epoxy Paint (Coastal-Offshore High Salt) (N05)	2 Part Epoxy Paint C4 (N06)	2 Part Epoxy Paint C5-I/ C5-M (N07)
Priming of internal and external surfaces							
Type	Modified Alkyd or Epoxy polyamide	Primetal EB	Zinc Inorganic	Modified Alkyd or Epoxy polyamide	Zinc Inorganic	Zinc Inorganic	Zinc Inorganic
Color	Red/ Grey	Red Iron Oxide	Metallic Gray	Red/ Grey	Metallic Gray	Metallic Gray	Metallic Gray
Sheen	Flat	Flat	Flat	Flat	Flat	Flat	Flat
Dry film thickness	2.0 – 3.0 mils.	8.0 - 12.0 mils	3.0 - 5.0 mils	1.5 - 2.0 mils	3.0 - 5.0 mils	5.0 -6.0 mils	5.0 -6.0 mils
Intermediate coat of external surfaces							
Type	–	–	Epoxy	–	Epoxy	–	–
Color	–	–	White	–	White	–	–
Sheen	–	–	Flat	–	Flat	–	–
Dry film thickness	–	–	5.0 – 6.0 mils	–	5.0 – 6.0 mils	–	–
Top coat on external surfaces							
Type	Modified NC Alkyd or Epoxy	Prometal APU	Modified polyurethane	–	Modified polyurethane	EPX-80 (Epoxy)	EPX-80 (Epoxy)
Color	Dark Charcoal Gray	Dark Charcoal Gray	Dark Charcoal Gray	–	Dark Charcoal Gray	Dark Charcoal Gray	Dark Charcoal Gray
Sheen	Flat	Semi-Gloss	Gloss	–	Gloss	Gloss	Gloss
Dry film thickness	3.0 – 6.0 mils.	3.0 - 4.0 mils	3.0 - 4.0 mils	–	5.0 – 6.0 mils	7.0 – 9.0 mils	8.0 – 11.0 mils
Total film thickness	5.0 – 9.0 mils	11.0 - 16.0 mils	11.0 - 15.0 mils	1.5 - 2.0 mils	13.0 – 17.0 mils	12.0 – 15.0 mils	13.0 –17.0 mils
Salt Spray resistance (hours)	400	1500	2000	–	2000+	2000	2000+
Corrosivity Category	C2	C3	C4	–	C5I & C5M	C4	C5I & C5M

4.4.2. Balance Table

Balance	NEMA	Precision Balance (M69)		Extra Precision Balance (M70)		
Frames	140-449	140-320	360-449	140-256	280-320	360-449
RPM						
Maximum amplitude, inches, peak to peak (mils P/P)						
0 - 999	2.5	0.5	0.75	0.2	0.3	0.4
1000 - 1999	2.0	0.5	0.75	0.2	0.3	0.4
2000 - 2999	1.5	0.5	0.75	0.2	0.3	0.4
3000 - 4000	1.0	0.5	0.75	0.2	0.3	0.4
Velocity, inches, inches/seconds (in/sec)						
0 - 999	0.1308	0.0262	0.0392	0.105	0.0157	0.0209
1000 - 1999	0.2093	0.0523	0.0785	0.0209	0.0314	0.0419
2000 - 2999	0.2355	0.0785	0.1178	0.0314	0.0471	0.0628
3000 - 4000	0.2094	0.1047	0.1571	0.0419	0.0628	0.0838

5. Drawings and Dimensions

General motor drawings, dimensions of accessories, general packing weights and dimensions

- 5.1. Drawings and Dimensions224**
 - 5.1.1. Next Generation – Schematics225
 - 5.1.1.1. SD200, SD200 841 – 444 – L449 Frame.....225
 - 5.1.1.2. SD200, DP200 HPS – 500 Frame.....228
 - 5.1.2. Low Voltage NEMA Motors – Schematics230
 - 5.1.2.1. GP100A, GP100 – 140-320 Frame230
 - 5.1.2.2. GP100 – 360 - 440 Frame.....233
 - 5.1.2.3. SD100 – 140 – 320 Frame.....236
 - 5.1.2.4. SD100 – 360 – S440 Frame.....239
 - 5.1.2.5. SD100 IEEE, SD661 – 140 – 320 Frame242
 - 5.1.2.6. SD100 IEEE, SD661 – 360 – S440 Frame.....245
 - 5.1.2.7. XP100, XP100 ID1– 140 – 320 Frame 248
 - 5.1.2.8. XP100, XP100 ID1 – 360 – 440 Frame 251
 - 5.1.2.9. 140-320 Frame Foot Mount.....254
 - 5.1.2.10. SD10 MS – 360 – 440 Frame.....257
 - 5.1.2.11. HP100, LP100 – 180 – 440 Frame 260
 - 5.1.3. Terminal Boxes – Schematics262
 - 5.1.3.1. SD200, SD200 841, DP200 HPS.....262
 - 5.1.3.2. GP100A, GP100.....264
 - 5.1.3.3. SD100, SD100 IEEE, SD10 MS, HP100, LP100.....266
 - 5.1.3.4. XP100, XP100 ID1.....267
 - 5.1.3.5. Auxiliary Boxes.....268
 - 5.1.3.6. Special Oversized Boxes269
- 5.2. Dimensions of Accessories.....273**
 - 5.2.1. Blower Dimensions273
 - 5.2.2. Brake Dimensions/Data275
 - 5.2.3. Encoder Dimensions.....277
 - 5.2.4. Drip Cover and NDE Shaft278
- 5.3. General Packing Weights and Dimensions.....280**
 - 5.3.1. Standard Packing.....280
 - 5.3.2. Export Packing.....281

5.1. Drawings and dimensions

Overview

ABB low voltage NEMA motors are built to meet the dimension criteria set by the NEMA MG-1 standards. Mounting dimensions will be per NEMA unless otherwise noted. Seals may alter the expected usable shaft length of the motor. When INPRO seal is selected or when a product has a standard INPRO seal the usable shaft length will be equal to the N-W less the values shown in Table 5.1. Dimensions in this section are typical dimensions of standard motor designs and are subject to change without notification. Certified standard and configured drawings are available through order codes listed in the modification section.

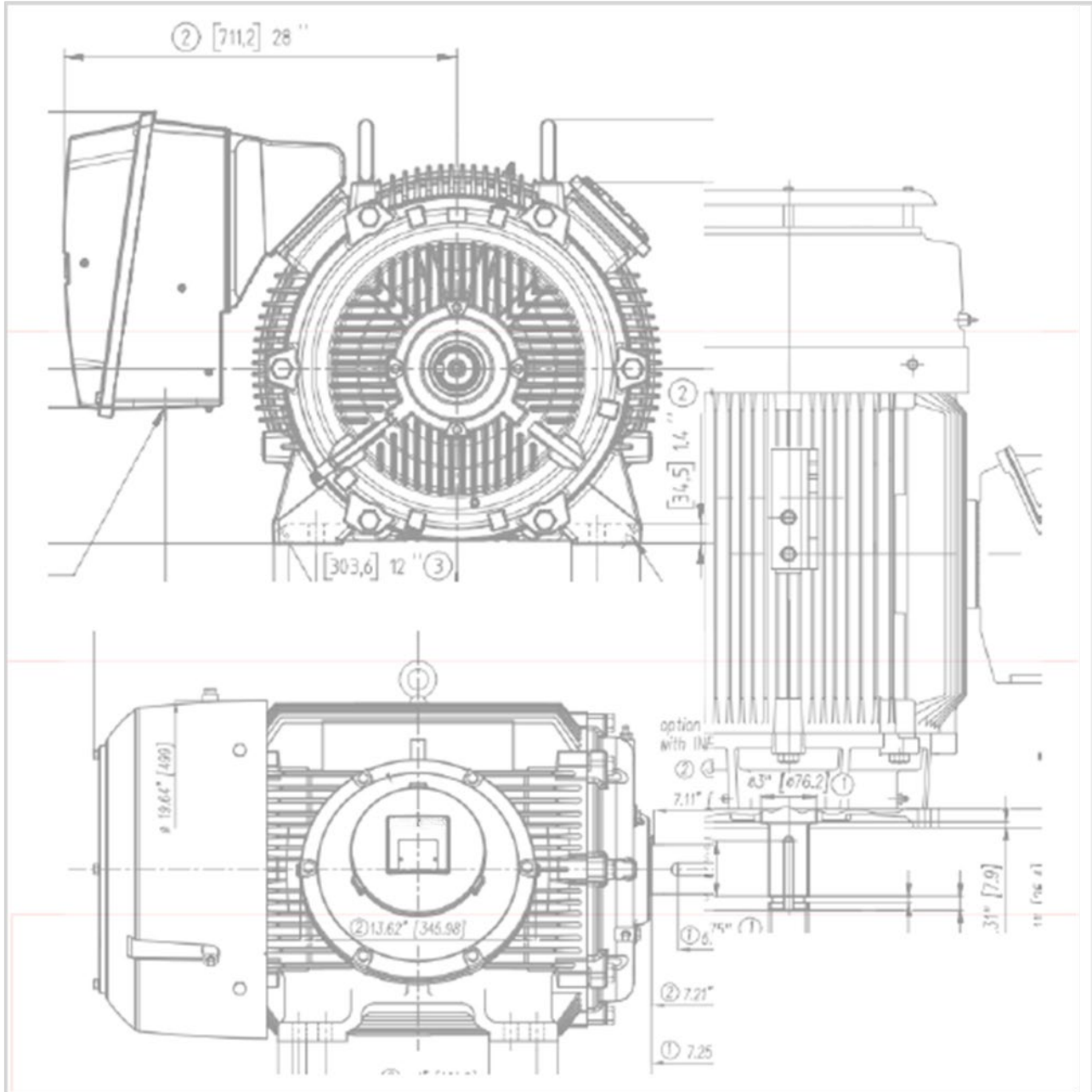

5.1.1. Next Generation – Schematics

5.1.1.1. SD200, SD200 841 – 444 – L449 Frame

Foot Mount

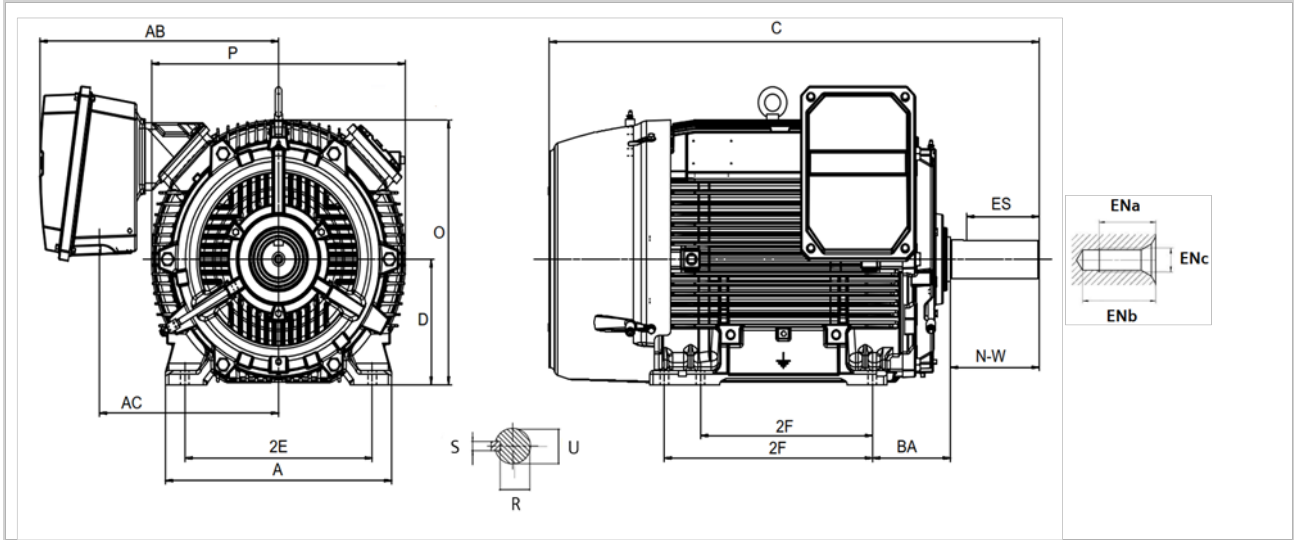

C-Face

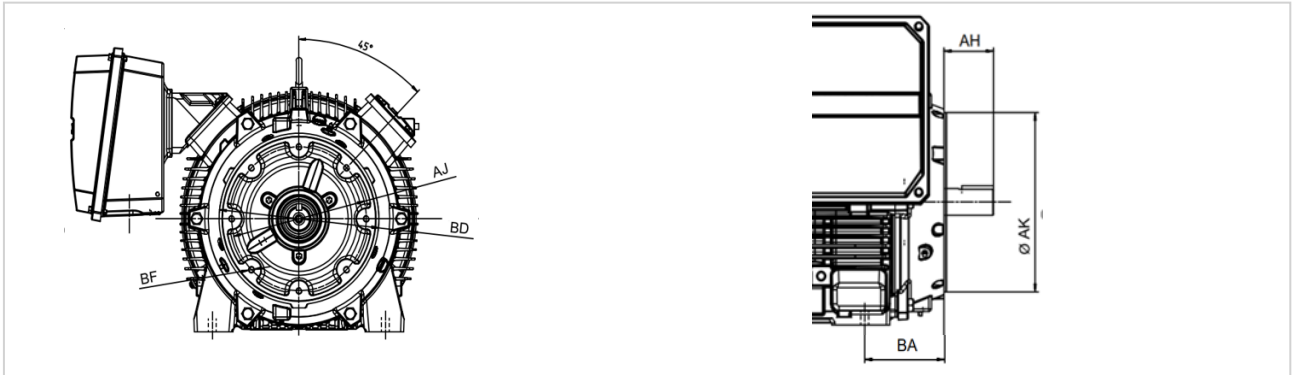

D-Flange

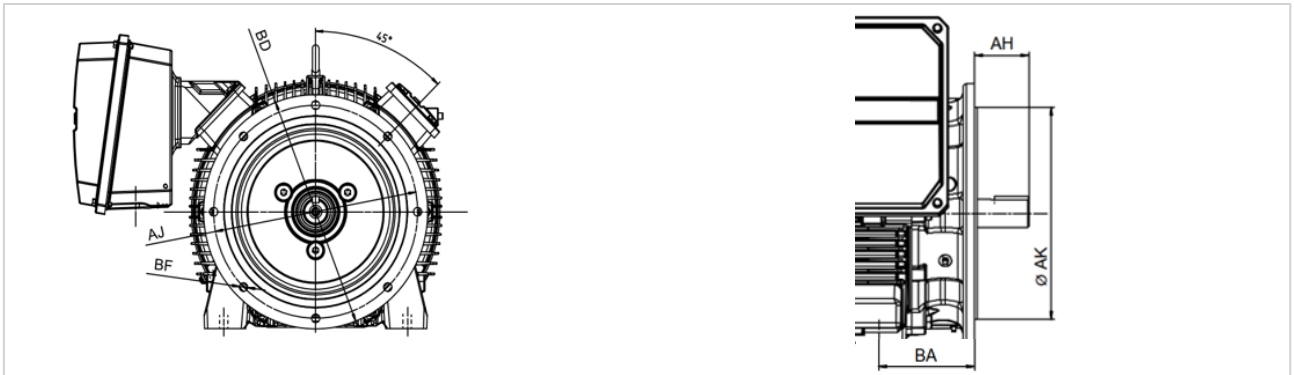

Dimension in Inches; Typical dimensions data, not guaranteed

Note: See Technical Notes for drip cover and accessory dimensions

Frame	A	C	2F	2F ¹	P	BA	AB	AC	2E	D	O
444T	21.76	43.6	14.5	16.5	24.39	7.5	22.93	17.21	18	11	23.19
445T	21.76	43.6	16.5	14.5	24.39	7.5	22.93	17.21	18	11	23.19
444TS	21.76	39.81	14.5	16.5	24.39	7.5	22.93	17.21	18	11	23.19
445TS	21.76	39.81	16.5	14.5	24.39	7.5	22.93	17.21	18	11	23.19
447T	21.76	47.03	20	16.5	24.39	7.5	22.93	17.21	18	11	23.19
447TS	21.76	43.28	20	16.5	24.39	7.5	22.93	17.21	18	11	23.19
449T	21.76	52.06	25	20	24.39	7.5	23.46	17.31	18	11	23.19
449TS	21.76	48.31	25	20	24.39	7.5	23.46	17.31	18	11	23.19
L449T	21.79	60.06	25	20	24.39	7.5	23.76	17.65	18	11	23.78
L449TS	21.79	56.43	25	20	24.39	7.5	23.76	17.65	18	11	23.78

Shaft Dimensions

Frame	N-W	U	ENa	ENb	ENC	Key seat		
						R	S	ES
444T	8.5	3.38	37	48	5/8"-11NC	2.880	0.875	6.88
445T	8.5	3.38	37	48	5/8"-11NC	2.880	0.875	6.88
444TS	4.75	2.38	37	48	5/8"-11NC	2.021	0.625	3.05
445TS	4.75	2.38	37	48	5/8"-11NC	2.021	0.625	3.05
447T	8.5	3.38	37	48	5/8"-11NC	2.880	0.875	6.88
447TS	4.75	2.38	37	48	5/8"-11NC	2.021	0.625	3.05
449T	8.5	3.38	37	48	5/8"-11NC	2.880	0.875	6.88
449TS	4.75	2.38	37	48	5/8"-11NC	2.021	0.625	3.05
L449T	8.5	3.38	37	48	5/8"-11NC	2.880	0.875	6.88
L449TS	4.75	2.38	37	48	5/8"-11NC	2.021	0.625	3.05

C-Face

Frame	BA	AH	AJ	AK	BD	BF #	BF
444TC	7.5	8.25	14	16	18	8	5/8"-11 NC
445TC	7.5	8.25	14	16	18	8	5/8"-11 NC
444TSC	7.5	4.5	14	16	18	8	5/8"-11 NC
445TSC	7.5	4.5	14	16	18	8	5/8"-11 NC
447TC	7.5	8.25	14	16	18	8	5/8"-11 NC
447TSC	7.5	4.5	14	16	18	8	5/8"-11 NC
449TC	7.5	8.25	14	16	18	8	5/8"-11 NC
449TSC	7.5	4.5	14	16	18	8	5/8"-11 NC
L449TC	7.5	8.25	14	16	18	8	5/8"-11 NC
L449TSC	7.5	4.5	14	16	18	8	5/8"-11 NC

D-Flange

Frame	C	BA ²	AH	AJ	AK	BD	BF #	BF
444TD	44.47	8.38	8.50	20	18	22	8	0.81
445TD	44.47	8.38	8.50	20	18	22	8	0.81
444TSD	40.72	8.38	4.75	20	18	22	8	0.81
445TSD	40.72	8.38	4.75	20	18	22	8	0.81
447TD	47.94	8.38	8.50	20	18	22	8	0.81
447TSD	44.19	8.38	4.75	20	18	22	8	0.81
449TD	52.98	8.38	8.50	20	18	22	8	0.81
449TSD	49.23	8.38	4.75	20	18	22	8	0.81
L449TD	61.60	8.38	8.50	20	18	22	8	0.81
L449TSD	57.85	8.38	4.75	20	18	22	8	0.81

2. Not according to NEMA

Dimension in Inches; Typical dimensions data, not guaranteed

Note: See Technical Notes for drip cover and accessory dimensions

Note: D-Flange may change standard "C" dimension as noted

5.1.1.2. SD200, DP200 HPS – 500 Frame

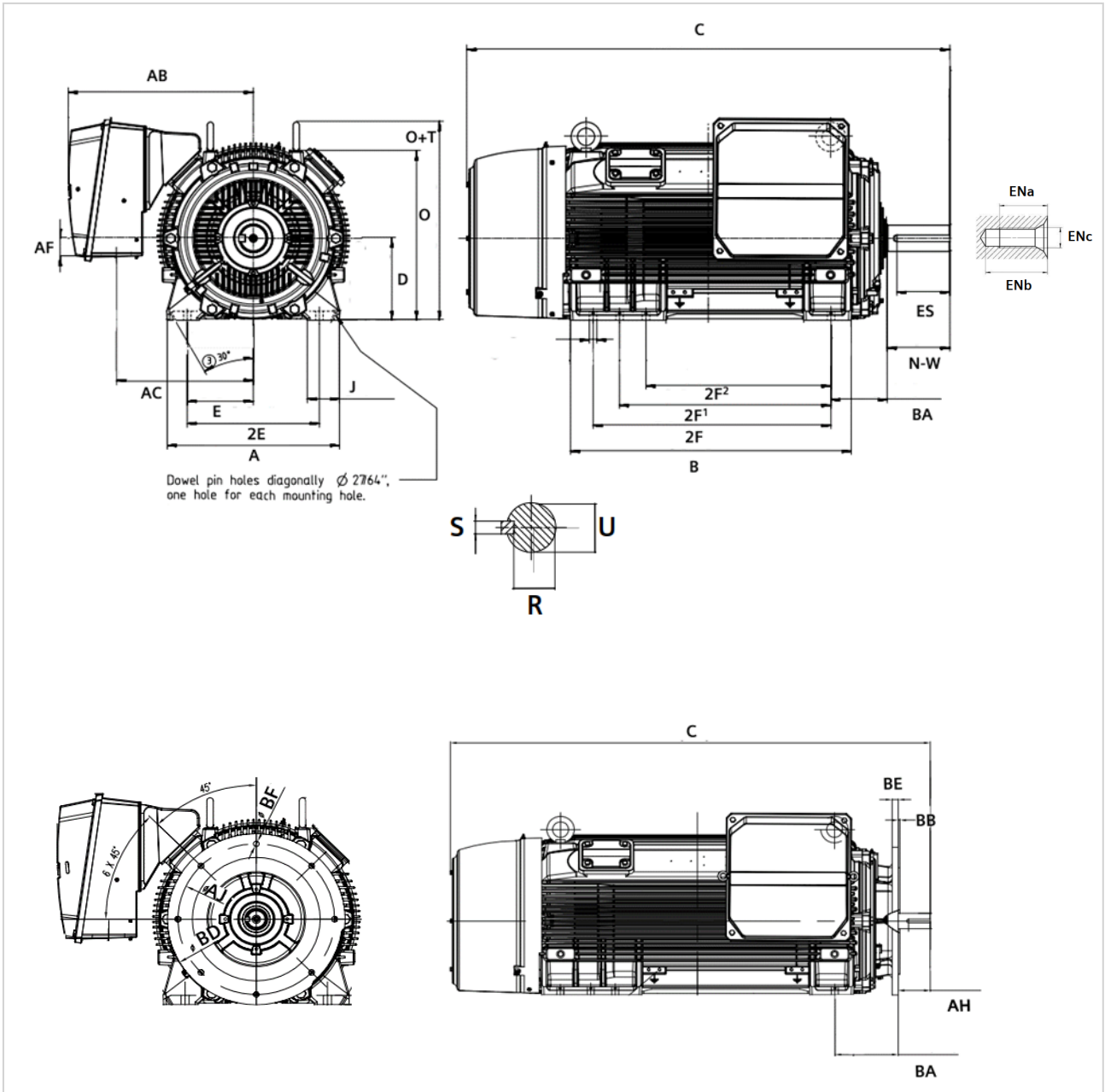

Dimension in Inches; Typical dimensions data, not guaranteed

Note: See Technical Notes for drip cover and accessory dimensions

Frames	A	2E	AC	AB	AF	O	D	C	2F	2F ¹	2F ²	B	BA
509									–	–	28		
5010	26.1	20.00	20.70	28.00	2.80	25.7	12.5	73.1	–	32	–	42.5	8.5
5011									36.00	–	–		
L5011									–	–	36.00		
5012	26.1	20.00	20.70	28.00	2.80	25.7	12.5	81	–	40.00	–	51.1	8.5
5013									45.00	–	–		
509S									–	–	28.00		
5010S	26.1	20.00	20.70	28.00	2.80	25.7	12.5	81	–	32.00	–	42.5	8.5
5011S									36.00	–	–		
L5011S									–	–	36.00		
5012S	26.1	20.00	20.70	28.00	2.80	25.7	12.5	81	–	40.00	–	51.1	8.5
5013S									45.00	–	–		

Shaft Dimensions

Frame	N-W	U	ENa	ENb	ENC	Keyseat		
						R	S	ES
509-5013	9.5	4.00	47	58	5/8"-11NC	3.4	1.000	8.0
509S-5013S	5.2	2.625	47	58	5/8"-11NC	2.275	625	3.6

D-Flange

Frame	BD	AJ	C	BA ³	AH	BE	BB	BF
509D – 5011D	25	22.00	73.99	10.37	8.50	1.00	0.25	0.81
L5011D – 5013D	25	22.00	81.89	10.37	8.50	1.00	0.25	0.81
509SD – 5011SD	25	22.00	70.80	10.37	5.25	1.00	0.25	0.81
L5011SD – 5013SD	25	22.00	78.60	10.37	5.25	1.00	0.25	0.81

3. Not according to NEMA

Dimension in Inches; Typical dimensions data, not guaranteed

Note: See Technical Notes for drip cover and accessory dimensions

Note: D-Flange may change standard “C” dimension

5.1.2. Low Voltage NEMA Motors – Schematics

5.1.2.1. GP100A, GP100 – 140-320 Frame

140-250 Frame Foot Mount

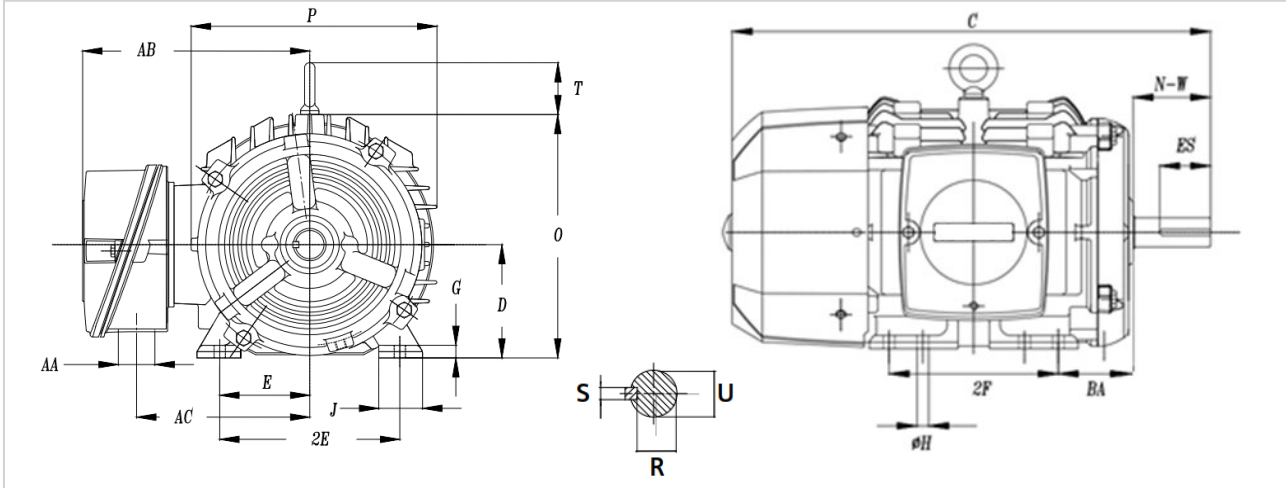

280-320 Frame Foot Mount

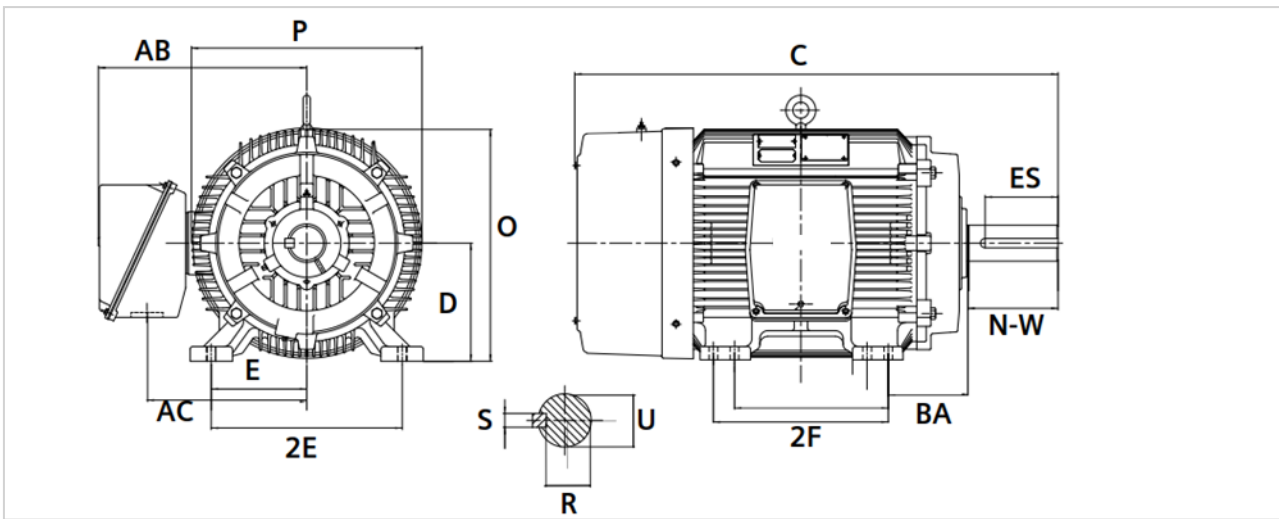

C-Face

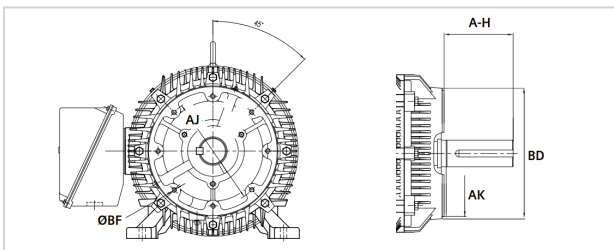

D-Flange

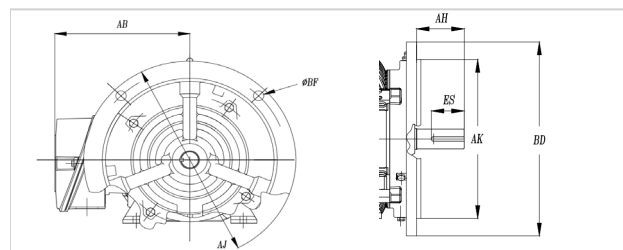

Dimension in Inches; Typical dimensions data, not guaranteed

Note: See Technical Notes for drip cover and accessory dimensions

Frame Dimensions

Frame	C	2F	P	BA	AB	2E	D	O
143T 145T	13.44	4.0 5.5	7.98	2.25	6.9	5.5	3.5	7.55
182T 184T	15.74	4.5 5.5	9.6	2.75	7.8	7.5	4.5	11.10
213T 215T	19.15	5.5 7.0	11.19	3.5	9.25	8.5	5.25	10.66
254T 256T	26.16	8.25 10.0	12.9	4.25	10.20	10.0	6.25	12.75
284T 286T	29.38	9.5 11.0	15.8	4.75	13.63	11.0	7	14.87
284TS 286TS	28.00	8.5 11.0	15.8	4.75	13.63	11.0	7	14.87
324T 326T	32.07	10.5 12.0	17.7	5.25	14.14	12.5	8	16.66
324TS 326TS	30.57	10.5 12.0	17.7	5.25	14.14	12.5	8	16.66

Shaft Dimensions

Frame	N-W	U	ENa	ENb	ENc	Keyseat		
						R	S	ES
143T-145T	2.25	0.875	–	–	–	0.771	0.188	1.41
182T-184T	2.75	1.125	–	–	–	0.986	0.250	1.81
213T-215T	3.38	1.375	–	–	–	1.201	0.312	2.44
254T-256T	4	1.625	–	–	–	1.416	0.375	2.91
284T-286T	4.63	1.875	28	34	7/16"-14NC	1.59	0.500	3.25
284TS-286TS	3.25	1.625	28	34	7/16"-14NC	1.42	0.375	1.88
324T-324TS	5.25	2.125	28	34	7/16"-14NC	1.85	0.500	3.88
324TS-326TS	3.75	1.785	28	34	7/16"-14NC	1.59	0.500	2

C-Face

Frame	BA*	AH	AJ	AK	BD	BF #	BF
143/5TC	2.25	2.12	5.875	4.5	6.60*	4	3/8-16" NC
182/4TC	2.75	2.62	7.25	8.5	8.90	4	1/2-13" NC
213/5TC	3.5	3.12	7.25	8.9	8.90	4	1/2-13" NC
254/6TC	4.25	3.75	7.25	8.5	9.30	4	1/2-13" NC
284/6TC	4.75	4.38	9.00	10.5	11.25	4	1/2-13" NC
284/6TSC	4.75	3	9.00	10.5	11.25	4	1/2-13" NC
324/6TC	5.25	5	11.00	12.5	14.00	4	5/8-11" NC
324/6TSC	5.25	3.5	11.00	12.5	14.00	4	5/8-11" NC

D-Flange

Frame	BA ¹	AH	AJ	AK	BD	BF #	BF
143/5TD	2.25	2.25	10.0	9.0	10.90	4	0.53
182/4TD	2.75	2.75	10.0	9.0	11.00	4	0.53
213/5TD	3.50	3.38	10.0	9.0	10.90	4	0.53
254/6TD	4.25	4.00	12.5	11.0	13.90	4	0.81
284/6TD	5.88	4.62	12.5	11.0	14.00	4	0.81
284/6TSD	5.88	3.25	12.5	11.0	14.00	4	0.81
324/6TD	6.25	5.25	16	14.0	18.00	4	0.81
324/6TSD	6.25	3.75	16	14.0	18.00	4	0.81

1. Not according to NEMA

Dimension in Inches; Typical dimensions data, not guaranteed

Note: See Technical Notes for drip cover and accessory dimensions

Note: D-Flange may change standard “C” dimension

5.1.2.2. GP100 – 360 - 440 Frame

360-440 Frame Foot Mount

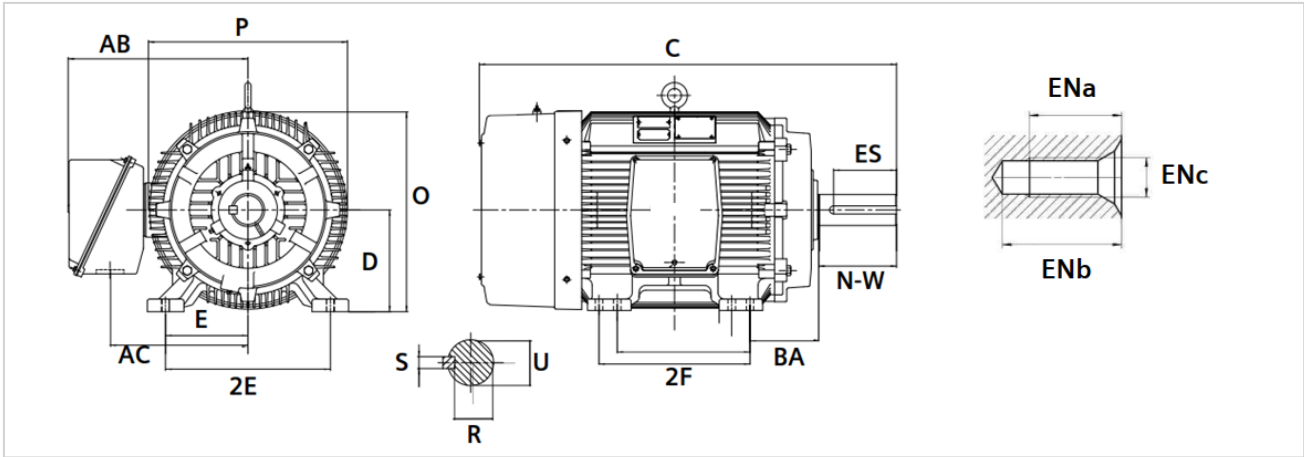

C-Face

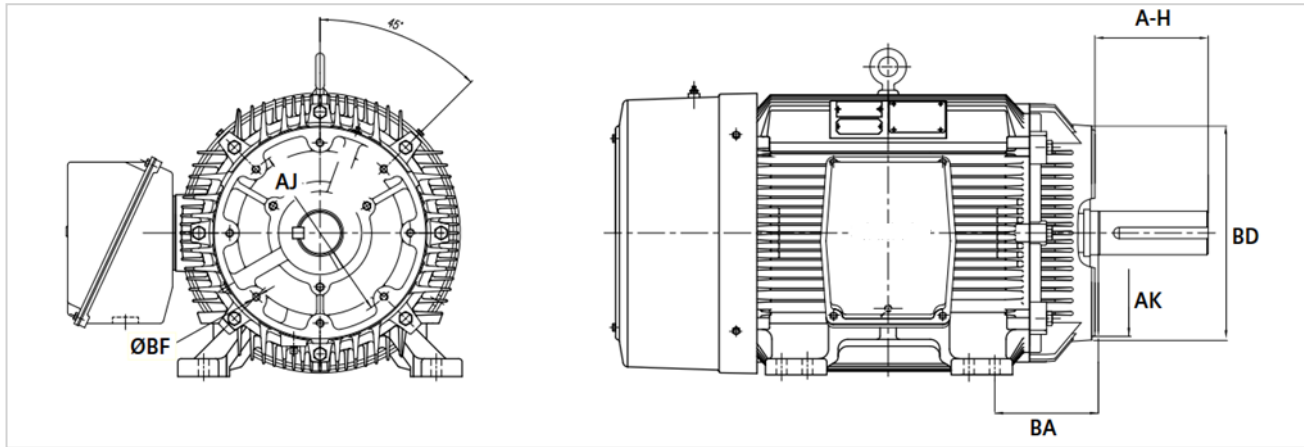

D-Flange

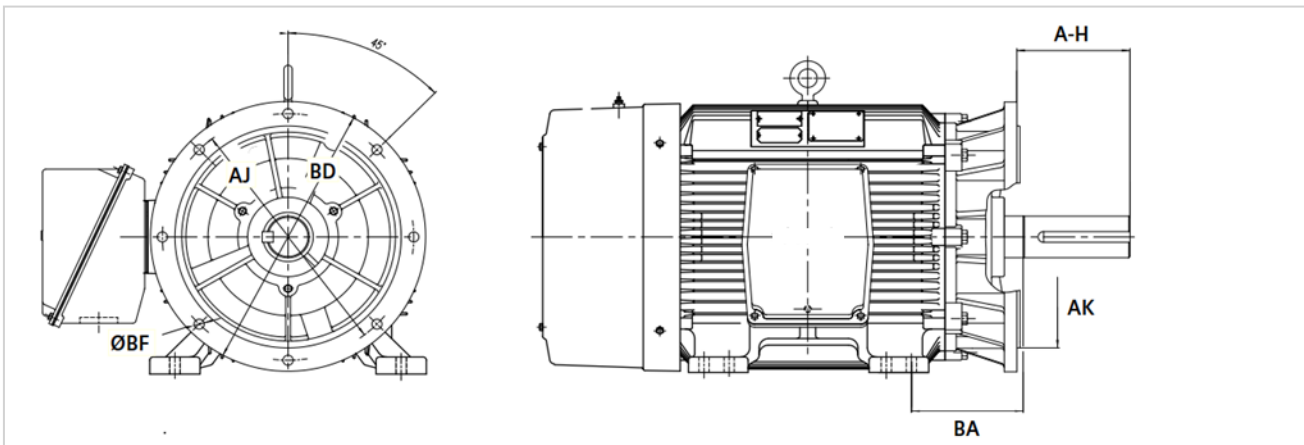

Dimension in Inches; Typical dimensions data, not guaranteed

Note: See Technical Notes for drip cover and accessory dimensions

Frame Dimensions

Frame	C	2F	P	BA	AB	2E	D	O
364T	35.53	11.25	19.6	5.88	17.56	14.0	9	18.48
365T		12.3						
364TS	33.40	11.3	19.6	5.88	17.56	14.0	9	18.48
365TS		12.25						
404T	39.50	12.25	19.6	6.62	17.68	16.0	10	19.60
405T		13.75						
404TS	36.50	12.25	19.6	6.62	17.68	16.0	10	19.60
405TS		13.75						
444T	45.60	14.50	21.8	7.5	18.88	18.0	11	21.80
445T		16.5						
444TS	41.80	14.50	21.8	7.5	18.88	18.0	11	21.80
445TS		16.5						
447T	49.10	20.00	21.8	7.5	18.88	18.0	11	21.80
447TS	45.40	20.00	21.8	7.5	18.88	18.0	11	21.80
449T	54.10	25.00	21.8	7.5	18.88	18.0	11	21.80
449TS	50.30	25.00	21.8	7.5	18.88	18.0	11	21.80

Shaft Dimensions

Frame	N-W	U	ENa	ENb	ENC	Keyseat		
						R	S	ES
364T - 365T	5.88	2.375	30	36	7/16"-14NC	2.02	0.625	4.25
364TS - 365TS	3.75	1.875	30	36	7/16"-14NC	1.59	0.500	2
404T - 405T	7.25	2.875	30	36	7/16"-14NC	2.45	0.750	5.63
404TS - 405TS	4.25	2.125	30	36	7/16"-14NC	1.85	0.500	2.75
444T - 449T	8.5	3.375	37	48	5/8"-11NC	2.88	0.875	6.88
444TS - 449TS	4.75	2.375	37	48	5/8"-11NC	2.02	0.625	3

C-Face

Frame	BA ¹	AH	AJ	AK	BD	BF #	BF
364/5TC	5.88	5.63	11	12.5	14	8	5/8-11" NC
364/5TSC	5.88	3.5	11.00	12.5	14.00	8	5/8-11" NC
404/5TC	6.62	7	11.00	12.5	15.50	8	5/8-11" NC
404/5TSC	6.62	4	11.00	12.5	15.50	8	5/8-11" NC
444TC	7.5	8.25	14.00	16	18.00	8	5/8-11" NC
445TSC	7.5	8.25	14.00	16	18.00	8	5/8-11" NC
444TSC	7.5	4.5	14.00	16	18.00	8	5/8-11" NC
445TSC	7.5	4.5	14.00	16	18.00	8	5/8-11" NC
447TC	7.5	8.25	14.00	16	18.00	8	5/8-11" NC
447TSC	7.5	4.5	14.00	16	18.00	8	5/8-11" NC
449TC	7.5	8.25	14.00	16	18.00	8	5/8-11" NC
449TSC	7.5	4.5	14.00	16	18.00	8	5/8-11" NC

D-Flange

Frame	BA ¹	AH	AJ	AK	BD	BF #	BF
364/5TD	6.75	5.88	16.0	14.0	18.00	4	0.81
364/5TSD	6.75	3.75	16.0	14.0	18.00	4	0.81
404/5TD	7.12	7.25	20.0	18.0	22.00	8	0.81
404/5TSD	7.12	4.25	20	18.0	22.00	8	0.81
444TD	8.38	8.50	20	18.0	22.00	8	0.81
445TSD	8.38	8.50	20	18.0	22.00	8	0.81
444TSD	8.38	4.75	20	18.0	22.00	8	0.81
445TSD	8.38	4.75	20	18.0	22.00	8	0.81
447TD	8.38	8.50	20	18.0	22.00	8	0.81
447TSD	8.38	4.75	20	18.0	22.00	8	0.81
449TD	8.38	8.50	20	18.0	22.00	8	0.81
449TSD	8.38	4.75	20	18.0	22.00	8	0.81

1. Not according to NEMA

Dimension in Inches; Typical dimensions data, not guaranteed

Note: See Technical Notes for drip cover and accessory dimensions

Note: D-Flange may change standard “C” dimension

5.1.2.3. SD100 – 140 – 320 Frame

140-250 Frame Foot Mount

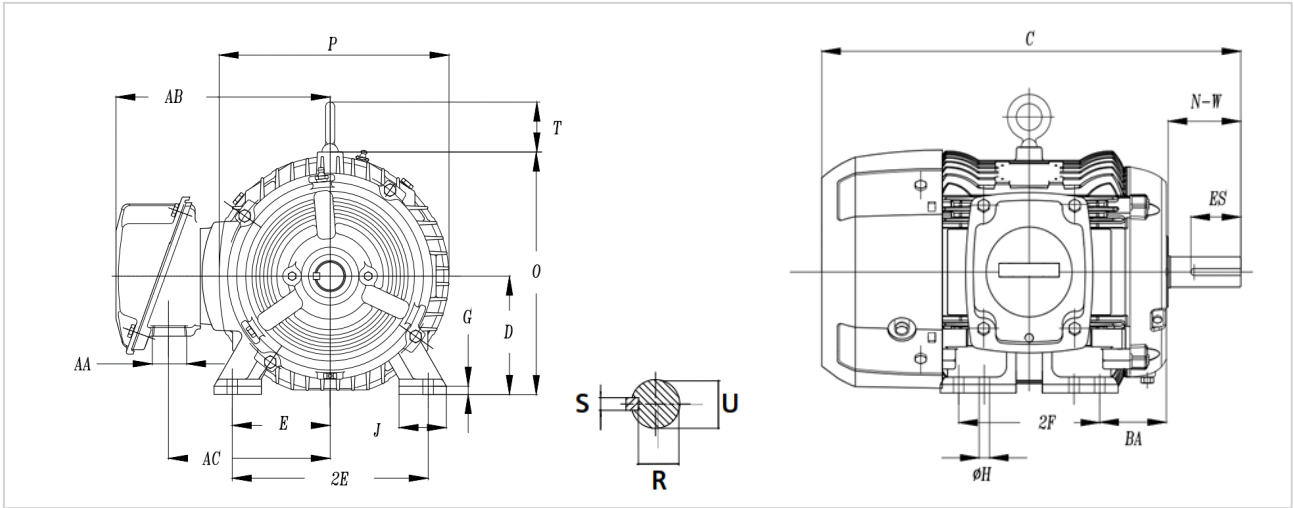

280-320 Frame Foot Mount

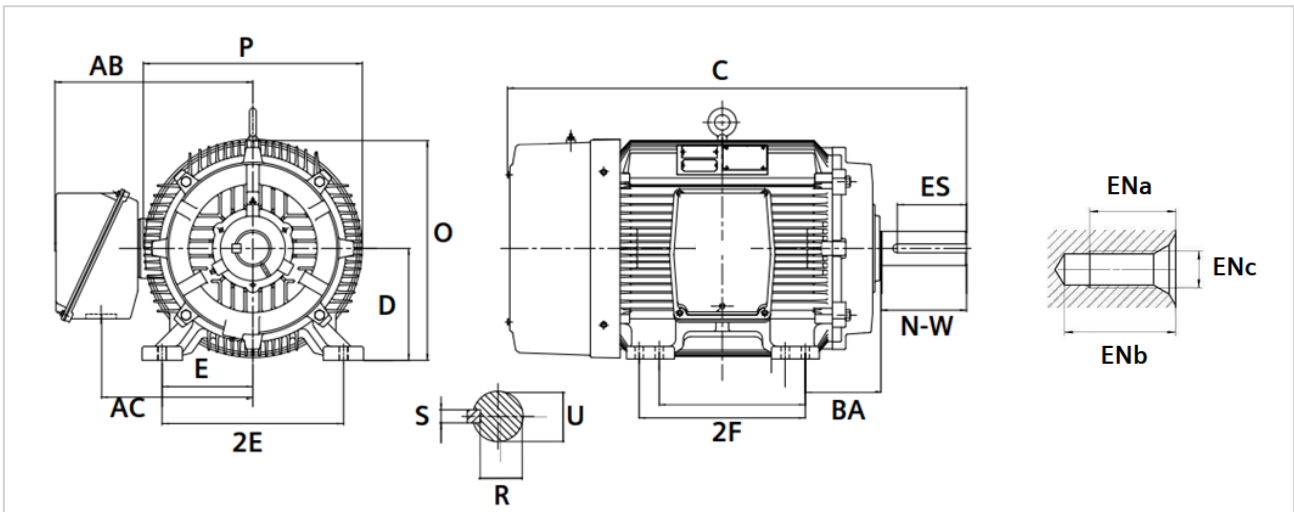

C-Face

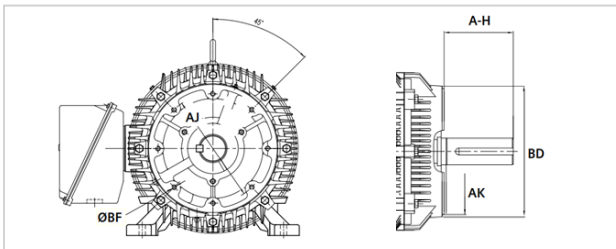

D-Flange

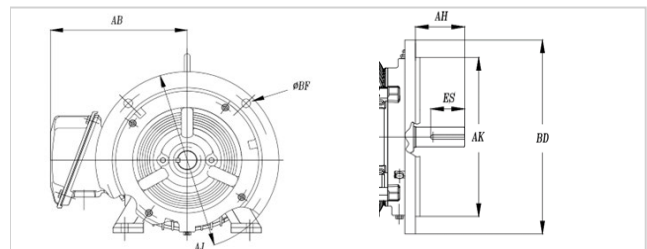

Dimension in Inches; Typical dimensions data, not guaranteed.

Note: See Technical Notes for drip cover and accessory dimensions

Frame Dimensions

Frame	C	2F	P	BA	AB	2E	D	O
143T 145T	14.20	4.0 5.0	8.2	2.25	7.4	5.5	3.5	7.50
182T 184T	16.40	4.5 5.5	9.6	2.75	8.2	7.5	4.5	11.10
213T 215T	20.20	5.5 7.0	10.7	3.5	10.39	8.5	5.25	10.66
254T 256T	25.80	8.25 10.0	12.9	4.25	11.14	10.0	6.25	12.75
284T 286T	29.40	9.5 11.0	15.8	4.75	14.3	11.0	7	14.87
284TS 286TS	28.00	9.5 11.0	15.8	4.75	14.33	11.0	7	14.87
324T 326T	32.10	10.5 12.0	17.7	5.25	15.99	12.5	8	16.66
324TS 326TS	30.60	10.50 12.0	17.7	5.25	15.99	12.5	8	16.66

Shaft Dimensions

Frame	N-W	U	ENa	ENb	ENC	Keyseat		
						R	S	ES
143T-145T	2.25	0.875	–	–	–	0.771	0.188	1.41
182T-184T	2.75	1.125	–	–	–	0.986	0.250	1.81
213T-215T	3.38	1.375	–	–	–	1.201	0.312	2.44
254T-256T	4	1.625	–	–	–	1.416	0.375	2.91
284T-286T	4.63	1.875	28	34	7/16"-14NC	1.59	0.500	3.25
284TS-286TS	3.25	1.625	28	34	7/16"-14NC	1.42	0.375	1.88
324T-324TS	5.25	2.125	28	34	7/16"-14NC	1.85	0.500	3.88
324TS-326TS	3.75	1.875	28	34	7/16"-14NC	1.59	0.500	2

C-Face

Frame	BA ¹	AH	AJ	AK	BD	BF #	BF
143/5TC	2.25	2.12	5.875	4.5	6.5	4	3/8"-16 NC
182/4TC	2.75	2.62	7.25	8.5	9.00	4	1/2"-13 NC
213/5TC	3.5	3.12	7.25	8.5	9.00	4	1/2"-13 NC
254/6TC	4.25	3.75	7.25	8.5	10.00	4	1/2"-13 NC
284/6TC	4.75	4.38	9.00	10.5	11.25	4	1/2"-13 NC
284/6TSC	4.75	3	9.00	10.5	11.25	4	1/2"-13 NC
324/6TC	5.25	5	11.00	12.5	14.00	4	5/8"-11 NC
324/6TSC	5.25	3.5	11.00	12.5	14.00	4	5/8"-11 NC

D-Flange

Frame	BA ¹	AH	AJ	AK	BD	BF #	BF
143/5TD	2.25	2	10.0	9.0	11.00	4	0.53
182/4TD	2.75	2.5	10.0	9.0	11.00	4	0.53
213/5TD	3.5	3.13	10	9.0	11.00	4	0.53
254/6TD	4.25	3.75	12.5	11.0	14.00	4	0.53
284/6TD	5.88	4.37	12.5	11.0	14.00	4	0.53
284/6TSD	5.88	4.38	12.5	11.0	14.00	4	0.81
324/6TD	6.25	5.00	16	14.0	18.00	4	0.81
324/6TSD	6.25	5.00	16	14.0	18.00	4	0.81

1. Not according to NEMA

Dimension in Inches; Typical dimensions data, not guaranteed

Note: See Technical Notes for drip cover and accessory dimensions

Note: D-Flange may change standard “C” dimension

5.1.2.4. SD100 – 360 – S440 Frame

360-440 Frame Foot Mount

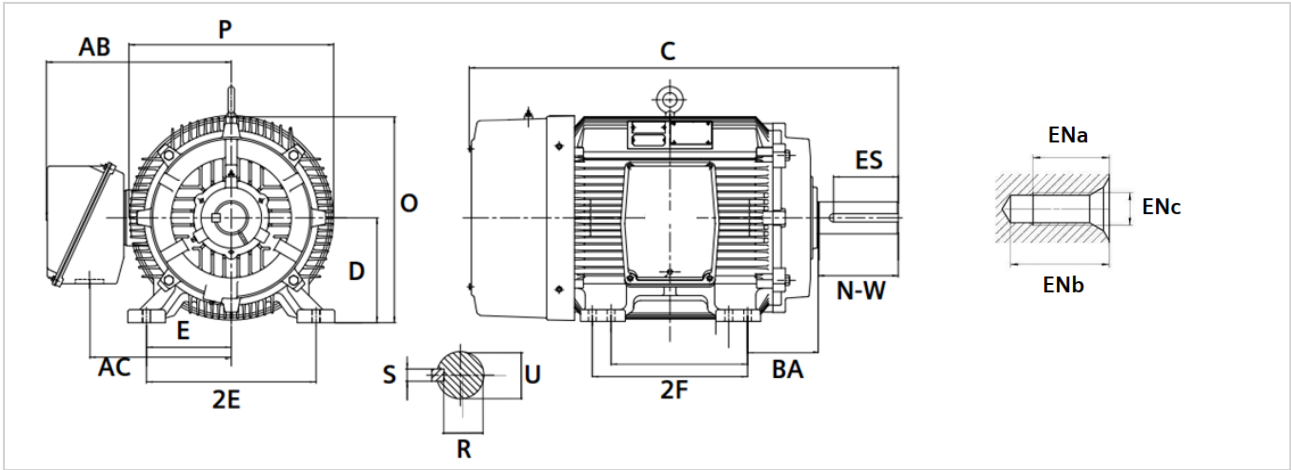

C-Face

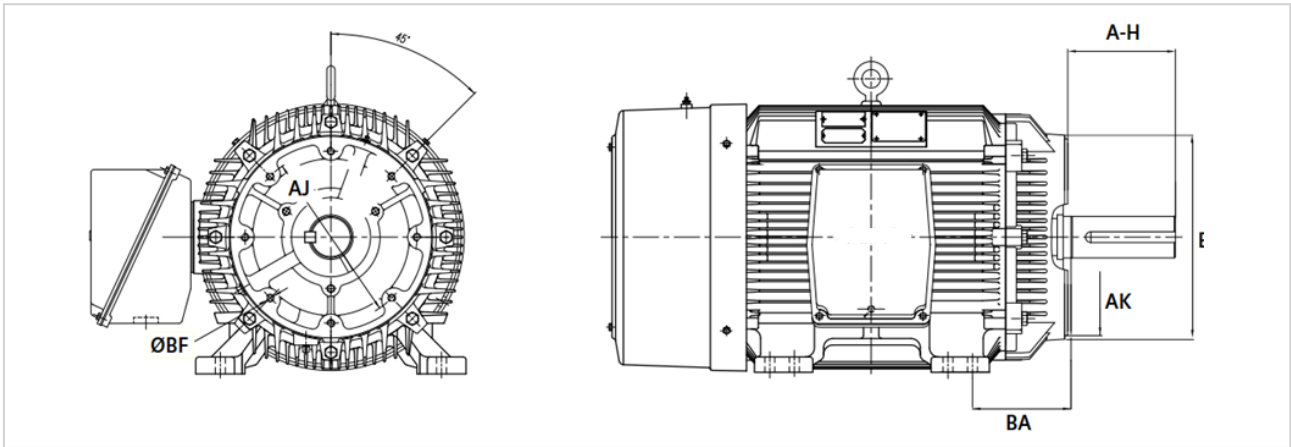

D-Flange

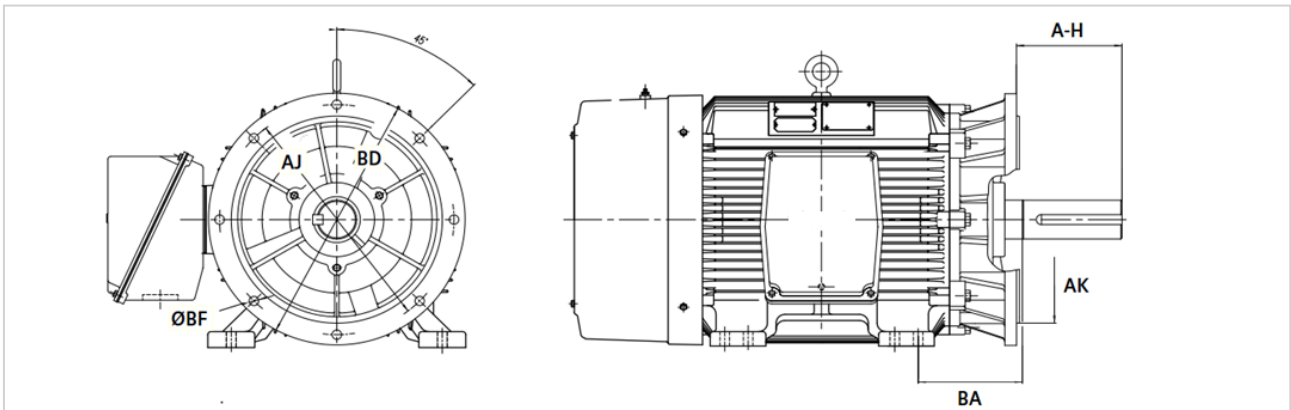

Dimension in Inches; Typical dimensions data, not guaranteed

Note: See Technical Notes for drip cover and accessory dimensions

Frame Dimensions

Frame	C	2F	P	BA	AB	2E	D	O
364T	35.50	11.25	19.6	5.88	18.57	14.0	9	18.48
365T		12.25						
364TS	33.40	11.25	19.6	5.88	18.57	14.0	9	18.48
365TS		12.25						
404T	39.40	12.25	19.6	6.62	18.38	16.0	10	19.60
405T		13.75						
404TS	36.40	12.25	19.6	6.62	18.38	16.0	10	19.60
405TS		13.75						
444T	45.60	14.5	21.8	7.5	19.63	18.0	11	21.80
445T		16.5						
444TS	41.80	14.5	21.8	7.5	19.63	18.0	11	21.80
445TS		16.5						
447T	49.00	20.00	21.8	7.5	19.63	18.0	11	22.00
447TS	45.30	20.00	21.8	7.5	19.63	18.0	11	22.00
449T	54.00	25.00	21.8	7.5	22	18.0	11	22.00
449TS	50.30	25.00	21.8	7.5	22	18.0	11	22.00
S449LS	63.60	25.00	24.6	7.5	23	18.0	11	23.30
S449SS	59.80	25.00	24.6	7.5	23	18.0	11	23.30
S449SS ¹	63.20	25.00	24.6	7.5	23	18.0	11	23.30

Shaft Dimensions

Frame	N-W	U	ENa	ENb	ENc	Keyseat		
						R	S	ES
364T - 365T	5.88	2.375	30	36	7/16"-14NC	2.02	0.625	4.25
364TS - 365TS	3.75	1.875	30	36	7/16"-14NC	1.59	0.500	2
404T - 405T	7.25	2.875	30	36	7/16"-14NC	2.45	0.750	5.63
404TS - 405TS	4.25	2.125	30	36	7/16"-14NC	1.85	0.500	2.75
444T - 449T	8.5	3.375	37	48	5/8"-11NC	2.88	0.875	6.88
444TS - 449TS	4.75	2.375	37	48	5/8"-11NC	2.02	0.625	3
S449LS	9.12	3.625	37	48	5/8"-11NC	3.134	0.875	7.5
S449SS	5.25	2.625	37	48	5/8"-11NC	2.275	0.625	3.5

C-Face

Frame	BA ¹	AH	AJ	AK	BD	BF #	BF
364/5TC	5.88	5.63	11.00	12.5	12.75	8	5/8"-11 NC
364/5TSC	5.88	3.5	11.00	12.5	12.75	8	5/8"-11 NC
404/5TC	6.62	7	11.00	12.5	15.50	8	5/8"-11 NC
404/5TSC	6.62	4	11.00	12.5	15.50	8	5/8"-11 NC
444/5TC	7.5	8.25	14.00	16	18.00	8	5/8"-11 NC
444/5TSC	7.5	4.5	14.00	16	18.00	8	5/8"-11 NC
447/9TC	7.5	8.25	14.00	16	18.00	8	5/8"-11 NC
447/9TSC	7.5	4.5	14.00	16	18.00	8	5/8"-11 NC
S449LSC	7.5	8.25	14.00	16	18.00	8	5/8"-11 NC
S449SSC	7.5	4.5	14.00	16	18.00	8	5/8"-11 NC

D-Flange

Frame	BA ¹	AH	AJ	AK	BD	BF #	BF
364/5TD	6.75	5.63	16.0	14.0	18.00	4	0.81
364/5TSD	6.75	3.5	16.0	14.0	18.00	4	0.81
404/5TD	7.12	7.25	20	18.0	22.00	4	0.81
404/5TSD	7.12	4.25	20	18.0	22.00	4	0.81
444/5TD	8.38	8.50	20	18.0	22.00	8	0.81
444/5TSD	8.38	4.75	20	18.0	22.00	8	0.81
447/9TD	8.38	8.50	20	18.0	22.00	8	0.81
447/9TSD	8.38	4.75	20	18.0	22.00	8	0.81
S449LSD	8.38	8.50	20	18.0	22.00	8	0.81
S449SSD	8.38	4.75	20	18.0	22.00	8	0.81

1. Not according to NEMA

2. 2 pole only

Dimension in Inches; Typical dimensions data, not guaranteed

Note: See Technical Notes for drip cover and accessory dimensions

Note: D-Flange may change standard "C" dimension

5.1.2.5. SD100 IEEE, SD661 – 140 – 320 Frame

140-250 Frame Foot Mount

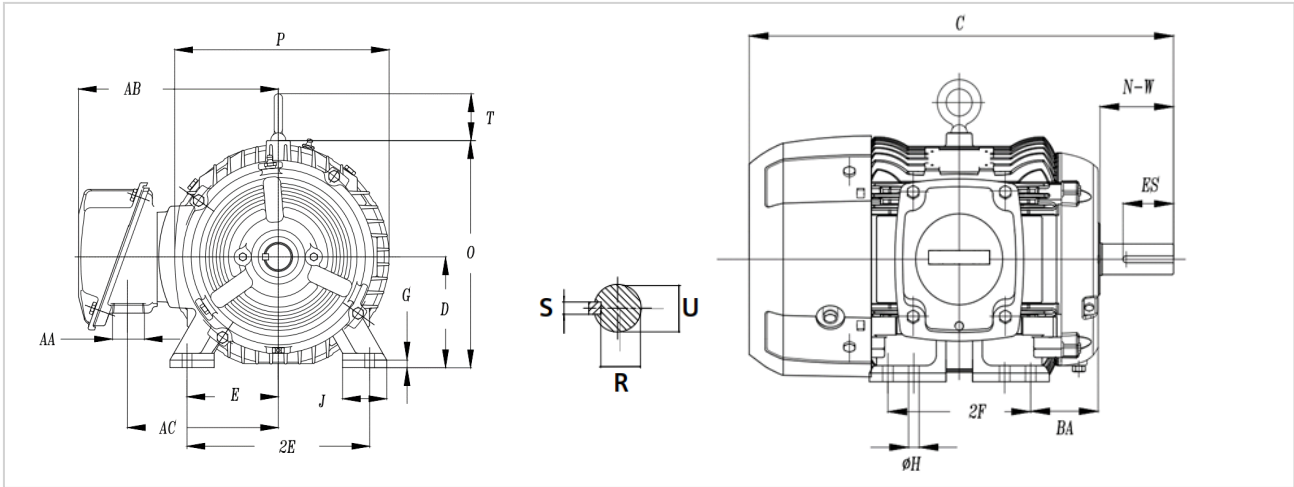

280-320 Frame Foot Mount

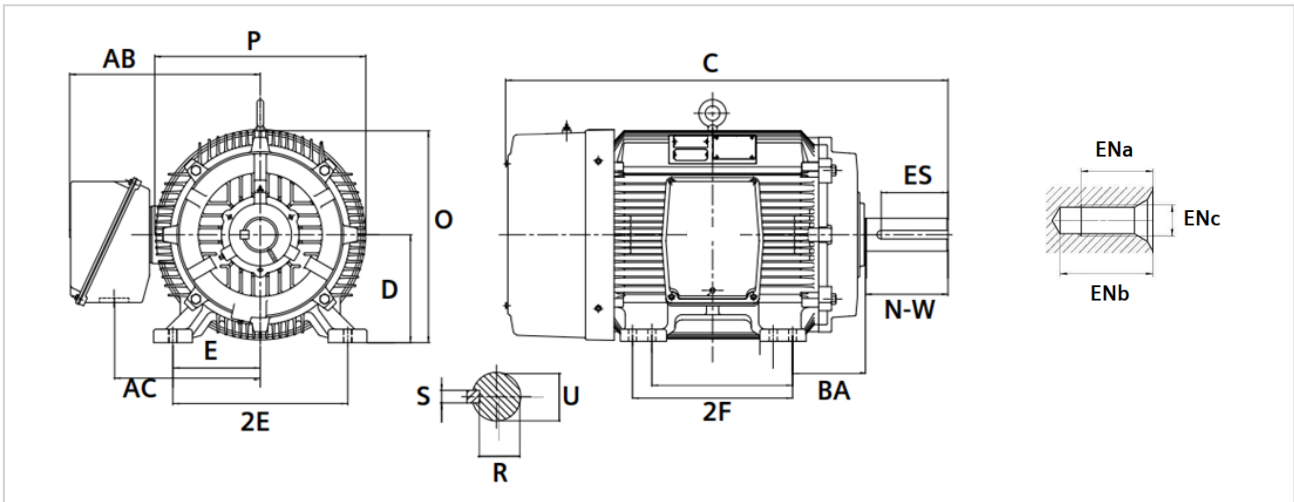

C-Face

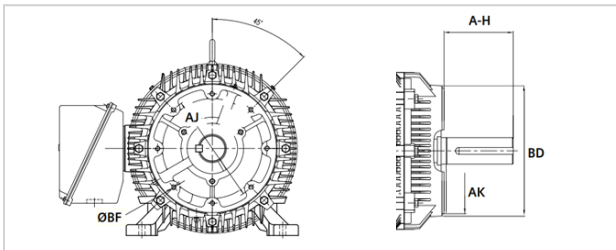

D-Flange

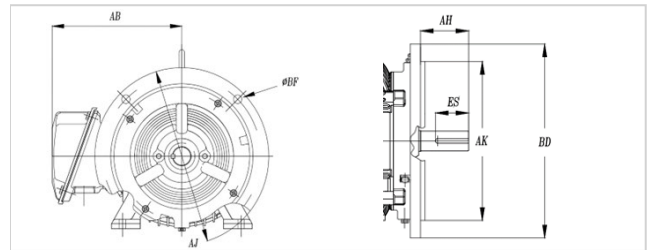

Dimension in Inches; Typical dimensions data, not guaranteed.

Note: See Technical Notes for drip cover and accessory dimensions

Frame Dimensions

Frame	C	2F	P	BA	AB	2E	D	O
143T 145T	14.00	4.0 5.0	8.1	2.25	7.05	5.5	3.5	7.42
182T 184T	16.40	4.5 5.5	10.8	3.03	8.58	7.5	4.5	9.74
213T 215T	20.30	5.5 7.0	12.2	4.03	10.63	8.5	5.25	11.35
254T 256T	25.80	8.25 10.0	14.4	4.78	11.62	10.0	6.25	13.34
284T 286T	29.40	9.5 11.0	15.8	5.29	14.3	11.0	7	14.87
284TS 286TS	28.00	9.5 11.0	15.8	5.28	14.33	11.0	7	14.87
324T 326T	32.10	10.5 12.0	17.7	5.4	15.99	12.5	8	16.66
324TS 326TS	30.60	10.5 12.0	17.7	5.75	15.99	12.5	8	16.66

Shaft Dimensions

Frame	N-W	U	ENa	ENb	ENc	Keyseat		
						R	S	ES
143T-145T	2.25	0.875	–	–	–	0.771	0.188	1.41
182T-184T	2.75	1.125	–	–	–	0.986	0.250	1.81
213T-215T	3.38	1.375	–	–	–	1.201	0.312	2.44
254T-256T	4	1.625	–	–	–	1.416	0.375	2.91
284T-286T	4.63	1.875	28	34	7/16"-14NC	1.59	0.500	3.25
284TS-286TS	3.25	1.625	28	34	7/16"-14NC	1.42	0.375	1.88
324T-324TS	5.25	2.125	28	34	7/16"-14NC	1.85	0.500	3.88
324TS-326TS	3.75	1.875	28	34	7/16"-14NC	1.59	0.500	2

C-Face

Frame	BA ¹	AH	AJ	AK	BD	BF #	BF
143/5TC	2.38	2.12	5.875	4.5	6.5	4	3/8"-16 NC
182/4TC	2.87	2.62	7.25	8.5	9.00	4	1/2"-13 NC
213/5TC	3.72	3.12	7.25	8.5	9.00	4	1/2"-13 NC
254/6TC	4.42	3.75	7.25	8.5	10.00	4	1/2"-13NC
284/6TC	5.29	4.38	9.00	10.5	11.25	4	1/2"-13NC
284/6TSC	5.29	3.00	9.00	10.5	11.25	4	1/2"-13NC
324/6TC	5.80	5.00	11.00	12.5	14.00	4	5/8"-11NC
324/6TSC	5.75	3.50	11.00	12.5	14.00	4	5/8"-11NC

D-Flange

Frame	BA ¹	AH	AJ	AK	BD	BF #	BF
143/5TD	2.38	2.25	10.0	9.0	11.00	4	0.53
182/4TD	2.87	2.75	10.0	9.0	11.00	4	0.53
213/5TD	3.72	3.32	10.0	9.0	11.00	4	0.53
254/6TD	4.42	4.00	12.5	11.0	14.00	4	0.81
284/6TD	5.88	4.62	12.5	11.0	14.00	4	0.81
284/6TSD	5.88	3.25	12.5	11.0	14.00	4	0.81
324/6TD	6.25	5.25	16.0	14.0	18.00	4	0.81
324/6TSD	6.25	3.75	16.0	14.0	18.00	4	0.81

INPRO Seals

Frame	Reduction in usable shaft
140T	0.13
180T	0.13
210T	0.21
250T	0.17
280T	0.16
280TS	0.15
320T	0.17
320TS	0.17

1. Not according to NEMA

2. Usable shaft length will be reduced by seal. See Table 5.1 for reduction in usable shaft

Dimension in Inches; Typical dimensions data, not guaranteed.

Note: See Technical Notes for drip cover and accessory dimensions

Note: D-Flange may change standard “C” dimension

5.1.2.6. SD100 IEEE, SD661 – 360 – S440 Frame

360-440 Frame Foot Mount

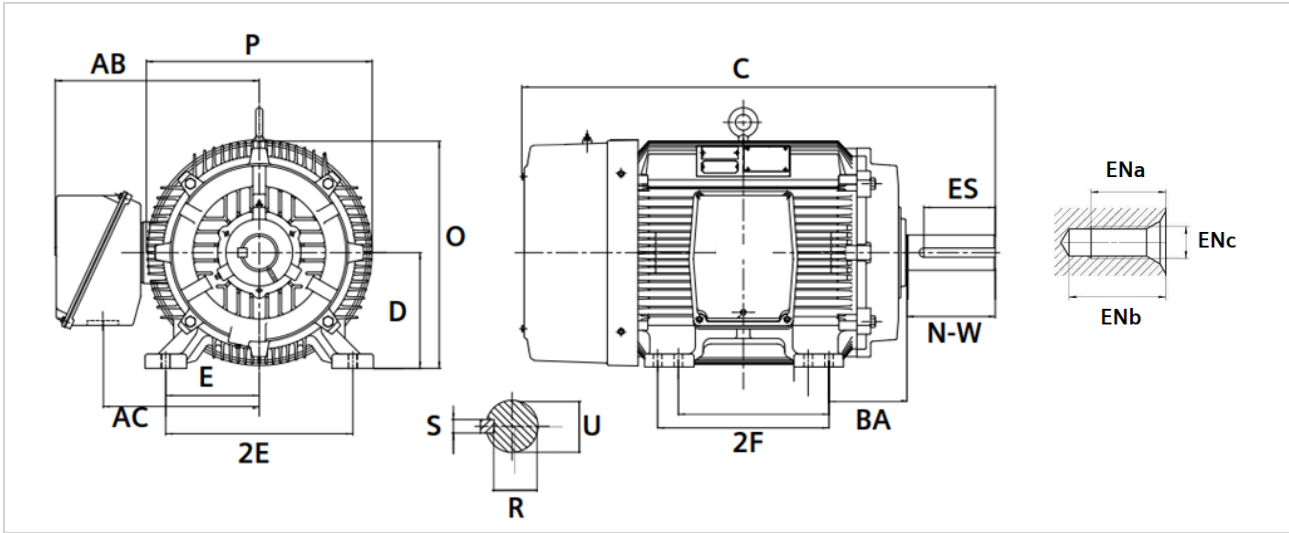

C-Face

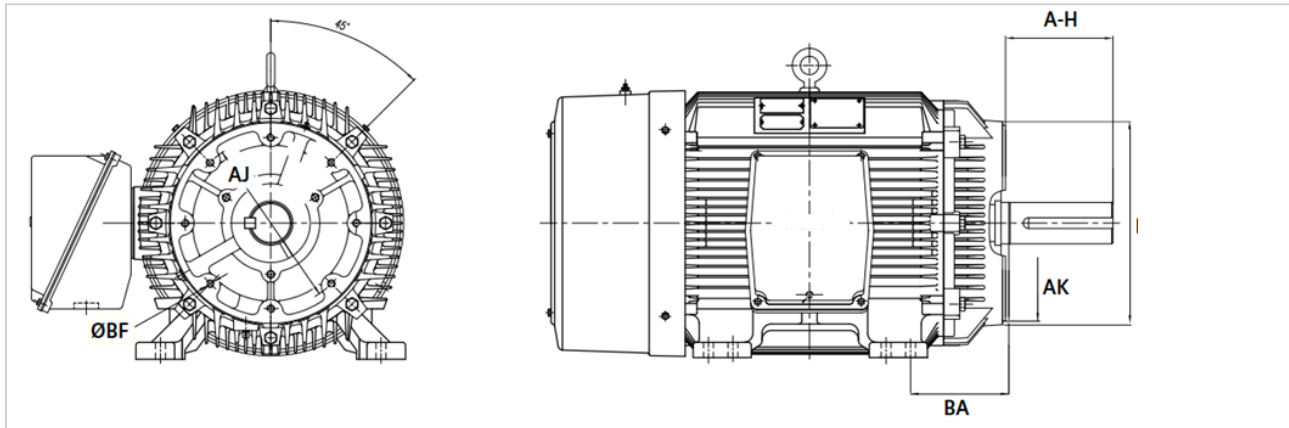

D-Flange

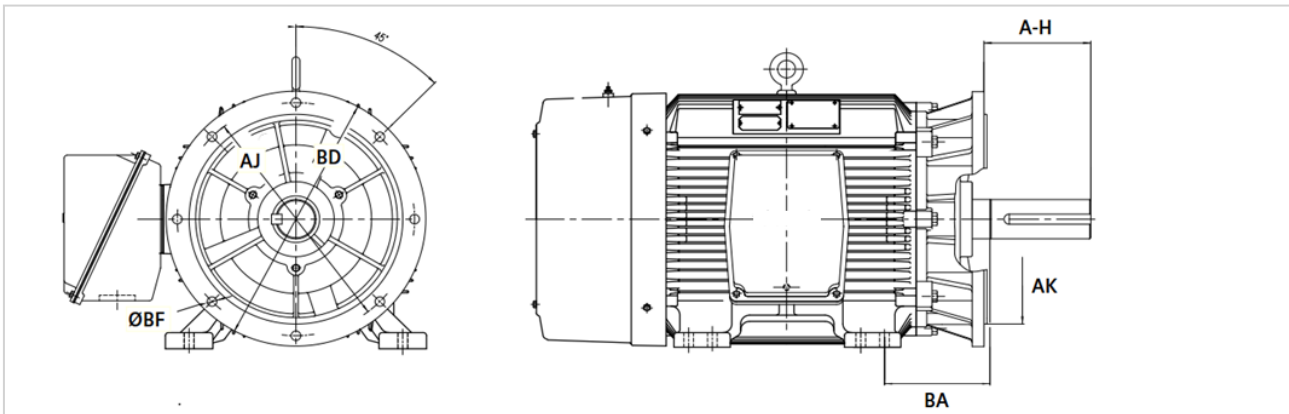

Dimension in Inches; Typical dimensions data, not guaranteed.

Note: See Technical Notes for drip cover and accessory dimensions

Frame Dimensions

Frame	C	2F	P	BA	AB	2E	D	O
364T	35.5	11.25	19.6	5.88	18.57	14.0	9	18.48
365T		12.25						
364TS	33.4	11.3	19.6	5.88	18.57	14.0	9	18.48
365TS		12.25						
404T	39.4	12.25	19.6	6.62	18.38	16.0	10	19.60
405T		13.75						
404TS	36.4	12.25	19.6	6.62	18.38	16.0	10	19.60
405TS		13.75						
444T	45.6	14.5	21.8	7.5	19.63	18.0	11	21.80
445T		16.5						
444TS	41.8	14.5	21.8	7.5	19.63	18.0	11	21.80
445TS		16.5						
447T	49	20	21.8	7.5	19.63	18.0	11	22.00
447TS	45.3	20	21.8	7.5	19.63	18.0	11	22.00
449T	54	25	21.8	7.5	22	18.0	11	22.00
449TS	50.3	25	21.8	7.5	22	18.0	11	22.00
S449LS ³	63.6	25	24.6	7.5	23	18.0	11	23.30
S449LS ⁴	66.7	25	24.6	7.5	23	18.0	11	23.30
S449SS ³	59.8	25	24.6	7.5	23	18.0	11	23.30
S449SS ⁴	63.2	25	24.6	7.5	23	18.0	11	23.30

Shaft Dimensions

Frame	N-W ²	U	ENa	ENb	ENc	Keyseat		
						R	S	ES
364T - 365T	5.88	2.375	30	36	7/16"-14NC	2.02	0.625	4.25
364TS - 365TS	3.75	1.875	30	36	7/16"-14NC	1.59	0.500	2
404T - 405T	7.25	2.875	30	36	7/16"-14NC	2.45	0.750	5.63
404TS - 405TS	4.25	2.125	30	36	7/16"-14NC	1.85	0.500	2.75
444T - 449T	8.5	3.375	37	48	5/8"-11NC	2.88	0.875	6.88
444TS - 449TS	4.75	2.375	37	48	5/8"-11NC	2.02	0.625	3
S449LS	9.12	3.625	37	48	5/8"-11NC	3.134	0.875	7.5
S449SS	5.25	2.625	37	48	5/8"-11NC	2.275	0.625	3.5

C-Face

Frame	BA ¹	AH	AJ	AK	BD	BF #	BF
364/5TC	6.35	5.63	11.00	12.5	12.75	8	5/8"-11NC
364/5TSC	6.35	3.5	11.00	12.5	12.75	8	5/8"-11NC
404/5TC	7.1	7	11.00	12.5	15.50	8	5/8"-11NC
404/5TSC	7.38	4	11.00	12.5	15.50	8	5/8"-11NC
444/5TC	7.9	8.25	14.00	16	18.00	8	5/8"-11NC
444/5TSC	8.25	4.5	14.00	16	18.00	8	5/8"-11NC
447/9TC	7.96	8.25	14.00	16	18.00	8	5/8"-11NC
447/9TSC	8.25	4.5	14.00	16	18.00	8	5/8"-11NC
S449LSC	7.95	8.25	14.00	16	18.00	8	5/8"-11NC
S449SSC	8.16	4.5	14.00	16	18.00	8	5/8"-11NC

D-Flange

Frame	BA ¹	AH	AJ	AK	BD	BF #	BF
364/5TD	6.75	5.88	16.0	14.0	18.00	4	0.81
364/5TSD	6.75	3.75	16.0	14.0	18.00	4	0.81
404/5TD	6.73	7.25	20	18.0	22.00	8	0.81
404/5TSD	6.73	4.25	20	18.0	22.00	8	0.81
444/5TD	8.38	8.50	20	18.0	22.00	8	0.81
444/5TSD	8.38	4.75	20	18.0	22.00	8	0.81
447/9TD	8.38	8.50	20	18.0	22.00	8	0.81
447/9TSD	8.38	4.75	20	18.0	22.00	8	0.81
S449LSD	7.95	7.95	20	18.0	22.00	8	0.81
S449SSD	8.16	8.16	20	18.0	22.00	8	66

INPRO Seals

Frame	Reduction in usable shaft
140T	0.13
180T	0.13
210T	0.21
250T	0.17
280T	0.16
280TS	0.15
320T	0.17
320TS	0.17
360T	0.20
360TS	0.19
400T	0.13
400TS	0.13
440T	0.13
440TS	0.13
S449LS	0.22
S449SS	0.10

1. Not according to NEMA

2. Usable shaft length will be reduced by seal. See INPRO Seals table for reduction in usable shaft

3. 6 & 8 pole

4. 2 & 4 pole

Dimension in Inches; Typical dimensions data, not guaranteed.

Note: See Technical Notes for drip cover and accessory dimensions

Note: D-Flange may change standard "C" dimension

5.1.2.7. XP100, XP100 ID1- 140 – 320 Frame

140-320 Frame Foot Mount

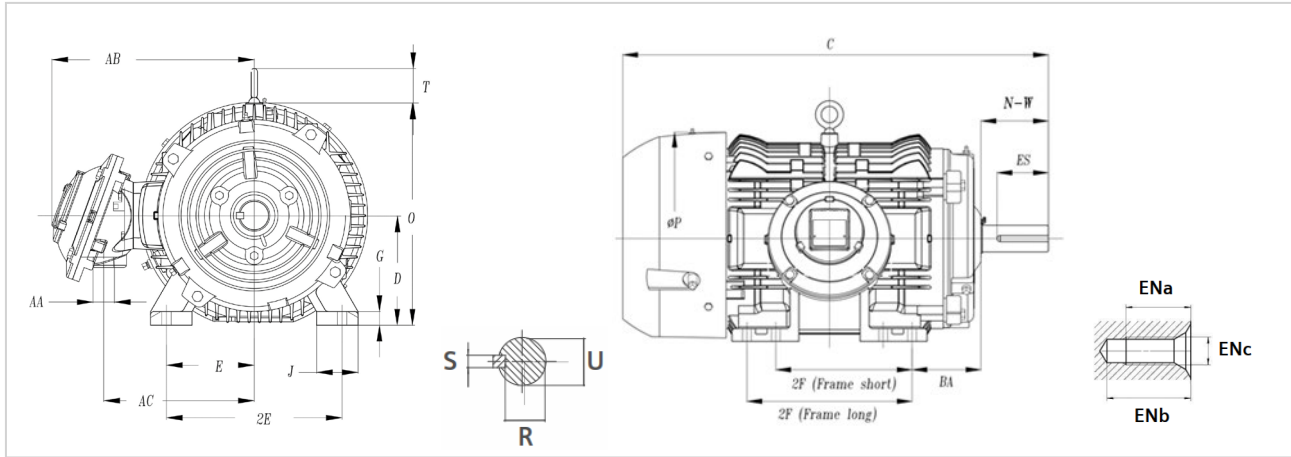

C-Face

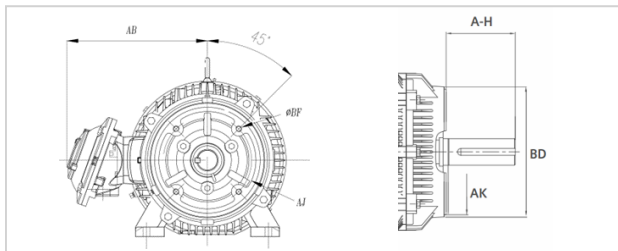

D-Flange

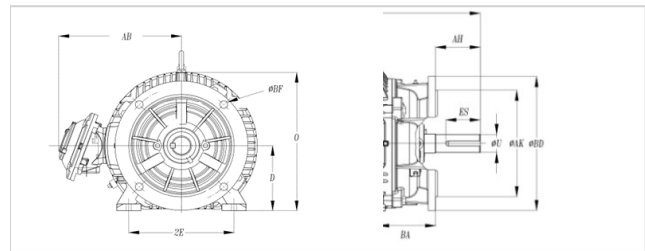

JP Shaft

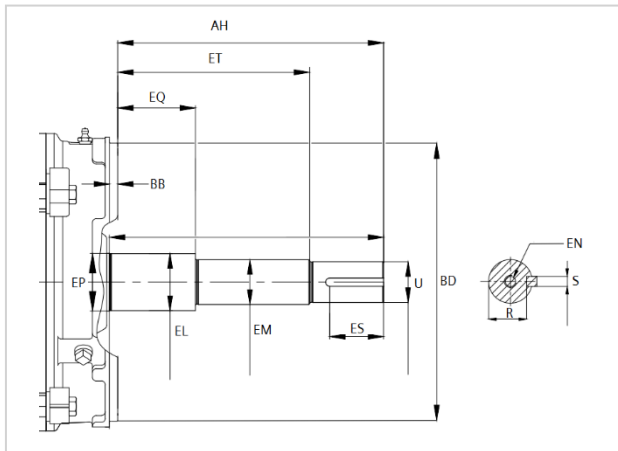

Dimension in Inches; Typical dimensions data, not guaranteed

Note: See Technical Notes for drip cover and accessory dimensions

Frame Dimensions

Frame	C	2F	P	BA	AB	2E	D	O
143T		4.0						
145T	15.27	5.0	8.2	2.25	8.75	5.5	3.5	9.19
182T		4.5						
184T	16.87	5.5	9.6	2.75	9.3	7.5	4.5	9.34
213T		5.5						
215T	19.97	7.0	10.7	3.5	10.54	8.5	5.25	10.68
254T		8.25						
256T	25.77	10.0	12.9	4.25	11.52	10.0	6.25	12.67
284T		9.5						
286T	29.40	11.0	15.8	4.75	12.85	11.0	7	14.85
284TS		9.5						
286TS	28.03	11.0	15.8	4.75	12.85	11.0	7	14.85
324T		10.5						
326T	32.08	12.0	17.7	5.25	17.35	12.5	8	16.69
324TS		10.5						
326TS	30.58	12.0	17.7	5.25	17.35	12.5	8	16.69

Shaft Dimensions

Frame	N-W	U	ENa	ENb	ENc	Keyseat		
						R	S	ES
143T-145T	2.25	0.875	–	–	–	0.771	0.188	1.41
182T-184T	2.75	1.125	–	–	–	0.986	0.250	1.81
213T-215T	3.38	1.375	–	–	–	1.201	0.312	2.44
254T-256T	4	1.625	–	–	–	1.416	0.375	2.91
284T-286T	4.63	1.875	28	34	7/16"-14NC	1.59	0.500	3.25
284TS-286TS	3.25	1.625	28	34	7/16"-14NC	1.42	0.375	1.88
324T-324TS	5.25	2.125	28	34	7/16"-14NC	1.85	0.500	3.88
324TS-326TS	3.75	1.875	28	34	7/16"-14NC	1.59	0.500	2

C-Face

Frame	BA ¹	AH	AJ	AK	BD	BF #	BF
143/5TC	2.25	2.12	4.5	5.875	6.6	4	3/8-16NC
182/4TC	2.75	2.62	8.50	7.25	8.90	4	1/2-13NC
213/5TC	3.5	3.12	8.50	7.25	8.90	4	1/2-13NC
254/6TC	4.23	3.75	8.50	7.25	9.29	4	1/2-13NC
284/6TC	4.75	4.38	9.00	10.5	11.25	4	1/2"-13NC
284/6TSC	4.75	3	9.00	10.5	11.25	4	1/2"-13NC
324/6TC	5.25	5	11.00	12.5	14.00	4	5/8"-11NC
324/6TSC	5.25	3.5	11.00	12.5	14.00	4	5/8"-11NC

D-Flange

Frame	BA ¹	AH	AJ	AK	BD	BF #	BF
284/6TD	5.88	4.38	12.5	11.0	13.88	4	0.81
284/6TSD	5.88	3.00	12.5	11.0	13.88	4	0.81
324/6TD	6.24	5.00	16	14.0	17.87	4	0.81
324/6TSD	6.24	3.50	16	14.0	17.87	4	0.81

JP Shaft

Frame	Shaft							Keyset					Flange		
	AH	ET	EQ	U	EM	EL	EP	EN	R	S	ES	AJ	BD	BF#	BF
182/4JP	7.342	5.945	1.575	0.875	1.000	1.250	1.378	3/8"-16NC	0.771	0.188	1.650	5.875	6.580	4	3/8"-16NC
213/5JP	8.150	5.890	2.380	1.250	1.370	1.750	1.770	1/2"-13NC	1.112	0.252	1.650	7.250	8.500	4	1/2"-13NC

1. Not according to NEMA

Dimension in Inches; Typical dimensions data, not guaranteed

Note: See Technical Notes for drip cover and accessory dimensions

Note: D-Flange may change standard "C" dimension

5.1.2.8. XP100, XP100 ID1 – 360 – 440 Frame

360-440 Frame Foot Mount

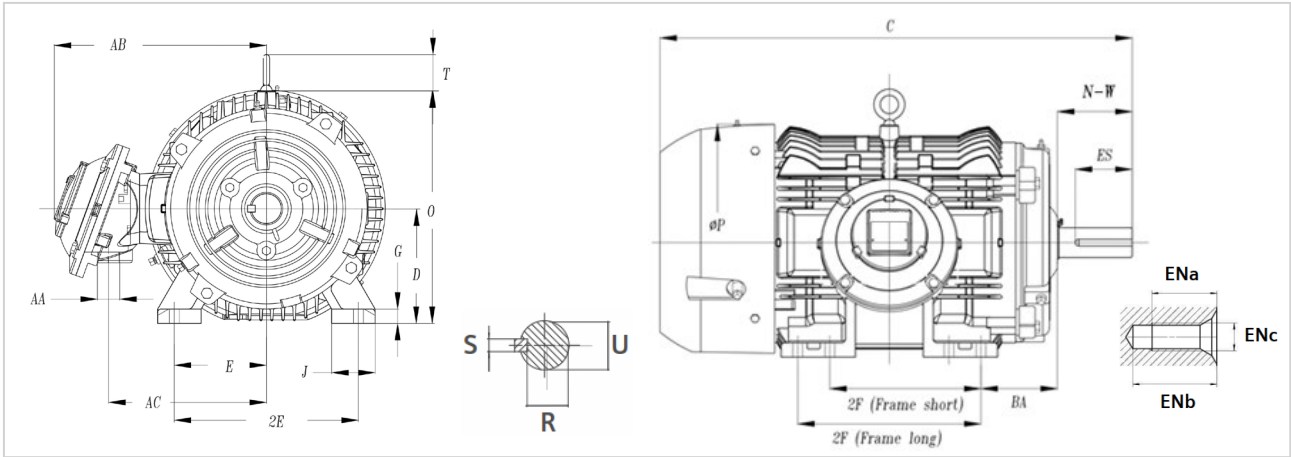

C-Face

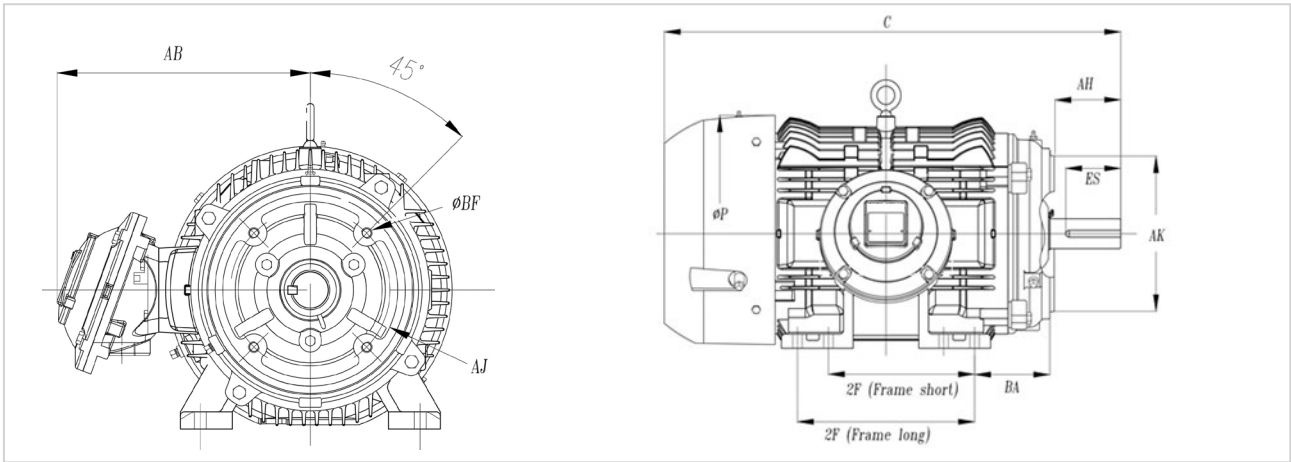

D-Flange

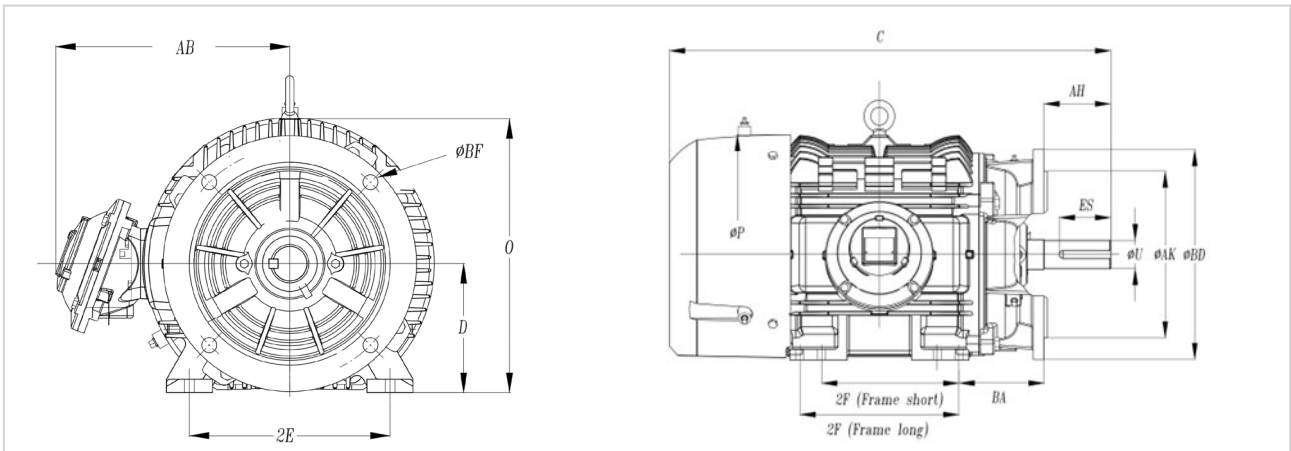

Dimension in Inches; Typical dimensions data, not guaranteed

Note: See Technical Notes for drip cover and accessory dimensions

Frame Dimensions

Frame	C	2F	P	BA	AB	2E	D	O
364T	35.28	11.25	19.6	5.88	18.18	14.0	9	18.65
365T		12.25						
364TS	33.16	11.3	19.6	5.88	18.18	14.0	9	18.65
365TS		12.25						
404T	39.52	12.25	19.6	6.62	20.34	16.0	10	19.61
405T		13.75						
404TS	36.52	12.25	19.6	6.62	20.34	16.0	10	19.61
405TS		13.75						
444T	45.58	14.5	21.7	7.5	21.59	18.0	11	21.98
445T		16.5						
444TS	41.83	14.50	21.7	7.5	21.59	18.0	11	21.98
445TS		16.5						
447T	49.08	20.00	21.7	7.5	21.59	18.0	11	21.98
447TS	45.33	20.00	21.7	7.5	21.59	18.0	11	21.98
449T	54.08	25.00	21.7	7.5	23.46	18.0	11	21.98
449TS	50.33	25.00	21.7	7.5	23.46	18.0	11	21.98

Shaft Dimensions

Frame	N-W	U	ENa	ENb	ENC	Keyseat		
						R	S	ES
364T - 365T	5.88	2.375	30	36	7/16"-14NC	2.02	0.625	4.25
364TS - 365TS	3.75	1.875	30	36	7/16"-14NC	1.59	0.500	2
404T - 405T	7.25	2.875	30	36	7/16"-14NC	2.45	0.750	5.63
404TS - 405TS	4.25	2.125	30	36	7/16"-14NC	1.85	0.500	2.75
444T - 449T	8.5	3.375	37	48	5/8"-11NC	2.88	0.875	6.88
444TS - 449TS	4.75	2.375	37	48	5/8"-11NC	2.02	0.625	3

C-Face

Frame	BA ¹	AH	AJ	AK	BD	BF #	BF
364/5TC	6.62	5.62	11.00	12.5	14	8	5/8"-11NC
364/5TSC	6.62	3.5	11.00	12.5	14.00	8	5/8"-11NC
404/5TC	6.62	7	11.00	12.5	15.50	8	5/8"-11NC
404/5TSC	6.62	4	11.00	12.5	15.50	8	5/8"-11NC
444/5TC	7.5	8.25	14.00	16	18.00	8	5/8"-11NC
444/5TSC	7.5	4.5	14.00	16	18.00	8	5/8"-11NC
447/9TC	7.5	8.25	14.00	16	18.00	8	5/8"-11NC
447/9TSC	7.5	4.5	14.00	16	18.00	8	5/8"-11NC

D-Flange

Frame	BA ¹	AH	AJ	AK	BD	BF #	BF
364/5TD	6.75	5.62	16	14	18	4	0.81
364/5TSD	6.75	3.5	16	14	18	4	0.81
404/5TD	7.18	7	16	14	22	8	0.81
404/5TSD	7.18	4	16	14	22	8	0.81
444/5TD	8.38	8.5	14	18.0	22.00	8	0.81
444/5TSD	8.38	4.50	14	18.0	22.00	8	0.81
447/9TD	8.38	8.5	14	18.0	22.00	8	0.81
447/9TSD	8.38	4.50	14	18.0	22.00	8	0.81

1. Not according to NEMA

Dimension in Inches; Typical dimensions data, not guaranteed.

Note: See Technical Notes for drip cover and accessory dimensions

Note: D-Flange may change standard “C” dimension

5.1.2.9. 140-320 Frame Foot Mount

140-320 Frame Foot Mount

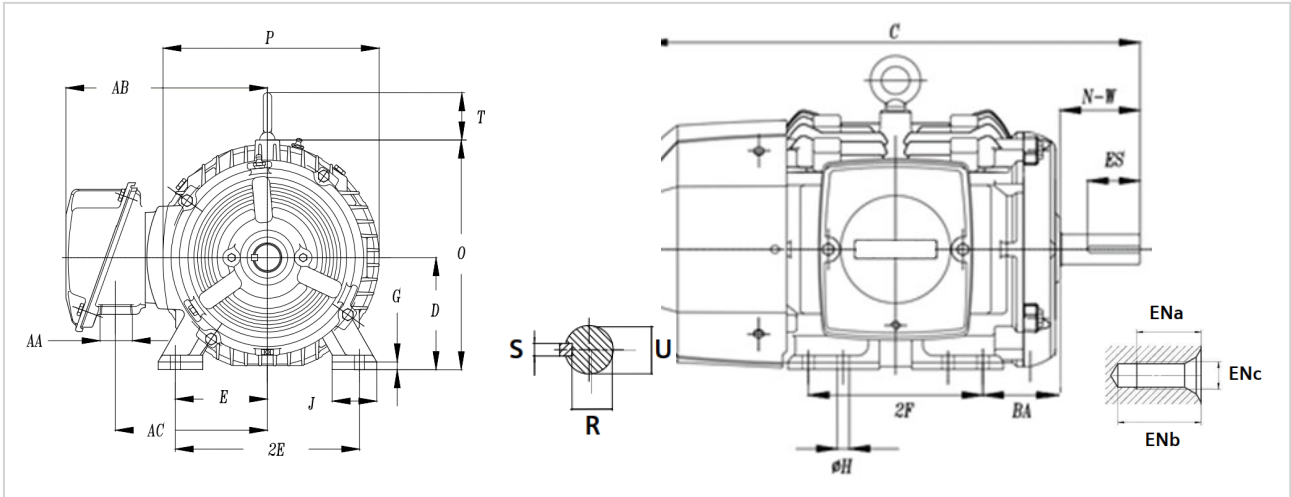

C-Face

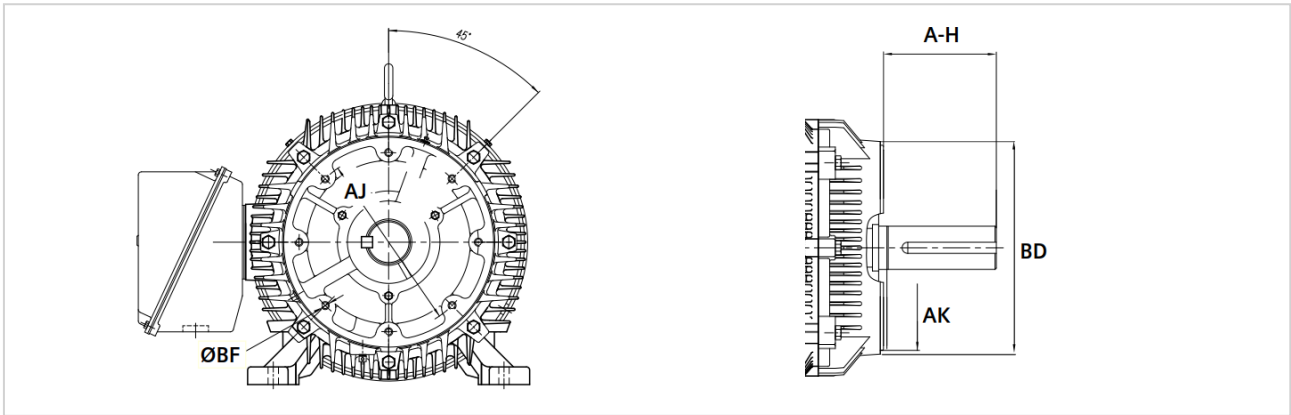

D-Flange

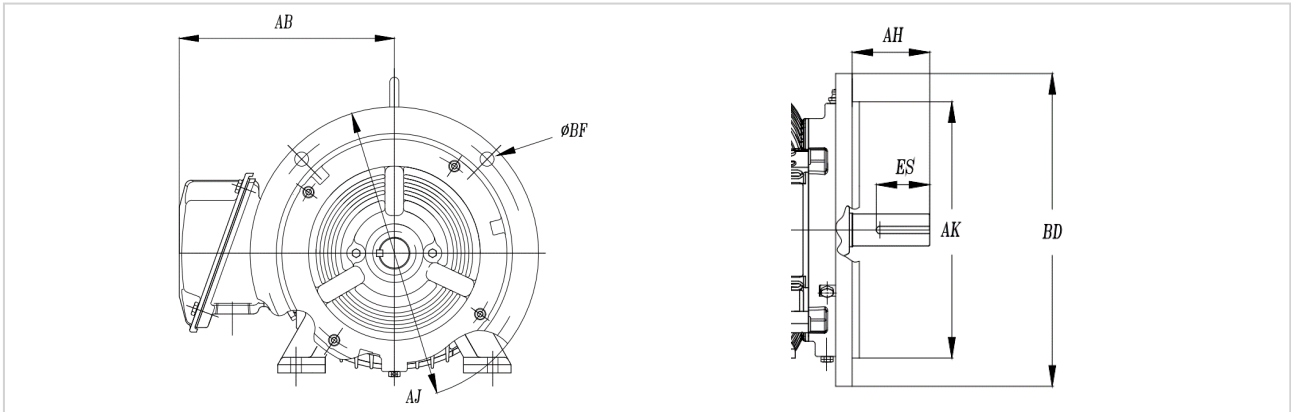

Dimension in Inches; Typical dimensions data, not guaranteed.

Note: See Technical Notes for drip cover and accessory dimensions

Frame Dimensions

Frame	C	2F	P	BA	AB	2E	D	O
143T		4.0						
145T	14.37	5.0	7.6	2.25	7	5.5	3.5	7.28
182T		4.5						
184T	16.68	5.5	8.7	2.75	6.94	7.5	4.5	8.87
213T		5.5						
215T	20.65	7.0	10.3	3.5	8.27	8.5	5.25	10.41
254T		8.25						
256T	26.16	10.0	12.4	4.25	9.35	10.0	6.25	12.43
284T		9.5						
286T	27.40	11.0	15.5	13.4	4.75	11.0	7	14.19
284TS		9.5						
286TS	26.00	11.0	15.5	13.4	4.75	11.0	7	14.19
324T		10.5						
326T	32.00	12.0	17.1	15.75	5.25	12.5	8	15.94
324TS		10.5						
326TS	30.00	12.0	17.1	15.75	5.25	12.5	8	15.94

Shaft Dimensions

Frame	N-W	U	ENa	ENb	ENc	Keyseat		
						R	S	ES
143T-145T	2.25	0.875	–	–	–	0.771	0.188	1.41
182T-184T	2.75	1.125	–	–	–	0.986	0.250	1.81
213T-215T	3.38	1.375	–	–	–	1.201	0.312	2.44
254T-256T	4	1.625	–	–	–	1.416	0.375	2.91
284T-286T	4.63	1.875	28	34	7/16"-14NC	1.59	0.500	3.25
284TS-286TS	3.25	1.625	28	34	7/16"-14NC	1.42	0.375	1.88
324T-324TS	5.25	2.125	28	34	7/16"-14NC	1.85	0.500	3.88
324TS-326TS	3.75	1.875	28	34	7/16"-14NC	1.59	0.500	2

C-Face

Frame	BA ¹	AH	AJ	AK	BD	BF #	BF
143/5TC	2.25	2.12	5.875	4.5	6.6	4	3/8"-16NC
182/4TC	2.75	2.62	7.25	8.5*	8.90	4	1/2"-13NC
213/5TC	3.5	3.12	7.25	8.5	8.90	4	1/2"-13NC
254/6TC	4.25	3.75	7.25	8.5	9.30	4	1/2"-13NC
284/6TC	4.75	4.38	9.00	10.5	10.75	4	1/2"-13NC
284/6TSC	4.75	3	9.00	10.5	10.75	4	1/2"-13NC
324/6TC	5.25	5	11.00	12.5	12.75	4	5/8"-11NC
324/6TSC	5.25	3.5	11.00	12.5	12.75	4	5/8"-11NC

D-Flange

Frame	BA ¹	AH	AJ	AK	BD	BF #	BF
143/5TD	2.25	2.25	10.0	9.0	10.90	4	0.53
182/4TD	2.75	2.75	10.0	9.0	11.00	4	0.53
213/5TD	3.5	3.38	10	9.0	10.90	4	0.53
254/6TD	4.25	4.00	12.5	11.0	13.90	4	0.81
284/6TD	5.88	4.62	12.5	11.0	13.88	4	0.81
284/6TSD	5.88	3.25	12.5	11.0	13.88	4	0.81
324/6TD	6.25	5.25	16	14.0	17.88	4	0.81
324/6TSD	6.25	3.75	16	14.0	17.88	4	0.81

1. Not according to NEMA

Dimension in Inches; Typical dimensions data, not guaranteed.

Note: See Technical Notes for drip cover and accessory dimensions

Note: D-Flange may change standard “C” dimension

5.1.2.10. SD10 MS – 360 – 440 Frame

360-440 Frame Foot Mount

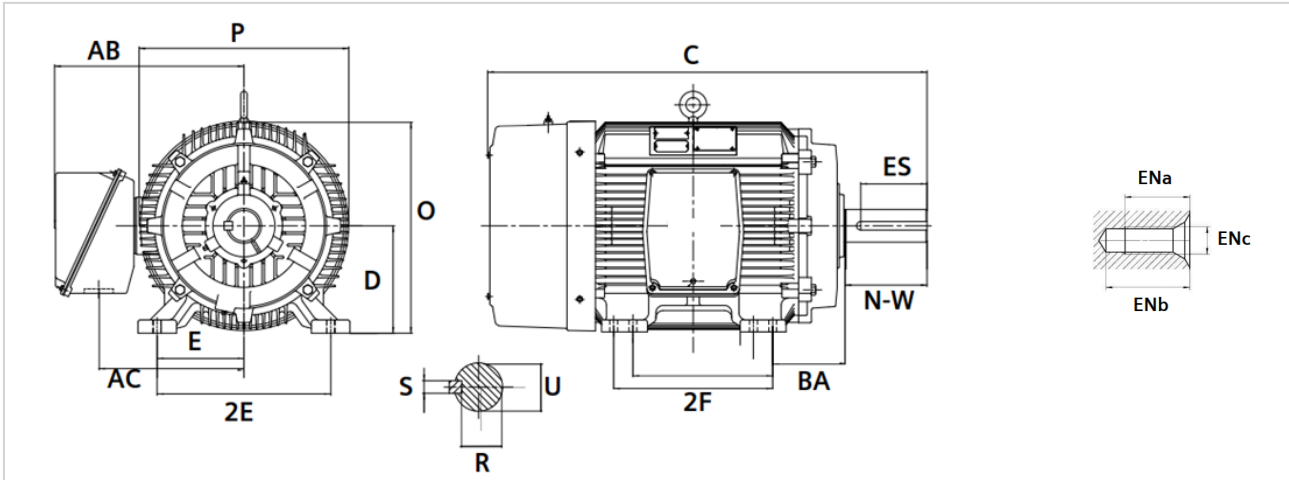

C-Face

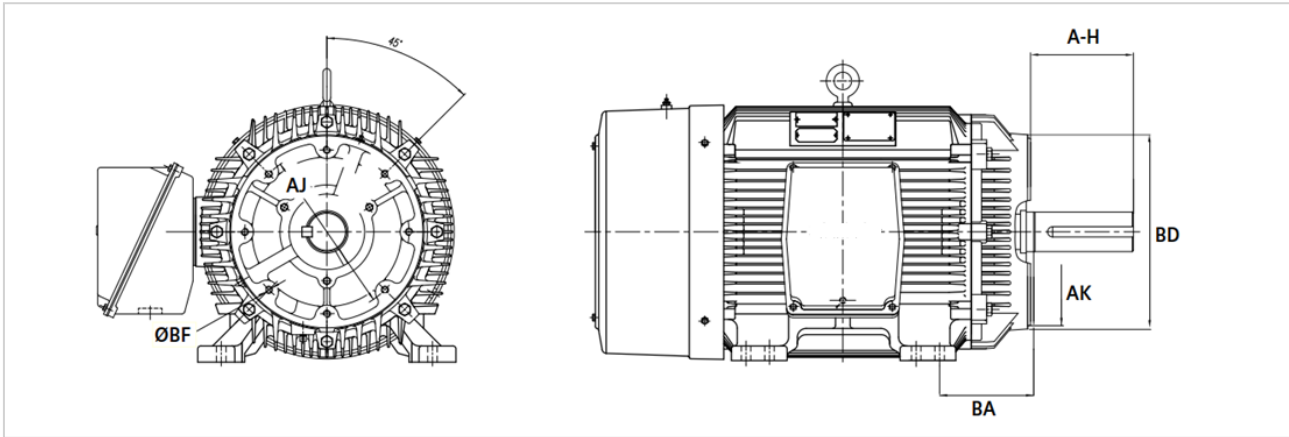

D-Flange

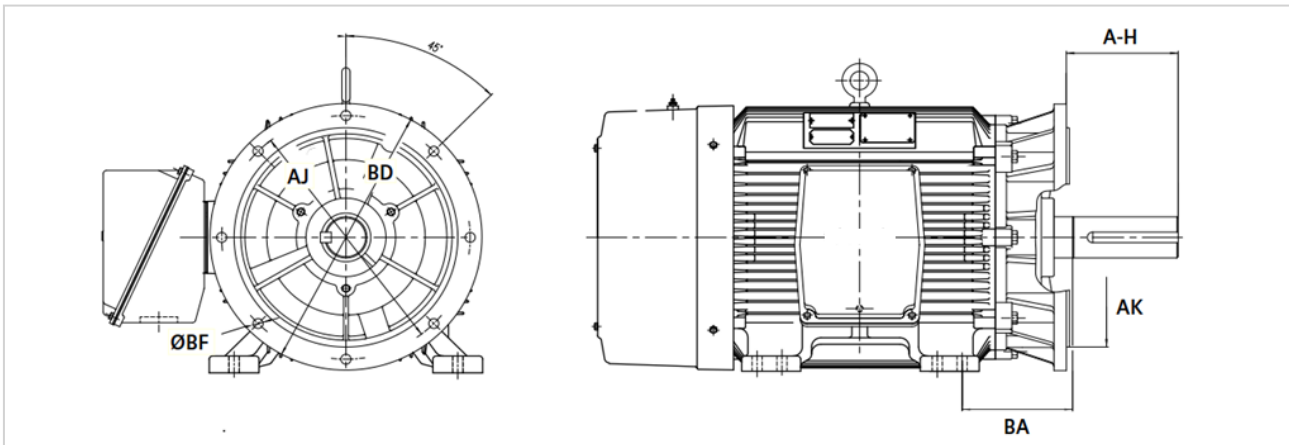

Dimension in Inches; Typical dimensions data, not guaranteed.

Note: See Technical Notes for drip cover and accessory dimensions

Frame Dimensions

Frame	C	2F	P	AB	BA	2E	D	O
364T	34.20	11.25	18.5	17.69	5.88	14.0	9	17.81
365T		12.25						
364TS	32.10	11.3	18.5	17.69	5.88	14.0	9	17.81
365TS		12.25						
404T	39.50	12.25	19.6	17.5	6.62	16.0	10	19.90
405T		13.75						
404TS	36.40	12.25	19.6	18.38	6.62	16.0	10	19.60
405TS		13.75						
444T	45.60	14.50	21.7	19.94	7.5	18.0	11	21.90
445T		16.50						
444TS	41.80	14.50	21.7	19.94	7.5	18.0	11	21.90
445TS		16.50						
447T	49.10	20.00	21.8	19.94	7.5	18.0	11	21.90
447TS	45.40	20.00	21.8	19.94	7.5	18.0	11	21.90
449T	54.10	25.00	21.8	22	7.5	18.0	11	21.90
449TS	50.30	25.00	21.8	22	7.5	18.0	11	21.90

Shaft Dimensions

Frame	N-W	U	ENa	ENb	ENC	Keyseat		
						R	S	ES
364T - 365T	5.88	2.375	30	36	7/16"-14NC	2.02	0.625	4.25
364TS - 365TS	3.75	1.875	30	36	7/16"-14NC	1.59	0.500	2
404T - 405T	7.25	2.875	30	36	7/16"-14NC	2.45	0.750	5.63
404TS - 405TS	4.25	2.125	30	36	7/16"-14NC	1.85	0.500	2.75
444T - 449T	8.5	3.375	37	48	5/8"-11NC	2.88	0.875	6.88
444TS - 449TS	4.75	2.375	37	48	5/8"-11NC	2.02	0.625	3

C-Face

Frame	BA ¹	AH	AJ	AK	BD	BF #	BF
364/5TC	5.88	5.62	11.00	12.5	12.75	8	5/8"-11NC
364/5TSC	5.88	3.5	11.00	12.5	12.75	8	5/8"-11NC
404/5TC	6.63	7	11.00	12.5	13.50	8	5/8"-11NC
404/5TSC	6.63	4	11.00	12.5	13.50	8	5/8"-11NC
444/5TC	7.5	8.25	14.00	16	16.62	8	5/8"-11NC
444/5TSC	7.5	4.5	14.00	16	16.62	8	5/8"-11NC
447/9TC	7.5	8.25	14.00	16	16.62	8	5/8"-11NC
447/9TSC	7.5	4.5	14.00	16	16.62	8	5/8"-11NC

D-Flange

Frame	BA ¹	AH	AJ	AK	BD	BF #	BF
364/5TD	6.75	5.88	16.0	14.0	17.88	4	0.81
364/5TSD	6.75	3.75	16.0	14.0	17.88	4	0.81
404/5TD	7.12	7.25	20	18.0	21.88	8	0.81
404/5TSD	7.12	4.25	20	18.0	21.88	8	0.81
444/5TD	8.38	8.50	20	18.0	21.88	8	0.81
444/5TSD	8.38	4.75	20	18.0	21.88	8	0.81
447/9TD	8.38	8.50	20	18.0	21.88	8	0.81
447/9TSD	8.38	4.75	20	18.0	21.88	8	0.81

1. Not according to NEMA

Dimension in Inches; Typical dimensions data, not guaranteed.

Note: See Technical Notes for drip cover and accessory dimensions

Note: D-Flange may change standard “C” dimension

5.1.2.11. HP100, LP100 – 180 – 440 Frame

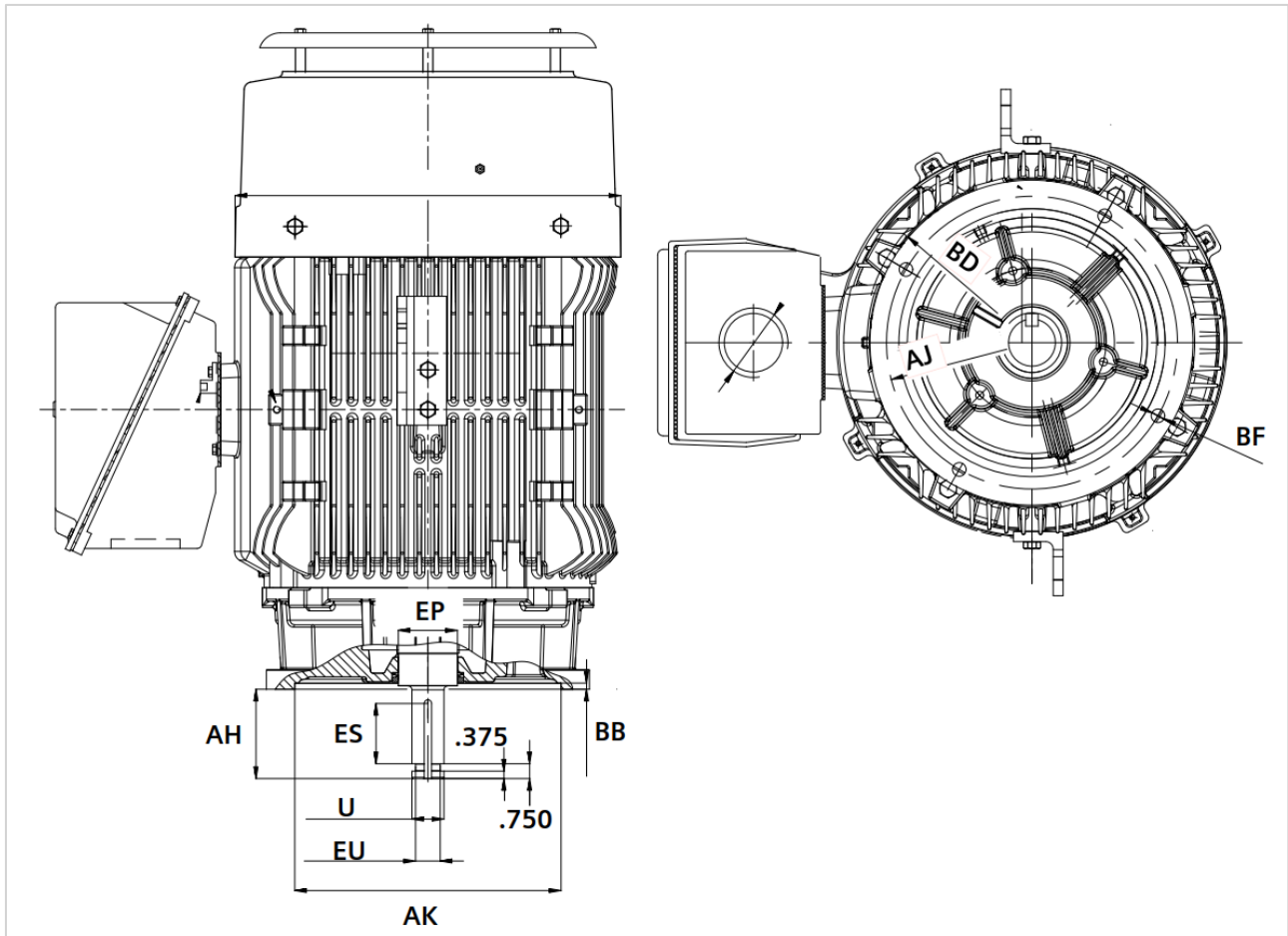

Dimension in Inches; Typical dimensions data, not guaranteed

Frame	U	EU	EP	BD	AH	AJ	AK	BF	Keyseat		
									R	S	ES
182/4LP	1.125	0.875	1.18	10.0	2.76	9.125	8.25	0.438	0.986	0.250	2.03
213/5LP	1.625	1.250	1.77	10.0	2.76	9.125	8.25	0.438	1.416	0.375	2.03
254/6LP	1.625	1.250	1.77	10.0	2.80	9.125	8.25	0.438	1.416	0.375	2.03
284/6LP	2.125	1.750	2.36	10.0	4.5	9.125	8.25	0.438	1.845	0.500	3.03
284/6LPH	2.125	1.750	2.36	16.5	4.5	14.75	13.50	0.688	1.845	0.500	3.03
324/6LP	2.125	1.750	2.36	16.5	4.5	14.75	13.50	0.688	1.845	0.500	3.03
364/5LP	2.125	1.750	3.00	16.5	4.5	14.75	13.50	0.688	1.845	0.500	3.03
404/5LP	2.125	1.750	3.00	16.5	4.5	14.75	13.50	0.688	1.845	0.500	3.00
444/5LP	2.125	1.750	3.00	16.5	4.5	14.75	13.50	0.688	1.845	0.500	3.00
447/9LP	2.125	1.750	3.00	16.5	4.5	14.75	13.50	0.688	1.845	0.500	3.00

Frame	U	EU	EP	BD	AH	AJ	AK	BF	Keyseat		
									R	S	ES
182/4HP	1.125	0.875	1.18	10.0	2.76	9.125	8.25	0.438	0.986	0.250	2.03
213/5HP	1.125	0.874	1.77	10.0	2.76	9.125	8.25	0.438	0.896	0.250	2.03
254/6HP	1.125	0.875	1.77	10.0	2.76	9.125	8.25	0.438	0.986	0.250	2.03
284/6HP	1.125	0.875	1.97	10.0	2.75	9.125	8.3	0.438	0.986	0.250	1.35
324/6HP	1.625	1.250	2.36	16.5	4.5	14.75	13.5	0.688	1.416	0.375	3.09
364/5HP	1.250	1.625	3.00	16.5	4.5	14.75	13.5	0.688	1.416	0.375	3.03
404/5HP	1.625	1.250	3.00	16.5	4.5	14.75	13.5	0.688	1.416	0.375	3.00
444/5HP	2.125	1.750	3.00	16.5	4.5	14.75	13.5	0.688	1.845	0.500	3.00
447/9HP	2.125	1.750	3.00	16.5	4.5	14.75	13.5	0.688	1.845	0.500	3.00

Dimension in Inches; Typical dimensions data, not guaranteed

5.1.3. Terminal Boxes – Schematics

5.1.3.1. SD200, SD200 841, DP200 HPS

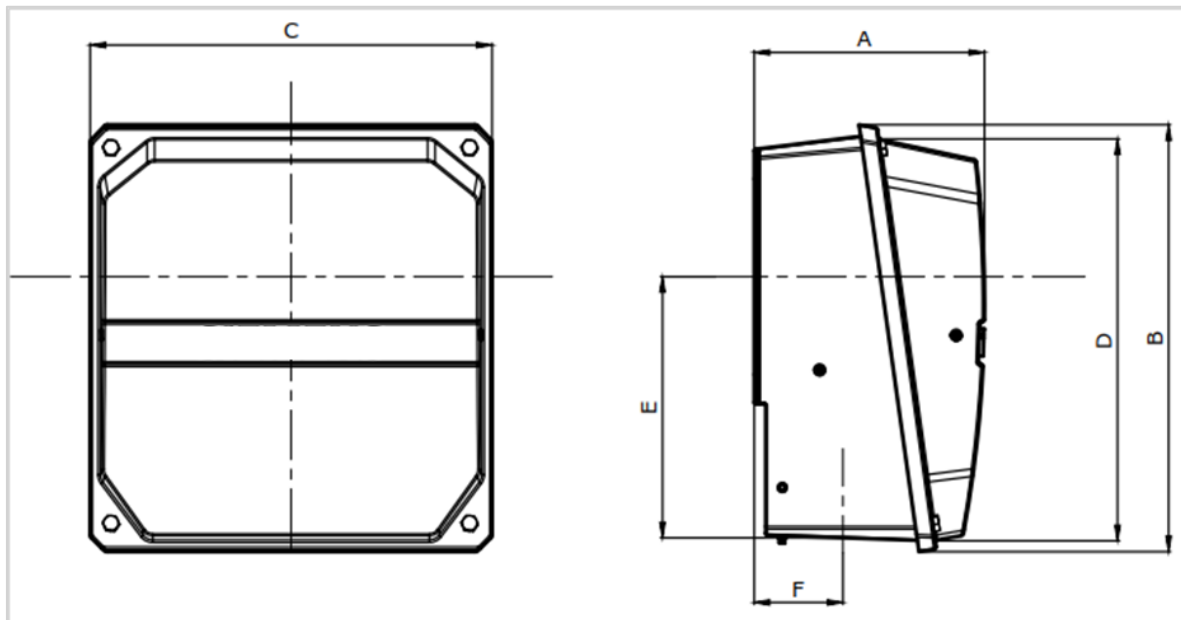
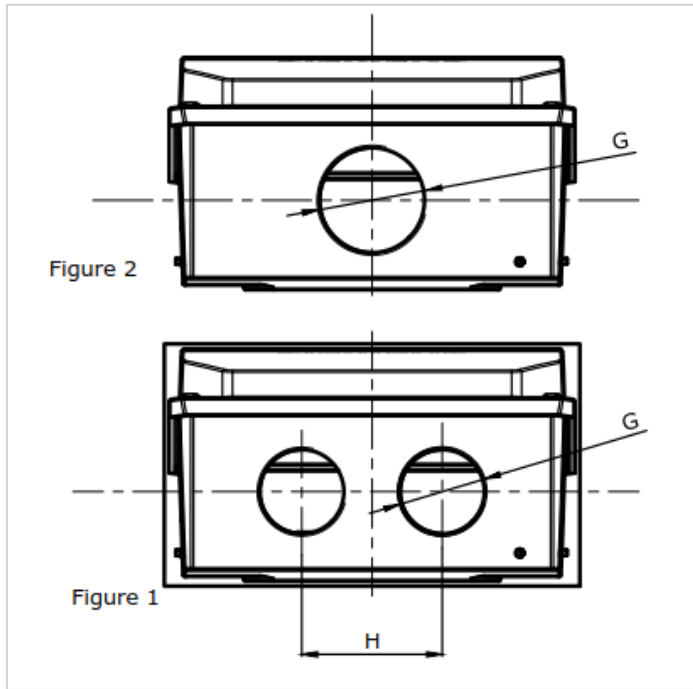

Typical dimensions data, not guaranteed

Frame	General Dimensions							Qty.	H	Figure	Approx. internal volume (in ³)	Number of cover bolts
	A	B	C	D	E	F	G					
444-447	10.15	15.31	11.02	13.86	8.59	4.43	3 - NPT	1	-	2	1066	4
444-447	10.15	15.31	11.02	13.86	8.59	4.43	2.5 - NPT	2	3.54	1	1066	4
449-L449	10.54	16.87	15.35	15.42	8.98	4.43	4 - NPT	1	-	2	1718	4
449-L449	10.54	16.87	15.35	15.42	8.98	4.43	4 - NPT	2	5.80	1	1718	4
500	11.73	21.71	20.47	20.43	13.28	4.52	4 - NPT	2	7.10	1	3480	4
500	11.73	21.71	20.47	20.43	13.28	4.52	5 - NPT	1	-	2	3480	4

Typical dimensions data, not guaranteed

5.1.3.2. GP100A, GP100

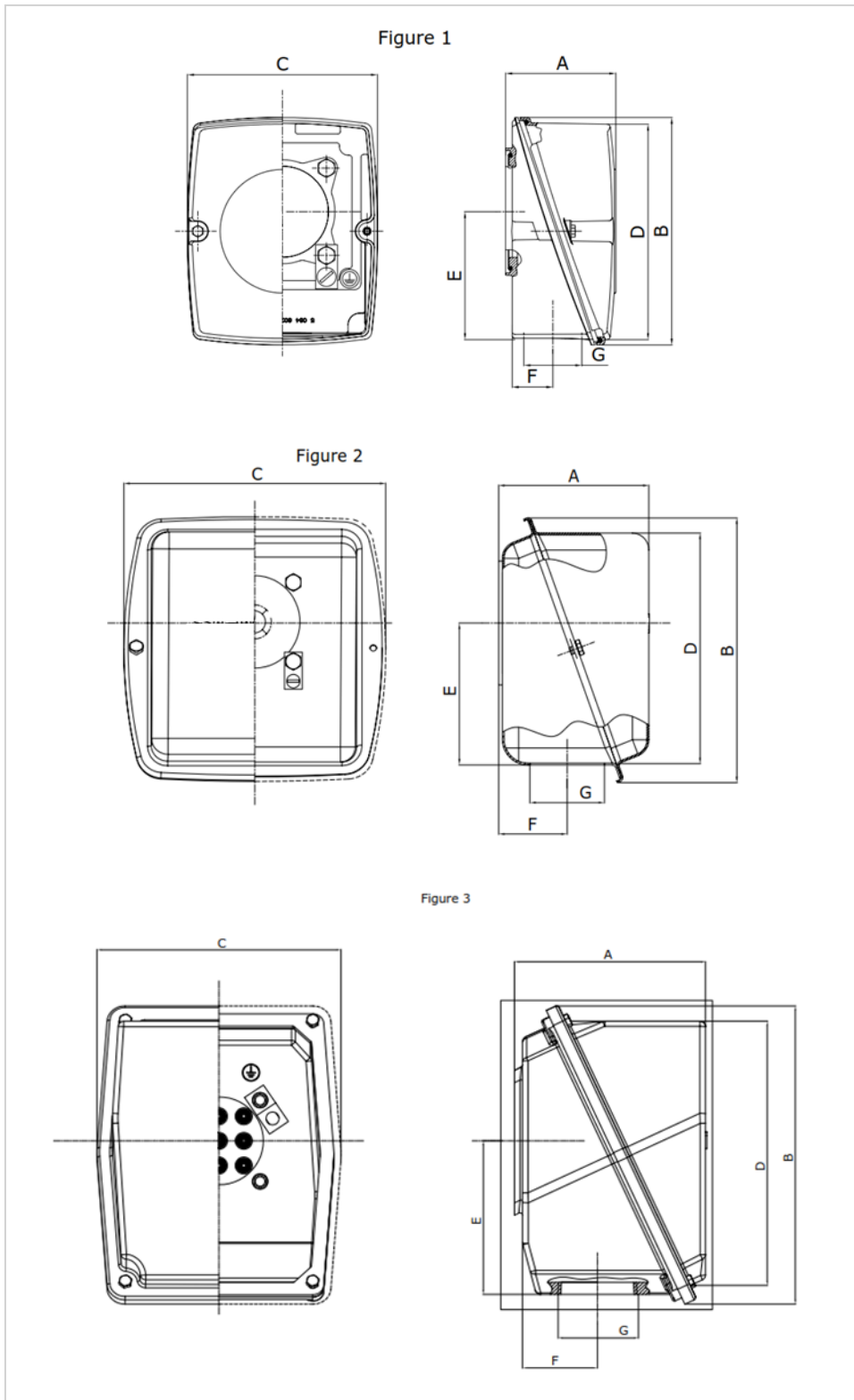

Typical dimensions data, not guaranteed

External Dimensions (in)								Vol Int approx. (in ³)	No. screws on cover	Fig	Material
Frames	A	B	C	D	EP	F	G				
140	2.79	5.31	4.41	4.98	2.69	0.95	0.75 NPT	37	2	1	Cast Aluminum
180	2.79	5.31	4.41	4.98	2.69	0.95	0.75 NPT	37	2	1	Cast Aluminum
210	3.30	6.89	5.71	6.52	3.87	1.18	1 NPT	87	2	1	Cast Aluminum
250	3.30	6.89	5.71	6.52	3.87	1.18	1.25 NPT	87	2	1	Cast Aluminum
280	5.00	8.60	8.70	7.48	4.60	2.28	2 NPT	230	2	2	Stamped Steel
320	5.00	8.60	8.70	7.48	4.60	2.28	2.5 NPT	230	2	2	Stamped Steel
360	7.44	9.94	9.69	9.69	4.72	3.10	3 NPT	465	2	2	Stamped Steel
400	7.44	9.94	9.69	9.69	4.72	3.10	3 NPT	465	2	2	Stamped Steel
440	8.60	13.59	10.99	12.03	7.00	3.37	3 NPT	748	4	3	Cast Iron

5.1.3.3. SD100, SD100 IEEE, SD10 MS, HP100, LP100

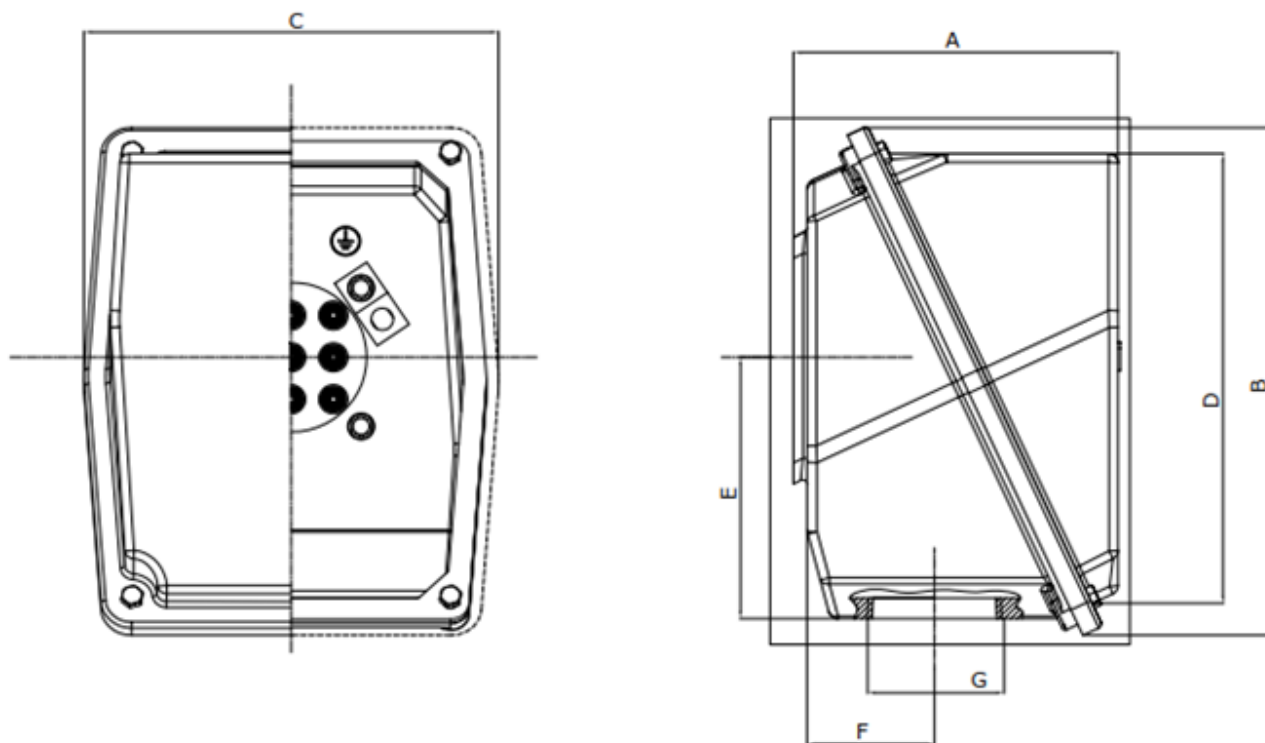

External Dimensions (in)									
Frames	A	B	C	D	EP	F	G	Vol Int approx. (in ³)	No. screws on top
140	3.23	5.98	4.96	5.46	2.28	1.18	0.75 NPT	41	4
180	3.23	5.98	4.96	5.46	2.28	1.18	0.75 NPT	41	4
210	4.24	7.11	5.94	6.42	3.43	1.69	1 NPT	86	4
250	4.24	7.11	5.94	6.42	3.43	1.69	1.25 NPT	86	4
280	6.00	8.19	7.74	8.19	4.75	2.37	1.5 NPT	222	4
320	7.05	11.07	8.92	9.90	5.50	3.00	2 NPT	400	4
360	8.60	13.59	10.99	12.03	7.00	3.37	3 NPT	748	4
400	8.60	13.59	10.99	12.03	7.00	3.37	3 NPT	748	4
444-447	8.60	13.59	10.99	12.03	7.00	3.37	3 NPT	748	4
449	10.55	16.75	14.00	15.01	8.50	5.00	3 NPT	1696	4
S449	10.55	16.75	14.00	15.01	8.50	5.00	4 NPT	1696	4

Typical dimensions data, not guaranteed

5.1.3.4. XP100, XP100 ID1

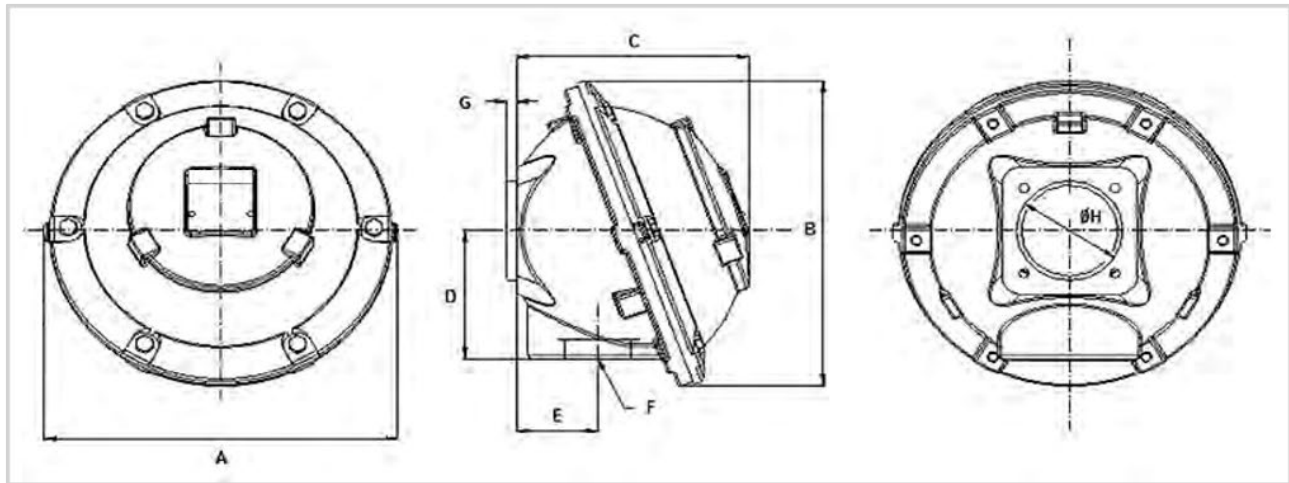

Frames	External Dimensions (in)								Vol Int approx. (in ³)	No. screws on top
	A	B	C	D	EP	F	G	H		
140	7.28	6.65	4.07	2.56	1.61	3/4"-14 NPT	0.35	2.20	39.0	4
180	7.28	6.65	4.07	2.56	1.61	3/4"-14 NPT	0.35	2.20	39.0	4
210	8.07	7.40	4.66	2.95	1.73	1"-11.5NPT	0.35	2.83	64.0	4
250	8.07	7.40	4.66	2.95	1.73	1"-11.5NPT	0.35	2.83	64.0	4
280	8.07	7.40	4.66	2.95	1.73	1.5"-11.5NPT	0.35	2.83	64.0	4
320	12.00	11.13	7.90	4.65	2.76	2"-11.5NPT	0.35	3.62	278.4	6
360	12.00	11.13	7.90	4.65	2.76	3"-8NPT	0.35	3.62	278.4	6
400	14.09	13.11	9.88	5.83	4.17	3"-8NPT	0.35	4.72	552.0	6
444/445	14.09	13.11	9.88	5.83	4.17	3"-8NPT	0.35	4.72	552.0	6
447	14.09	13.11	9.88	5.83	4.17	3"-8NPT	0.35	4.72	552.0	6
449	17.24	16.14	11.75	6.89	5.45	3"-8NPT	0.35	4.72	972.0	6

Dimension in Inches; Typical dimensions data, not guaranteed.

Note: See Technical Notes for drip cover and accessory dimensions

5.1.3.5. Auxiliary Boxes

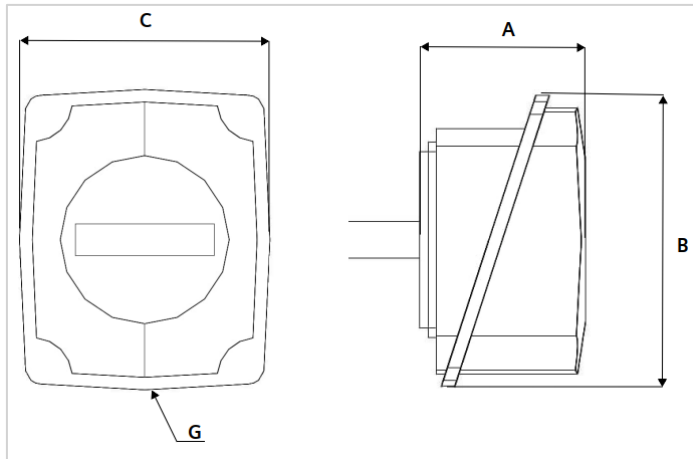

Frames	Option	External Dimensions (in)			
		A	B	C	G
320-500	Stator RTD Box	5.83	9.53	7.74	1" NPT
210-500	Cast Iron Aux Box	3.50	6.10	5.47	3/4" NPT

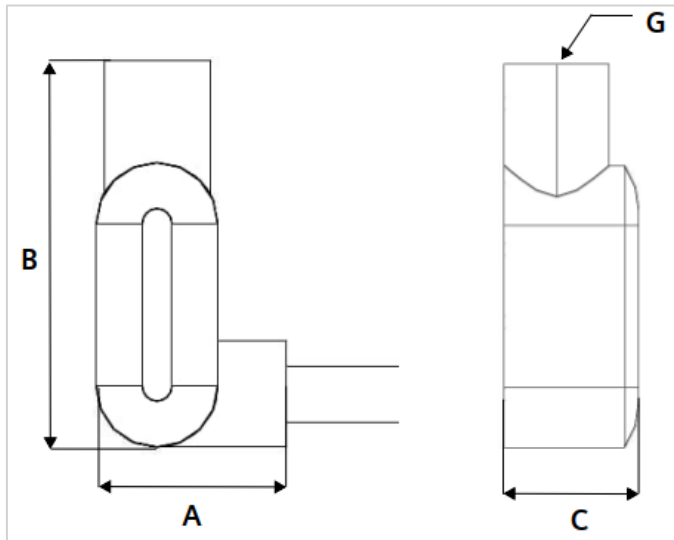

Frames	Option	External Dimensions (in)			
		A	B	C	G
140-500	Condulet Aux box	2.438	5.188	1.625	3/4" NPT

Note: Condulet may be LL, LR or LB type depending on configuration

Typical dimensions data, not guaranteed

5.1.3.6. Special Oversized Boxes

SD200 Option T11

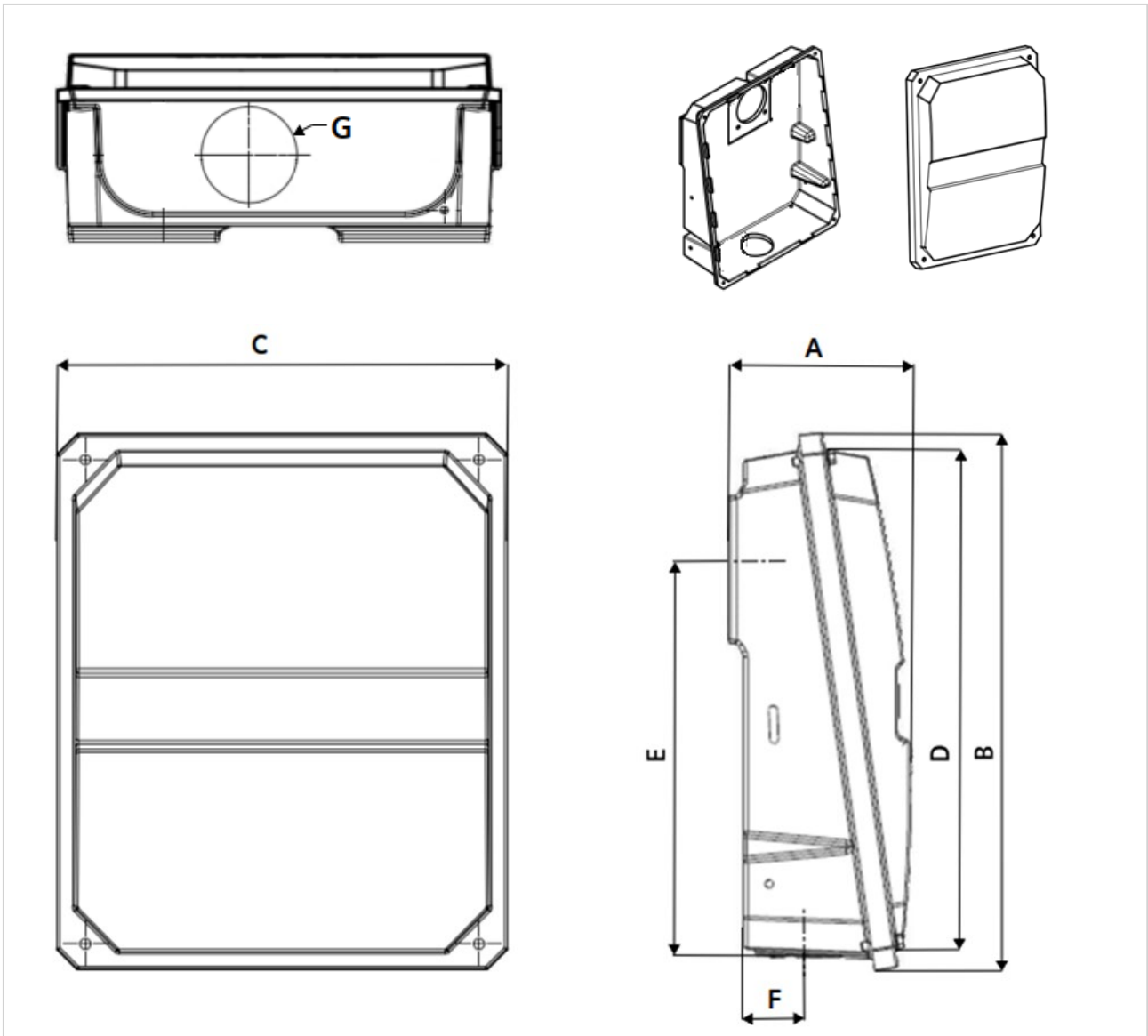

Frame	Motor Type	Option	General Dimensions							Qty.	Approx. internal volume (in ³)	Number of cover bolts
			A	B	C	D	E	F	G			
444-449	SD200	T11	9.51	24.41	20.55	22.63	17.85	3.15	4" NPT	1	2778	4

Typical dimensions data, not guaranteed

SD200 Option T03/T06

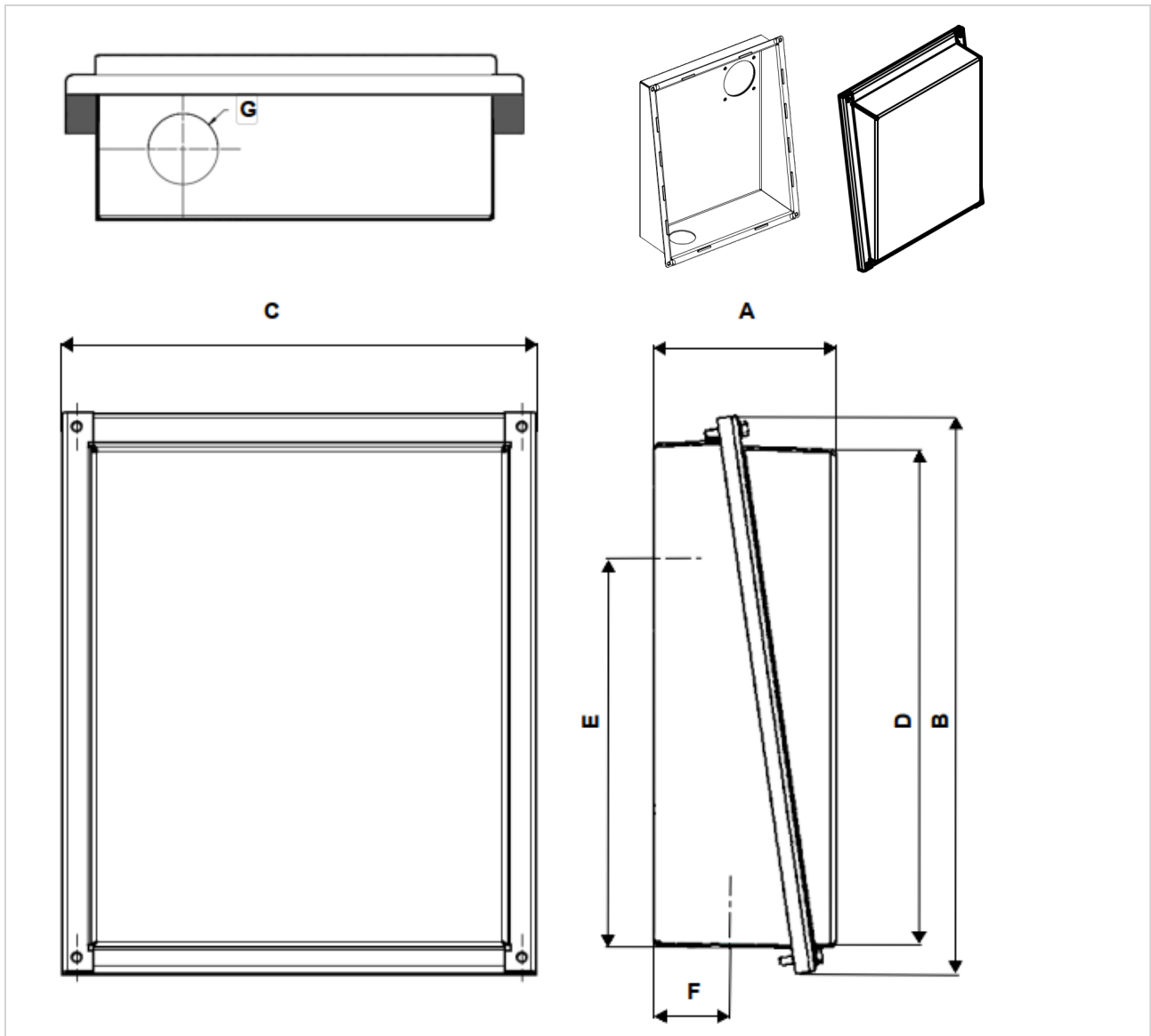

Frame	Motor Type	Option	General Dimensions							Qty.	Approx. internal volume (in ³)	Number of cover bolts
			A	B	C	D	E	F	G			
444-449	SD200	T03	7.44	24.41	20.57	21.67	16.88	3.30	3.25	1	3046	4
444-449	SD200	T06	7.44	24.41	20.57	21.67	16.88	-	-	0	3046	4

Typical dimensions data, not guaranteed

SD200 Option T04

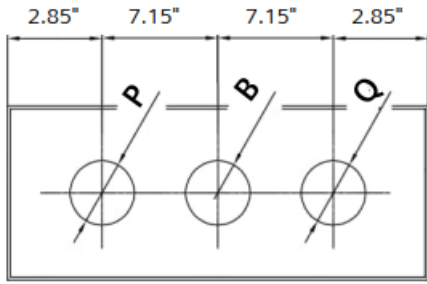

Figure 1

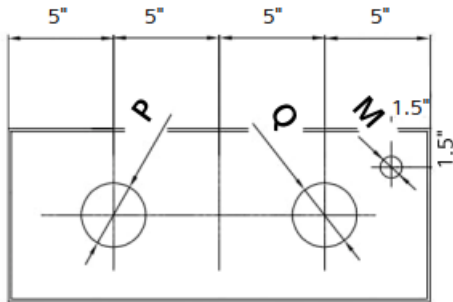
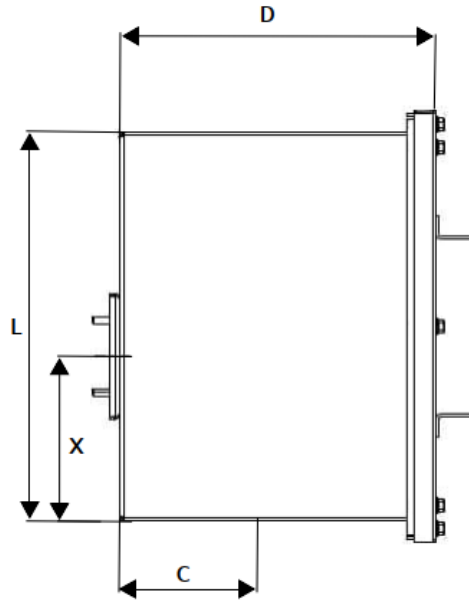
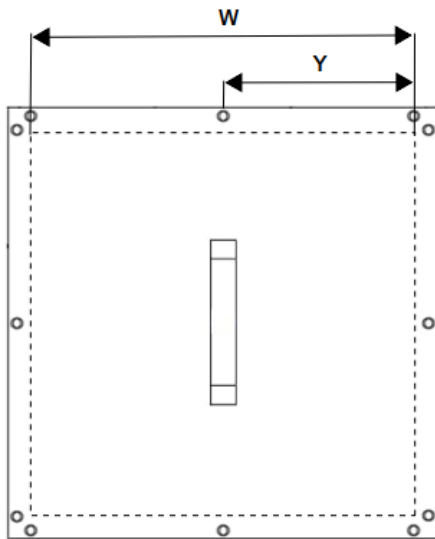
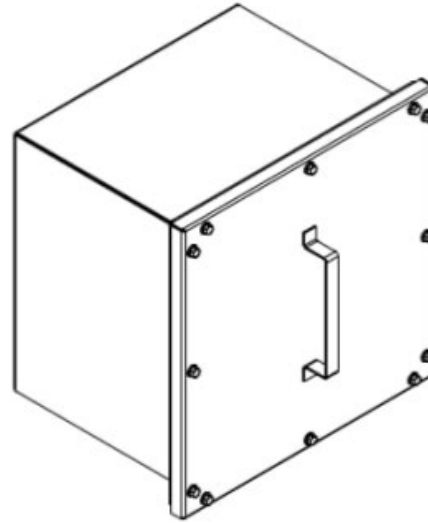

Figure 2



Typical dimensions data, not guaranteed

Frame	Motor Type	Options	General Dimensions										Figure	Approx. internal volume (in ³)	Number of cover bolts
			P	B	Q	M	C	D	L	W	X	Y			
444-447	SD100	T04	-	-	-	-	8	16	20	20	7	10	-	6400	12
444-449	SD100	T04	-	-	-	-	8	16	20	20	8.46	10	-	6400	12
444-447	SD200	T04	-	-	-	-	8	16	20	20	8.5	10	-	6400	12
449-L449	SD200	T04	-	-	-	-	8	16	20	20	8.85	10	-	6400	12
500	SD200	T04	-	-	-	-	8	16	20	20	13.13	10	-	6400	12
444-447	SD100	T05	-	-	-	-	10	20	28.5	24.4	7	12.2	-	13,908	12
444-449	SD100	T05	-	-	-	-	10	20	28.5	24.4	8.46	12.2	-	13,908	12
444-447	SD200	T05	-	-	-	-	10	20	28.5	24.4	8.5	12.2	-	13,908	12
449-L449	SD200	T05	-	-	-	-	10	20	28.5	24.4	8.85	12.2	-	13,908	12
500	SD200	T05	-	-	-	-	10	20	28.5	24.4	13.3	12.2	-	13,908	12

Options T04 and T05 will be without entry holes as standard. Entry holes may be added using option Y96 with values for dimensions P, B, and/or Q

Typical dimensions data, not guaranteed

5.2. Dimensions of accessories

5.2.1. Blower Dimensions

Added Dimensions for Blower Cooled (M08) – SD100

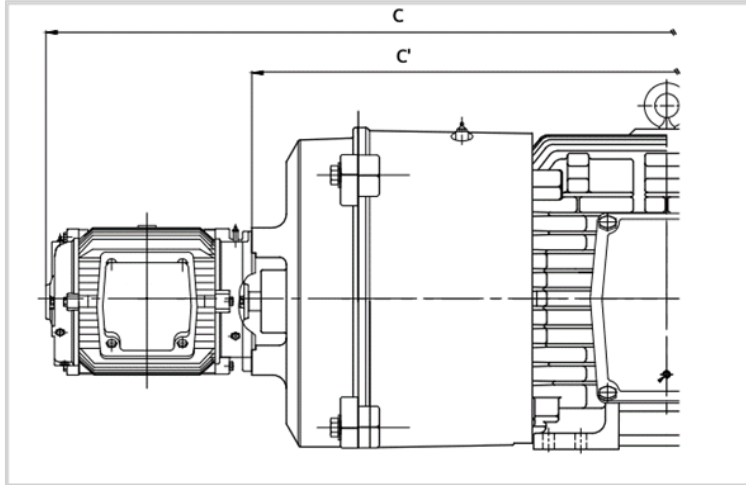

Frame	C'	C
143-145T	-	-
182-184T	-	-
213-215T	-	-
254-256T	30.58	40.17
284-286T	34.21	43.8
324-326T	37.93	47.52
364-365T	40.44	50.04
404-405T	43.53	53.12
444-449T	49.76	59.35

Added Dimensions for Blower Cooled (M08) – SD200

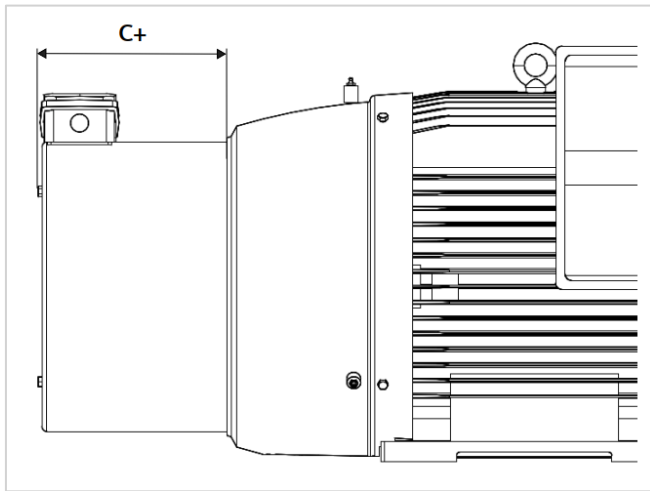

Frame	C+
444-L449	11.87
509-5013	-

5.2.2. Brake Dimensions/Data

Data and Dimensions for Added Brake (H04) – SD100

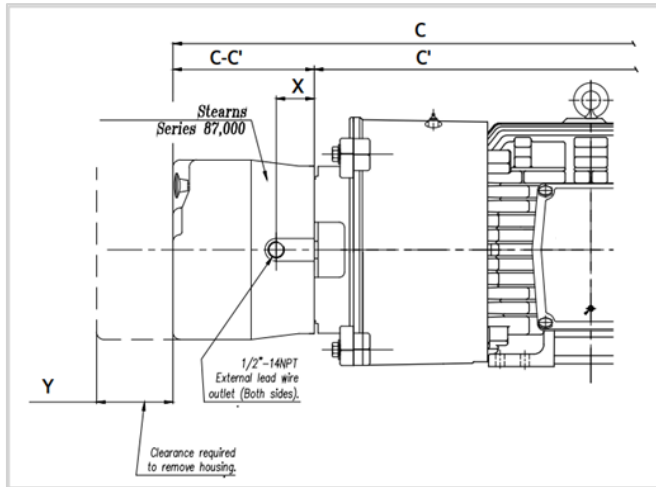

Motor Rating				Brake Details					
2 Pole	4 Pole	6 Pole	8 Pole	IP##	lb-ft	Type	C-C'	X	Y
1-1.5	1	–	–	IP55	3	56,000	4.06"	0.61"	2.94"
3	1.5-2	1	–	IP55	6	56,000	4.06"	0.61"	2.94"
5	3	1.5	–	IP55	10	56,000	4.51"	0.61"	2.94"
–	–	–	1	IP55	10	56,000	4.51"	0.61"	2.94"
7.5	5	2	1.5	IP55	15	56,000	4.51"	0.61"	2.94"
–	–	3	2	IP55	20	56,000	4.51"	0.61"	2.94"
10	–	–	3	IP55	25	56,000	4.51"	0.61"	2.94"
15	7.5	5	–	IP55	35	87,000	7.38"	1.81"	4.69"
20-25	10	7.5	5	IP55	50	87,000	7.88"	2.31"	4.69"
30	15	10	7.5	IP55	75	87,000	8.12"	2.5"	4.69"
40	20-25	15	10	IP55	105	87,000	8.62"	3"	4.69"
–	30	20	15	IP55	125	87,000	8.56"	2.81"	4.69"
–	40	25	20	IP54	175	81,000	11.45"	2.75"	6"
–	50	30	25	IP54	230	81,000	11.95"	3.25"	6"
–	60-75	40-50	30-40	IP54	330	82,000	12.76"	4.5"	6"
–	100	60	50	IP54	440	82,000	14.01"	5.75"	6"
–	125	75	60	IP54	500	86,000	13.57"	5.38"	6"
–	150	–	75	IP54	750	86,000	13.57"	5.38"	6"
–	200-250	100-125	100	IP54	1000	86,000	13.57"	5.38"	6"

Data and Dimensions for Added Brake (H04) – SD200

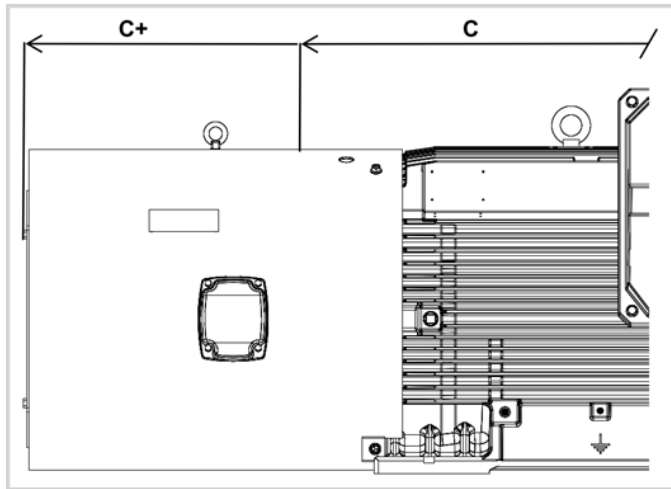

Motor Rating			Brake Details		
4 Pole	6 Pole	8 Pole	IP##	lb-ft	C+
HP	HP	HP			
125, 150	100	75	IP55	750	20"
200, 250	125, 150	100, 125	IP55	1000	20"
300	200	150	IP55	1200	20"

5.2.3. Encoder Dimensions

Added Dimensions Shaft Mounted Encoder (G05)

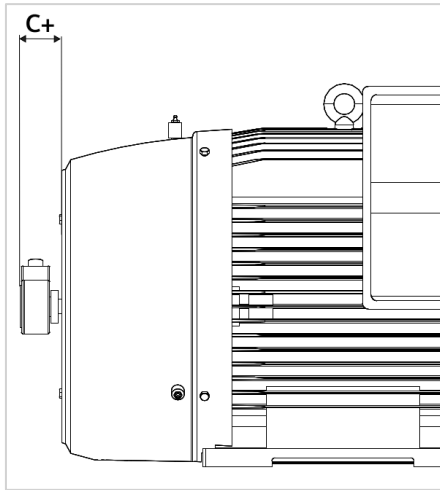

Frame	C
All	2.86

Added Dimensions C-Face Mounted Encoder (G06) – SD200

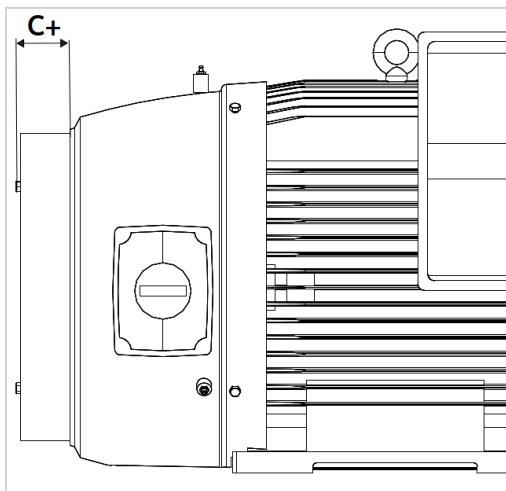

Frame	C
444-L449	2.97

5.2.4. Drip Cover and NDE Shaft

Drip Cover Dimensions

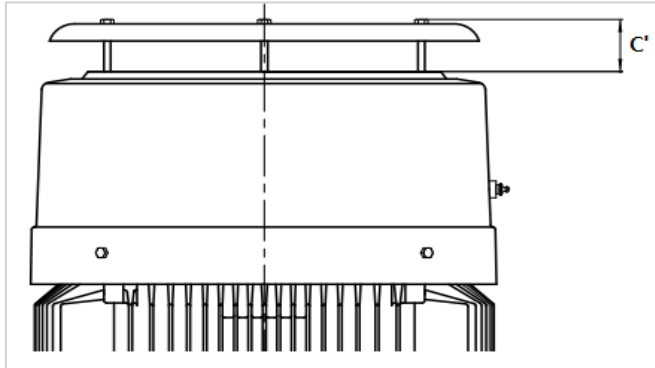

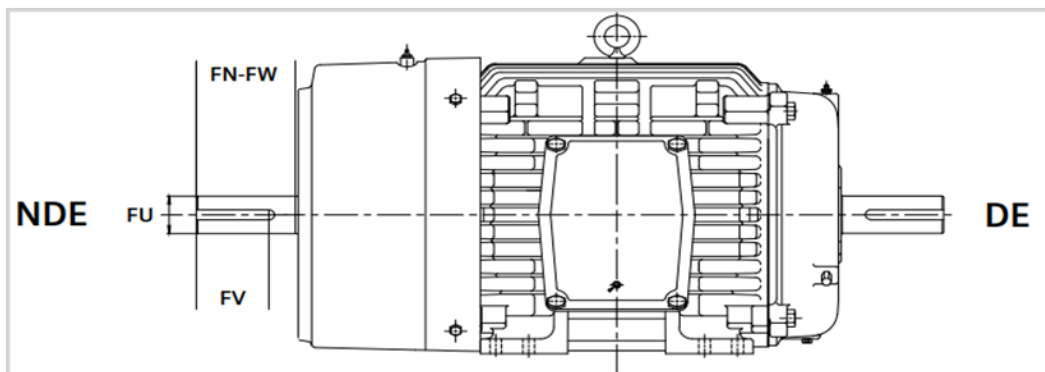

Frame	C'
140	1.54
180	1.7
210	1.49
250	2.15
280	2.15
320	2.15
360	2.15
400	2.15
440	2.68



Frame	FU	Key	Order Code = M53			Order Code = M52		
			NEMA Standard Short Shaft			NEMA Standard Long Shaft		
			FN-FW	FV	Key Length	FN-FW	FV	Key Length
143-145T	0.625	0.188	–	–	–	1.62	1.38	0.91
182-184T	0.875	0.188	–	–	–	2.25	2	1.41
213-215T	1.125	0.25	–	–	–	2.75	2.5	1.75
254-256T	1.375	0.312	–	–	–	3.37	3.12	2.37
284-286T	1.625	0.375	3.75	3	1.87	4	3.75	2.87
324-326T	1.875	0.5	0.375	3.5	2	4.62	4.37	3.25
364-365T	1.875	0.5	3.75	3.5	2	4.62	4.37	3.25
404-405T	2.125	0.5	4.25	4	2.75	5.25	5	3.87
444-449T	2.375	0.625	4.75	4.5	3	5.87	5.62	4.25

5.3. General packing weights and dimensions

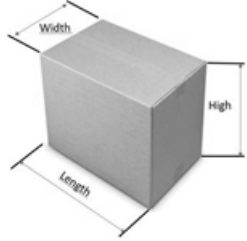
5.3.1. Standard Packing

Pallet Dimensions					Cardboard Box Dimensions				Cartons per pallet	
										
Frame	Length (inches)	Width (inches)	Height (inches)	Weight (lbs)	Length (inches)	Width (inches)	Height (inches)	Weight (lbs)	Cartons per layer	Total per pallet
140	47.24	39.37	39.57 ¹	61.6	15.35	12.60	9.45	2.4	8	32
180	47.24	39.37	44.49 ¹	61.6	19.49	13.58	11.02	4.0	6	18
180 (XP and IEEE)	47.24	39.37	36.61 ¹	61.6	20.08	15.55	12.99	6.2	6	18
210	47.24	39.37	36.61 ¹	61.6	24.02	17.52	17.72	7.7	4	8
250	59.06	42.52	40.16 ¹	83.6	29.33	20.08	19.29	10.6	4	8
280	36.61	25.20	6.30	39.6	-	-	-	-	1	
320	26.77	28.35	6.30	46.2	-	-	-	-	1	
360	41.34	34.65	6.30	66	-	-	-	-	1	
400	47.24	34.65	6.30	99	-	-	-	-	1	
444	50.39	40.94	6.30	121	-	-	-	-	1	
447	56.30	40.94	6.30	149.6	-	-	-	-	1	
449	62.99	40.94	6.30	158.4	-	-	-	-	1	
S449	73.23	47.24	6.30	209	-	-	-	-	1	
500	87.40	49.21	9.45	303.6	-	-	-	-	1	

1. Height with cartons considering full pallet

Note: Weight of wood pallets are for estimate purpose only and may change due to climate conditions

5.3.2. Export Packing



Frame	Length (inches)	Width (inches)	Height (inches)	Weight (Lbs)	Motors per box
140-210	26.1	18.9	19.4	39.6	1
250	31.7	22.8	23.4	52.8	1
280	37.6	25.0	24.3	77.0	1
320	36.4	28.5	26.7	96.8	1
360	39.2	32.0	28.7	114.4	1
400	47.2	39.9	33.5	160.6	1
444-447	57.3	48.0	36.5	215.6	1
449	61.4	40.4	33.5	231.0	1
S449	73.0	42.0	35.9	308.0	1
500	98.4	49.2	41.3	396.0	1

Note: Weight of wood crates are for estimate purpose only and may change due to climate conditions

6. Indexes

6.1. Short Code Index (alphabetical).....283

6.2. Low Voltage NEMA to Next Generation Crossover index..... 288

6.1. Short Code Index (alphabetical)

Codes	Description	Next Generation Low Voltage NEMA Motors		Low Voltage NEMA Motors	
		Technical	Pricing	Technical	Pricing
A46	Space Heaters 115V Single Phase, Max Temp 160°C	i	\$	i	\$
A47	Space Heaters 230V Single Phase, Max Temp 160°C	i	\$	i	\$
A48	Space Heaters 115/230V Single Phase, Max Temp 160°C	i	\$	i	\$
A50	Install BRG RTD's-100 Ohm Platinum- Both Ends & Terminal Heads/Block	i	\$	–	–
A51	Bearing RTD's-100 Ohm Platinum – Both Ends & Terminal Heads/Block	i	\$	i	\$
A66	ROBERTSHAW Vibration Detectors, Model 366-D8 120VAC			i	\$
A67	Provision Only for Vibration Sensors	i	\$	i	\$
A68	Metrix Sensors Installed on DE and NDE, top of the end shield	i	\$	–	–
A90	Control Module	i	\$	i	\$
B07	Stackable Crate Packing			i	\$
B09	Export Packaging Sea Freight – ABB Standard	i	\$	i	\$
B10	Export Packaging Special Export Box				
B11	Export Packaging Sea Freight – ABB Standard + sensors	i	\$	i	\$
B27	+40°C to -30°C Ambient Temp	i	\$	i	\$
B28	+40°C to -40°C Ambient Temp	i	\$	i	\$
B29	+40°C to -50°C Ambient Temp	i	\$	i	\$
C00	Insulation Class H	–	–	i	\$
C01	Insulation Vacuum Pressure Impregnation (VPI)	i	\$	i	\$
C03	Spike Resistant Wire	i	\$	i	\$
C04	Insulation Moisture/Powerhouse (Extra Dip & Bake)	i	\$	i	\$
C07	Insulation Fungus Protection - No UL	i	\$	i	\$
C08	Insulation Tropicalization (Extra Dip & Bake + Fungus Spray)	i	\$	i	\$
C40	Re-rate 400V to 415V, 50HZ	–	–	i	\$
C41	Re-rate 400V to 380V, 50HZ	–	–	i	\$
D05	Documentation in Spanish	i	\$	i	\$
F00	Certificate of Compliance	i	\$	i	\$
F01	Certificate of Origin - Stamped by Chamber of Commerce	i	\$	i	\$
F03	Standard Performance Curves	i	\$	i	\$
F04	Acceleration Time Calculation	i	\$	i	\$
F05	Polarization Index	i	\$	i	\$
F07	Special Calculated Data	i	\$	i	\$
F08	Shaft Torsional Analysis (includes shaft drawing)	i	\$	i	\$
F09	Bearing L10 Calculation	i	\$	i	\$

		Next Generation Low Voltage NEMA Motors	Low Voltage NEMA Motors
F10	Routine Test Report	i	\$
F12	Routine Test Report (Witnessed)	i	\$
F15	Complete Test	i	\$
F17	Complete Test (Witnessed)	i	\$
F20	Routine Test + Vibration	i	\$
F22	Routine Test + Vibration (Witnessed)	i	\$
F27	Performance Load Test (Curve Report)	i	\$
F30	Noise Test	i	\$
F32	Noise Test (Witnessed)	i	\$
F36	Routine Test Report of Electrical Duplicate Design	i	\$
F37	Type Test Report of Electrical Duplicate Design	i	\$
F40	Stall Time Curve (Thermal Limit Curve)	i	\$
F42	Standard Dimensional Sheet	i	\$
F43	Non-Standard Dimension Sheet	i	\$
F44	Conduit Box Dimension Sheet	i	\$
F45	Wiring Diagram	i	\$
F46	Instruction and Operation Manual in English	i	\$
F47	Renewal Parts	i	\$
F48	CAD Drawing (Dwg Format) Customer/Application Specific	i	\$
F49	Performance Data Sheets	i	\$
F50	Customer Specific Data Sheets	i	\$
F51	Shaft Profile Detail (included materials data)	i	\$
F60	Visual Inspection Proof (Max 8X Photos)	i	\$
F70	Inspection Test Plan	i	\$
F71	Paint Report (thickness and adherence)	i	\$
F81	Advanced Document Package	i	\$
F82	Project Document Package	i	\$
G05	DYNAPAR Encoder HS35 1024 PPR	i	\$
G06	C-Face Mounted SLIM Tach Encoder	i	\$
H04	C-Face Mounted Brake	-	i
Jx0	Separate Condulet on Main Box Side	-	i
Jx2	Condulet to Main Box	-	i
Jx3	Aux Box to Main Box	-	i
Jx4	Condulet Opposite to Main Box Side	-	i
Jx5	Aux Box Opposite to Main Box Side	-	i
Jx6	Explosion Proof Condulet Opposite to Main Box Side	-	i
Jx7	Aux Box to Left of Main Box	-	i
J84	Conduit Box Orientation 90° CCW (Entry from DE)	i	\$

		Next Generation Low Voltage NEMA Motors		Low Voltage NEMA Motors	
J85	Conduit Box Orientation 180° CCW (Entry from Top)	i	\$	i	\$
J86	Conduit Box Orientation 270° CCW (Entry from ODE)	i	\$	i	\$
K10	IEEE 841 Features	i	\$	i	\$
K20	API 610	-	-	i	\$
K21	Extra High Thrust	-	-	i	\$
K33	Drip Cover	i	\$	i	\$
K34	Vertical Lifting Devices (No Drip Cover)	-	-	i	\$
K38	Provisions for Dowel Holes	i	\$	i	\$
K41	Keyless Shaft	i	\$	i	\$
K42	Retrofit S449 Shaft Extension	i	\$	-	-
K70	Rotation Arrow Bidirectional (Not for Uni-Directional)	i	\$	i	\$
K71	Rotation Arrow Clockwise (From NDE)	i	\$	i	\$
K72	Rotation Arrow Counterclockwise (From NDE)	i	\$	i	\$
K80	BURNDY HYDENT YA Type Terminals	i	\$	i	\$
K81	Special Cable Leads, 60" Long	i	\$	-	-
K82	Special Cable Leads, 120" Long	i	\$	-	-
K83	Terminal Block - 3 Lead Only	i	\$	i	\$
K89	Sealed Leads	i	\$	i	\$
L01	Cast Iron Main Terminal Box in Lieu of Aluminum	-	-	i	\$
L20	Lifting Eyebolt	-	-	i	\$
L22	Stainless Steel Hardware (Includes T Drain SS)	i	\$	i	\$
L27	Ground Bolts - Qty 2	i	\$	i	\$
L29	Shaft Grounding Brush	i	\$	i	\$
L45	SS T-Slot Breather Drain	i	\$	i	\$
L46	CROUSE HINDS UL Approved Breather Drain	i	\$	i	\$
L49	Automatic Grease Relief Fitting	i	\$	-	-
L50	Bearing Insulation for DE	i	\$	-	-
L51	Bearing Insulation for NDE	i	\$	-	-
L54	Provisions for Oil Mist	i	\$	i	\$
L55	Oil Mist Ready	i	\$	i	\$
L57	MOBIL 28 - High or Low - Special Grease	i	\$	i	\$
L58	MOBILITH SHC 100 - Special Grease	i	\$	i	\$
L60	ALEMITE and Grease Relief Fitting	-	-	i	\$
L61	Insulated Bearing - INSOCOAT (Both Ends)	i	\$	i	\$
L62	Insulated Bearing - INSOCOAT (On DE)	i	\$	i	\$
L64	Insulated Bearing - INSOCOAT (On NDE)	i	\$	i	\$
L65	Roller Instead of Ball Bearings	-	-	i	\$
L66	Insulated Bearings on Both Ends	-	-	i	\$

		Next Generation Low Voltage NEMA Motors		Low Voltage NEMA Motors	
L67	Insulated NDE Only	-	-	i	\$
L68	Sealed Ball Bearings (Both Ends)	i	\$	i	\$
L69	Hybrid (Ceramic Ball) Bearings - Both Ends	i	\$	i	\$
L70	Hybrid (Ceramic Ball) Bearings – NDE	i	\$	i	\$
L71	Hybrid (Ceramic Ball) Bearings – DE	i	\$	i	\$
L76	Shaft Slinger & O Ring	i	\$	i	\$
L79	INPRO/SEAL DE	i	\$	i	\$
L80	INPRO/SEAL ODE	i	\$	i	\$
L81	INPRO/SEAL Both Ends	i	\$	i	\$
L84	Brass Seal	-	-	i	\$
L86	INPRO/SEAL MGS Shaft Grounding – on DE	i	\$	i	\$
L90	IP66 Ingress Protection	-	-	i	\$
L91	IP56 Ingress Protection	i	\$	i	\$
L92	IP65 Ingress Protection	-	-	i	\$
M05	Larger Fan	-	-	i	\$
M08	Separately Driven Fan	i	\$	i	\$
M09	Aluminum Fan	-	-	i	\$
M10	Bronze Fan	i	\$	i	\$
M18	Non-Reverse Ratchet	-	-	i	\$
M21	Additional Nameplate (Without Logos)	i	\$	i	\$
M25	Class II, Division 2, Groups F & G, T4A Temp Code	i	\$	i	\$
M28	Stainless Steel Eyebolt	-	-	i	\$
M2Y	Special Voltage (200 - 600V)	-	-	i	\$
M6Y	Special Winding (200-600V)	i	\$	-	-
M32	Class II, Group E Hazardous Area	-	-	i	\$
M39	Vertical Jacking Provisions	i	\$	i	\$
M42	Shaft Ring Brush (Steel) – NDE (AEGIS)	-	-	i	\$
M52	NEMA Std Long Shaft – NDE	i	\$	i	\$
M53	NEMA Std Short Shaft – NDE	i	\$	i	\$
M57	(C4140) Carbon Steel Shaft	i	\$	i	\$
M69	Precision Balance	i	\$	i	\$
M70	Extra Precision Balance	i	\$	i	\$
N01	2 Part Epoxy (Industrial – Coastal Low Salt)	i	\$	i	\$
N02	3 Part Epoxy (Industrial – Coastal Moderate Salt)	i	\$	i	\$
N03	Primer Only	i	\$	i	\$
N05	3 Part Epoxy (Coastal – Offshore High Salt)	i	\$	i	\$
N06	2 Part Epoxy C4 (Industrial-Coastal Moderate Salt)	i	\$	i	\$
N07	2 Part Epoxy C5I/C5M (Coastal-Offshore High Salt)	i	\$	i	\$

		Next Generation Low Voltage NEMA Motors		Low Voltage NEMA Motors	
*Rx0	Cast Iron Aux Box for - Position 1 (F1 DE)	i	\$	-	-
*Rx1	Cast Iron Aux Box for - Position 2 (F2 DE)	i	\$	-	-
*Rx2	Cast Iron Aux Box for - Position 4 (F1 NDE)	i	\$	-	-
*Rx3	Cast Iron Aux Box for - Position 5 (F2 NDE)	i	\$	-	-
*Rx4	Condulet Box for - Position 1 (F1 DE)	i	\$	-	-
*Rx5	Condulet Box for - Position 2 (F2 DE)	i	\$	-	-
*Rx6	Condulet Box for - Position 4 (F1 NDE)	i	\$	-	-
*Rx7	Condulet Box for - Position 5 (F2 NDE)	i	\$	-	-
T00	Main Terminal Box – at 45° Angle	i	\$	-	-
T03	Main Terminal Box – Oversized Steel (Centered Cable Entry)	i	\$	-	-
T04	Steel terminal box - oversized 20X20X16(in) with blank entry	i	\$	i	\$
T05	Steel terminal box - oversized 28.5X24.4X20(in) with blank entry	i	\$	-	-
T06	Steel terminal box - oversized 18.5X22X7.5(in) with blank entry	i	\$	-	-
T50	Dual Entry Hole Terminal Box	i	\$	-	-
Y50	Special Shaft on Drive End	i	\$	i	\$
Y51	Special Shaft on Non-Drive End	i	\$	i	\$
Y60	Special Color (Provide RAL#)	i	\$	i	\$
Y61	Special color with Special Paint system (Provide RAL#)	i	\$	i	\$
Y80	Derate-Alt-Amb (Nameplate Change)	i	\$	i	\$
Y82	Auxiliary Nameplate Max. 40 Characters (Aux Tag)	i	\$	i	\$
Y85	Special Cable Length	-	-	i	\$
Y96	Non-Standard NPT entry	i	\$	-	-

6.2. Low Voltage NEMA to Next Generation Crossover index

			Phase Out - NEMA Motor SD100			Next Generation NEMA SD200		
HP	RPM	Voltage	Frame	Type	Part Number	Frame	Type	Part Number
125	3600	460	444TS	SD100	1LE23214DA112AA3	444TS	SD200	1LE63214FA112AA1
150	3600	460	445TS	SD100	1LE23214DA212AA3	445TS	SD200	1LE63214FA212AA1
200	3600	460	447TS	SD100	1LE23214DA312AA3	447TS	SD200	1LE63214GA112AA1
250	3600	460	449TS	SD100	1LE23214DA512AA3	449TS	SD200	1LE63214GA212AA1
300	3600	460	449TS	SD100	1LE23214DA612AA3	449TS	SD200	1LE63214GA312AA1
350	3600	460	S449SS	SD100	1LE23214GA112AA3	L449TS	SD200	1LE63214HA112AA1
400	3600	460	S449SS	SD100	1LE23214GA312AA3	L449TS	SD200	1LE63214HA212AA1
125	1800	460	B444T	SD100	1LE23214EB112AA3	444T	SD200	1LE63214BB112AA1
125	1800	460	444TS	SD100	1LE23214DB112AA3	444TS	SD200	1LE63214FB112AA1
125	1800	460	444T	SD100	1LE23214CB112AA3	R444T	SD200	1LE63214SB112AA1
150	1800	460	B445T	SD100	1LE23214EB212AA3	445T	SD200	1LE63214BB212AA1
150	1800	460	445TS	SD100	1LE23214DB212AA3	445TS	SD200	1LE63214FB212AA1
150	1800	460	445T	SD100	1LE23214CB212AA3	R445T	SD200	1LE63214SB212AA1
200	1800	460	B447T	SD100	1LE23214EB312AA3	447T	SD200	1LE63214CB112AA1
200	1800	460	447TS	SD100	1LE23214DB312AA3	447TS	SD200	1LE63214GB112AA1
200	1800	460	447T	SD100	1LE23214CB312AA3	R447T	SD200	1LE63214TB112AA1
250	1800	460	B449T	SD100	1LE23214EB512AA3	449T	SD200	1LE63214CB212AA1
250	1800	460	449TS	SD100	1LE23214DB512AA3	449TS	SD200	1LE63214GB212AA1
250	1800	460	449T	SD100	1LE23214CB512AA3	R449T	SD200	1LE63214TB212AA1
300	1800	460	B449T	SD100	1LE23214EB612AA3	449T	SD200	1LE63214CB312AA1
300	1800	460	449TS	SD100	1LE23214DB612AA3	449TS	SD200	1LE63214GB312AA1
300	1800	460	449T	SD100	1LE23214CB612AA3	R449T	SD200	1LE63214TB312AA1
350	1800	460	S449SS	SD100	1LE23214GB212AA3	L449TS	SD200	1LE63214HB112AA1
350	1800	460	S449LS	SD100	1LE23214FB212AA3	RL449T	SD200	1LE63214UB112AA1
400	1800	460	S449SS	SD100	1LE23214GB312AA3	L449TS	SD200	1LE63214HB212AA1
400	1800	460	S449LS	SD100	1LE23214FB312AA3	R509	SD200	1LE63215RB112AK1
100	1200	460	B444T	SD100	1LE23214EC112AA3	444T	SD200	1LE63214BC112AA1
100	1200	460	444TS	SD100	1LE23214DC112AA3	444TS	SD200	1LE63214FC112AA1
100	1200	460	444T	SD100	1LE23214CC112AA3	R444T	SD200	1LE63214SC112AA1

			Phase Out - NEMA Motor SD100			Next Generation NEMA SD200		
125	1200	460	B445T	SD100	1LE23214EC212AA3	445T	SD200	1LE63214BC212AA1
125	1200	460	445TS	SD100	1LE23214DC212AA3	445TS	SD200	1LE63214FC212AA1
125	1200	460	445T	SD100	1LE23214CC212AA3	R445T	SD200	1LE63214SC212AA1
150	1200	460	B447T	SD100	1LE23214EC312AA3	447T	SD200	1LE63214CC112AA1
150	1200	460	447TS	SD100	1LE23214DC312AA3	447TS	SD200	1LE63214GC112AA1
150	1200	460	447T	SD100	1LE23214CC312AA3	R447T	SD200	1LE63214TC112AA1
200	1200	460	B449T	SD100	1LE23214EC512AA3	449T	SD200	1LE63214CC212AA1
200	1200	460	449TS	SD100	1LE23214DC512AA3	449TS	SD200	1LE63214GC212AA1
200	1200	460	449T	SD100	1LE23214CC512AA3	R449T	SD200	1LE63214TC212AA1
250	1200	460	B449T	SD100	1LE23214EC612AA3	449T	SD200	1LE63214CC312AA1
250	1200	460	449TS	SD100	1LE23214DC612AA3	449TS	SD200	1LE63214GC312AA1
250	1200	460	449T	SD100	1LE23214CC612AA3	R449T	SD200	1LE63214TC312AA1
300	1200	460	S449LS	SD100	1LE23214FC112AA3	RL449T	SD200	1LE63214UC112AA1
75	900	460	B444T	SD100	1LE23214ED112AA3	444T	SD200	1LE63214BD112AA1
75	900	460	444TS	SD100	1LE23214DD112AA3	444TS	SD200	1LE63214FD112AA1
75	900	460	444T	SD100	1LE23214CD112AA3	R444T	SD200	1LE63214SD112AA1
100	900	460	B445T	SD100	1LE23214ED212AA3	445T	SD200	1LE63214BD212AA1
100	900	460	445TS	SD100	1LE23214DD212AA3	445TS	SD200	1LE63214FD212AA1
100	900	460	445T	SD100	1LE23214CD212AA3	R445T	SD200	1LE63214SD212AA1
125	900	460	B447T	SD100	1LE23214ED312AA3	447T	SD200	1LE63214CD112AA1
125	900	460	447TS	SD100	1LE23214DD312AA3	447TS	SD200	1LE63214GD112AA1
125	900	460	447T	SD100	1LE23214CD312AA3	R447T	SD200	1LE63214TD112AA1
150	900	460	B447T	SD100	1LE23214ED412AA3	449T	SD200	1LE63214CD212AA1
150	900	460	447TS	SD100	1LE23214DD412AA3	449TS	SD200	1LE63214GD212AA1
150	900	460	447T	SD100	1LE23214CD412AA3	R449T	SD200	1LE63214TD212AA1
200	900	460	S449SS	SD100	1LE23214GD112AA3	L449TS	SD200	1LE63214HD112AA1
200	900	460	S449LS	SD100	1LE23214FD112AA3	RL449T	SD200	1LE63214UD112AA1
250	900	460	S449LS	SD100	1LE23214FD212AA3	RL449T	SD200	1LE63214UD212AA1
125	3600	575	444TS	SD100	1LE23214DA113AA3	444TS	SD200	1LE63214FA113AA1
150	3600	575	445TS	SD100	1LE23214DA213AA3	445TS	SD200	1LE63214FA213AA1
200	3600	575	447TS	SD100	1LE23214DA313AA3	447TS	SD200	1LE63214GA113AA1
250	3600	575	449TS	SD100	1LE23214DA513AA3	449TS	SD200	1LE63214GA213AA1
300	3600	575	449TS	SD100	1LE23214DA613AA3	449TS	SD200	1LE63214GA313AA1

			Phase Out - NEMA Motor SD100			Next Generation NEMA SD200		
350	3600	575	S449SS	SD100	1LE23214GA113AA3	L449TS	SD200	1LE63214HA113AA1
400	3600	575	S449SS	SD100	1LE23214GA313AA3	L449TS	SD200	1LE63214HA213AA1
125	1800	575	B444T	SD100	1LE23214EB113AA3	444T	SD200	1LE63214BB113AA1
125	1800	575	444TS	SD100	1LE23214DB113AA3	444TS	SD200	1LE63214FB113AA1
125	1800	575	444T	SD100	1LE23214CB113AA3	R444T	SD200	1LE63214SB113AA1
150	1800	575	B445T	SD100	1LE23214EB213AA3	445T	SD200	1LE63214BB213AA1
150	1800	575	445TS	SD100	1LE23214DB213AA3	445TS	SD200	1LE63214FB213AA1
150	1800	575	445T	SD100	1LE23214CB213AA3	R445T	SD200	1LE63214SB213AA1
200	1800	575	B447T	SD100	1LE23214EB313AA3	447T	SD200	1LE63214CB113AA1
200	1800	575	447TS	SD100	1LE23214DB313AA3	447TS	SD200	1LE63214GB113AA1
200	1800	575	447T	SD100	1LE23214CB313AA3	R447T	SD200	1LE63214TB113AA1
250	1800	575	B449T	SD100	1LE23214EB513AA3	449T	SD200	1LE63214CB213AA1
250	1800	575	449TS	SD100	1LE23214DB513AA3	449TS	SD200	1LE63214GB213AA1
250	1800	575	449T	SD100	1LE23214CB513AA3	R449T	SD200	1LE63214TB213AA1
300	1800	575	B449T	SD100	1LE23214EB613AA3	449T	SD200	1LE63214CB313AA1
300	1800	575	449TS	SD100	1LE23214DB613AA3	449TS	SD200	1LE63214GB313AA1
300	1800	575	449T	SD100	1LE23214CB613AA3	R449T	SD200	1LE63214TB313AA1
350	1800	575	S449SS	SD100	1LE23214GB213AA3	L449TS	SD200	1LE63214HB113AA1
350	1800	575	S449LS	SD100	1LE23214FB213AA3	RL449T	SD200	1LE63214UB113AA1
400	1800	575	S449SS	SD100	1LE23214GB313AA3	L449TS	SD200	1LE63214HB213AA1
400	1800	575	S449LS	SD100	1LE23214FB313AA3	R509	SD200	1LE63215RB113AK1
100	1200	575	B444T	SD100	1LE23214EC113AA3	444T	SD200	1LE63214BC113AA1
100	1200	575	444TS	SD100	1LE23214DC113AA3	444TS	SD200	1LE63214FC113AA1
100	1200	575	444T	SD100	1LE23214CC113AA3	R444T	SD200	1LE63214SC113AA1
125	1200	575	B445T	SD100	1LE23214EC213AA3	445T	SD200	1LE63214BC213AA1
125	1200	575	445TS	SD100	1LE23214DC213AA3	445TS	SD200	1LE63214FC213AA1
125	1200	575	445T	SD100	1LE23214CC213AA3	R445T	SD200	1LE63214SC213AA1
150	1200	575	B447T	SD100	1LE23214EC313AA3	447T	SD200	1LE63214CC113AA1
150	1200	575	447TS	SD100	1LE23214DC313AA3	447TS	SD200	1LE63214GC113AA1
150	1200	575	447T	SD100	1LE23214CC313AA3	R447T	SD200	1LE63214TC113AA1
200	1200	575	B449T	SD100	1LE23214EC513AA3	449T	SD200	1LE63214CC213AA1
200	1200	575	449TS	SD100	1LE23214DC513AA3	449TS	SD200	1LE63214GC213AA1
200	1200	575	449T	SD100	1LE23214CC513AA3	R449T	SD200	1LE63214TC213AA1

			Phase Out - NEMA Motor SD100			Next Generation NEMA SD200		
250	1200	575	B449T	SD100	1LE23214EC613AA3	449T	SD200	1LE63214CC313AA1
250	1200	575	449TS	SD100	1LE23214DC613AA3	449TS	SD200	1LE63214GC313AA1
250	1200	575	449T	SD100	1LE23214CC613AA3	R449T	SD200	1LE63214TC313AA1
300	1200	575	S449LS	SD100	1LE23214FC113AA3	RL449T	SD200	1LE63214UC113AA1
75	900	575	B444T	SD100	1LE23214ED113AA3	444T	SD200	1LE63214BD113AA1
75	900	575	444TS	SD100	1LE23214DD113AA3	444TS	SD200	1LE63214FD113AA1
75	900	575	444T	SD100	1LE23214CD113AA3	R444T	SD200	1LE63214SD113AA1
100	900	575	B445T	SD100	1LE23214ED213AA3	445T	SD200	1LE63214BD213AA1
100	900	575	445TS	SD100	1LE23214DD213AA3	445TS	SD200	1LE63214FD213AA1
100	900	575	445T	SD100	1LE23214CD213AA3	R445T	SD200	1LE63214SD213AA1
125	900	575	B447T	SD100	1LE23214ED313AA3	447T	SD200	1LE63214CD113AA1
125	900	575	447TS	SD100	1LE23214DD313AA3	447TS	SD200	1LE63214GD113AA1
125	900	575	447T	SD100	1LE23214CD313AA3	R447T	SD200	1LE63214TD113AA1
150	900	575	B447T	SD100	1LE23214ED413AA3	449T	SD200	1LE63214CD213AA1
150	900	575	447TS	SD100	1LE23214DD413AA3	449TS	SD200	1LE63214GD213AA1
150	900	575	447T	SD100	1LE23214CD413AA3	R449T	SD200	1LE63214TD213AA1
200	900	575	S449SS	SD100	1LE23214GD113AA3	L449TS	SD200	1LE63214HD113AA1
200	900	575	S449LS	SD100	1LE23214FD113AA3	RL449T	SD200	1LE63214UD113AA1
250	900	575	S449LS	SD100	1LE23214FD213AA3	RL449T	SD200	1LE63214UD213AA1

			Phase Out - NEMA Motor SD100 IEEEE841			Next Generation NEMA SD200 841		
HP	RPM	Voltage	Frame	Type	Part Number	Frame	Type	Part Number
125	3600	460	444TS	SD100 IEEEE841	1LE24214DA112AA3	444TS	SD200 841	1LE63224FA112AA1
150	3600	460	445TS	SD100 IEEEE841	1LE24214DA212AA3	445TS	SD200 841	1LE63224FA212AA1
200	3600	460	447TS	SD100 IEEEE841	1LE24214DA312AA3	447TS	SD200 841	1LE63224GA112AA1
250	3600	460	449TS	SD100 IEEEE841	1LE24214DA512AA3	449TS	SD200 841	1LE63224GA212AA1
300	3600	460	449TS	SD100 IEEEE841	1LE24214DA612AA3	449TS	SD200 841	1LE63224GA312AA1
350	3600	460	S449SS	SD100 IEEEE841	1LE24214GA112AA3	L449TS	SD200 841	1LE63224HA112AA1
400	3600	460	S449SS	SD100 IEEEE841	1LE24214GA312AA3	L449TS	SD200 841	1LE63224HA212AA1
125	1800	460	B444T	SD100 IEEEE841	1LE24214EB112AA3	444T	SD200 841	1LE63224BB112AA1
125	1800	460	444TS	SD100 IEEEE841	1LE24214DB112AA3	444TS	SD200 841	1LE63224FB112AA1
125	1800	460	444T	SD100 IEEEE841	1LE24214CB112AA3	R444T	SD200 841	1LE63224SB112AA1
150	1800	460	B445T	SD100 IEEEE841	1LE24214EB212AA3	445T	SD200 841	1LE63224BB212AA1
150	1800	460	445TS	SD100 IEEEE841	1LE24214DB212AA3	445TS	SD200 841	1LE63224FB212AA1
150	1800	460	445T	SD100 IEEEE841	1LE24214CB212AA3	R445T	SD200 841	1LE63224SB212AA1
200	1800	460	B447T	SD100 IEEEE841	1LE24214EB312AA3	447T	SD200 841	1LE63224CB112AA1
200	1800	460	447TS	SD100 IEEEE841	1LE24214DB312AA3	447TS	SD200 841	1LE63224GB112AA1
200	1800	460	447T	SD100 IEEEE841	1LE24214CB312AA3	R447T	SD200 841	1LE63224TB112AA1
250	1800	460	B449T	SD100 IEEEE841	1LE24214EB512AA3	449T	SD200 841	1LE63224CB212AA1
250	1800	460	449TS	SD100 IEEEE841	1LE24214DB512AA3	449TS	SD200 841	1LE63224GB212AA1
250	1800	460	449T	SD100 IEEEE841	1LE24214CB512AA3	R449T	SD200 841	1LE63224TB212AA1
300	1800	460	S449SS	SD100 IEEEE841	1LE24214GB112AA3	449TS	SD200 841	1LE63224GB312AA1
300	1800	460	S449LS	SD100 IEEEE841	1LE24214FB112AA3	R449T	SD200 841	1LE63224TB312AA1
350	1800	460	S449SS	SD100 IEEEE841	1LE24214GB212AA3	L449TS	SD200 841	1LE63224HB112AA1
350	1800	460	S449LS	SD100 IEEEE841	1LE24214FB212AA3	RL449T	SD200 841	1LE63224UB112AA1
400	1800	460	S449SS	SD100 IEEEE841	1LE24214GB312AA3	L449TS	SD200 841	1LE63224HB212AA1
400	1800	460	S449LS	SD100 IEEEE841	1LE24214FB312AA3	RL449T	SD200 841	1LE63224UB212AA1
100	1200	460	B444T	SD100 IEEEE841	1LE24214EC112AA3	444T	SD200 841	1LE63224BC112AA1
100	1200	460	444TS	SD100 IEEEE841	1LE24214DC112AA3	444TS	SD200 841	1LE63224FC112AA1
100	1200	460	444T	SD100 IEEEE841	1LE24214CC112AA3	R444T	SD200 841	1LE63224SC112AA1
125	1200	460	B445T	SD100 IEEEE841	1LE24214EC212AA3	445T	SD200 841	1LE63224BC212AA1
125	1200	460	445TS	SD100 IEEEE841	1LE24214DC212AA3	445TS	SD200 841	1LE63224FC212AA1
125	1200	460	445T	SD100 IEEEE841	1LE24214CC212AA3	R445T	SD200 841	1LE63224SC212AA1
150	1200	460	B447T	SD100 IEEEE841	1LE24214EC312AA3	447T	SD200 841	1LE63224CC112AA1

			Phase Out - NEMA Motor SD100 IEEEE841			Next Generation NEMA SD200 841		
150	1200	460	447TS	SD100 IEEEE841	1LE24214DC312AA3	447TS	SD200 841	1LE63224GC112AA1
150	1200	460	447T	SD100 IEEEE841	1LE24214CC312AA3	R447T	SD200 841	1LE63224TC112AA1
200	1200	460	B449T	SD100 IEEEE841	1LE24214EC512AA3	449T	SD200 841	1LE63224CC212AA1
200	1200	460	449TS	SD100 IEEEE841	1LE24214DC512AA3	449TS	SD200 841	1LE63224GC212AA1
200	1200	460	449T	SD100 IEEEE841	1LE24214CC512AA3	R449T	SD200 841	1LE63224TC212AA1
250	1200	460	B449T	SD100 IEEEE841	1LE24214EC612AA3	449T	SD200 841	1LE63224CC312AA1
250	1200	460	449TS	SD100 IEEEE841	1LE24214DC612AA3	449TS	SD200 841	1LE63224GC312AA1
250	1200	460	449T	SD100 IEEEE841	1LE24214CC612AA3	R449T	SD200 841	1LE63224TC312AA1
300	1200	460	S449SS	SD100 IEEEE841	1LE24214GC112AA3	L449TS	SD200 841	1LE63224HC112AA1
300	1200	460	S449LS	SD100 IEEEE841	1LE24214FC112AA3	RL449T	SD200 841	1LE63224UC112AA1
75	900	460	B444T	SD100 IEEEE841	1LE24214ED112AA3	444T	SD200 841	1LE63224BD112AA1
75	900	460	444TS	SD100 IEEEE841	1LE24214DD112AA3	444TS	SD200 841	1LE63224FD112AA1
75	900	460	444T	SD100 IEEEE841	1LE24214CD112AA3	R444T	SD200 841	1LE63224SD112AA1
100	900	460	B445T	SD100 IEEEE841	1LE24214ED212AA3	445T	SD200 841	1LE63224BD212AA1
100	900	460	445TS	SD100 IEEEE841	1LE24214DD212AA3	445TS	SD200 841	1LE63224FD212AA1
100	900	460	445T	SD100 IEEEE841	1LE24214CD212AA3	R445T	SD200 841	1LE63224SD212AA1
125	900	460	B447T	SD100 IEEEE841	1LE24214ED312AA3	447T	SD200 841	1LE63224CD112AA1
125	900	460	447TS	SD100 IEEEE841	1LE24214DD312AA3	447TS	SD200 841	1LE63224GD112AA1
125	900	460	447T	SD100 IEEEE841	1LE24214CD312AA3	R447T	SD200 841	1LE63224TD112AA1
150	900	460	B449T	SD100 IEEEE841	1LE24214ED512AA3	449T	SD200 841	1LE63224CD212AA1
150	900	460	449TS	SD100 IEEEE841	1LE24214DD512AA3	449TS	SD200 841	1LE63224GD212AA1
150	900	460	449T	SD100 IEEEE841	1LE24214CD512AA3	R449T	SD200 841	1LE63224TD212AA1
200	900	460	S449LS	SD100 IEEEE841	1LE24214FD112AA3	RL449T	SD200 841	1LE63224UD112AA1
250	900	460	S449LS	SD100 IEEEE841	1LE24214FD212AA3	RL449T	SD200 841	1LE63224UD212AA1
125	3600	575	444TS	SD100 IEEEE841	1LE24214DA113AA3	444TS	SD200 841	1LE63224FA113AA1
150	3600	575	445TS	SD100 IEEEE841	1LE24214DA213AA3	445TS	SD200 841	1LE63224FA213AA1
200	3600	575	447TS	SD100 IEEEE841	1LE24214DA313AA3	447TS	SD200 841	1LE63224GA113AA1
250	3600	575	449TS	SD100 IEEEE841	1LE24214DA513AA3	449TS	SD200 841	1LE63224GA213AA1
300	3600	575	449TS	SD100 IEEEE841	1LE24214DA613AA3	449TS	SD200 841	1LE63224GA313AA1
350	3600	575	S449SS	SD100 IEEEE841	1LE24214GA113AA3	L449TS	SD200 841	1LE63224HA113AA1
400	3600	575	S449SS	SD100 IEEEE841	1LE24214GA313AA3	L449TS	SD200 841	1LE63224HA213AA1
125	1800	575	B444T	SD100 IEEEE841	1LE24214EB113AA3	444T	SD200 841	1LE63224BB113AA1
125	1800	575	444TS	SD100 IEEEE841	1LE24214DB113AA3	444TS	SD200 841	1LE63224FB113AA1

			Phase Out - NEMA Motor SD100 IEEEE841			Next Generation NEMA SD200 841		
125	1800	575	444T	SD100 IEEEE841	1LE24214CB113AA3	R444T	SD200 841	1LE63224SB113AA1
150	1800	575	B445T	SD100 IEEEE841	1LE24214EB213AA3	445T	SD200 841	1LE63224BB213AA1
150	1800	575	445TS	SD100 IEEEE841	1LE24214DB213AA3	445TS	SD200 841	1LE63224FB213AA1
150	1800	575	445T	SD100 IEEEE841	1LE24214CB213AA3	R445T	SD200 841	1LE63224SB213AA1
200	1800	575	B447T	SD100 IEEEE841	1LE24214EB313AA3	447T	SD200 841	1LE63224CB113AA1
200	1800	575	447TS	SD100 IEEEE841	1LE24214DB313AA3	447TS	SD200 841	1LE63224GB113AA1
200	1800	575	447T	SD100 IEEEE841	1LE24214CB313AA3	R447T	SD200 841	1LE63224TB113AA1
250	1800	575	B449T	SD100 IEEEE841	1LE24214EB513AA3	449T	SD200 841	1LE63224CB213AA1
250	1800	575	449TS	SD100 IEEEE841	1LE24214DB513AA3	449TS	SD200 841	1LE63224GB213AA1
250	1800	575	449T	SD100 IEEEE841	1LE24214CB513AA3	R449T	SD200 841	1LE63224TB213AA1
300	1800	575	S449SS	SD100 IEEEE841	1LE24214GB113AA3	449TS	SD200 841	1LE63224GB313AA1

			Phase Out - NEMA Motor SD100			Next Generation NEMA SD200		
HP	RPM	Voltage	Frame	Type	Part Number	Frame	Type	Part Number
300	1800	575	S449LS	SD100 IEEEE841	1LE24214FB113AA3	R449T	SD200 841	1LE63224TB313AA1
350	1800	575	S449SS	SD100 IEEEE841	1LE24214GB213AA3	L449TS	SD200 841	1LE63224HB113AA1
350	1800	575	S449LS	SD100 IEEEE841	1LE24214FB213AA3	RL449T	SD200 841	1LE63224UB113AA1
400	1800	575	S449SS	SD100 IEEEE841	1LE24214GB313AA3	L449TS	SD200 841	1LE63224HB213AA1
400	1800	575	S449LS	SD100 IEEEE841	1LE24214FB313AA3	RL449T	SD200 841	1LE63224UB213AA1
100	1200	575	B444T	SD100 IEEEE841	1LE24214EC113AA3	444T	SD200 841	1LE63224BC113AA1
100	1200	575	444TS	SD100 IEEEE841	1LE24214DC113AA3	444TS	SD200 841	1LE63224FC113AA1
100	1200	575	444T	SD100 IEEEE841	1LE24214CC113AA3	R444T	SD200 841	1LE63224SC113AA1
125	1200	575	B445T	SD100 IEEEE841	1LE24214EC213AA3	445T	SD200 841	1LE63224BC213AA1
125	1200	575	445TS	SD100 IEEEE841	1LE24214DC213AA3	445TS	SD200 841	1LE63224FC213AA1
125	1200	575	445T	SD100 IEEEE841	1LE24214CC213AA3	R445T	SD200 841	1LE63224SC213AA1
150	1200	575	B447T	SD100 IEEEE841	1LE24214EC313AA3	447T	SD200 841	1LE63224CC113AA1
150	1200	575	447TS	SD100 IEEEE841	1LE24214DC313AA3	447TS	SD200 841	1LE63224GC113AA1
150	1200	575	447T	SD100 IEEEE841	1LE24214CC313AA3	R447T	SD200 841	1LE63224TC113AA1
200	1200	575	B449T	SD100 IEEEE841	1LE24214EC513AA3	449T	SD200 841	1LE63224CC213AA1
200	1200	575	449TS	SD100 IEEEE841	1LE24214DC513AA3	449TS	SD200 841	1LE63224GC213AA1
200	1200	575	449T	SD100 IEEEE841	1LE24214CC513AA3	R449T	SD200 841	1LE63224TC213AA1
250	1200	575	B449T	SD100 IEEEE841	1LE24214EC613AA3	449T	SD200 841	1LE63224CC313AA1

			Phase Out - NEMA Motor SD100			Next Generation NEMA SD200		
250	1200	575	449TS	SD100 IEEEE841	1LE24214DC613AA3	449TS	SD200 841	1LE63224GC313AA1
250	1200	575	449T	SD100 IEEEE841	1LE24214CC613AA3	R449T	SD200 841	1LE63224TC313AA1
300	1200	575	S449SS	SD100 IEEEE841	1LE24214GC113AA3	L449TS	SD200 841	1LE63224HC113AA1
300	1200	575	S449LS	SD100 IEEEE841	1LE24214FC113AA3	RL449T	SD200 841	1LE63224UC113AA1
75	900	575	B444T	SD100 IEEEE841	1LE24214ED113AA3	444T	SD200 841	1LE63224BD113AA1
75	900	575	444TS	SD100 IEEEE841	1LE24214DD113AA3	444TS	SD200 841	1LE63224FD113AA1
75	900	575	444T	SD100 IEEEE841	1LE24214CD113AA3	R444T	SD200 841	1LE63224SD113AA1
100	900	575	B445T	SD100 IEEEE841	1LE24214ED213AA3	445T	SD200 841	1LE63224BD213AA1
100	900	575	445TS	SD100 IEEEE841	1LE24214DD213AA3	445TS	SD200 841	1LE63224FD213AA1
100	900	575	445T	SD100 IEEEE841	1LE24214CD213AA3	R445T	SD200 841	1LE63224SD213AA1
125	900	575	B447T	SD100 IEEEE841	1LE24214ED313AA3	447T	SD200 841	1LE63224CD113AA1
125	900	575	447TS	SD100 IEEEE841	1LE24214DD313AA3	447TS	SD200 841	1LE63224GD113AA1
125	900	575	447T	SD100 IEEEE841	1LE24214CD313AA3	R447T	SD200 841	1LE63224TD113AA1
150	900	575	B449T	SD100 IEEEE841	1LE24214ED513AA3	449T	SD200 841	1LE63224CD213AA1
150	900	575	449TS	SD100 IEEEE841	1LE24214DD513AA3	449TS	SD200 841	1LE63224GD213AA1
150	900	575	449T	SD100 IEEEE841	1LE24214CD513AA3	R449T	SD200 841	1LE63224TD213AA1
200	900	575	S449LS	SD100 IEEEE841	1LE24214FD113AA3	RL449T	SD200 841	1LE63224UD113AA1
250	900	575	S449LS	SD100 IEEEE841	1LE24214FD213AA3	RL449T	SD200 841	1LE63224UD213AA1

—
ABB MOTORS AND MECHANICAL INC

5711 RS Boreham, Jr Street
Fort Smith, AR 72901
1-800-456-1876

[NEW.ABB.COM/MOTORS-GENERATORS/NEMA-LOW-VOLTAGE-AC-MOTORS](https://new.abb.com/motors-generators/nema-low-voltage-ac-motors)

© Copyright 2023 ABB. All rights reserved.
Specifications subject to change without notice.