

811SP Series

PRODUCT BROCHURE



Where Innovation Flows

Centrifugal Pumps



Griswold® Centrifugal Pumps

Griswold® is a premier manufacturer of centrifugal pumps and baseplate systems. With engineering expertise, lean manufacturing, testing capabilities and exceptional customer support, Griswold meets its customers' most demanding application requirements, all while minimizing project costs.

811SP Series Self-Priming Centrifugal Pumps

The 811SP Series are self-priming centrifugal pumps available in a wide range of sizes, capacities and materials to fit virtually any process-fluid application. Specially engineered to be part-for-part interchangeable with the Griswold 811 ANSI Series and competitor pumps in equivalent sizes, the 811SP Series is easily retrofittable in thousands of installations worldwide.



CHEMICAL TRANSFER



PETROCHEMICAL



AUTOMOTIVE FUELING



INDUSTRIAL SUMP



DEWATERING



Features and Benefits

- Component interchangeability with Griswold 811 ANSI Series ASME B73.1 pumps
- Designed to meet the requirement of ASME B73.1
- Extra-large capacity, epoxy-coated oil sump
- Quick priming time and easy drainage
- Dynamically balanced impellers increase pump life cycle
- Casing retains priming fluid during siphon conditions
- Heavy-duty power frames
- Magnetic power frame drain plug
- Fully open impellers with rear-adjustment capability
- Wide variety of mechanical seal options
- High-quality, genuine, certified parts
- Part-for-part interchangeability with select competitor models
- Easy retrofit from Griswold 811 ANSI Series pumps and select competitor models
- Available with steel, stainless steel, or composite baseplates
- Performance validated in a test lab certified per Hydraulic Institute (HI) 14.6
- Material certifications per ASTM
- Easy service of one-piece casing with access holes

Applications

- Industrial Sump
- Mine Dewatering
- Chemical Transfer
- Bilge Water Removal
- Coal Pile Drainage
- Tank Car Unloading
- Petroleum Transfer

Genuine Parts and Part-for-Part Interchangeability

When meeting your production quota is compromised, waiting for repairs can mean significant losses in revenue (which is a factor in true cost of ownership). The Griswold 811SP Series and an extensive inventory of parts are interchangeable with hundreds of thousands of ANSI pumps currently in use. With stocking distributors from coast-to-coast and throughout the world, you can be up and running before you even get a response call from the competition!

Engineered for Flexibility & Durability



TECHNOLOGY: SELF-PRIMING CENTRIFUGAL PUMPS

811SP Series

The 811SP Series is available in 8 different sizes and utilizes a CD4MCuN case as standard, making it ideal for virtually any process-fluid application. It is designed and engineered to provide flexibility and interchangeability by sharing all back-end components with Griswold's 811 ANSI Series line of ASME (ANSI) B73.1 centrifugal pumps.

Technical Specifications

- Max. flow: 1,300 gpm (295 m³/hr)
- Max. head: 380 ft (115 m)
- Max. temperature: 500°F (260°C)
- Casing pressure ratings meeting pressure ratings of Class 150 flanges
- Effective static lifts to 25 ft (7.5 m)

CERTIFICATIONS & ASSOCIATIONS:



Pump Design Features

- 1 Ductile Iron Frame Adapters**
Ductile-iron construction provides strength and safety. Precision machined to accurately align the liquid end to the power end. Large openings simplify installation and maintenance. Includes jacking bolts to facilitate disassembly.
- 2 Labyrinth Seals Standard**
INPRO® oil seals keep outside contaminants from lubrication media, significantly extending bearing life. Standard in bronze. Carbon-filled PTFE and magnetic face seals optional.
- 3 Mounting Frame Flange**
Machined to accommodate C-face motor adapters.
- 4 Extra-Large Capacity Powder-Coated Oil Sump**
Maximized oil capacity delivers improved heat transfer and oil temperature, greatly extending bearing life. Designed to accommodate optional fin coolers for high-temperature applications. Impenetrable fusion-bonded epoxy coating on interior surface extends quality, cleanliness and longevity of the lubricating oil.
- 5 External Clearance Adjustment**
Designed for maintaining original flow, pressure and efficiency, minimizing energy consumption and repairs, and extending mean time between repairs (MTBR).

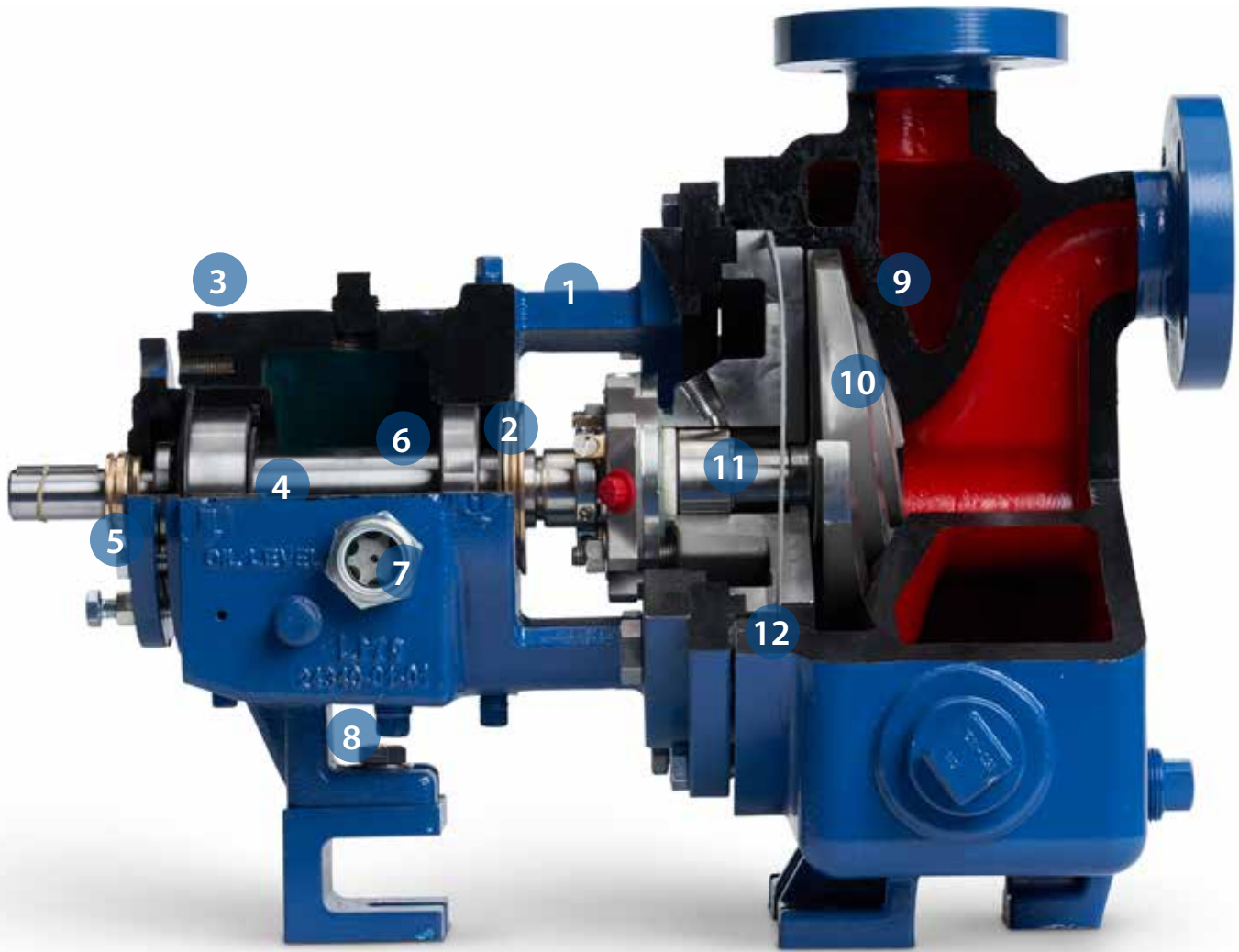

6 Heavy-Duty Shaft and Bearings

Engineered to minimize vibration and shaft deflection, less than 0.002 inch per ASME (ANSI) B73.1, optimizing pump life. Sleeved and solid shaft available in a variety of materials. Bearings sized for 10-year life expectancy under tough operating conditions.



7 Oversized Sight Glass

One-inch bullseye reflective sight glass facilitates monitoring oil level and condition, critical to bearing life. Bottle oiler optional.

8 Magnetic Drain Plug

Collects damaging metallic contaminants away from the bearings.

9 Self-Priming Casing

- Integral priming chamber one-piece casing design
- Top centerline self-venting discharge
- Back pull-out to simplify maintenance
- Rigid casing feet prevent pipe-load misalignment and promote seal/casing life

- Provisions for discharge and suction flange taps for gauge and seal flush connections
- Class 150 FF flanges with serrated finish are standard for positive sealing, Class 150 RF / 300 FF/RF available
- Casing drain is standard for simplified maintenance

10 Fully Open Impeller

With double the wear area of enclosed models, the 811SP Series impeller offers superior handling of solids, corrosives and abrasives. Back pump-out vanes reduce hydraulic loads and seal chamber pressure.



11 Sealing Flexibility

Wide range of sealing options coupled with seal chambers and stuffing boxes selected for service condition to improve lubrication and heat dissipation of seal faces, maximizing pump uptime.

12 Contained Casing Gasket

Provides positive sealing at casing joint to prevent “blow out” of liquids and to facilitate disassembly.



811SP Series Options and Accessories

Seal Chambers & Sealing Flexibility:

Our quality seal chambers are engineered to provide optimum seal environment for heat dissipation, solids, entrapped air and vapor. Oversized seal chambers increase radial clearance between the mechanical seal and seal chamber, as well as provide better circulation of liquid to and from the seal faces, preventing failure of the shaft seal. A variety of flush plans are available for additional lubrication and cooling of the seal faces.

	Standard Bore	Large Bore	Tapered Bore
			
Services	Services utilizing packing or mechanical seals. For mild fluid at ambient temperatures.	Most services including those with solids greater than 10%. Increased radial clearance between seal and chamber for improved liquid circulation, lubrication and cooling.	Services up to 10% solids or those containing entrained air or vapors. For lower seal face temperatures, self venting and draining. Circulates solids and vapors away from seal faces.
Sealing Flexibility			
Packing	Most Services	Not Available	Not Available
Single Seal/No Flush	Not Recommended	Not Recommended	Services with Solids up to 10%
Single Seal/With Flush	Mild, Clear Fluids	Most Services Including Solids above 10%	All Services with Solids up to 10%
Conventional Double Seal with Seal Plan	Zero Leakage Applications	Zero Leakage Applications	Not Available
Cartridge Double Seal with Seal Plan	Zero Leakage Applications	Zero Leakage Applications	Zero Leakage Applications

Seals To Fit Any Application:

CARTRIDGE SEALS, COMPONENT SEALS & CONVENTIONAL PACKING

With Griswold's broad selection of seals, you can accommodate most any fluid and temperature for demanding chemical, petroleum, pharmaceutical and general industry applications. Our engineers can recommend the best seal to maximize your application and system life—including cartridge or component, single or double, inside or outside, balance or unbalanced seals or conventional packing.



Single Cartridge Seal



Double Cartridge Seal



Double Gas Barrier Seal



Single Inside Seal



Conventional Double Seal



Extensive Options

Griswold offers a broad range of options and upgrades to tailor the 811SP Series handling and performance to meet virtually any fluid-processing application. The Griswold engineering staff can assist you in configuring pump size, material and components to best suit your specific plant and processing requirements.



Seal-Flush Plans

ASME (ANSI) B73.1 seal-flush and cooling plans are offered to control emission levels, improve lubrication and cooling of the seal faces, and reduce downtime. Ask for assistance in selecting the best plan.

Lubrication Options

811SP Series power ends accommodate all lubrication systems, including flood oil, oil mist and grease lubrication. The power ends are pre-drilled for all lubrication methods and can be easily converted in the field without modification.



Accessories

Griswold offers a variety of accessories to adapt to application requirements

- *Baseplate Mounting Systems* to reduce stress and vibration
- *Heavy-Duty C-Face Motor Adapter* to guarantee alignment
- *Watchdog Oiler* for constant oil levels
- *Bearing Frame Finned Cooler* to directly cool oil to lower bearing temperature

811SP Series Performance & Specifications

3600 / 1800 RPM Performance Coverage

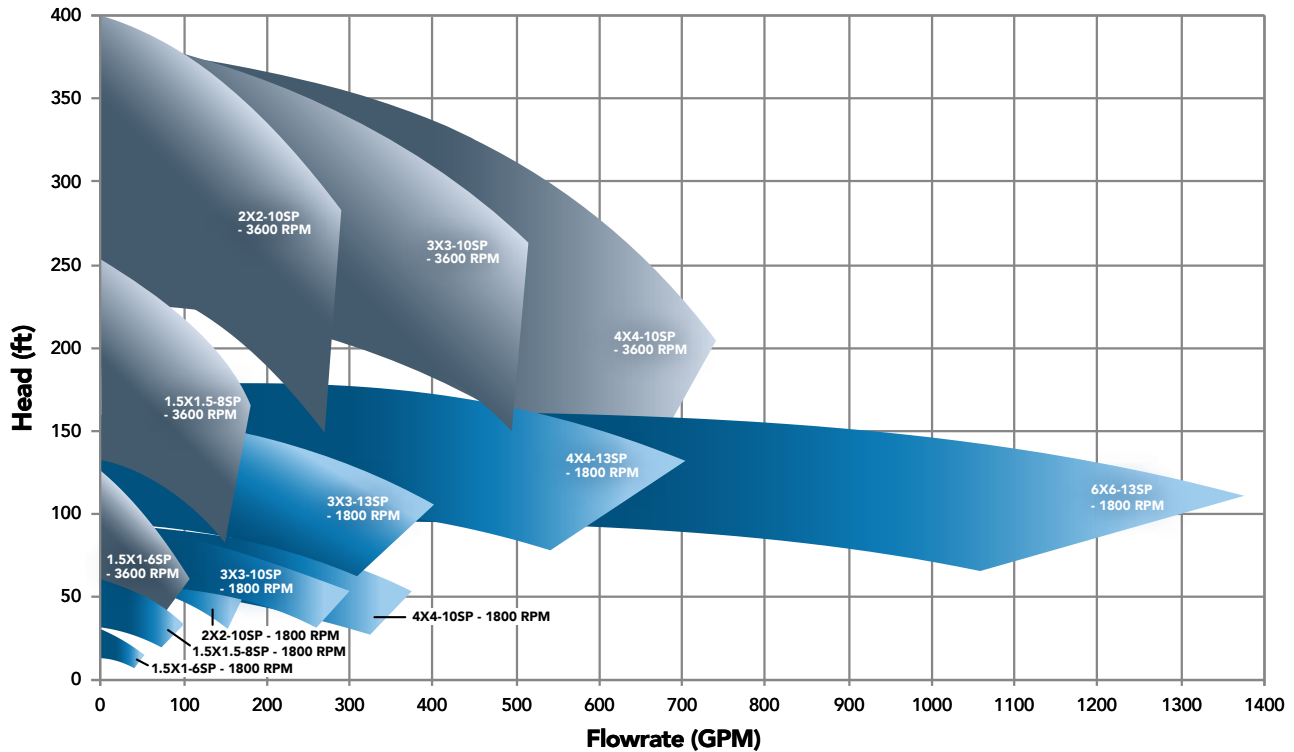

Pressure and Temperature Capability

Maximum Working Pressure Limits
Class 150 and Class 300 Flanges

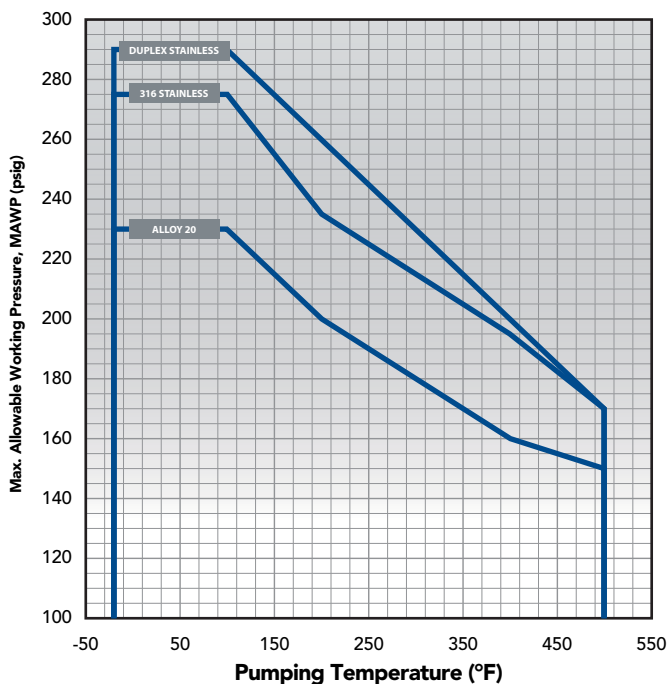

B.H.P. Limits

R.P.M.	MODEL		
	811SP Small Frame	811SP Medium Frame	811SP Large Frame
3560	40.0	122.0	200.0
2900	32.6	99.4	162.9
1780	20.0	61.0	100.0
1450	16.3	49.7	81.5
1180	13.3	40.4	66.3
880	9.9	30.2	49.4

Material/Casting Specs

DASH	MATERIAL	CASTING SPECIFICATIONS
91	316SS	ASTM A351 Grade CF8M
20	Alloy 20	ASTM A351 Grade CN7M
X4	Duplex	ASTM A995 Grade 1B (CD4MCuN)

811SP Series Parts, Materials, and Interchangeability

Parts List Key

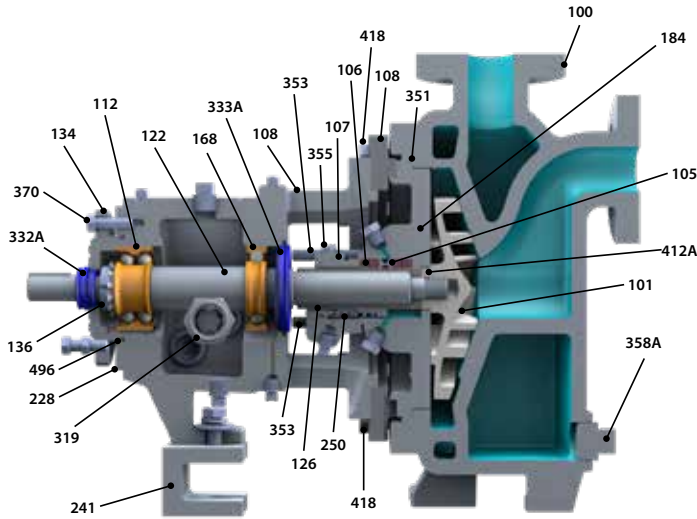

Parts and Material Composition

ITEM NO.	REQ'D PER PUMP	PART NAME	ALL CD4MCuN	ALL 316SS	ALL ALLOY 20
100	1	Casing	CD4MCuN	316 SS	Alloy 20
101	1	Impeller	CD4MCuN	316 SS	Alloy 20
105	1	Lantern Ring	Glass-Filled TFE		
106	1	Packing	TFE	SIL C-8201 Acid Rest.	TFE
107	1	Packing Gland	Alloy 20	316 SS	Alloy 20
108	1	Frame Adapter	Ductile Iron		
112	1	Outboard (Thrust) Bearing	Double-Row Angular Contact*		
122	1	Shaft – Less Sleeve (Optional – Not Shown)	Alloy 20	316 SS	Alloy 20
122	1	Shaft – With Sleeve	SAE4140		
126	1	Shaft Sleeve	Alloy 20	316 SS	Alloy 20
134	1	Bearing Housing	Cast Iron		
136	1	Lock Nut / Lock Washer	Steel		
168	1	Inboard (Radial) Bearing	Single-Row Deep Groove		
184	1	Stuffing Box	CD4MCuN	316 SS	Alloy 20
228	1	Frame	Cast Iron		
240	1	Frame Foot Spacer** (Not Shown)	Steel		
241	1	Frame Foot	Cast Iron		
250	1	Mechanical Seal Gland	Alloy 20	316 SS	Alloy 20
319	1	Sight-Oil Gauge	Cad. Plated		
332A	1	Labyrinth Oil Seal (Outboard)	Bronze (Optional Carbon-Filled PTFE)		
333A	1	Labyrinth Oil Seal (Inboard)	Bronze (Optional Carbon-Filled PTFE)		
351	1	Casing Gasket	Aramid Fiber with EPDM Rubber		
353	4	Gland Stud	316SS		
355	4	Gland Nut	304SS		
358A	1	Casing Drain Plug	316 SS	316 SS	Alloy 20
360	1	Gasket, Frame-to-Adapter (Not Shown)	Vellumoid		
370	6	Bearing Housing Hex Bolt	Steel		
412A	1	Impeller O-Ring	Glass-Filled TFE		
418	3	Casing Jacket Screw	Steel		
469B	2	Dowel Pin (Not Shown)	Steel		
496	1	Bearing Housing O-Ring	Buna Rubber		

*811SP Large Frame features Duplex Angular Contact. Additional materials available on request.
 **Frame Foot spacer only used on 6x6-13

Construction Details

GRISWOLD 811SP MODEL		811SP SMALL FRAME	811SP MEDIUM FRAME	811SP LARGE FRAME
Corrosion Allowance @ Max.		0.125		
Max. Allowable Working Pressure (MAWP)		See Pressure and Temperature Capability Chart (pg. 8)		
Hydrostatic Test Pressure		150% MAWP at 100°F (38°C)		
Max. Liquid Temp.		350°F (177°C) without Cooling / 500°F (260°C) with Cooling		
Shaft Diameter	At Coupling (in.)	0.875	1.125	1.875
	Sleeve Dia. Under Seal (in.)	1.375	1.75	2.125
	Sleeve Dia. Under Seal (in.)	0.75	1	1.25
	Under Sleeve (in.)	1.125	1.5	1.875
	Overhang (in.)	6.125	8.375	8.375
Bearings	Radial	SKF 6207	SKF 6309	SKF 6311
	Thrust	SKF 5306 A/C3	SKF 5309 A/C3	SKF 7310 BECBM
	Bearing Span	4.125	6.75	6.875

GRISWOLD 811SP MODEL		811SP SMALL FRAME	811SP MEDIUM FRAME	811SP LARGE FRAME
Mechanical Seal Size (in.)		1.375	1.75	2.125
Stuffing Box Standard Bore	I.D. (in.)	2.00	2.5	2.875
	Depth (in.)	2.125	2.625	
	Distance End of Box to Nearest Obstruction	2.5	2.813	
Stuffing Box Large Bore	I.D. (in.)	2.875	3.50	3.875
	Depth (in.)	2.125	2.125	
	Distance End of Box to Nearest Obstruction	2.50	2.813	
Lantern Ring Width (in.)		0.438	0.625	

Component Interchangeability

Griswold 811SP Series pumps are designed to be easy to maintain and repair. Many of the pump components can be interchanged between the models in order to maximize interchangeability within the portfolio to help simplify inventory and reduce costs.

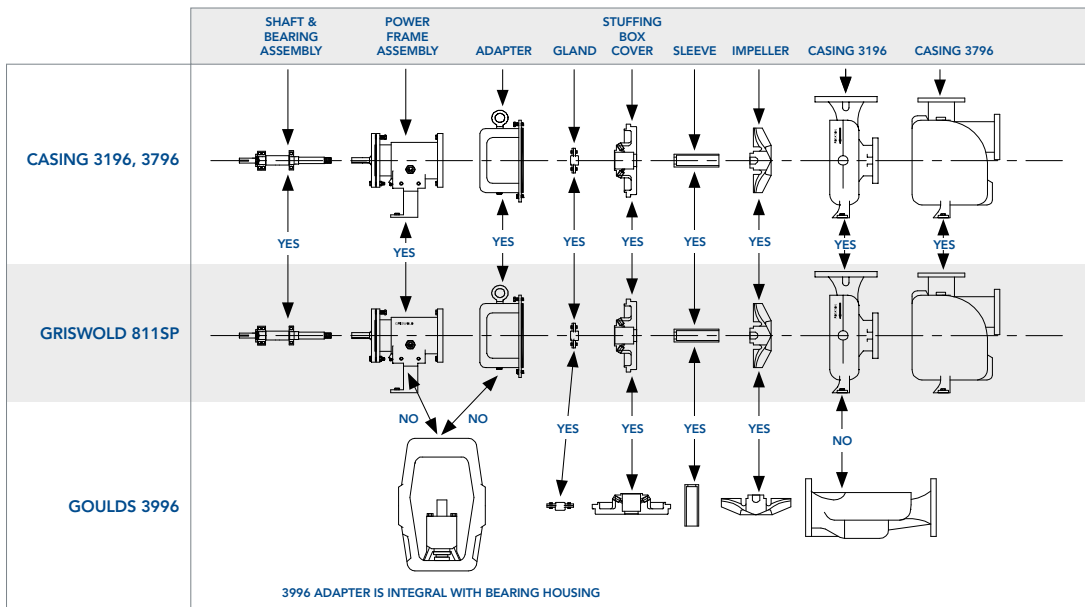
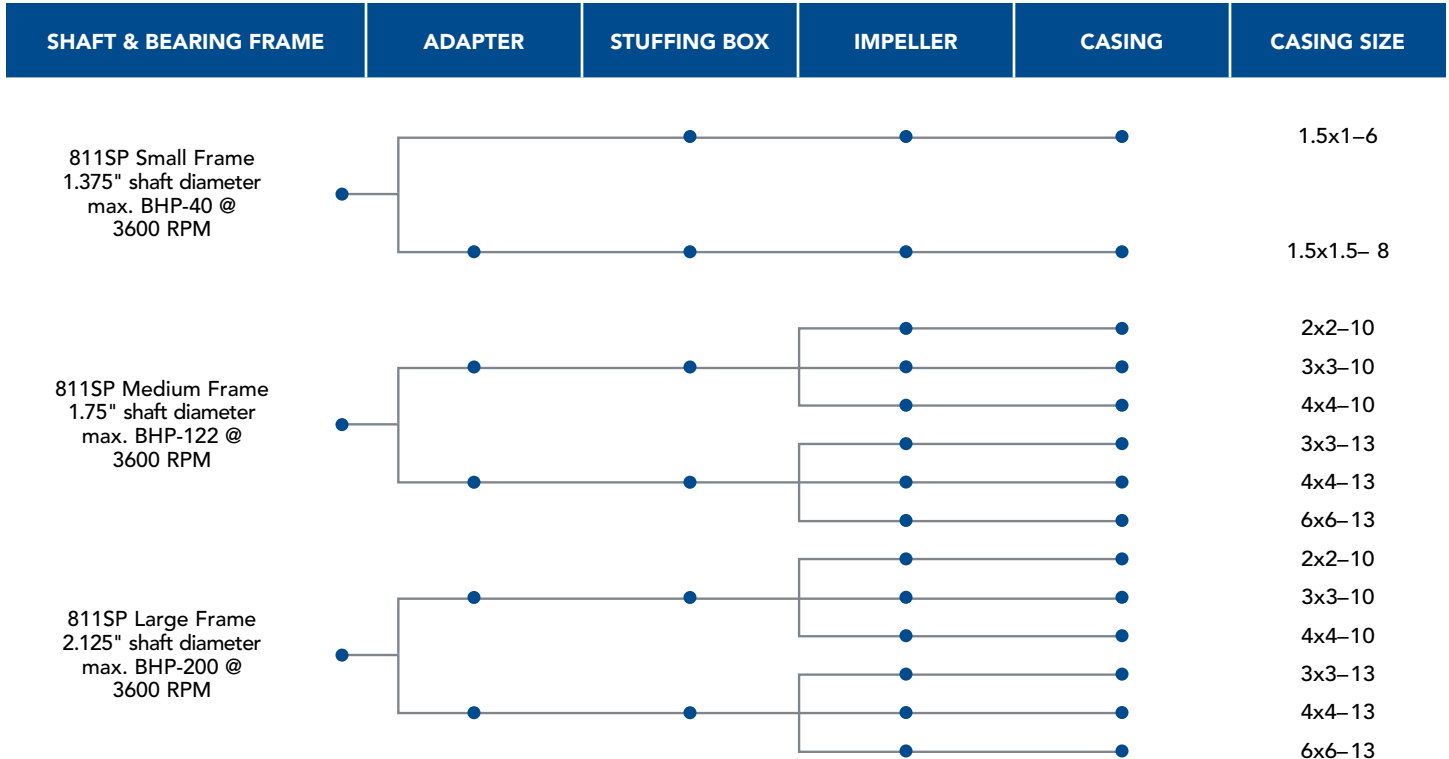

Griswold 811SP Series Competitor Part-for-Part Interchangeability

Griswold 811SP Series Pumps and Parts are interchangeable with Goulds Pumps 3196 and other centrifugal pump models. For more information, visit our website to review our interchangeability guide.

*Goulds Pumps is a registered trademark of ITT Corporation

811SP Series Dimensions

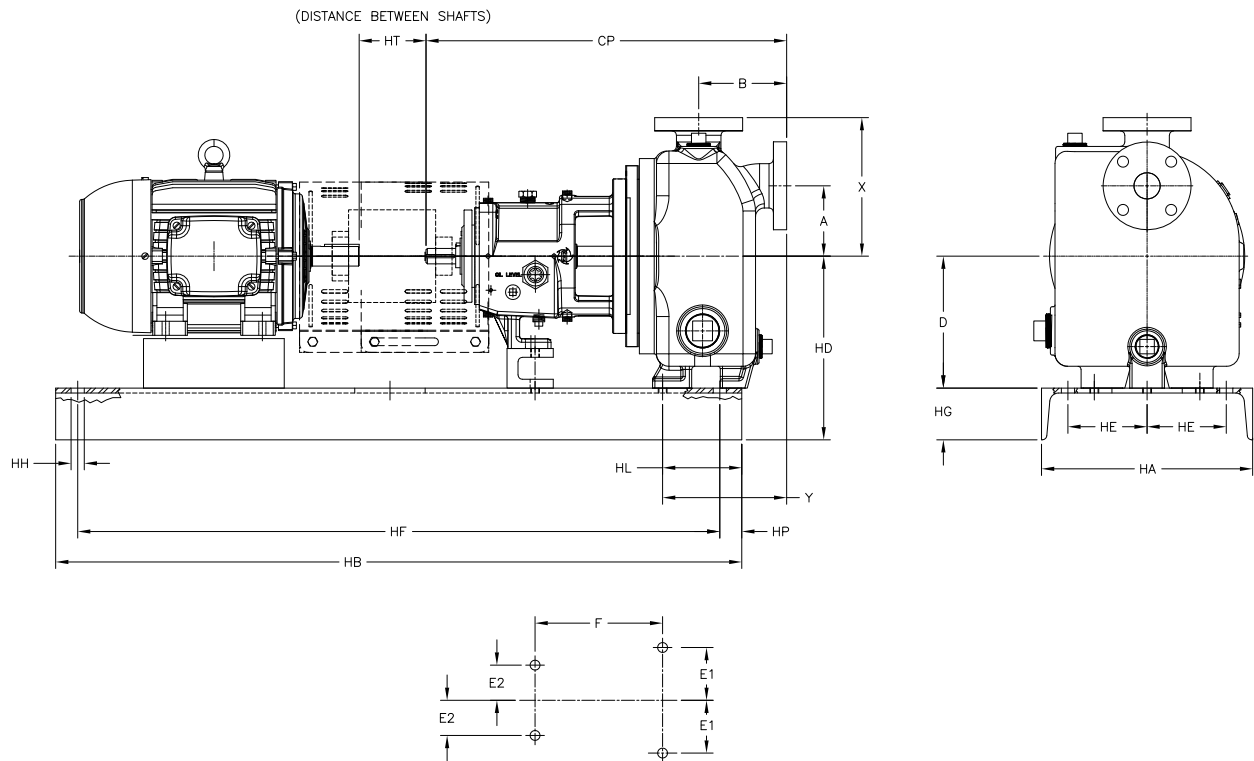

Small Pump End and Baseplate

PUMP-END DIMENSIONS (INCHES)												
	Pump Size	Discharge	Suction	A	B	D	X	Y	CP	E1	E2	F
SMALL	1.5x1-6	1	1.5	4	5	7.5	7.25	7	20.5	3	0	7.25
	1.5x1.5-8	1.5	1.5	4	5	7.5	7.88	7	20.5	3	0	7.25

BASEPLATE DIMENSIONS (INCHES)												
Max NEMA Frame	Baseplate Number	HA Max	HB	HT Min	HD Max	HE	HF	HG Max	HH	HL	HP	
184T	139	15	39	3.5	9	4.5	36.5	3.75	0.75	4.5	1.25	
256T	148	18	48	3.5	10.5	6	45.5	4.13	0.75	4.5	1.25	
326TS	153	21	53	3.5	12.88	7.5	50.5	4.75	0.75	4.5	1.25	

Medium and Large Pump End and Baseplate

PUMP-END DIMENSIONS (INCHES)												
	Pump Size	Discharge	Suction	A	B	D	X	Y	CP	E1	E2	F
MEDIUM OR LARGE	2x2-10	2	2	6	6.5	10	10	8.67	28.25	4.88	3.63	12.50
	3x3-10	3	3	6	6.75	10	10	10.00	29.38	4.88	3.63	12.50
	4x4-10	4	4	6	9.19	10	10	13.00	32.57	4.88	3.63	12.50
	3x3-13	3	3	6	6.75	10	11.5	10.00	29.38	4.88	3.63	12.50
	4x4-13	4	4	6	9.19	10	11.5	12.15	31.57	4.88	3.63	12.50
	6x6-13	6	6	6	7	7.50	12	15	15.83	35.25	4.88	3.63

BASEPLATE DIMENSIONS (INCHES)												
Max NEMA Frame	Baseplate Number	HA Max	HB	HT Min	HD Max (IFD=10.00)	HD Max (IFD=12.00)	HE	HF	HG Max	HH	HL	HP
184T	245	15	45	3.5	13.75	15.75	4.5	42.5	3.75	0.75	4.5	1.25
215T	252	18	52	3.5	14.13	16.13	6	49.5	4.13	0.75	4.5	1.25
286TS	258	21	58	3.5	14.75	16.75	7.5	55.5	4.75	1	4.5	1.25
365TS	264	21	64	3.5	14.75	16.75	7.5	61.5	4.75	1	4.5	1.25
405TS	268	26	68	3.5	14.88	16.88	9.5	65.5	4.75	1	4.5	1.25



PSG
22069 Van Buren Street
Grand Terrace
CA, 92313-5651
USA
P: +1 (909) 512-1262
F: +1 (909) 783-3440
griswoldpump.com



Where Innovation Flows

GRS-10100-C-01

Authorized PSG® Partner:

Copyright 2021 PSG®, a Dover company